



- (51) International Patent Classification:
B01D 35/02 (2006.01) *B01D 35/30* (2006.01)
- (21) International Application Number:
PCT/US2018/018696
- (22) International Filing Date:
20 February 2018 (20.02.2018)
- (25) Filing Language: English
- (26) Publication Language: English
- (30) Priority Data:
62/472,170 16 March 2017 (16.03.2017) US
- (71) Applicant: CUMMINS FILTRATION IP, INC.
[US/US]; 500 Jackson Street, Columbus, Indiana 47201 (US).
- (72) Inventors: KNIGHT, Jessie A.; 848 Peace Lane, Oregon, Wisconsin 53575 (US). SCHWARTZ, Scott W.; 4644 Pierceville Road, Cottage Grove, Wisconsin 53527 (US). LOKEN, Gregory K.; 1901 Meadow Dr., Stoughton, Wisconsin 53589 (US). MANKE, Scott G.; 1318 Gray Hawk Way, Sun Prairie, Wisconsin 53590 (US).
- (74) Agent: BROWN, Marshall J. et al.; Foley & Lardner LLP, 3000 K St. NW., Washington, District of Columbia 20007 (US).
- (81) Designated States (unless otherwise indicated, for every kind of national protection available): AE, AG, AL, AM, AO, AT, AU, AZ, BA, BB, BG, BH, BN, BR, BW, BY, BZ, CA, CH, CL, CN, CO, CR, CU, CZ, DE, DJ, DK, DM, DO, DZ, EC, EE, EG, ES, FI, GB, GD, GE, GH, GM, GT, HN, HR, HU, ID, IL, IN, IR, IS, JO, JP, KE, KG, KH, KN, KP, KR, KW, KZ, LA, LC, LK, LR, LS, LU, LY, MA, MD, ME, MG, MK, MN, MW, MX, MY, MZ, NA, NG, NI, NO, NZ, OM, PA, PE, PG, PH, PL, PT, QA, RO, RS, RU, RW, SA, SC, SD, SE, SG, SK, SL, SM, ST, SV, SY, TH, TJ, TM, TN, TR, TT, TZ, UA, UG, US, UZ, VC, VN, ZA, ZM, ZW.
- (84) Designated States (unless otherwise indicated, for every kind of regional protection available): ARIPO (BW, GH, GM, KE, LR, LS, MW, MZ, NA, RW, SD, SL, ST, SZ, TZ, UG, ZM, ZW), Eurasian (AM, AZ, BY, KG, KZ, RU, TJ, TM), European (AL, AT, BE, BG, CH, CY, CZ, DE, DK, EE, ES, FI, FR, GB, GR, HR, HU, IE, IS, IT, LT, LU, LV, MC, MK, MT, NL, NO, PL, PT, RO, RS, SE, SI, SK, SM, TR), OAPI (BF, BJ, CF, CG, CI, CM, GA, GN, GQ, GW, KM, ML, MR, NE, SN, TD, TG).

(54) Title: FILTRATION SEALING SYSTEM

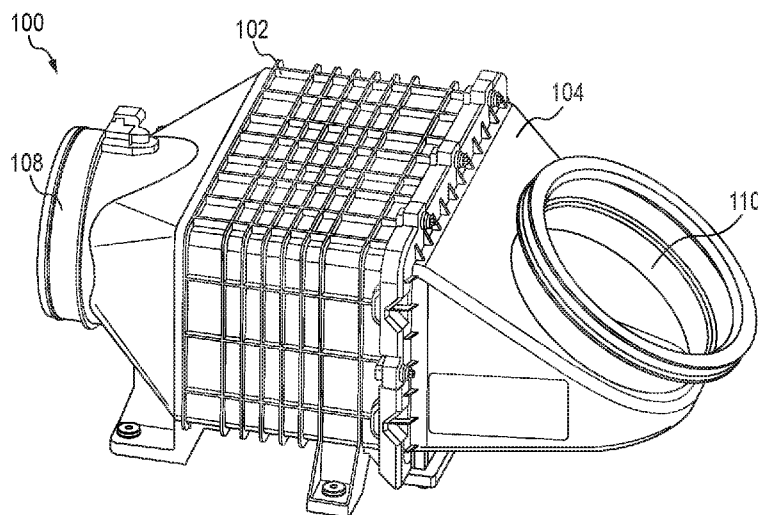

FIG. 1

(57) Abstract: A filtration system comprising a housing defining a central compartment, an outlet and a housing sealing surface having a first non-planar surface. A cover is removably coupled to the housing. The cover defines an inlet and comprises a cover sealing surface having a second non-planar surface. The filtration system also includes a filter element comprising a filter media and a seal member. The filter element is removably received in the central compartment. The seal member comprising a complimentary non-planar sealing surface that matches the first non-planar surface and the second non-planar surface such that the seal member axially pinched between the housing and the cover by the housing sealing surface and the cover sealing surface to form a first seal between the seal member and the housing and a second seal between the seal member and the cover..



Published:

— *with international search report (Art. 21(3))*

FILTRATION SEALING SYSTEM

CROSS-REFERENCE TO RELATED APPLICATIONS

[0001] The present application claims priority to and benefit of U.S. Provisional Patent Application No. 62/472,170, filed March 16, 2017 and entitled “Filtration Sealing System,” the entire disclosure of which is incorporated herein by reference.

TECHNICAL FIELD

[0002] The present application relates to filtration systems.

BACKGROUND

[0003] Internal combustion engines generally combust a mixture of fuel (e.g., gasoline, diesel, natural gas, etc.) and air. Prior to entering the engine, the intake air is typically passed through a filtration system to remove contaminants (e.g., dust, water, oil, etc.) from the intake air. The filtration system includes a filter element having filter media. As the air passes through the filter media of the filter element, the filter media removes at least a portion of the contaminants in the air thereby preventing unwanted contaminants from entering the internal combustion engine.

[0004] The filter elements often include a seal member that is compressed against a component of the filtration system housing, between two components of the filtration system, or a combination thereof. The seal member forms a seal between the filtration system housing and the filter element thereby eliminating the ability of fluid to bypass the filter element (e.g., for air to bypass an air filter element). If an improper filter element (i.e., a non-authorized or non-genuine filter element) is installed in a filtration system, the seal member of the filter element may not form a proper seal, and fluid may bypass the filter element causing damage to downstream components.

SUMMARY

[0005] Various example embodiments relate to filter elements and filtration systems having matching axially contoured (i.e., non-planar) seal members and sealing surfaces. One example embodiment relates to a filtration system. The filtration system comprises a housing defining a central compartment and an outlet and comprising a housing sealing surface having a first non-planar surface. The filtration system further comprises a cover removably coupled to the housing, the cover defining an inlet and comprising a cover sealing surface having a second non-planar surface. The filtration system comprises a filter element comprising filter media and a seal member. The filter element is removably received in the central compartment. The seal member comprises a complimentary non-planar sealing surface that matches the first non-planar surface and the second non-planar surface. The seal member is axially pinched between the housing and the cover by the housing sealing surface and the cover sealing surface to form a first seal between the seal member and the housing and a second seal between the seal member and the cover.

[0006] Another example embodiment relates to a filter element removably receivable within a central compartment of a housing. The filter element comprises a filter media and a seal member. The seal member comprises a complimentary non-planar sealing surface that matches (a) a first non-planar surface of a housing sealing surface of the housing and (b) a second non-planar surface of a cover sealing surface of a cover that is removably coupleable to the housing. When the filter element, the housing, and the cover are in a fully assembled state, the seal member is axially pinched between the housing and the cover by the housing sealing surface and the cover sealing surface to form a first seal between the seal member and the housing and a second seal between the seal member and the cover.

[0007] Still another example embodiment relates to a method comprising providing a housing defining a central compartment and an outlet. The housing comprises a housing sealing surface having a first non-planar surface. A cover defining an inlet and comprising a cover sealing surface having a second non-planar surface is provided. A filter media of a filter element is positioned in the central compartment. The filter element also comprises a seal member. The seal member comprises a complimentary non-planar sealing surface that matches the first non-

planar surface and the second non-planar surface. The cover is coupled to the housing such that the seal member is axially pinched between the housing and the cover by the housing sealing surface and the cover sealing surface, so as to form a first seal between the seal member and the housing and a second seal between the seal member and the cover.

[0008] These and other features, together with the organization and manner of operation thereof, will become apparent from the following detailed description when taken in conjunction with the accompanying drawings, wherein like elements have like numerals throughout the several drawings described below.

BRIEF DESCRIPTION OF THE FIGURES

[0009] FIG. 1 shows a perspective view of a filtration system according to an example embodiment.

[0010] FIG. 2 shows a perspective view of the filtration system of FIG. 1 with the cover partially removed.

[0011] FIG. 3 shows an exploded view of the filtration system of FIG. 1.

[0012] FIG. 4 shows a perspective view of a filter element of the filtration system of FIG. 1.

[0013] FIG. 5 shows a perspective view of the filter element of FIG. 4 being installed in the filtration system of FIG. 1.

[0014] FIG. 6 shows a perspective view of the filter element of FIG. 4 fully seated in the filtration system of FIG. 1.

[0015] FIG. 7 shows a cross-sectional view of a planar seal area of the filtration system of FIG. 1.

[0016] FIG. 8 shows a cross-sectional view of a contoured (i.e., non-planar) seal area of the filtration system of FIG. 1.

[0017] FIG. 9 shows a cross-sectional view of the sealing area of the filtration system of FIG. 1.

[0018] FIG. 10 shows an exploded view of a filtration systems, according to another embodiment.

[0019] FIG. 11 shows a cross-sectional view of the sealing area of the filtration system of FIG. 10 with a cover of the filtration system removed from a housing of the filtration system.

[0020] FIG. 12 shows a perspective view of a filter element of the filtration system of FIG. 10.

[0021] FIG. 13 is a schematic flow diagram of an example method for providing a filtration system.

DETAILED DESCRIPTION

[0022] Referring to the figures generally, a filtration system having both planar and non-planar portions (i.e., non-planar, arched, contoured, comprised of multiple intersecting planar sub-portions, etc.) sealing areas between the filtration system housing and the installed filter element is described.

[0023] Referring to FIGS. 1 through 3, various perspective views of a filtration system 100 are shown according to an example embodiment. FIG. 1 shows the filtration system 100 in a fully assembled state. FIG. 2 shows the filtration system 100 in a partially disassembled state. FIG. 3 shows the filtration system 100 in a fully disassembled state. The filtration system 100 generally includes a housing 102, a cover 104 removably coupled to the housing 102, and a filter element 106 installed in the filtration system 100. The housing 102 includes an outlet 108. The cover 104 includes an inlet 110. The housing 102 generally defines a central compartment configured to receive the filter element 106. When the filtration system 100 is fully assembled (e.g., as shown in FIG. 1), fluid to be filtered (e.g., air) flows into the inlet 110, through the filter element 106, and out the outlet 108. The outlet 108 may be in fluid communication with a downstream component, such as an internal combustion engine.

[0024] A perspective view of the filter element 106 is shown in FIG. 4. The filter element 106 comprises filter media 112 and a seal member 114. The filter media 112 may be, for example, pleated filter media arranged in a panel or pleat block. Although shown as being generally rectangular in shape, the filter element 106 may be arranged in other shapes, such as a cylinder, an oval, or the like.

[0025] The seal member 114 is comprised of and attached to the filter media 112 with an adhesive, such as polyurethane. In some arrangements, the seal member 114 includes an embedded frame member or stiffening member to help maintain the shape of the seal member 114. In further or additional arrangements, the seal member 114 is connected to the filter media 112 through an intermediate frame member, such as a circumferential support. As described in further detail below, the seal member 114 generally includes both planar portions and non-planar portions (i.e., curved, arched, contoured, portions comprised of multiple intersecting sub-portions, etc.) portions configured to interact with matching planar and curved surfaces of the housing 102 and the cover 104. The seal member 114 is an axial seal member configured to form a seal with the housing 102 and the cover 104 such that fluid being filtered through the filtration system 100 cannot bypass the filter element 106.

[0026] FIGS. 5 and 6 show the filter element 106 being installed (i.e., seated) into the housing 102. FIGS. 7, 8, and 9 show the filter element 106 fully installed in the filtration system 100 such that the seal member 114 is compressed between the housing 102 and the cover 104. As shown in FIG. 5, the filter media 112 of the filter element 106 is inserted into the central compartment of the housing 102. The housing 102 includes a housing sealing surface 120. The housing sealing surface 120 includes a planar portion 122 and non-planar portions 124 on two of four sides of the housing sealing surface 120. In some arrangements, the non-planar portions 124 are comprised of multiple planar sub-portions arranged at different angles relative to (e.g., to form a vertex, to form a plateau, etc.). In other arrangements, the non-planar portions 124 are comprised of a curved portion. In some arrangements, the curved portions are arched in shape. In such arrangements, the curved portions 124 may be concave recessed slits. The planar portion 122 and the non-planar portions 124 are sized and shaped to be complimentary to a corresponding planar portion 126 and non-planar portions 128 of the

seal member 114. The non-planar portions 124 and 128 help align the filter element 106 in the housing 102 during installation. Since the filter element 106 and the housing 102 have complimentary sealing surfaces, the filter element 106 can be fully seated (i.e., installed) into the housing 102. The seal member 114 and the housing sealing surface 120 mesh in a keyed manner. If a filter element having a totally flat seal member or a seal member having a different contoured pattern (i.e., a non-approved, a non-genuine, non-authorized, etc.) is attempted to be installed in the housing 102, the filter element will not be able to be fully seated into the housing 102 or may not form a proper seal with the housing 102.

[0027] Similarly, as shown in FIGS. 7 and 8, the cover 104 has a cover sealing surface 130. The cover sealing surface 130 includes a planar portion 132 and non-planar portions 134 on two of four sides of the cover sealing surface 130. In some arrangements, the non-planar portions 134 are comprised of multiple planar sub-portions arranged at different angles relative to each other (e.g., to form a vertex, to form a plateau, etc.). In other arrangements, the non-planar portions 134 are comprised of a curved portion. The curved portions may be formed by an extension on the cover 104. In some arrangements, the curved portions are arched in shape. In such arrangements, the curved portions may be concave recessed slits. The planar portion 132 and the non-planar portions 134 are sized and shaped to be complimentary to a corresponding planar portion 126 and non-planar portions 128 of the seal member 114. The non-planar portions 134 and 128 help align the cover 104 with respect to the filter element 106 during installation. Since the filter element 106 and the cover 104 have complimentary sealing surfaces, the cover 104 can be fully seated against the filter element 106 and secured to the housing 102 (e.g., via fasteners, clamps, bolts, snap-fit connections, etc.). The seal member 114 and the cover sealing surface 130 mesh in a keyed manner. As shown best in FIG. 8, the arched portion 128 of the seal member 114 may be supported by an extension portion 136 of the seal member 114.

[0028] Referring to FIG. 9, a cross-sectional view of the sealing area of the filtration system 100 with the filter element 106 installed is shown. As shown more clearly in FIG. 9, the contoured portions of the seal member 114 complementarily interact with the corresponding contoured portions of the cover 104 and the housing 102 to form seals between the filter

element 106 and the cover 104 and the filter element 106 and the housing 102. A filter element without the matching contours would not fit in the filtration system 100.

[0029] Although the filter element 106 is shown as having a seal member 114 with four non-planar portions (two on two opposite sides), it should be understood that any number of non-planar portions may be used so long as the housing 102 and cover 104 having a matching number of non-planar portions aligned with the non-planar portions of the seal member 114 so as to allow the filter element 106 to be installed in the filtration system 100. Additionally, the non-planar portions may be symmetrical or varying in size across the housing 102, the cover 104, and the seal member 114.

[0030] The above described filtration system 100 allows only an authorized or approved filter element, such as the filter element 106, to be installed in the filtration system 100. The authorized filter element 106, the housing 102, and the cover 104 have matching non-planar sealing surfaces that help orient and stabilize the filter element 106 during installation, provide improved dimensional stability of the seal member 114, the housing 102, and/or the cover 104, and provides a one-way-only fit for the filter element 106 in the filtration system 100. The seal member 114 also has an increased surface area, which results in improved sealing against the housing 102 and the cover 104.

[0031] FIG. 10 shows a filtration system 200 according to another embodiment in a partially disassembled state. The filtration system 200 includes a housing 202, a cover 204 removably coupled to the housing 202, and a filter element 206 installed in the filtration system 200. FIG. 11 shows the cover 204 removed from the housing 202, and the FIG. 12 shows a portion of the filter element 206.

[0032] The housing 202 includes an outlet 208. The cover 204 includes an inlet 210. The housing 202 generally defines a central compartment configured to receive the filter element 206. When the filtration system 200 is fully assembled, fluid to be filtered (e.g., air) flows into the inlet 210, through the filter element 206, and out of the outlet 208. The outlet 208 may be in fluid communication with a downstream component, such as an internal combustion engine.

[0033] As shown in in FIG. 12, the filter element 206 comprises filter media 212 and a seal member 214. The filter media 212 may be, for example, pleated filter media arranged in a panel or pleat block. Although shown as being generally rectangular in shape, the filter element 206 may be arranged in other shapes, such as a cylinder, an oval, or the like.

[0034] The seal member 214 is comprised of and attached to the filter media 212 with an adhesive, such as polyurethane. In some arrangements, the seal member 214 includes an embedded frame member or stiffening member to help maintain the shape of the seal member 214. In further or additional arrangements, the seal member 214 is connected to the filter media 212 through an intermediate frame member, such as a circumferential support.

[0035] As described in further detail below, the seal member 214 generally includes both planar portions and non-planar portions (i.e., curved, arched, contoured, portions comprised of multiple intersecting sub-portions, etc.) portions configured to interact with matching planar and curved surfaces of the housing 202 and the cover 204. The seal member 214 may be an axial seal member configured to form a seal with the housing 202 and the cover 204 such that fluid being filtered through the filtration system 200 cannot bypass the filter element 206.

[0036] The filter element 206 may be substantially similar in structure and function to the filter element 106 apart from the following difference. The filter element 206 also comprises a plurality of handles 216 extending axially from an end of the filter element 206 towards the cover 204. In some embodiments, the plurality of handles 216 may be coupled to the seal member 214 or monolithically formed therewith (e.g., molded with the seal member 214). In other embodiments, the plurality of handles 216 may be coupled to the intermediate frame member or any other support structure of the filter element 206. The plurality of handles 216 may facilitate insertion and/or removal of the filter element 206 from the central compartment of the housing 202.

[0037] The filter media 212 of the filter element 206 is inserted into the central compartment of the housing 202. The housing 202 includes a housing sealing surface 220 including a planar portion 222 and non-planar portions 224 on two of four sides of the housing sealing surface 120. The planar portion 222 and the non-planar portions 224 are sized and shaped to be

complimentary to a corresponding planar portion 226 and non-planar portions 228 of the seal member 214. The housing 202 may be substantially similar in structure and function to the housing 102 and therefore not described in further detail herein.

[0038] The cover 204 also has a cover sealing surface including a planar portion and non-planar portions on two of four sides of the cover sealing surface. The planar portion and the non-planar portions are sized and shaped to be complimentary to a corresponding planar portion 226 and non-planar portions 228 of the seal member 214. The cover 204 may be substantially similar in structure and function to the cover 104 and therefore not described in further detail herein.

[0039] FIG. 13 is a schematic flow diagram of an example method 300 for providing a filtration system (e.g., the filtration system 100, 200). The method 300 comprises providing a housing defining a central compartment and an outlet, and further comprising a housing sealing surface having a first non-planar surface, at 302. For example, the housing 102, 202 defining the central compartment and the outlet 108, 208 is provided. The housing 102, 202 comprises the housing sealing surface 120, 220 having a first non-planar surface that includes planar portions 222 and non-planar portions 224, as previously described herein.

[0040] At 304, a cover defining an inlet and comprising a cover sealing surface having a second non-planar surface is provided. For example, the cover 104, 204 defining the inlet 110, 210 and having the cover sealing surface 130 is provided. The cover sealing surface 130 includes the planar portions 132 and non-planar portions 134, as previously described herein.

[0041] At 306, a filter media of a filter element is positioned in the central compartment of the housing. The filter element also comprises a seal member comprising a complimentary non-planar sealing surface that matches the first non-planar surface and the second non-planar surface. For example, the filter media 112, 212 of the filter element 106, 206 is positioned in the central compartment of the housing 102, 202. The filter element 106, 206 also comprises the seal member 114, 214 having the complimentary non-planar sealing surface that includes planar portions 226 and non-planar portions 228 generally corresponding to the planar portions

122, 222, 132 and non-planar portions 124, 224, 134 of the housing 102 and the cover 104, respectively.

[0042] At 308, the cover is coupled to the outlet of the housing such that the seal member is axially pinched between the housing and the cover by the housing sealing surface and the cover sealing surface so as to form a first seal between the seal member and the housing and a second seal between the seal member and the cover. For example, the cover 104, 204 is coupled to the housing 102, 202 such that the seal member 114, 214 is pinched between the housing 102, 202 and the cover 104, 204 by the housing sealing surface 120, 220 and the cover sealing surface 130, as previously described herein.

[0043] It should be noted that any use of the term “example” herein to describe various embodiments is intended to indicate that such embodiments are possible examples, representations, and/or illustrations of possible embodiments (and such term is not intended to connote that such embodiments are necessarily extraordinary or superlative examples).

[0044] The terms “coupled” and the like as used herein mean the joining of two members directly or indirectly to one another. Such joining may be stationary (e.g., permanent) or moveable (e.g., removable or releasable). Such joining may be achieved with the two members or the two members and any additional intermediate members being integrally formed as a single unitary body with one another or with the two members or the two members and any additional intermediate members being attached to one another.

[0045] References herein to the positions of elements (e.g., “top,” “bottom,” “above,” “below,” etc.) are merely used to describe the orientation of various elements in the FIGURES. It should be noted that the orientation of various elements may differ according to other example embodiments, and that such variations are intended to be encompassed by the present disclosure.

[0046] It is important to note that the construction and arrangement of the various example embodiments are illustrative only. Although only a few embodiments have been described in detail in this disclosure, those skilled in the art who review this disclosure will readily

appreciate that many modifications are possible (e.g., variations in sizes, dimensions, structures, shapes and proportions of the various elements, values of parameters, mounting arrangements, use of materials, colors, orientations, etc.) without materially departing from the novel teachings and advantages of the subject matter described herein. For example, elements shown as integrally formed may be constructed of multiple parts or elements, the position of elements may be reversed or otherwise varied, and the nature or number of discrete elements or positions may be altered or varied. The order or sequence of any process or method steps may be varied or re-sequenced according to alternative embodiments. Additionally, features from particular embodiments may be combined with features from other embodiments as would be understood by one of ordinary skill in the art. Other substitutions, modifications, changes and omissions may also be made in the design, operating conditions and arrangement of the various example embodiments without departing from the scope of the present invention.

WHAT IS CLAIMED IS:

1. A filtration system comprising:
 - a housing defining a central compartment and an outlet and comprising a housing sealing surface having a first non-planar surface;
 - a cover removably coupled to the housing, the cover defining an inlet and comprising a cover sealing surface having a second non-planar surface; and
 - a filter element comprising filter media and a seal member, the filter element removably received in the central compartment, the seal member comprising a complimentary non-planar sealing surface that matches the first non-planar surface and the second non-planar surface, the seal member axially pinched between the housing and the cover by the housing sealing surface and the cover sealing surface to form a first seal between the seal member and the housing and a second seal between the seal member and the cover.
2. The filtration system of claim 1, wherein each of the first non-planar surface and the second non-planar surface comprise a planar portion and a non-planar portion.
3. The filtration system of claim 2, wherein the planar portion and the non-planar portion are defined on at least two of four sides of the first non-planar surface and the second non-planar surface.
4. The filtration system of claim 2, wherein each of the first non-planar surface and the second non-planar surface comprise a plurality of non-planar portions positioned symmetrically across the first non-planar surface and the second non-planar surface.
5. The filtration system of claim 2, wherein the non-planar portion comprises an arched surface.

6. The filtration system of claim 5, wherein the non-planar portion comprises a concave recessed slit.
7. The filtration system of claim 2, wherein the non-planar portion comprises a curved surface.
8. The filtration system of claim 2, wherein the non-planar portion comprises a plurality of intersecting planar sub-sections.
9. The filtration system of claim 1, wherein the filter element further comprises at least one handle extending axially from an end of the filter element towards the cover.
10. A filter element removably receivable within a central compartment of a housing, comprising:
 - filter media; and
 - a seal member, the seal member comprising a complimentary non-planar sealing surface that matches (a) a first non-planar surface of a housing sealing surface of the housing and (b) a second non-planar surface of a cover sealing surface of a cover that is removably coupleable to the housing,
 - wherein, when the filter element, the housing, and the cover are in a fully assembled state, the seal member is axially pinched between the housing and the cover by the housing sealing surface and the cover sealing surface to form a first seal between the seal member and the housing and a second seal between the seal member and the cover.
11. The filter element of claim 10, wherein the complimentary non-planar sealing surface comprises a planar portion and a non-planar portion.
12. The filter element of claim 11, wherein the planar portion and the non-planar portion are defined on at least two of four side sides of the complimentary non-planar sealing surface.

13. The filter element of claim 11, wherein the complimentary non-planar sealing surface comprises a plurality of non-planar portions positioned symmetrically across the complimentary non-planar sealing surface.
14. The filter element of claim 11, wherein the non-planar portion comprises an arched surface.
15. The filter element of claim 14, wherein the non-planar portion comprises a concave recessed slit.
16. The filter element of claim 11, wherein the non-planar portion comprises a curved surface.
17. The filter element of claim 11, wherein the non-planar portion comprises a plurality of intersecting planar sub-sections.
18. The filter element of claim 10, further comprising at least one handle extending axially from an end of the filter element towards the cover.
19. A method, comprising:
 - providing a housing defining a central compartment and an outlet, the housing comprising a housing sealing surface having a first non-planar surface;
 - providing a cover defining an inlet and comprising a cover sealing surface having a second non-planar surface;
 - positioning a filter media of a filter element in the central compartment, the filter element also comprising a seal member, the seal member comprising a complimentary non-planar sealing surface that matches the first non-planar surface and the second non-planar surface; and
 - coupling the cover to the housing such that the seal member is axially pinched between the housing and the cover by the housing sealing surface and the cover sealing surface so as to

form a first seal between the seal member and the housing and a second seal between the seal member and the cover.

20. The method of claim 19, wherein the complimentary non-planar sealing surface comprises a planar portion and a non-planar portion.

21. The method of claim 20, wherein the non-planar portion comprises an arched surface.

22. The method of claim 20, wherein the non-planar portion comprises a concave recessed slit.

23. The method of claim 20, wherein the non-planar portion comprises a curved surface.

24. The method of claim 20, wherein the non-planar portion comprises a plurality of intersecting planar sub-sections.

25. The method of claim 19, wherein the filter element further comprises at least one handle extending axially from an end of the filter element towards the cover.

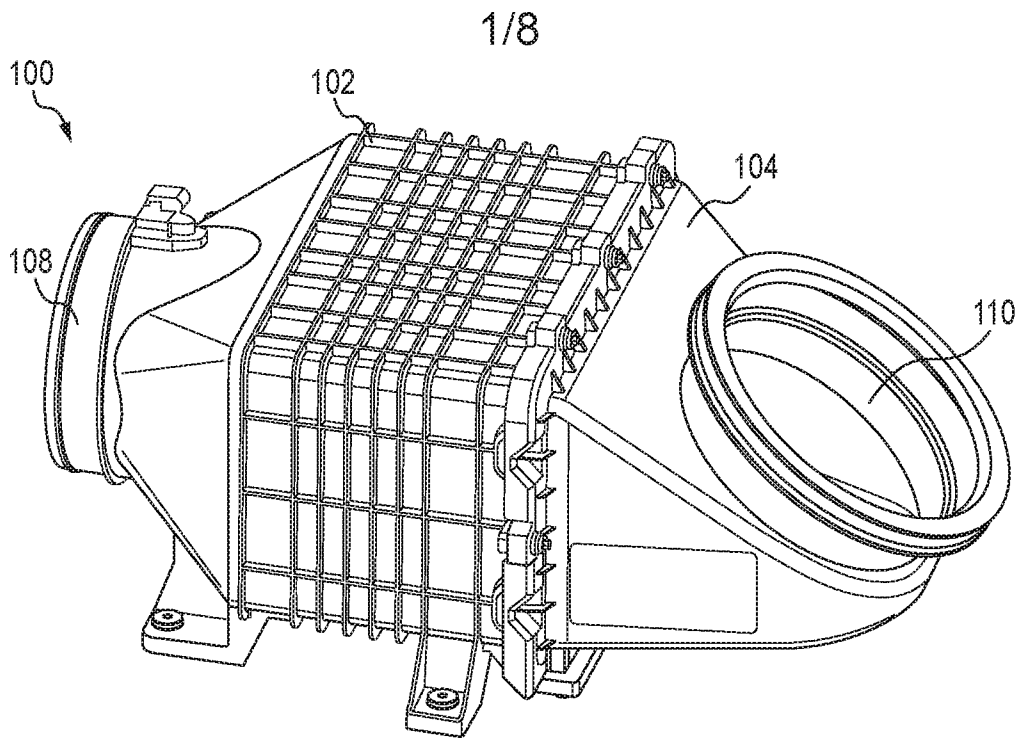

FIG. 1

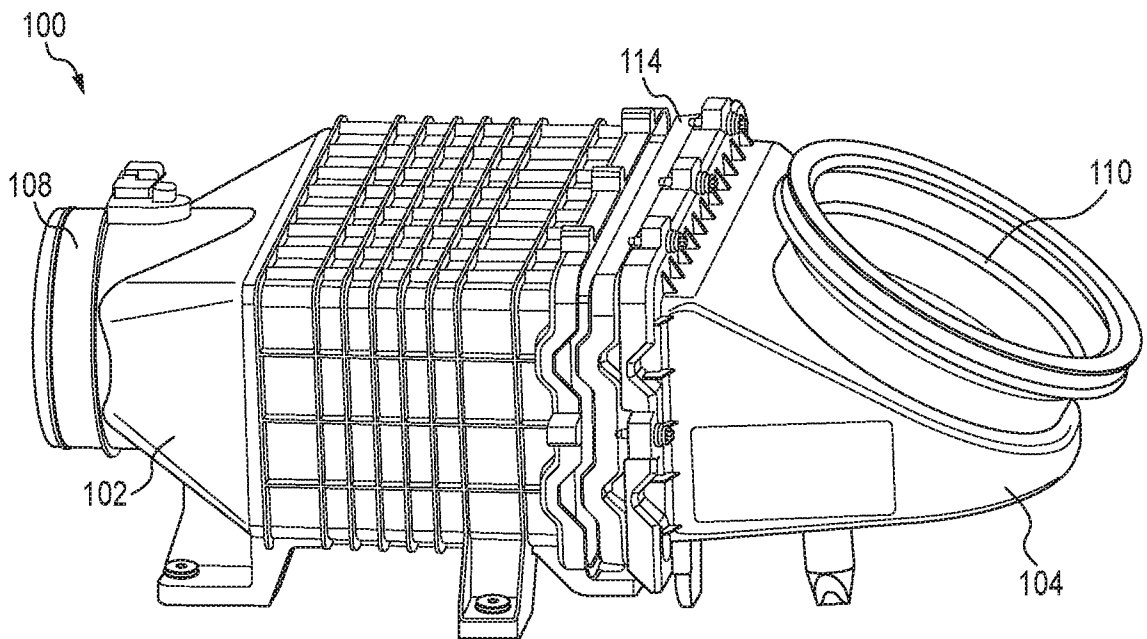

FIG. 2

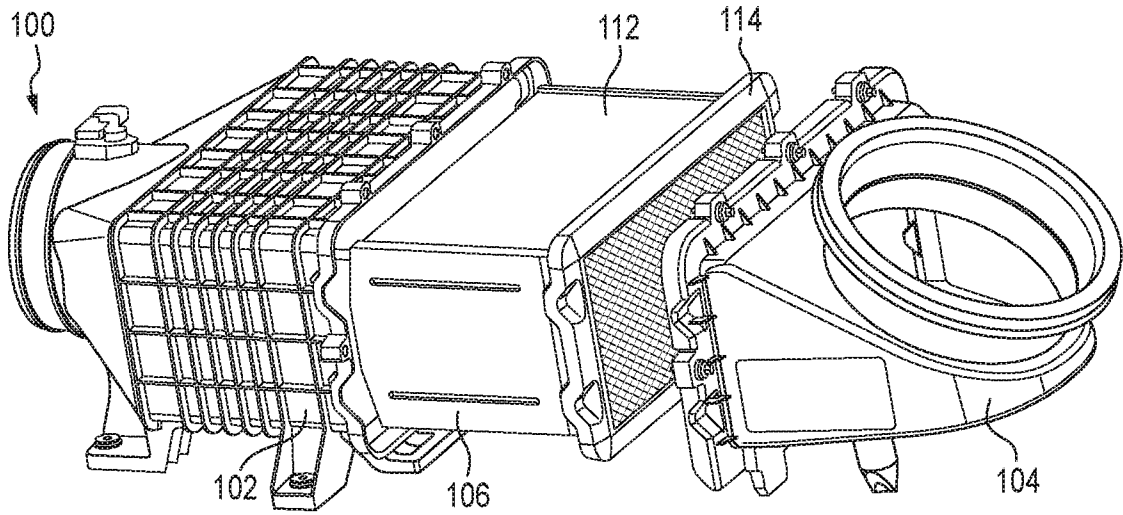

FIG. 3

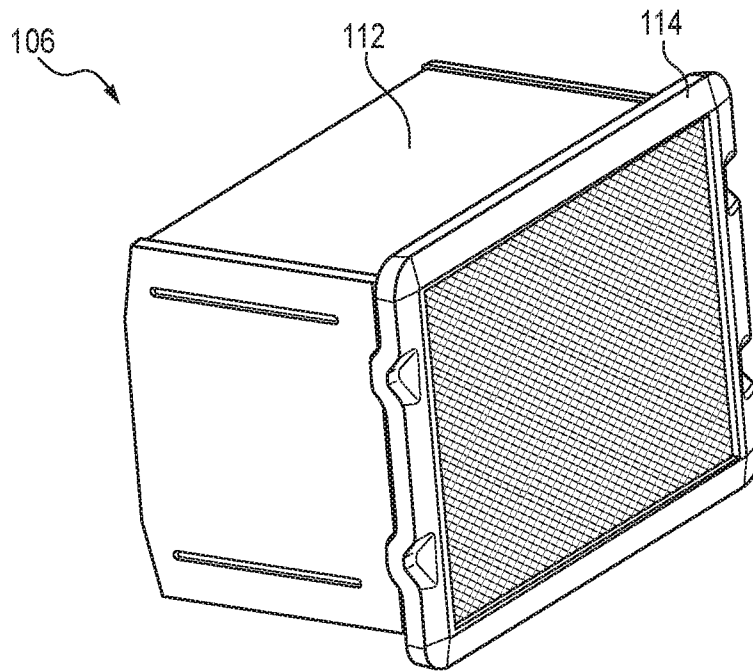

FIG. 4

3/8

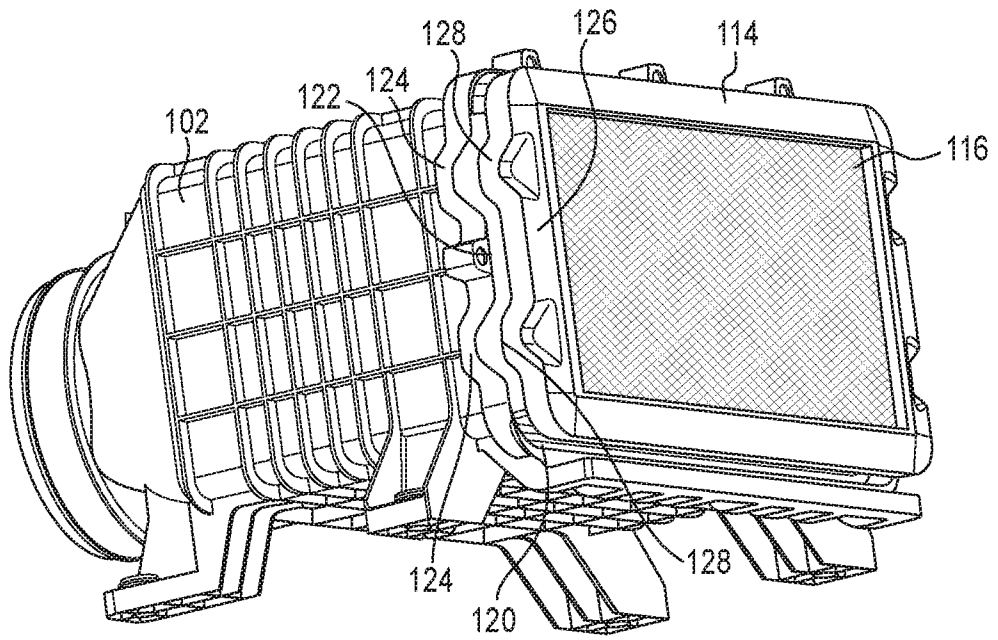

FIG. 5

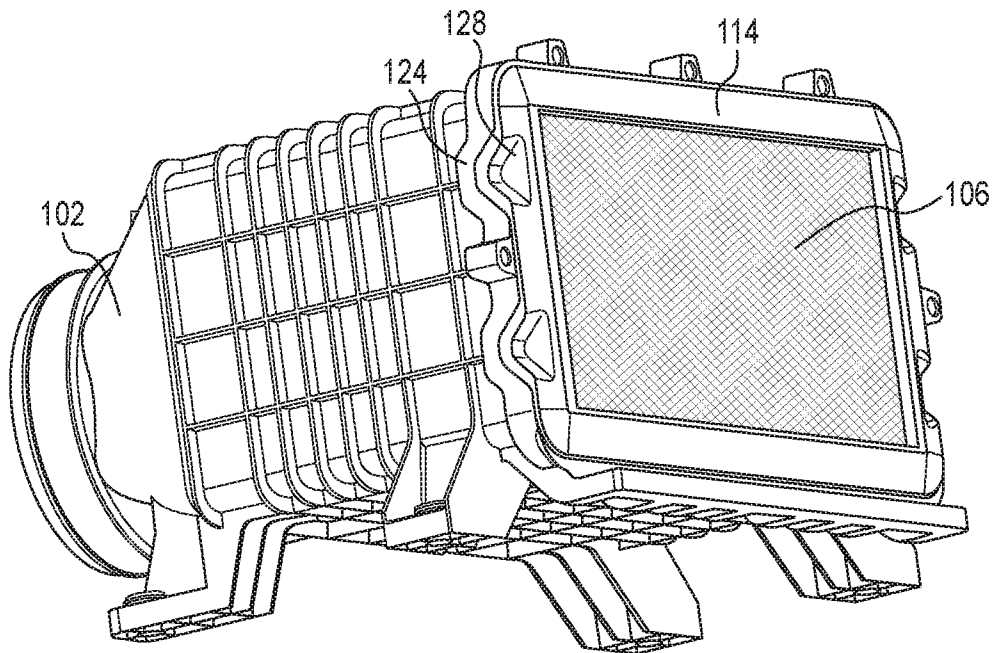
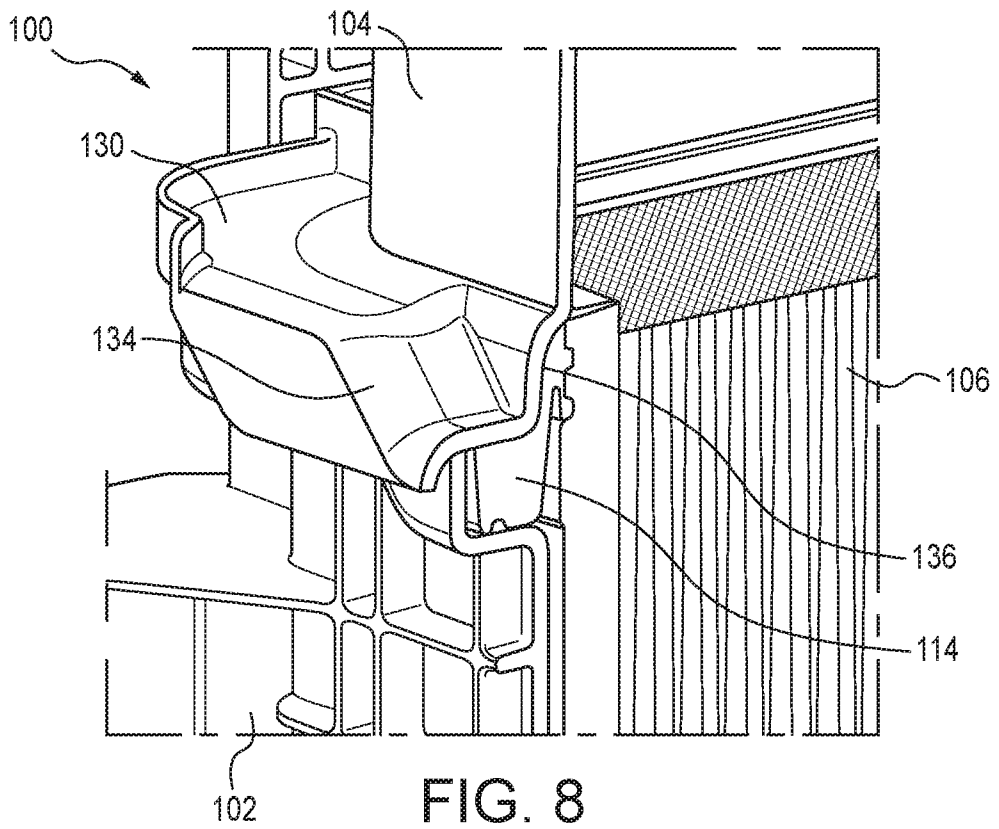
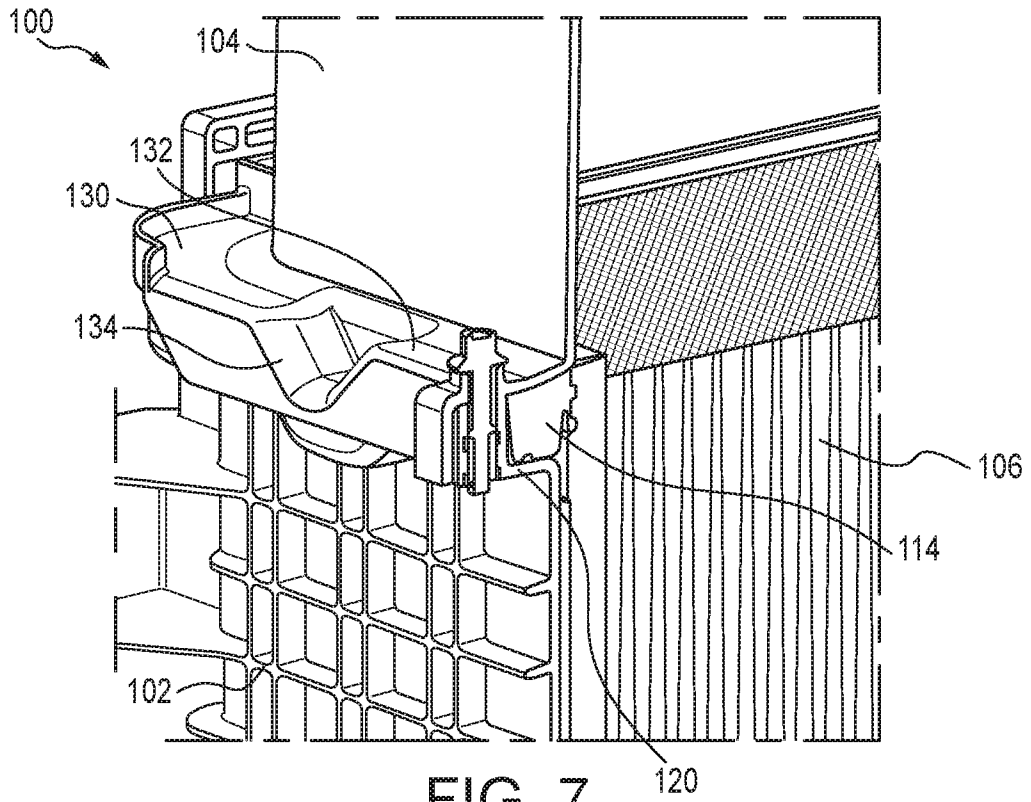

FIG. 6

4/8



5/8

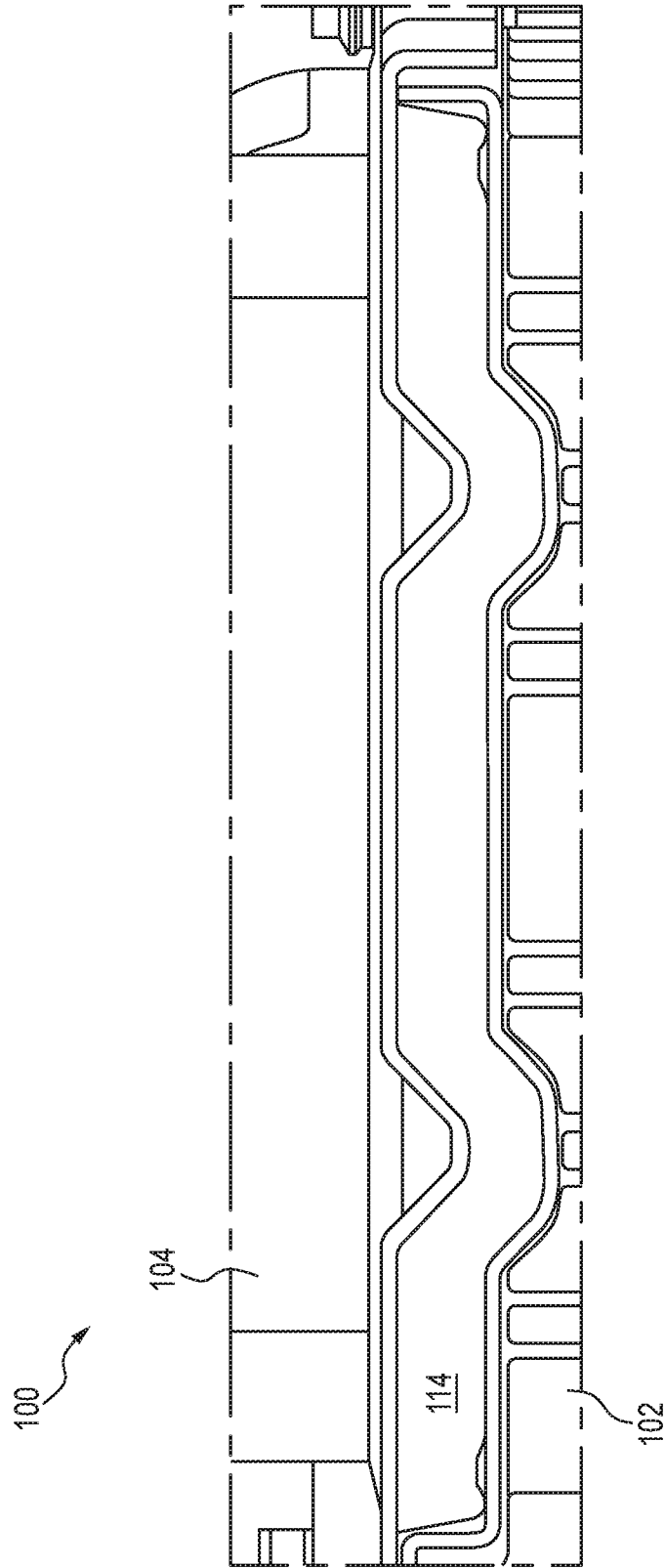

FIG. 9

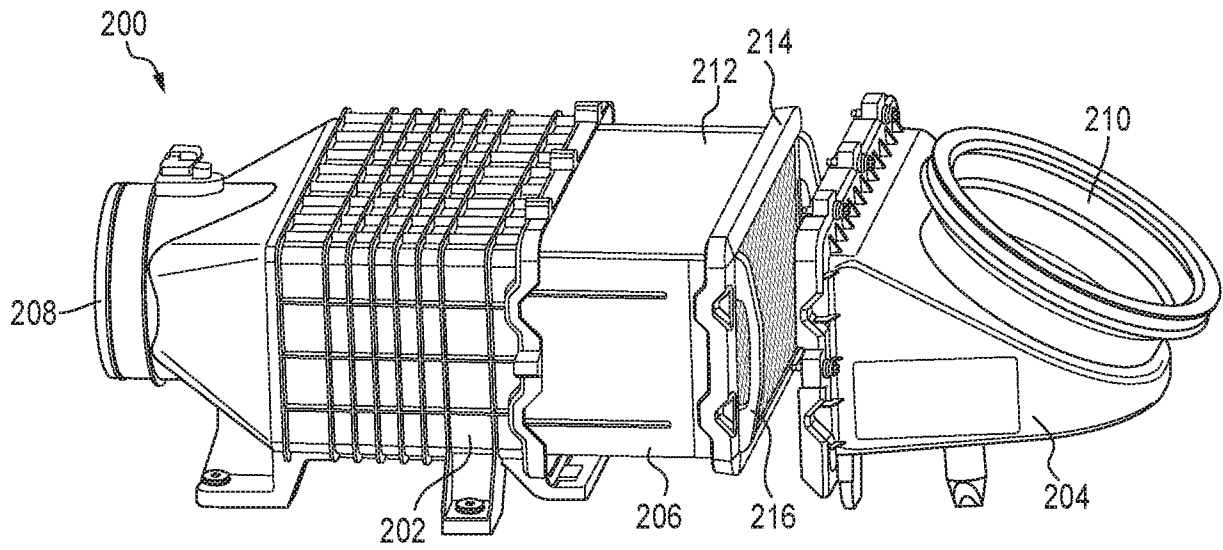

FIG. 10

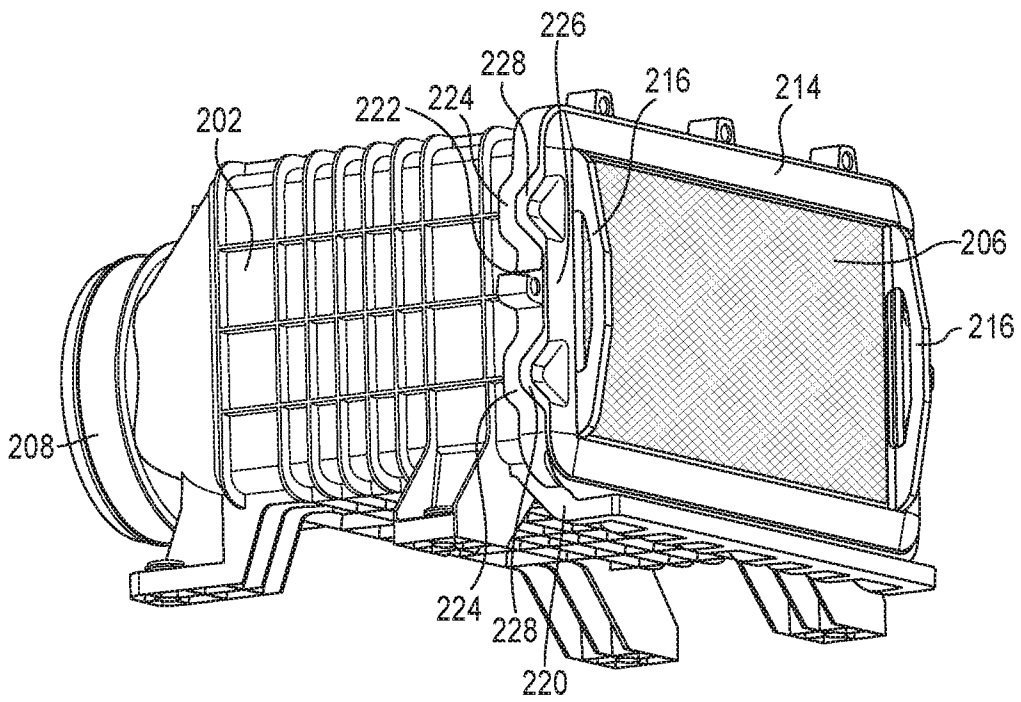

FIG. 11

7/8

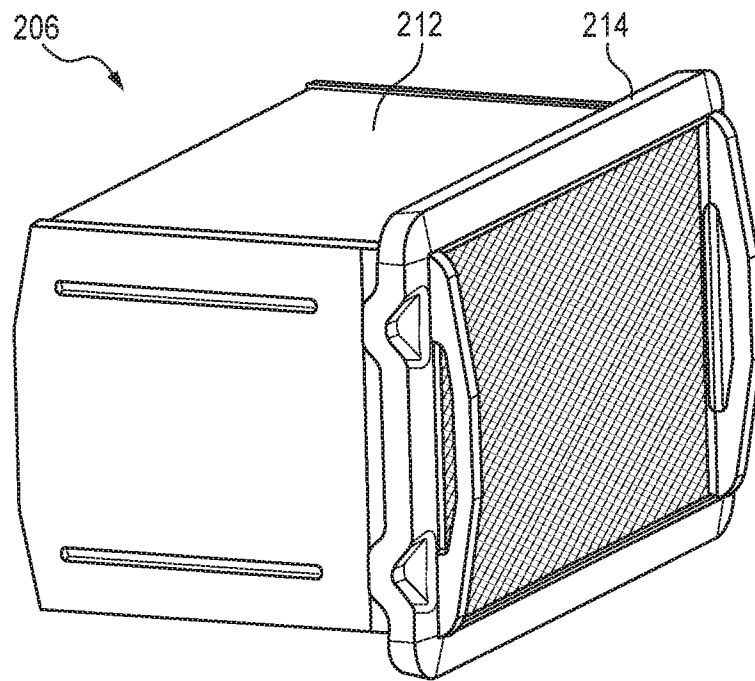

FIG. 12

8/8

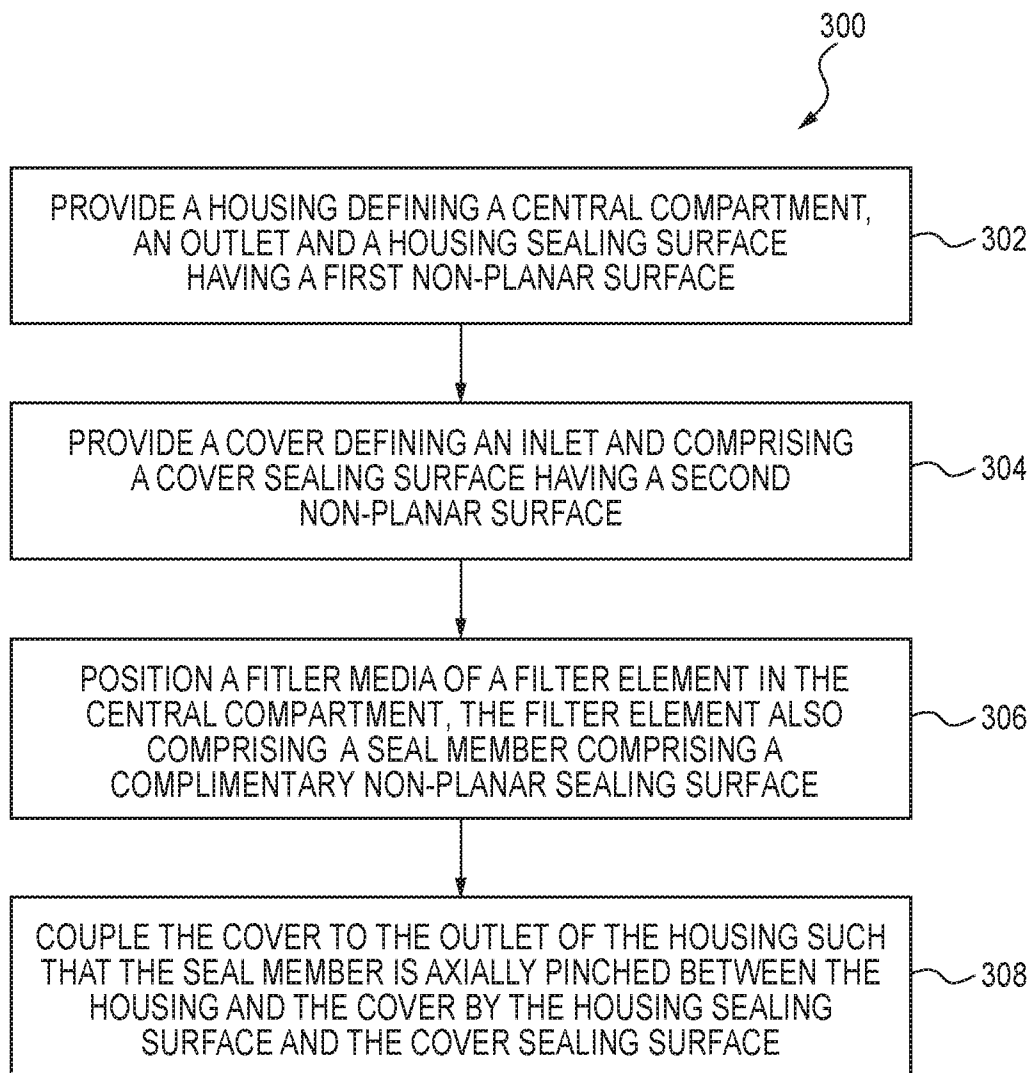

FIG. 13

INTERNATIONAL SEARCH REPORT

International application No.

PCT/US18/18696

A. CLASSIFICATION OF SUBJECT MATTER IPC - B01D 35/02, 35/30 (2018.01) CPC - B01D 35/02, 35/30, 46/0002		
According to International Patent Classification (IPC) or to both national classification and IPC		
B. FIELDS SEARCHED		
Minimum documentation searched (classification system followed by classification symbols) See Search History document		
Documentation searched other than minimum documentation to the extent that such documents are included in the fields searched See Search History document		
Electronic data base consulted during the international search (name of data base and, where practicable, search terms used) See Search History document		
C. DOCUMENTS CONSIDERED TO BE RELEVANT		
Category*	Citation of document, with indication, where appropriate, of the relevant passages	Relevant to claim No.
X --- Y	US 2015/0013289 A1 (MANN+HUMMEL GMBH) 15 January 2015; figures 1, 4; paragraphs [0138], [0140], [0143]	1-5, 7-8, 10-14, 16-17, 19-21, 23-24 --- 6, 9, 15, 18, 22, 25
Y	US 2016/0059172 A1 (CATERPILLAR INC) 03 March 2016; figure 2; paragraphs [0038]-[0039]	6, 15, 22
Y	US 2008/0110142 A1 (NELSON, BK et al) 15 May 2008; figures 8, 12; paragraphs [0090], [0105]	9, 18, 25
A	US 2016/0045848 A1 (DONALDSON COMPANY, INC) 18 February 2016; entire document	1-25
A	US 2014/0251895 A1 (MANN+HUMMEL GMBH) 11 September 2014; entire document	1-25
A	US 2012/0061307 A1 (KINDKEPPEL, CJ et al) 15 March 2012; entire document	1-25
<input type="checkbox"/> Further documents are listed in the continuation of Box C. <input type="checkbox"/> See patent family annex.		
* Special categories of cited documents: "A" document defining the general state of the art which is not considered to be of particular relevance "E" earlier application or patent but published on or after the international filing date "L" document which may throw doubts on priority claim(s) or which is cited to establish the publication date of another citation or other special reason (as specified) "O" document referring to an oral disclosure, use, exhibition or other means "P" document published prior to the international filing date but later than the priority date claimed "T" later document published after the international filing date or priority date and not in conflict with the application but cited to understand the principle or theory underlying the invention "X" document of particular relevance; the claimed invention cannot be considered novel or cannot be considered to involve an inventive step when the document is taken alone "Y" document of particular relevance; the claimed invention cannot be considered to involve an inventive step when the document is combined with one or more other such documents, such combination being obvious to a person skilled in the art "&" document member of the same patent family		
Date of the actual completion of the international search 26 March 2018 (26.03.2018)		Date of mailing of the international search report 19 APR 2018
Name and mailing address of the ISA/ Mail Stop PCT, Attn: ISA/US, Commissioner for Patents P.O. Box 1450, Alexandria, Virginia 22313-1450 Facsimile No. 571-273-8300		Authorized officer Shane Thomas PCT Helpdesk: 571-272-4300 PCT OSP: 571-272-7774