



- (51) International Patent Classification:
E21B 10/26 (2006.01)
- (21) International Application Number:
PCT/US2015/026061
- (22) International Filing Date:
16 April 2015 (16.04.2015)
- (25) Filing Language:
English
- (26) Publication Language:
English
- (30) Priority Data:
61/980,256 16 April 2014 (16.04.2014) US
- (71) Applicant: NATIONAL OILWELL DHT, L.P.
[US/US]; 7909 Parkwood Circle Drive, Houston, TX
77036 (US).
- (72) Inventor: REZA, Rahmani; 519 Oak Ridge Grove Circle,
Spring, TX 77386 (US).
- (74) Agent: SALAZAR, Jennie; The JL Salazar Law Firm,
1934 W. Gray, Suite 401, Houston, TX 77019 (US).
- (81) Designated States (unless otherwise indicated, for every
kind of national protection available): AE, AG, AL, AM,

AO, AT, AU, AZ, BA, BB, BG, BH, BN, BR, BW, BY, BZ, CA, CH, CL, CN, CO, CR, CU, CZ, DE, DK, DM, DO, DZ, EC, EE, EG, ES, FI, GB, GD, GE, GH, GM, GT, HN, HR, HU, ID, IL, IN, IR, IS, JP, KE, KG, KN, KP, KR, KZ, LA, LC, LK, LR, LS, LU, LY, MA, MD, ME, MG, MK, MN, MW, MX, MY, MZ, NA, NG, NI, NO, NZ, OM, PA, PE, PG, PH, PL, PT, QA, RO, RS, RU, RW, SA, SC, SD, SE, SG, SK, SL, SM, ST, SV, SY, TH, TJ, TM, TN, TR, TT, TZ, UA, UG, US, UZ, VC, VN, ZA, ZM, ZW.

(84) Designated States (unless otherwise indicated, for every kind of regional protection available): ARIPO (BW, GH, GM, KE, LR, LS, MW, MZ, NA, RW, SD, SL, ST, SZ, TZ, UG, ZM, ZW), Eurasian (AM, AZ, BY, KG, KZ, RU, TJ, TM), European (AL, AT, BE, BG, CH, CY, CZ, DE, DK, EE, ES, FI, FR, GB, GR, HR, HU, IE, IS, IT, LT, LU, LV, MC, MK, MT, NL, NO, PL, PT, RO, RS, SE, SI, SK, SM, TR), OAPI (BF, BJ, CF, CG, CI, CM, GA, GN, GQ, GW, KM, ML, MR, NE, SN, TD, TG).

Published:
— without international search report and to be republished upon receipt of that report (Rule 48.2(g))



WO 2015/161010 A2

(54) Title: DOWNHOLE DRILL BIT CUTTING ELEMENT WITH CHAMFERED RIDGE

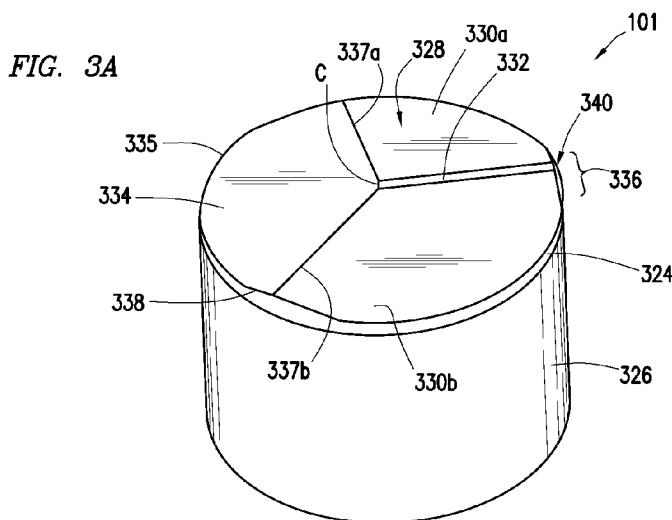

(57) Abstract: A cutting element for a drill bit is advanceable into a subterranean formation to form a wellbore. The cutting element includes an element body having a face at an end thereof, and a ridge. The element body has a face at an end thereof. The face has a ramp and a pair of side regions thereon. The ramp has a curved edge along a periphery of the face and two sides. Each of the two sides extends from opposite ends of the curved edge and converges at a location along the face. The face has a chamfer along a peripheral edge thereof. The ridge is between the chamfer and the location. Each of the pair of side regions is positioned on opposite sides of the ridge and extends between the periphery, the ridge, and one of the two sides of the ramp whereby the chamfer engages a wall of the wellbore and extrudate is drawn along the pair of side regions.

DOWNHOLE DRILL BIT CUTTING ELEMENT WITH CHAMFERED RIDGE
CROSS-REFERENCE TO RELATED APPLICATIONS

[0001] This application claims the benefit of US Provisional Application No. 61/980,256, filed on April 16, 2014, the entire contents of which are hereby incorporated by reference herein.

BACKGROUND

[0002] This present disclosure relates generally to drilling equipment used in wellsite operations. More specifically, the present disclosure relates to drill bits and cutting elements used for drilling wellbores.

[0003] Various oilfield operations may be performed to locate and gather valuable downhole fluids. Oil rigs are positioned at wellsites and downhole tools, such as drilling tools, are deployed into the ground to reach subsurface reservoirs. The drilling tool may include a drill string with a bottom hole assembly, and a drill bit advanced into the earth to form a wellbore. The drill bit may be connected to a downhole end of the bottom hole assembly and driven by drillstring rotation from surface and/or by mud flowing through the drilling tool.

[0004] The drill bit may be a fixed cutter drill bit with polycrystalline diamond compact (PDC) cutting elements. An example of a drill bit and/or cutting element are provided in US Application No. 61/694,652, filed Aug. 29, 2012, entitled Cutting Element for a Rock Drill Bit, published in WO 2014/036283, March 6, 2014, the entire contents of which are hereby incorporated by reference herein. Other examples of drill bits and/or cutting elements are provided in WO2012/056196, WO2012/012774, and US Patent Application Nos. 2012/0018223, 2011/0031028, 2011/0212303, 2012/0152622, and/or 2010/0200305, the entire contents of which are hereby incorporated by reference herein.

SUMMARY

[0005] In at least one aspect, the disclosure relates to a cutting element for a drill bit advanceable into a subterranean formation to form a wellbore. The cutting element includes an element body having a face at an end thereof, and a ridge. The element body has a face at an end thereof. The face has a ramp and a pair of side regions thereon. The ramp has a curved edge along a periphery of the face and two sides. Each of the two sides extends from opposite ends of the

curved edge and converges at a location along the face. The face has a chamfer along a peripheral edge thereof. The ridge is between the chamfer and the location. Each of the pair of side regions is positioned on opposite sides of the ridge and extends between the periphery, the ridge, and one of the two sides of the ramp whereby the chamfer engages a wall of the wellbore and extrudate is drawn along the pair of side regions.

[0006] The element body may include a substrate, and/or a diamond layer with the face positioned along a surface of the diamond layer. A ramp angle may be defined between the sides of the ramp (e.g., at about 60 to 90 degrees). A surface angle may be defined along the side regions between the ridge and one of the two sides of the ramp (e.g., at about 135 degrees). A chamfer angle may be defined between a horizontal line and a face of the chamfer (e.g., at about 45 degrees). The ramp and the sides may incline along the periphery. The ramp and the sides may incline along the periphery at an angle of about 10 degrees. The ramp and/or the side regions may be flat and/or have a curved surface.

[0007] The location may be positioned about a center of the face or a distance therefrom. The sides may be along a radius of the face. The ridge may be along a radius of the face. The ridge may have a width of 0.40 mm, and/or a height of 0.30 mm. The ridge may have a length 1/2 of a diameter of the face, or less than 1/2 of a diameter of the face. The ridge may have a width that narrows or widens away from a center of the face. The chamfer may extend along the periphery between 10 and 360 degrees of the periphery of the face. The chamfer may define a leading edge of the cutting element for engagement with a wall of the wellbore. A bottom of the element body opposite the face has a bevel.

[0008] In another aspect, the drill bit is advanceable into a subterranean formation to form a wellbore. The drill bit includes a bit body and at least one cutting element disposable in the bit body. The cutting element includes an element body having a face at an end thereof, and a ridge. The element body has a face at an end thereof. The face has a ramp and a pair of side regions thereon. The ramp has a curved edge along a periphery of the face and two sides. Each of the two sides extends from opposite ends of the curved edge and converges at a location along the face. The face has a chamfer along a peripheral edge thereof. The ridge is between the chamfer and the location. Each of the pair of side regions is positioned on opposite sides of the ridge and extends between the periphery, the ridge, and one of the two sides of the ramp whereby the chamfer engages a wall of the wellbore and extrudate is drawn along the pair of side regions.

[0009] The bit body may have blades extending radially therefrom, and/or at least one socket to receive the at least one cutting element therein.

[0010] Finally, in another aspect, the disclosure relates to a method of advancing a drill bit advanceable into a subterranean formation to form a wellbore. The method involves providing the drill bit with at least one cutting element. The cutting element includes an element body having a face at an end thereof, and a ridge. The element body has a face at an end thereof. The face has a ramp and a pair of side regions thereon. The ramp has a curved edge along a periphery of the face and two sides. Each of the two sides extends from opposite ends of the curved edge and converges at a location along the face. The face has a chamfer along a peripheral edge thereof. The ridge is between the chamfer and the location. Each of the pair of side regions is positioned on opposite sides of the ridge and extends between the periphery, the ridge, and one of the two sides of the ramp whereby the chamfer engages a wall of the wellbore and extrudate is drawn along the pair of side regions. The method further involves engaging the chamfer of the drill bit with a wall of the wellbore.

[0011] The method may also involve drawing extrudate from the wall of the wellbore down the pair of side regions, and/or flowing fluid down the ramp and toward the chamfer.

BRIEF DESCRIPTION OF THE DRAWINGS

[0012] So that the above recited features and advantages can be understood in detail, a more particular description, briefly summarized above, may be had by reference to the embodiments thereof that are illustrated in the appended drawings. It is to be noted, however, that the examples illustrated are not to be considered limiting of its scope. The figures are not necessarily to scale and certain features and certain views of the figures may be shown exaggerated in scale or in schematic in the interest of clarity and conciseness.

[0013] FIG. 1 is a schematic diagram of a wellsite including a rig with a downhole tool having a drill bit advanced into the earth to form a wellbore.

[0014] FIGS. 2A and 2B are perspective and end views, respectively, of a fixed cutter drill bit with cutting elements thereon.

[0015] FIGS. 3A-3E are perspective, top, bottom, left side, and rear views of one of the cutting elements having a central configuration.

[0016] FIGS. 4A-4G are additional perspective and plan views of the cutting element of Fig. 3A.

[0017] FIGS. 5A-5E are perspective, top, front, rear, and side views, respectively, of a cutting element having an offset configuration.

[0018] FIGS. 6A-6B are perspective and top views, respectively, of a cutting element having an offset, inward tapered configuration.

[0019] FIGS. 7A-7B are perspective and top views, respectively, of a cutting element having an offset, outward tapered configuration.

[0020] FIG. 8 is a flow chart depicting a method of drilling a wellbore.

DETAILED DESCRIPTION

[0021] The description that follows includes exemplary apparatuses, methods, techniques, and/or instruction sequences that embody techniques of the present subject matter. However, it is understood that the described embodiments may be practiced without these specific details.

[0022] This disclosure is directed to a cutting element (or insert) for a drill bit used to drill wellbores. The cutting element includes a face (or working surface) having at least two side regions with an elongated ridge therebetween, a ramp, and a chamfer. The ridge extends from the chamfer at a periphery of the face to a location along the face (e.g., a central part of the face) to draw extrudates down the pair of side regions. The ramp extends at an angle from the side regions to flow fluid toward the leading edge during drilling.

[0023] Figure 1 depicts a wellsite 100 in which the subject matter of the present disclosure may be used. As generally shown, cutting elements 101 and assemblies and processes employing the cutting elements may be deployed at a downhole end of a downhole tool 102 into a wellbore 104 formed in a subterranean formation 106 by any suitable means, such as by a rotary drill string 108 operated from a drilling rig 110 to rotate a drill bit 112. A mud pit 111 is provided at the wellsite 100 to pass drilling fluid through the downhole tool 102 and out the bit 112 to cool the drill bit 112 and carry away cuttings during drilling.

[0024] The "drill string" may be made up of tubulars secured together by any suitable means, such as mating threads, and the drill bit may be secured at or near an end of the tubulars as secured together. As used throughout this description, the term "wellbore" is synonymous with borehole and means the open hole or uncased portion of a subterranean well including the rock face which bounds the drilled hole. As used throughout this description, the terms "environ" and

"environs" refers to one or more subterranean areas, zones, horizons and/or formations that may contain hydrocarbons.

[0025] The wellbore may extend from the surface of the earth, including a seabed or ocean platform, and may penetrate one or more environs of interest. The wellbore may have any suitable subterranean configuration, such as generally vertical, generally deviated, generally horizontal, or combinations thereof, as will be evident to a skilled artisan.

[0026] The quantity of energy referred to as "energy of extrusion" or "EE" means the portion of the total mechanical specific energy ("MSE") that is expended to extrude crushed rock particles across the faces of the cutting element(s) of the drill bit during drilling. As used throughout this description, the term "extrudate" refers to crushed rock particle conglomerates that are extruded across the face of the cutting element(s) during drilling. As also used throughout this description, the term "rock drill bit" refers to a fixed cutter, drag-type rock drill bit.

[0027] The cutting elements 101 described herein may be utilized in conjunction with any drill bit rotated by means of a drill string to form a wellbore in environs, such as a rotary drag-type rock drill bits. Figures 2A and 2B depict an example drill bit 112 that may be used with the cutting elements 101 described herein. As shown, the drill bit 112 is a drag-type rock drill bit having a bit body 214.

[0028] The bit body 214 may include one or more blades 216 that protrude from an outer periphery of the bit body 214. The blades 216 extend along a portion of the bit body 214 and terminate on or near a nose end 218 thereof. The nose end 218 is at a central location about an end of the bit body 214 where the blades 216 converge. The bit body 214 may also be provided with one or more passages 222 between the blades 216 for transporting drilling fluid to the surface of the bit body 214 for cooling and/or cleaning exposed portions of the cutting elements 101 during drilling operations.

[0029] One or more cutting elements 101 are mounted in at least one of the blades 216 by positioning a portion of each cutting element 101 within a socket 220 and securing it therein by any suitable means as will be evident to a skilled artisan, for example by means of pressure compaction or baking at high temperature into the matrix of the bit body 214. The cutting elements 101 may be positioned in the sockets 220 at a desired orientation.

[0030] The cutting elements 101 may be randomly positioned about the bit body 214. The orientation of the cutting elements 101 may optionally be selected so as to ensure that the leading

edge of each cutting element 101 may achieve its intended depth of cut, or at least be in contact with the rock during drilling. For example, the cutting elements 101 may be oriented in the sockets 220 in the same orientation, such as with a specific portion, such as a leading (or cutting) edge, of each cutting element pointing in the same direction. In another example, the cutting elements 101 may be oriented in a pattern such that a specific point, such as the leading edge of each of the cutting elements 101, points towards the nose 218 and the relative angle of each leading edge is shifted away from the nose 218 the further from the nose 218 the cutting element 101 is positioned. In yet another example, the orientation of the cutting elements 101 positioned about the nose 218 of the drill bit 112 may be offset at an angle, such as about 90 degrees, from an orientation of those cutting elements 101 positioned near a periphery of the bit body 214.

[0031] Figures 3A-3E depict the cutting element 101 in greater detail. Additional views of the cutting element 101 are provided in Figures 4A-4G. A face (or working surface) 328 at an exposed end of each cutting element 101 as mounted in bit body 214 includes geometric partitions of surface area along the face 328, each having a functional role in abrading/shearing, excavating, and removing rock from beneath the drill bit 112 during rotary drilling operations.

[0032] As illustrated, each cutting element 101 includes a diamond (e.g., polycrystalline diamond ("PCD")) layer 324 bonded to a less hard substrate 326. While a single diamond layer 324 and substrate 326 are depicted, one or more layers of one or more materials may be provided as the layer, substrate and/or other portions of the cutting element 101.

[0033] The cutting elements described herein may be formed of various materials. For example, the substrate 326 may be made of tungsten carbide and the diamond layer may be formed of various materials including diamond. Other layers and/or portions of may optionally be provided. Part and/or all of the diamond layer (e.g., chamfer 336) may be leached, finished, polished, and/or otherwise treated to enhance operation. Examples of materials and/or treatments, such as leaching are described in Patent/Application Nos. US 61/694,652, WO 2014/036283, WO2012/056196, WO2012/012774, US2012/0018223, US2011/0031028, US2011/0212303, US2012/0152622, and/or US2010/0200305, the entire contents of which are hereby incorporated by reference herein.

[0034] When inserted into a socket 220 of the bit body 214 as shown in Figures 2A-2B, an element body of the cutting element 101 is positioned with a diamond layer 324 extending outside of the socket 220 and has the face 328 at an end thereof for engagement with the

wellbore. The cutting element 101 may have any suitable general configuration as will be evident to a skilled artisan, for example a generally cylindrical configuration as shown, and with a generally constant diameter D (e.g., about 16 mm) along about the entire length L (e.g., of about 13 mm) thereof.

[0035] The cutting element 101 may include a pair of side regions 330a,b, an elongated ridge 332, a ramp 334, and a chamfer 336 about the face 328. The side regions (or slanted surfaces) 330a,b extend from a periphery 338 of the cutting element 101 a distance therein. The regions 330a,b are generally pie shaped regions defined by an obtuse angle extending from a center C of the face 328 and a portion of the periphery 338. The side regions 330a,b may have any angle, such as a surface angle λ of about 135 degrees, and a slant angle ϕ of about 10 degrees (or from about 2 degrees to about 20 degrees). The regions 330a,b may be symmetrical relative to each other on either side of the ridge 332.

[0036] The ridge 332 is positioned along a side of each of the side regions 330a,b to separate the side regions 330a,b. The ridge 332 may be generally perpendicular to a leading edge 340 of the cutting element, and may be centrally oriented along the face 328. The ridge 332 extends from the leading edge 340, located at the periphery of the face 328, to about the center C of the face 328. The ridge 332 may extend along a portion of the diameter of the face 328, for example, from about 1/3 to 2/3 of a diameter D of the face 328.

[0037] The ridge 332 defines a protrusion extending from the chamfer 336 at the periphery 338 and to the center C of the face 328 between the regions 330a,b. The ridge 332 may have a length LR equal to a radius R of the face 328 and defines a side of the adjacent regions 330a,b. The radius R may have a length of about 8mm. The ridge 332 may have a length defined for bisecting and physically splitting apart extruding rock particle conglomerates or extrudates and directing the smaller, split extrudate portions into the regions 330a,b.

[0038] The ridge 332 may have a uniform width along the entire length thereof and may have uniform height along the entire length thereof, or may possess a height that varies, such as by increasing from the end thereof proximate to the leading edge 340 to an opposite end thereof at a location at or near the ramp 334. The ridge 332 may have a width W of, for example, about 0.50 mm.

[0039] The chamfer 336 extends along a portion of the periphery 338 and defines the leading (or cutting) edge 340. The chamfer 336 as shown extends along about 10 degrees of the periphery

338 and has a height H of about 0.3 mm. The chamfer 336 may extend from about 2 degrees to about 360 degrees of the periphery 338. The leading edge 340 may be a portion of an edge of the cutting element 101 illustrated as being about the chamfer 336. The leading edge 340 may be dimensioned to achieve a generally predetermined depth-of-cut into rock.

[0040] The chamfer 336 may extend from the ridge 332 at a chamfer angle θ of about 45 degrees (or from about 15 degrees to about 75 degrees). The chamfer 336 may be formed along a peripheral end of the ridge 332 at the leading edge 340. By extending the ridge 332 to the periphery 338 of the cutting element 101, at the leading edge 340, the regions 330a,b and the ridge 332 may provide a leading edge 340 defined for splitting of the rock particle conglomerates or extrudates.

[0041] The ramp 334 defines a third pie shaped region extending from a central end of the ridge 332 and between adjacent regions 330a,b. The ramp 334 provides a surface to define rigid back-support and stability to the regions 330a,b. The ramp 334 may extend from the ridge 332 and along the regions 330a,b at a ramp angle α of about 90 degrees between the regions 330a,b. The ramp angle α may also extend at any angle, such as from about 60 degrees to about 120 degrees. The ramp 334 may also have an incline angle β of, for example, of about 10 degrees.

[0042] In the example of Figure 3A, the ramp 334 has a curved edge 335 along a periphery of the face and two sides 337a,b. Each of the two sides 337a,b extend from opposite ends of the curved edge 335 and converging at the location (e.g., center) C along the face 328. The ridge 332 is between the chamfer 336 and the location C. Each of the pair of side regions 330a,b is positioned on opposite sides of the ridge 332 and extends between the periphery 338, the ridge 332, and one of the two sides 337a,b of the ramp 334.

[0043] As shown by these views, the cutting element 101 is in a central configuration with the ridge 332 extending from a central area of the face 328 of the cutting element 101. As shown, the ridge 332 extends from the center C of the face 328 to divide the side regions 330a,b into equal portions. In this configuration, the ramp 334 and the side regions 330a,b are of a similar dimension. The ramp 334 and the side regions 330a,b may have any shape, such as planar (as shown), concave, and/or a combination of curved and/or planar surfaces. The ramp 334 may be shaped to flow drilling fluid toward the ridge 332 and the leading edge 340 and the chamfer 336 may be positioned to engage a wall of the wellbore such that extrudate is drawn along the pair of side regions during operation.

[0044] The cutting element 101 may also be provided with other features and/or geometries. For example, as shown in Figure 3C, the cutting element 101 has a bottom surface (or end) 325 with a bevel 327 along the periphery 338. The bevel 327 may have a bevel angle ψ (in Figure 3E) of about 45 degrees, or at an angle from about 35 degrees to about 50 degrees.

[0045] In operation, drilling fluid passing through the downhole tool 108 and out the drill bit 112 (Figure 1) may flow through the passages 222 and over the cutting element(s) (e.g., 101) in the blades 216 (Figure 2). The leading edge 340 of the cutting element(s) may engage and dislodge rock along the wellbore to form extrudates. The regions (e.g., 330a,b) may direct opposing forces to extrudates at positive non-zero angles to the two-dimensional plane of the leading edge 340. These forces may urge the extrudates into the drilling fluid until such point in time when the surface area of each extrudate exceeds a critical value and the extrudate is broken off into the flow regime of the drilling fluid. The ramp (e.g., 334) may be used to flow the drilling fluid toward the face (or working surface) (e.g., 328) to reduce interfacial friction between the working surface and rock extrudate and carry extrudate away as it is dislodged about the leading edge 340.

[0046] The configuration of the cutting elements may split extrudate in smaller portions without interrupting extrudate formation in such a way that limits the volume and mass (less energy of formation) of the extrudate. In this manner, reduced frictional forces between the cutter working surface and rock extrudate may result in extrudate removal with less EE. Accordingly, less input energy may be required to drill at given rate of penetration, thereby reducing MSE while drilling.

[0047] Figures 5A-7E depict views of additional versions of a cutting element 501, 601, 701. Figures 5A-5E show the cutting element 501 in an offset configuration. Figures 6A-6E show the cutting element 601 having an offset, inward tapered configuration. Figures 7A-7E show the cutting element 701 having an offset, outward tapered configuration. The cutting elements 501, 601, 701 are similar to the cutting element 101, except that the cutting elements 501, 601, 701 may have a ridge 532, 632, 732 positioned a distance from a center of the face 528, 628, 728, and/or may have various shapes.

[0048] In the example of Figures 5A-5E, the cutting element 501 has the face 528 with side portions 530a,b, the ridge 532, and a ramp 534. The cutting element 501 is similar to the cutting element 101, except that the ridge 532 extends from a periphery 538 to a location a distance from the center C. As shown by this example, the ridge 532 may have a length LR1 that is less than

1/2 of the diameter D (and less than the radius R) of the face 528 (e.g., about 1/3 of the diameter D).

[0049] In the example of Figures 6A-6B, the cutting element 601 has the face 628 with side portions 630a,b, the ridge 632, a ramp 634. The cutting element 601 is similar to the cutting element 501, except that a width of the ridge 632 has an inward taper. As shown by this example, the ridge 632 may have a width W2 at the periphery and a wider width W1 at an opposite end.

[0050] In the example of Figures 7A-7B, the cutting element 701 has the face 728 with side portions 730a,b, the ridge 732, a ramp 734. The cutting element 701 is similar to the cutting element 601, except that a width of the ridge 732 has an outward taper. As shown by this example, the ridge 732 may have a width length W3 at the periphery and a narrower width W4 at an opposite end.

[0051] Figure 8 is a flow chart depicting a method 800 of drilling a wellbore. The method involves 840 providing the drill bit with at least one cutting element. The cutting element includes an element body having a face at an end thereof, and a ridge. The element body has a face at an end thereof. The face has a ramp and a pair of side regions thereon. The ramp has a curved edge along a periphery of the face and two sides. Each of the two sides extends from opposite ends of the curved edge and converges at a location along the face. The face has a chamfer along a peripheral edge thereof. The ridge is between the chamfer and the location. Each of the pair of side regions is positioned on opposite sides of the ridge and extends between the periphery, the ridge, and one of the two sides of the ramp.

[0052] The method may also involves 842 engaging the chamfer of the drill bit with a wall of the wellbore, 844 drawing extrudate from the wall of the wellbore down the pair of side regions, and/or 846 flowing fluid down the ramp and toward the chamfer. The method may also involve advancing a drill bit into a subterranean formation to form a wellbore. The method may be performed in any order and repeated as needed.

[0053] While the subject matter has been described with respect to a limited number of embodiments, those skilled in the art, having benefit of this disclosure, will appreciate that other embodiments can be devised which do not depart from the scope of the subject matter as disclosed herein. Accordingly, the scope of the invention should be limited only by the attached claims.

[0054] It will be appreciated by those skilled in the art that the techniques disclosed herein can be implemented for automated/autonomous applications via software configured with algorithms to perform the desired functions. These aspects can be implemented by programming one or more suitable general-purpose computers having appropriate hardware. The programming may be accomplished through the use of one or more program storage devices readable by the processor(s) and encoding one or more programs of instructions executable by the computer for performing the operations described herein. The program storage device may take the form of, e.g., one or more floppy disks; a CD ROM or other optical disk; a read-only memory chip (ROM); and/or other forms of the kind well known in the art or subsequently developed. The program of instructions may be "object code," i.e., in binary form that is executable more-or-less directly by the computer; in "source code" that requires compilation or interpretation before execution; or in some intermediate form such as partially compiled code. The precise forms of the program storage device and of the encoding of instructions are immaterial here. Aspects of the invention may also be configured to perform the described functions (via appropriate hardware/software) solely on site and/or remotely controlled via an extended communication (e.g., wireless, internet, satellite, etc.) network.

[0055] The above description is illustrative of the preferred embodiment and many modifications may be made by those skilled in the art without departing from the invention whose scope is to be determined from the literal and equivalent scope of the claims that follow.

[0056] While the embodiments are described with reference to various implementations and exploitations, it will be understood that these embodiments are illustrative and that the scope of the inventive subject matter is not limited to them. Many variations, modifications, additions and improvements are possible, such as such as location, shape, dimensions, and orientation of the regions, ridge, ramp, chamfer, etc. and materials used in their manufacture. Various combinations of the features provided herein may be utilized.

[0057] Plural instances may be provided for components, operations or structures described herein as a single instance. In general, structures and functionality presented as separate components in the exemplary configurations may be implemented as a combined structure or component. Similarly, structures and functionality presented as a single component may be implemented as separate components. These and other variations, modifications, additions, and improvements may fall within the scope of the inventive subject matter.

CLAIMS

What is Claimed is:

1. A cutting element for a drill bit, the drill bit advanceable into a subterranean formation to form a wellbore, the cutting element comprising:
 - an element body having a face at an end thereof, the face having a ramp and a pair of side regions thereon, the ramp having a curved edge along a periphery of the face and two sides, each of the two sides extending from opposite ends of the curved edge and converging at a location along the face, the face having a chamfer along a peripheral edge thereof; and
 - a ridge between the chamfer and the location, each of the pair of side regions positioned on opposite sides of the ridge and extending between the periphery, the ridge, and one of the two sides of the ramp whereby the chamfer engages a wall of the wellbore and extrudate is drawn along the pair of side regions.
2. The cutting element of Claim 1, wherein the element body comprises a substrate.
3. The cutting element of Claim 1, wherein the element body comprises a diamond layer, the face positioned along a surface of the diamond layer.
4. The cutting element of Claim 1, wherein a ramp angle is defined between the sides of the ramp.
5. The cutting element of Claim 4, wherein the ramp angle is 60 to 90 degrees.
6. The cutting element of Claim 1, wherein a surface angle is defined along the side regions between the ridge and the one of the two sides of the ramp.
7. The cutting element of Claim 7, wherein the surface angle is 135 degrees.
8. The cutting element of Claim 1, wherein a chamfer angle is defined between a horizontal line and a face of the chamfer.
9. The cutting element of Claim 10, wherein the side angle is 45 degrees.
10. The cutting element of Claim 1, wherein the ramp and the sides incline along the periphery.
11. The cutting element of Claim 10, wherein the ramp and the side regions incline at an angle of 10 degrees.

12. The cutting element of Claim 1, wherein at least one of the ramp and the side regions are flat.
13. The cutting element of Claim 1, wherein at least one of the ramp and the side regions have a curved surface.
14. The cutting element of Claim 1, wherein the location is positioned about a center of the face.
15. The cutting element of Claim 1, wherein the location is positioned a distance from a center of the face.
16. The cutting element of Claim 1, wherein the sides are along a radius of the face.
17. The cutting element of Claim 1, wherein the ridge is along a radius of the face.
18. The cutting element of Claim 1, wherein the ridge has a width of 0.40 mm.
19. The cutting element of Claim 1, wherein the ridge has a height of 0.30 mm.
20. The cutting element of Claim 1, wherein the ridge has a length $1/2$ of a diameter of the face.
21. The cutting element of Claim 1, wherein the ridge has a length less than $1/2$ of a diameter of the face.
22. The cutting element of Claim 1, wherein the ridge has a width that narrows away from a center of the face.
23. The cutting element of Claim 1, wherein the ridge has a width that widens away from a center of the face.
24. The cutting element of Claim 1, wherein the chamfer extends along the periphery between 10 and 360 degrees of the periphery of the face.
25. The cutting element of Claim 1, wherein the chamfer defines a leading edge of the cutting element for engagement with a wall of the wellbore.
26. The cutting element of Claim 1, wherein a bottom of the element body opposite the face has a bevel.

27. A drill bit advanceable into a subterranean formation to form a wellbore, the drill bit comprising:

a bit body; and

at least one cutting element disposable in the bit body, the at least one cutting element comprising:

an element body having a face at an end thereof, the face having a ramp and a pair of side regions thereon, the ramp having a curved edge along a periphery of the face and two sides, each of the two sides extending from opposite ends of the curved edge and converging at a location along the face, the face having a chamfer along a peripheral edge thereof; and

a ridge between the chamfer and the location, each of the pair of side regions positioned on opposite sides of the ridge and extending between the periphery, the ridge, and one of the two sides of the ramp whereby the chamfer engages a wall of the wellbore and extrudate is drawn along the pair of side regions.

28. The drill bit of Claim 27, wherein the bit body has blades extending radially therefrom.

29. The drill bit of Claim 27, wherein the bit body has at least one socket to receive the at least one cutting element therein.

30. A method of advancing a drill bit advanceable into a subterranean formation to form a wellbore, the method comprising:

providing the drill bit with at least one cutting element comprising:

an element body having a face at an end thereof, the face having a ramp and a pair of side regions thereon, the ramp having a curved edge along a periphery of the face and two sides, each of the two sides extending from opposite ends of the curved edge and converging at a location along the face, the face having a chamfer along a peripheral edge thereof; and

a ridge between the chamfer and the location, each of the pair of side regions positioned on opposite sides of the ridge and extending between the periphery, the ridge, and one of the two sides of the ramp; and

engaging the chamfer of the drill bit with a wall of the wellbore.

31. The method of Claim 30, further comprising drawing extrudate from the wall of the wellbore down the pair of side regions.

32. The method of Claim 30, further comprising flowing fluid down the ramp and toward the chamfer.

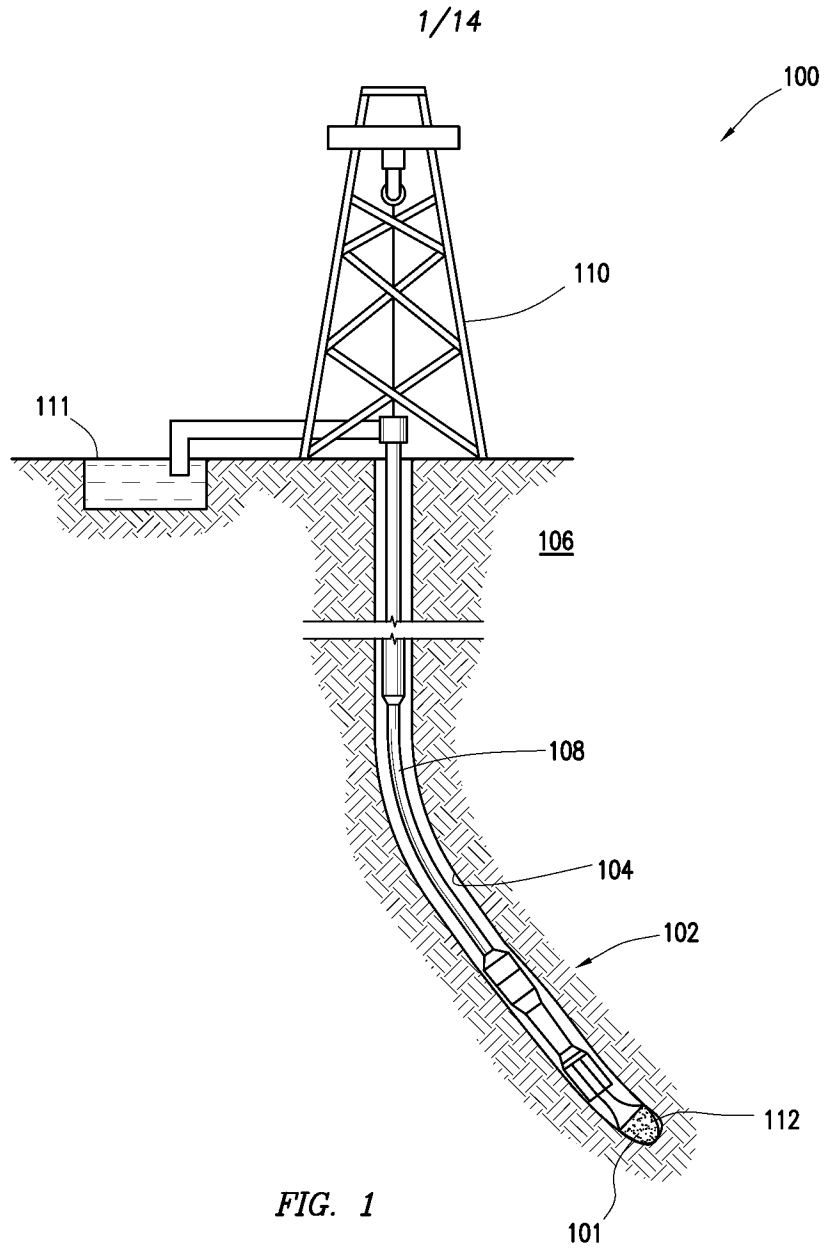

2/14

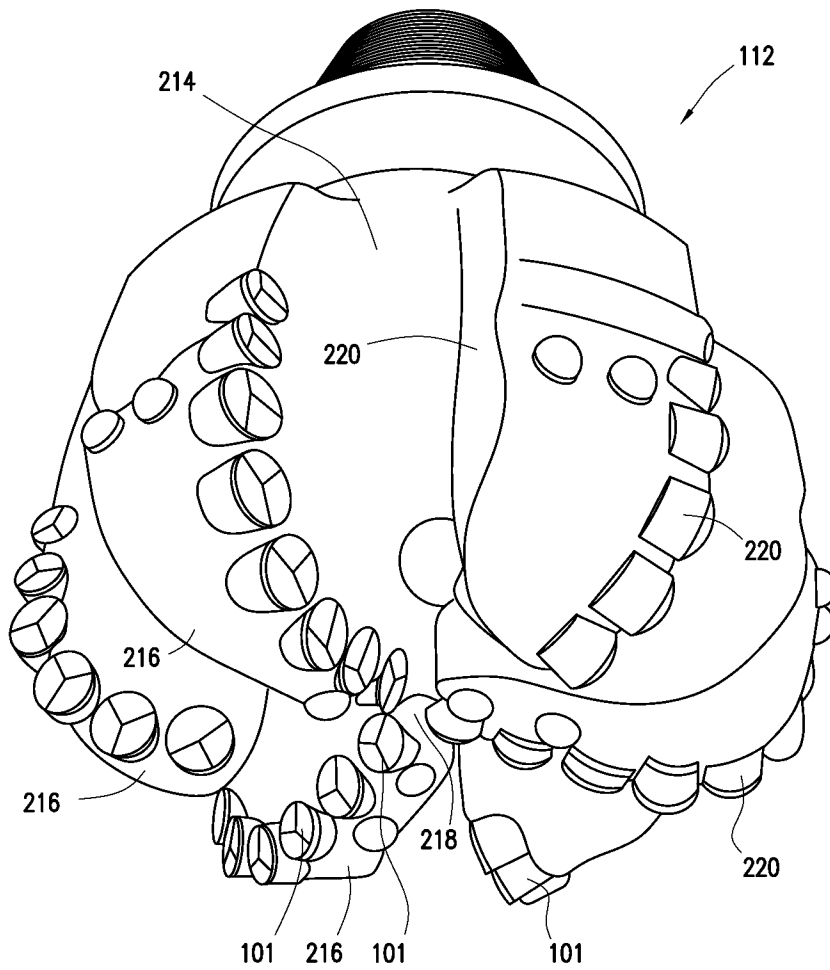

FIG. 2A

3/14

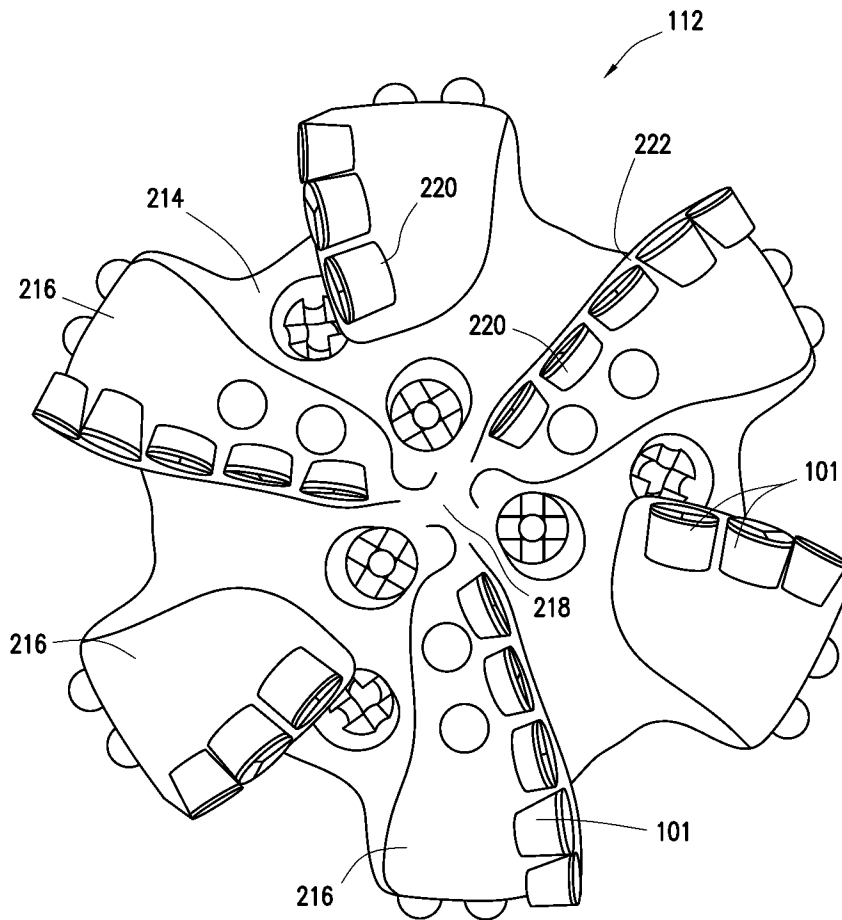

FIG. 2B

4/14

FIG. 3A

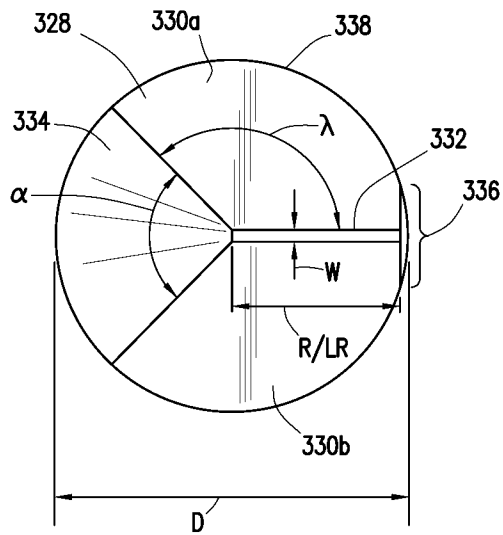
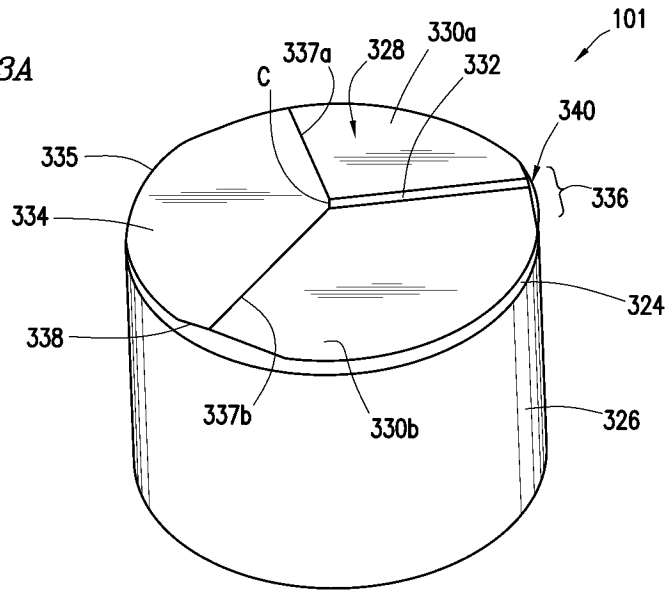

FIG. 3B

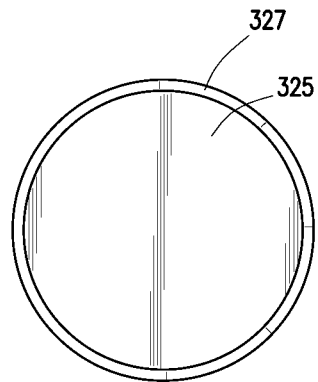

FIG. 3C

5/14

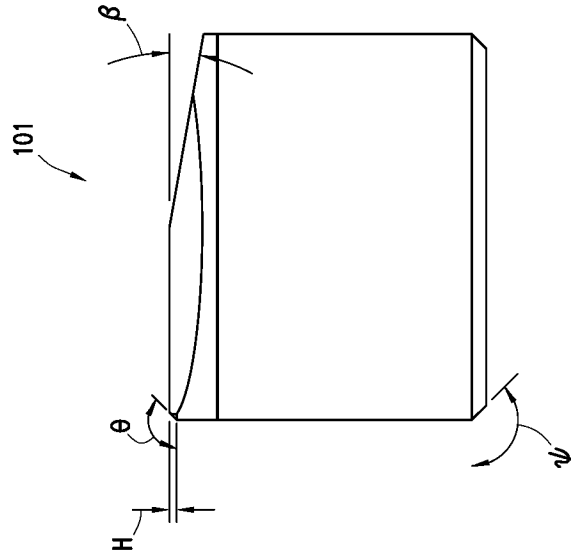

FIG. 3E

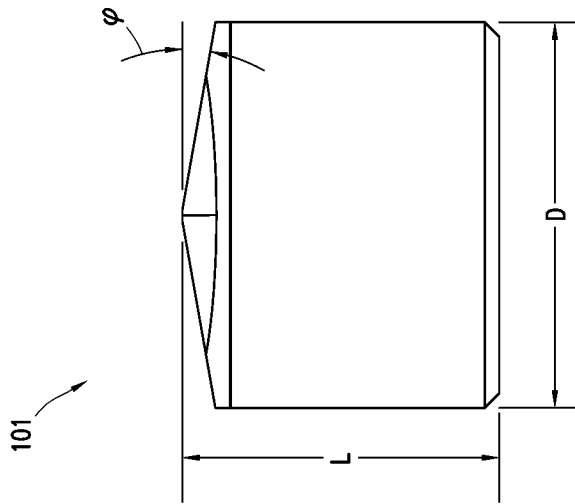

FIG. 3D

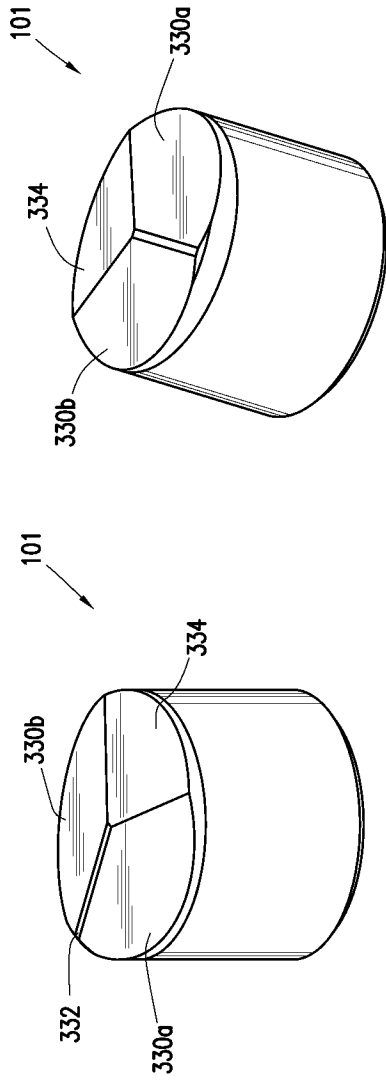

FIG. 4A

FIG. 4B

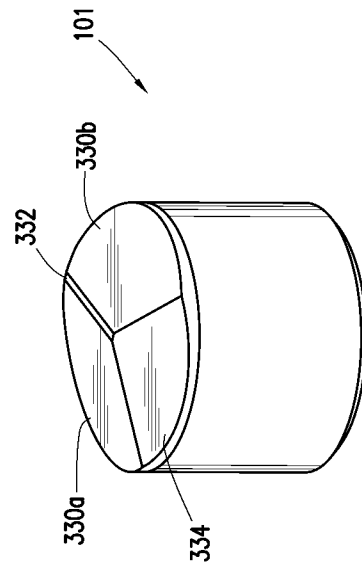

FIG. 4C

7/14

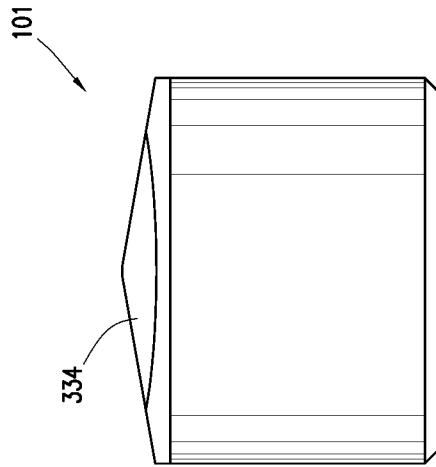

FIG. 4E

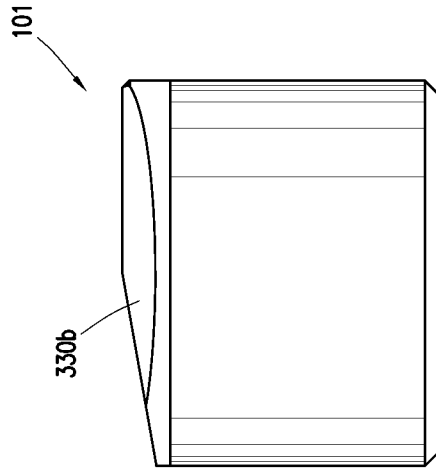

FIG. 4D

8/14

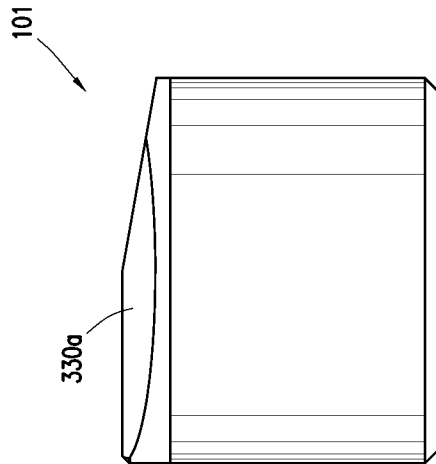

FIG. 4G

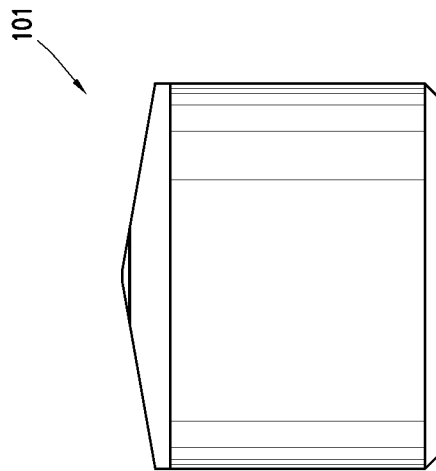

FIG. 4F

9/14

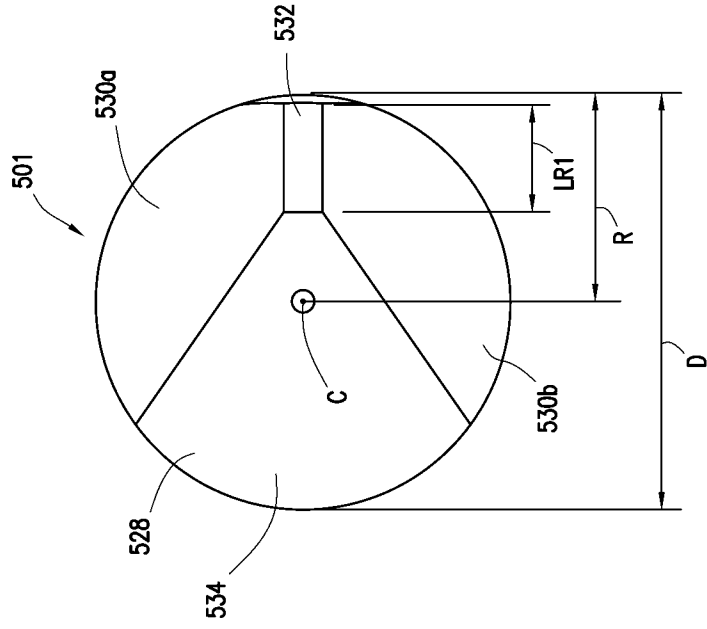

FIG. 5B

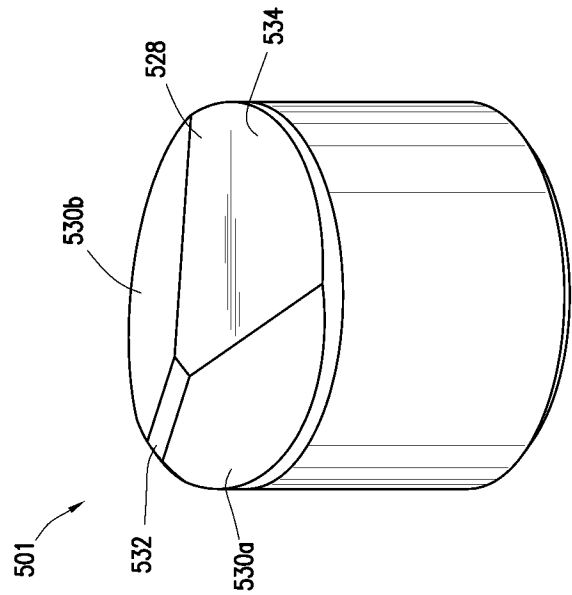

FIG. 5A

10/14

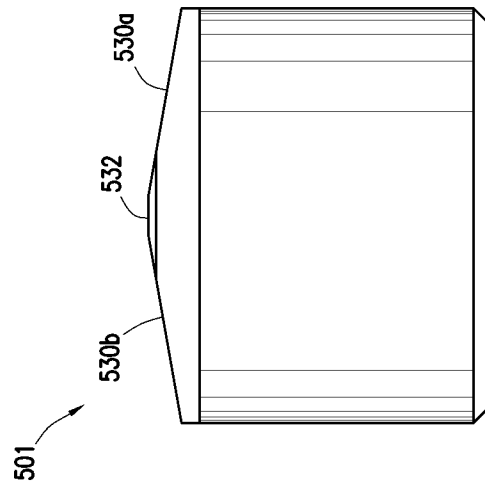

FIG. 5D

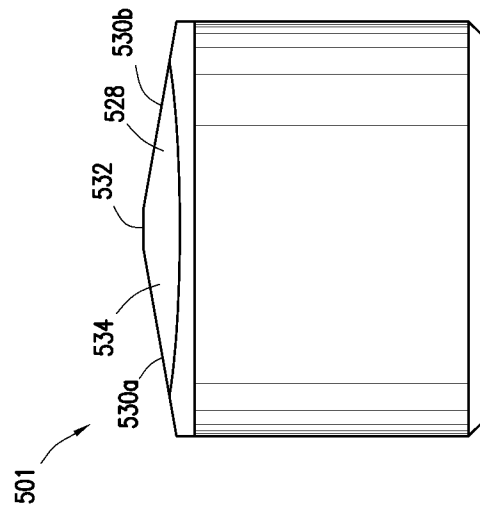

FIG. 5C

11/14

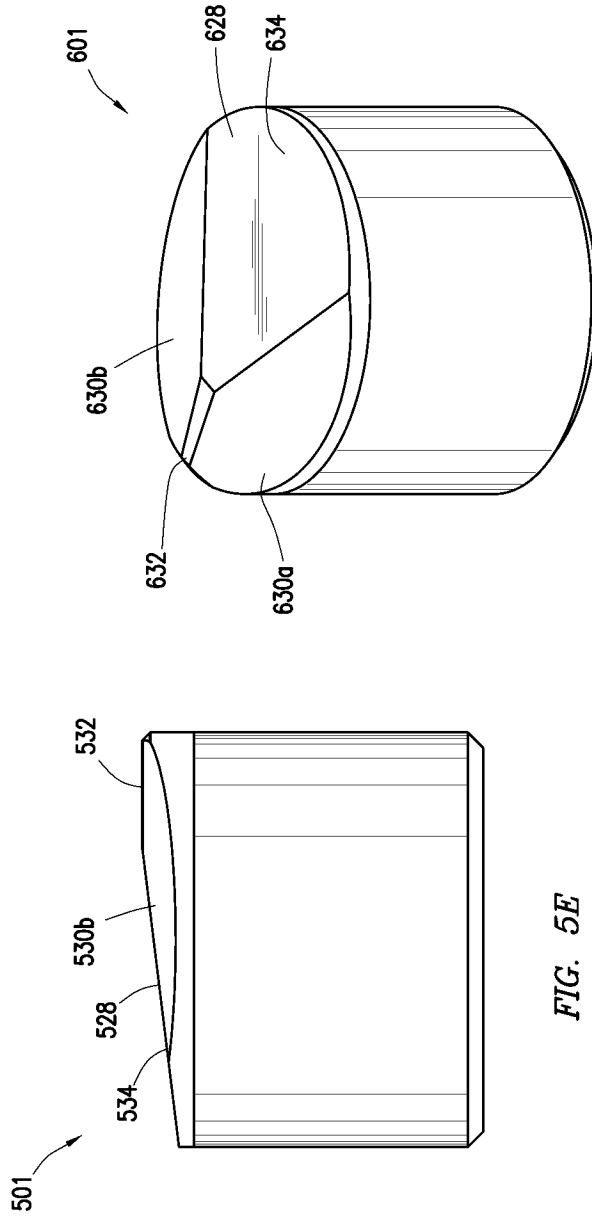

FIG. 6A

FIG. 5E

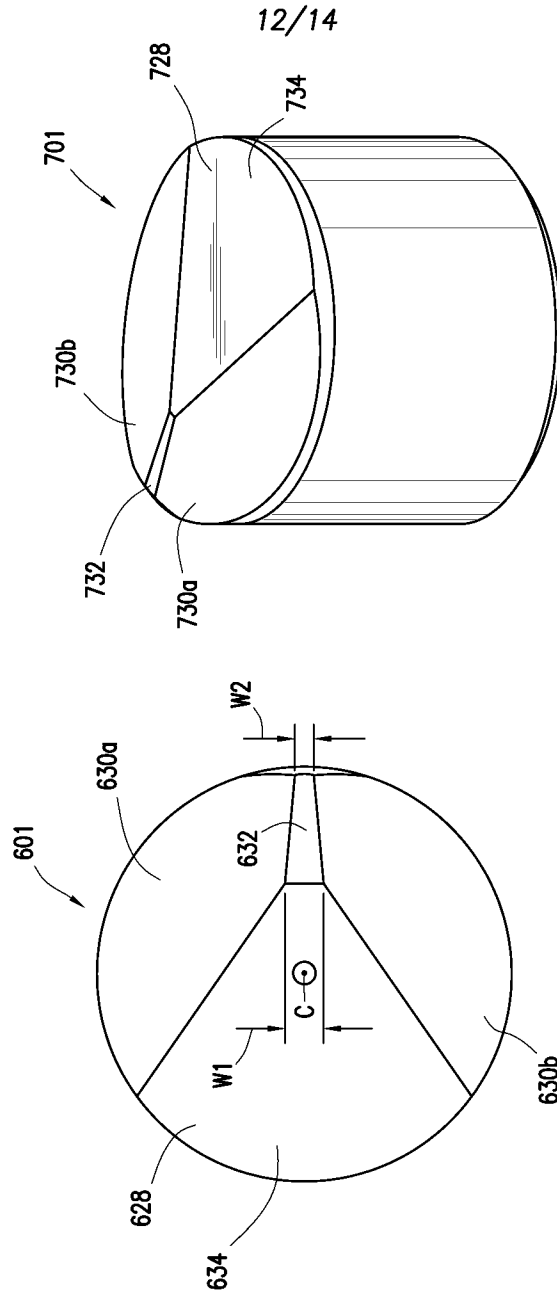

FIG. 7A

FIG. 6B

13/14

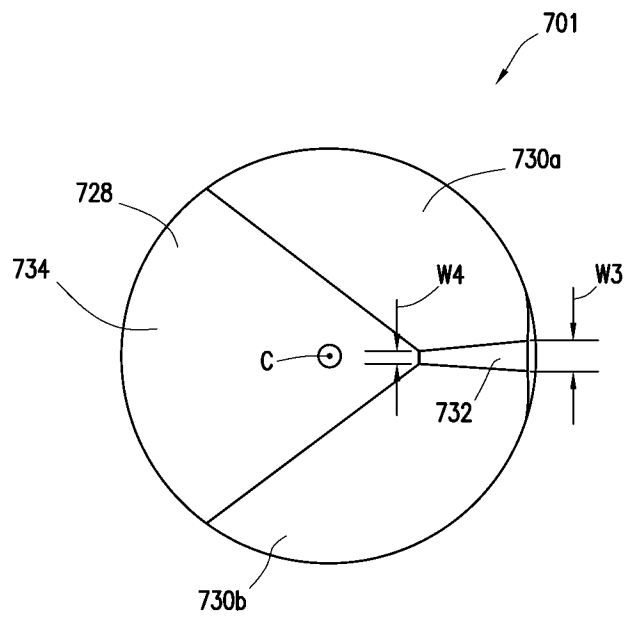

FIG. 7B

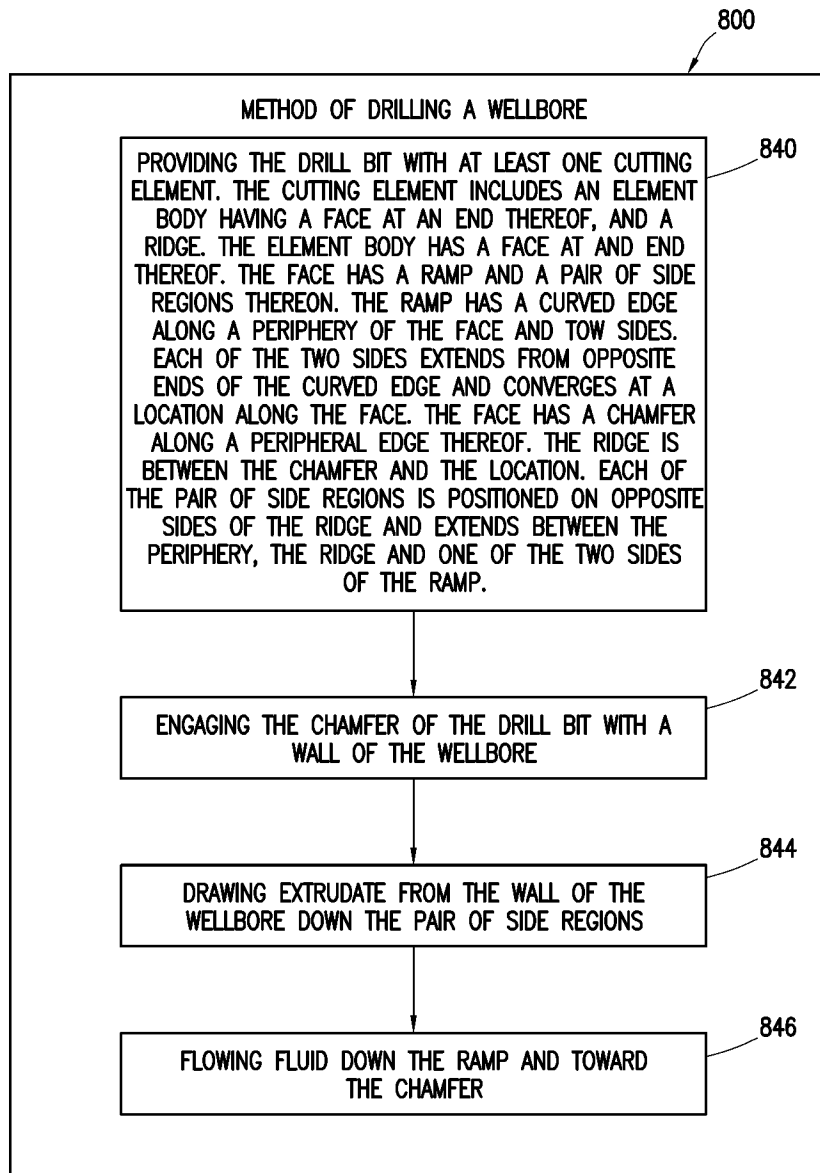

FIG. 8