

(12) UK Patent Application (11) GB (11) 2 304 504 (13) A

(43) Date of A Publication 19.03.1997

(21) Application No 9517034.6

(22) Date of Filing 19.08.1995

(71) Applicant(s)
Northern Telecom Limited

(Incorporated in Canada - Quebec)

**World Trade Center of Montreal,
380 St Antoine Street West, 8th Floor, Montreal,
Quebec H2Y 3Y4, Canada**

(72) Inventor(s)
**Leslie Derek Humphrey
Christopher N Tate**

(74) Agent and/or Address for Service
**Nortel Patents
London Road, HARLOW, Essex, CM17 9NA,
United Kingdom**

(51) INT CL⁶
H04L 5/06 , H04J 11/00

(52) UK CL (Edition O)
H4P PAQ

(56) Documents Cited
**EP 0668679 A2 EP 0668678 A2 EP 0656705 A2
US 4884139 A**

(58) Field of Search
**UK CL (Edition N) H4P PAQ
INT CL⁶ H04J 11/00 , H04L 5/06 5/22 5/26 23/02
27/148
Online: WPI, Claims, JAPIO, Inspec.**

(54) OFDM receiver includes digital filter

(57) An orthogonal frequency division multiplex (OFDM) system, e.g. for a telephone subscriber twisted pair loop, includes a transmitter for generating sets of time division samples in respective channels corresponding to an input data sequence comprising a series of bits, and a receiver coupled to the transmitter via the transmission path. The receiver incorporates a time variant digital filter 35 having a plurality of elements one for each said channel, and Fourier transform means 352 for recovering the data stream from the outputs of said filter elements. The time variant digital filter comprises a set of wavelet filters one for each transmission channel and whose tap weights are determined so as to provide specific interference rejection.

Fig.2.

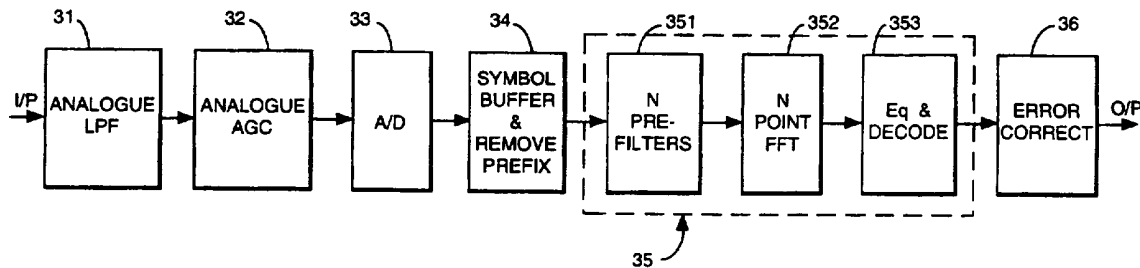

GB 2 304 504 A

Fig.1.

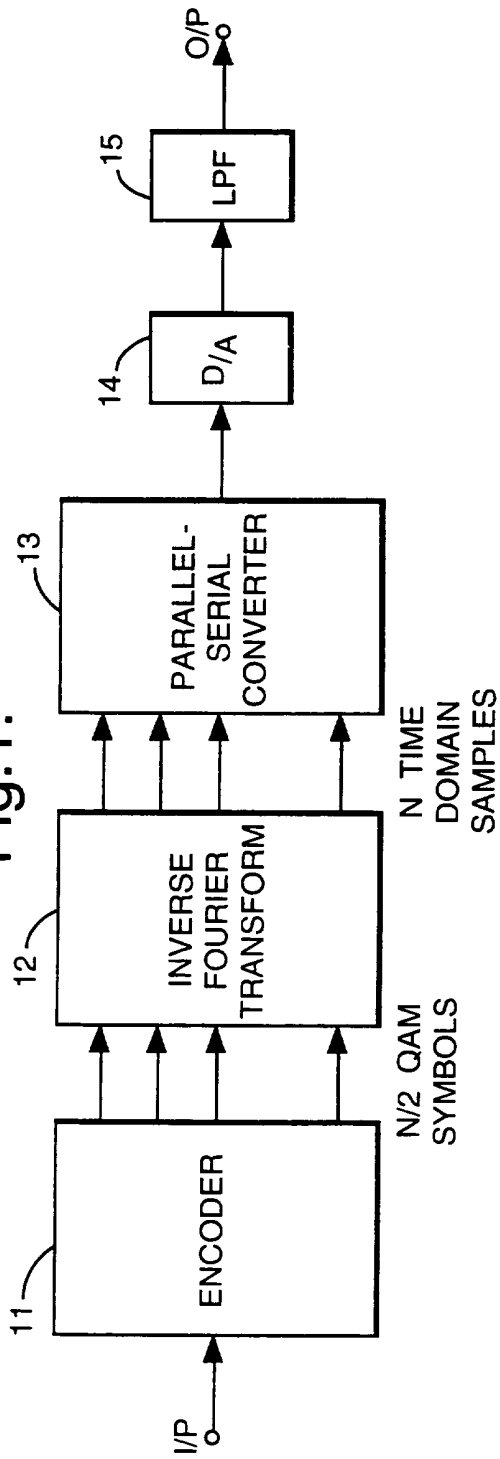

Fig.2.

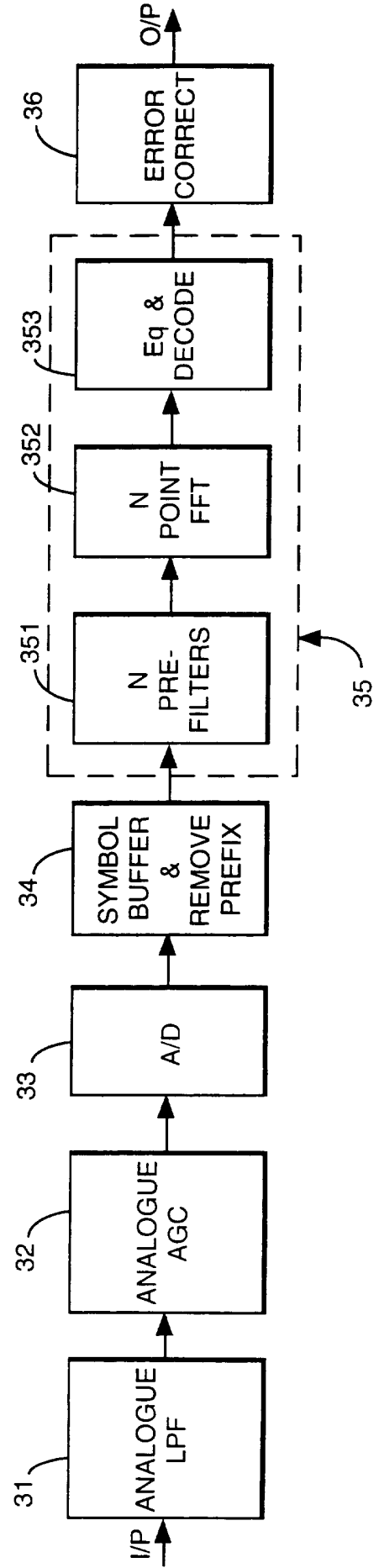

Fig.3.

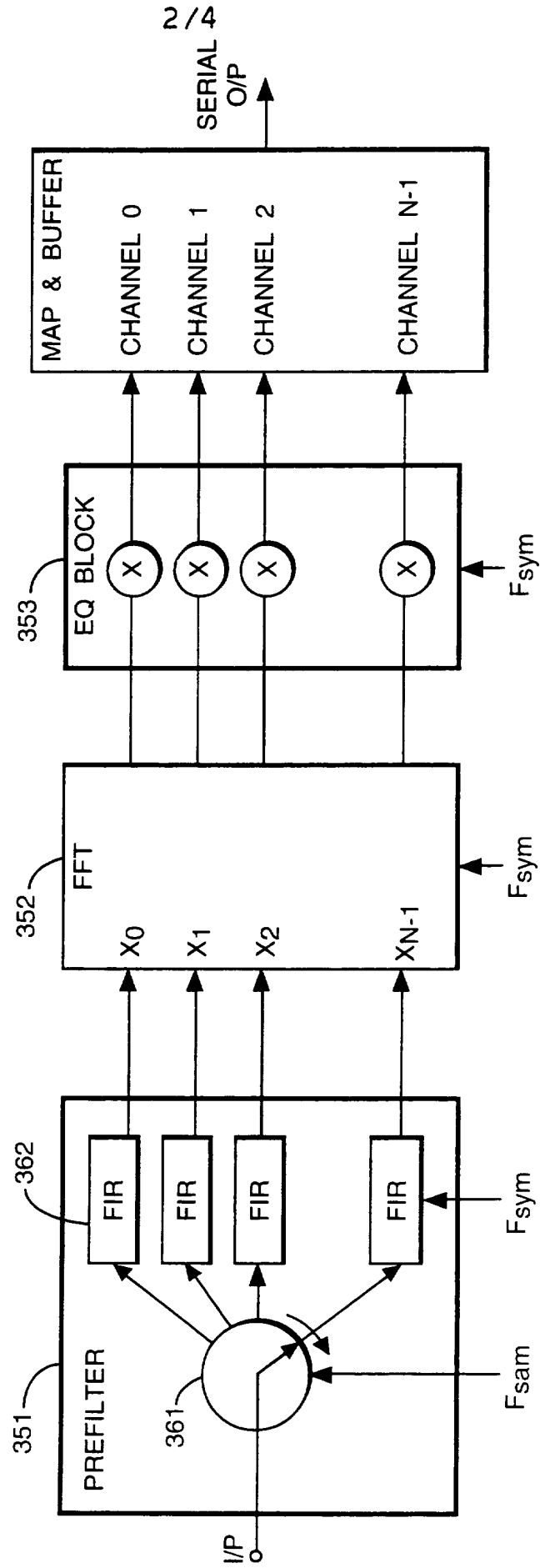

Fig.4.

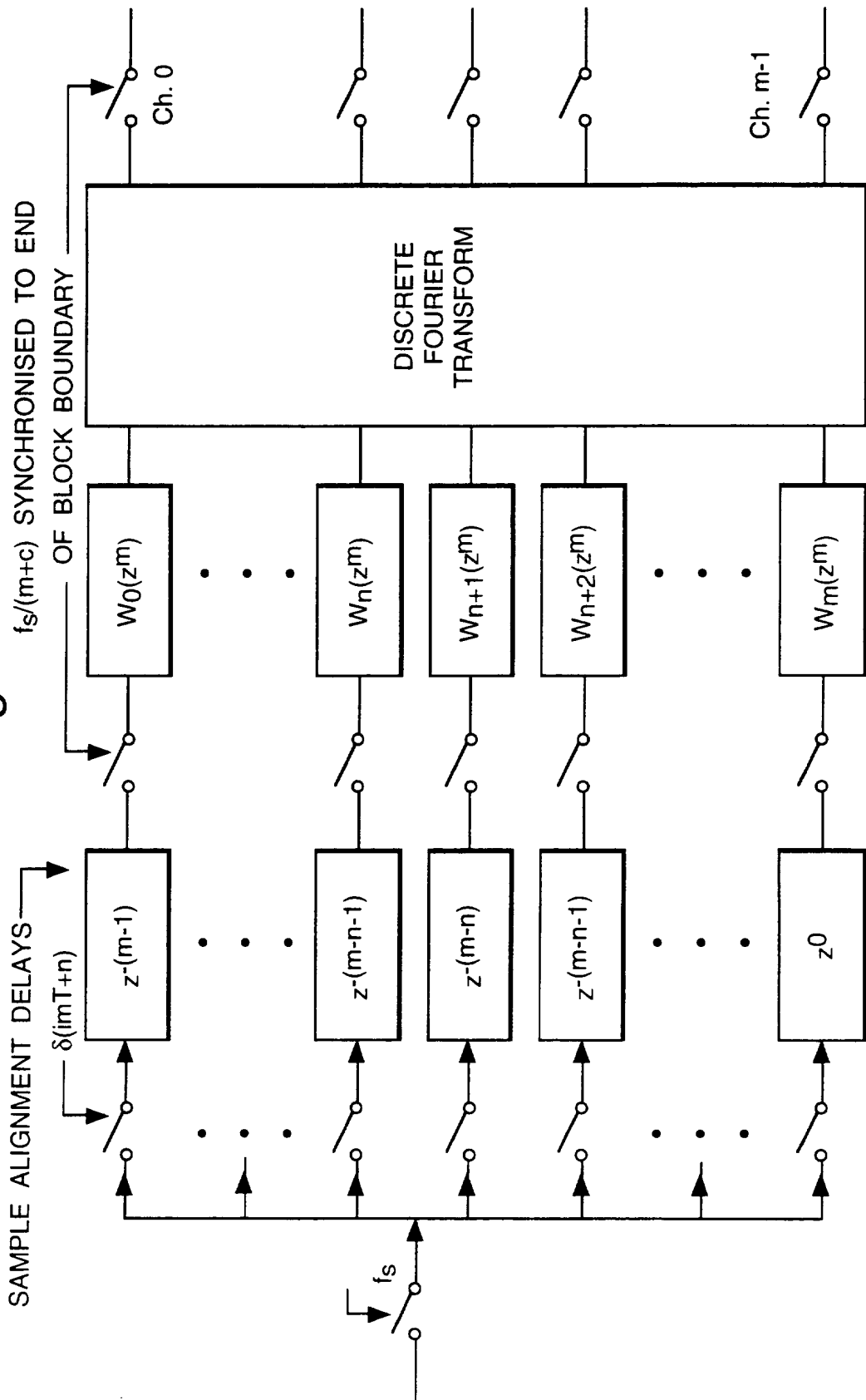

Fig.5.

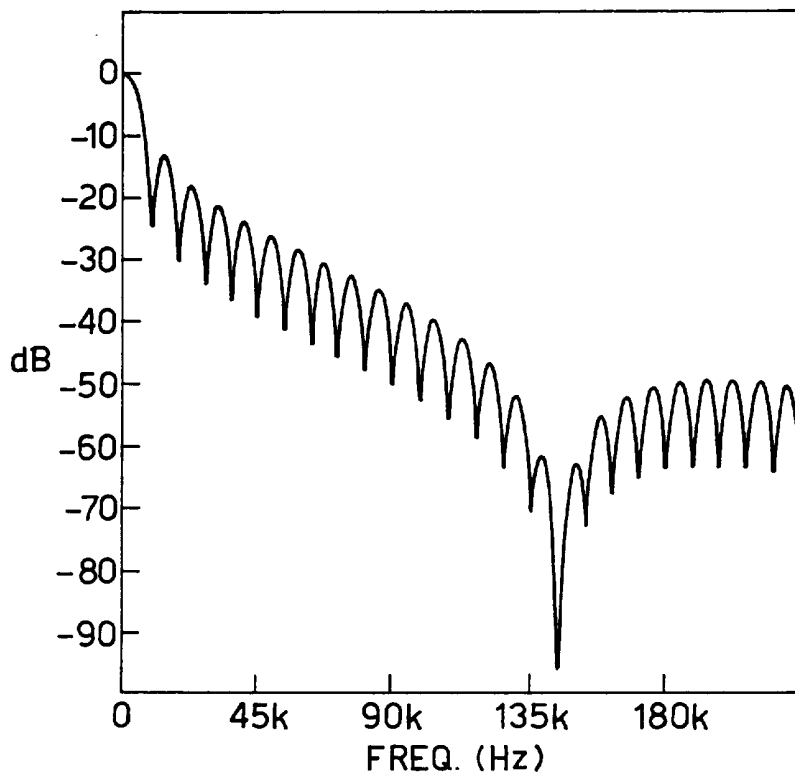
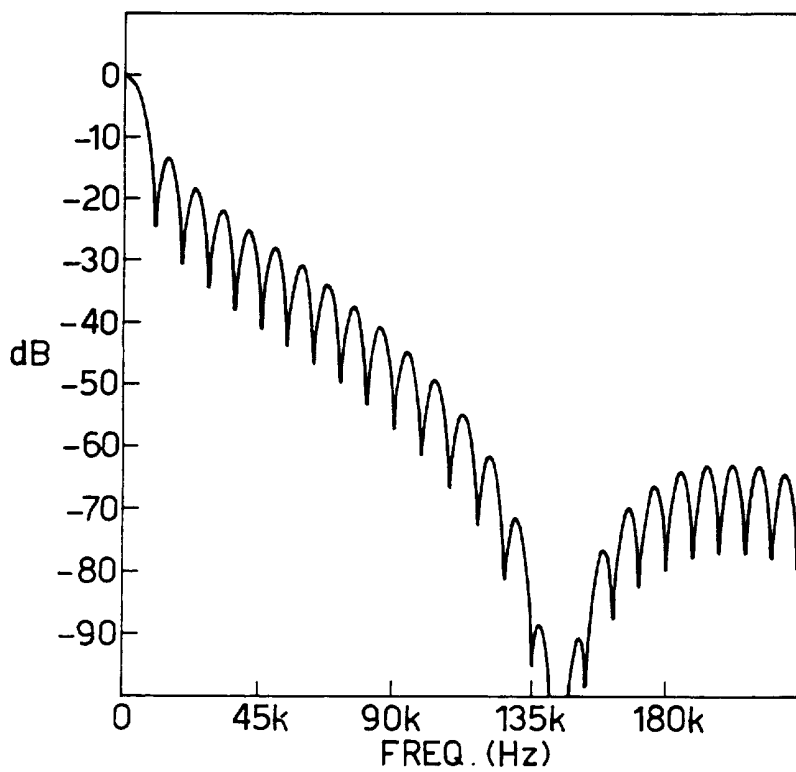

Fig.6.



2304504

DIGITAL TRANSMISSION SYSTEM

This invention relates to telecommunications systems and in particular to an arrangement and method for transmitting signals over a subscriber loop.

- 5 Telecommunication networks were originally developed to provide voice communications between subscriber terminals. With the experience of such networks from the traditional telephone or POTS service into the provision of a variety of digital series, there is now a need to provide improved subscriber access to the network. Traditionally subscribers
- 10 are coupled to the network with a twisted pair wire loop commonly referred to as the subscriber loop. The costs of replacing these loops with more efficient or higher bandwidth connections, e.g. a coaxial connection, is prohibitive and various techniques have therefore been proposed for providing effective digital across over the subscriber loop.
- 15 A recently introduced transmission technique is the orthogonal frequency division multiplex (OFDM) protocol. This technique comprises a multi-carrier modulation scheme which achieves a very low co-channel interference over dispersive channels by the use of a cyclic prefix on each data symbol. In contrast to conventional frequency division
- 20 multiplex (FDM) techniques, no complex time division equalisation is required. A description of this technique is given by J Bingham in IEEE Communications Magazine 28(4) pp 5-14 - April 1990 and by A Peled and A Ruiz in 'International Conference on Acoustics, Speech and Signal Processing' April 1980, Denver, pp964 to 967.

Orthogonal frequency division multiplex is ideally suited to digital application, and has been implemented using standard first Fourier transform (FFT) techniques. However, the application of this technique to telecommunications subscriber loop technology has been restricted
5 by its susceptibility to high level tone interference. In such circumstances, the rejection offered by conventional FFT processing has been found insufficient to prevent significant data corruption.

The object of the invention is to minimise or to overcome this
10 disadvantage.

According to one aspect of the invention there is provided an orthogonal frequency division multiplex (OFDM) receiver including a digital channel filter comprising a time variant filter structure having OFDM parameters
15 so as to provide specific interference rejection.

According to another aspect of the invention there is provided an orthogonal frequency division multiplex (OFDM) transmission system, including a transmitter adapted to generate a time modulated signal
20 corresponding to an input bit stream, and a receiver incorporating a time variant digital filter comprising a set of wavelet filters one for each transmission channel and whose tap weights are determined so as to provide specific interference rejection.

25 According to a further aspect of the invention there is provided a method of transmitting a digital data sequence comprising a series of bits over a transmission path, the method including generating sets of time division samples in respective channels corresponding to the input data sequence, transmitting said samples over the transmission path to a
30 receiver incorporating a time variant digital filter having a plurality of elements one for each said channel, and determining a Fourier transform of the outputs of the filter elements whereby to recover the data stream, wherein the time variant digital filter comprises a set of wavelet filters one for each transmission channel and whose tap weights
35 are determined so as to provide specific interference rejection.

The arrangement provides a means of digital transmission, e.g. over a telephone subscriber twisted pair loop, using a block orthogonal coding scheme. In particular it relates to a transmission coding scheme using a set of basis vectors generated by an inverse discrete Fourier transform (IFFT) in which cyclic extension of the signal block is effected by samples inserted before or after the coded symbol. The receiver employed in the arrangement uses a discrete Fourier transform (DFT) to implement a correlating detector. In this receiver, the use of a time varying digital filter before the Fourier transform provides a significant reduction in susceptibility to non-coherent interference.

An embodiment of the invention will now be described with reference to the accompanying drawings in which:-

Figure 1 is a schematic diagram of an OFDM transmitter;

Figure 2 is a block schematic diagram of an OFDM receiver according to the invention;

Figure 3 shows the detail of a digital filter arrangement for use with the receiver of figure 3;

Figure 4 shows further detail of the filter arrangement of figure 3;

Figure 5 illustrates the interference rejection achieved by the filter arrangement of figure 4 using a single stage rectangular impulse response; and

Figure 6 illustrates the interference rejection achieved by the filter arrangement of figure 4 using a dual stage cascaded rectangular impulse response.

Referring to figure 1 which shows an OFDM transmitter, an input digital serial bit stream having a bit rate of D bits per second (b/s) is buffered by an input buffer 11 into $N/2$ parallel data blocks each block comprising a number bits allocated on the basis of the respective channel signal to

noise ratio. Thus more bits will be allocated to quieter channels and vice versa. The number of data bits per block may be allocated from a predetermined knowledge of the characteristics of the transmission channel or the number may be set during start up initialisation via an automatic rate negotiation process between the two ends of the transmission link. This involves sounding the transmission link to establish the signal to noise ratio for each of the complex exponentials in the set. Advantageously the number N of data blocks is a power of two. Each set of $N/2$ data blocks is encoded as a corresponding set of $N/2$ quadrature amplitude modulation (QAM) subsymbols whose phase and amplitude represent the respective data blocks. The information in each block of B_i bits is mapped on to a set of mutually orthogonal carriers such that the B_i bits are encoded by complex amplitude modulation representing a set of allowed amplitude and phase points for each carrier. The transmitter signal is constructed by performing a sequence of inverse discrete Fourier transforms (IFFT 12) whereby the amplitude of each complex exponential is selected from the allowed set by the B_i bits allocated to the carrier C_i . The continuous stream of complex data samples may be frequency shifted and converted to a real data stream by two path I and Q channel signal processing.

In order to preserve the orthogonal nature of the carriers when the channel is subject to dispersion, we insert extra signal samples (cyclic prepended extension samples) at the start of each transform output block so that the transformed data set is prepended with a block or prefix of P samples. This extends the orthogonality over a period of greater length than the transform window and allows some degree of offset between the ideal and actual receive synchronisation and also allows the symbol boundary disturbance to decay to an insignificant level before the received signal is sampled.

The output of the inverse fast Fourier transform (IFFT) device 12 comprising a set of $N+P$ real time division samples, where P represents the added prefix, is fed via a parallel to serial converter 13 to a digital to analogue (D/A) converter 14 and a low pass filter 15 for transmission to a receiver. The sampling rate of the D/A converter is greater than the

sampling rate of the encoder 11 to allow for the added prefixes. Typically, the transmission path includes a twisted pair telephone subscriber loop.

5 Referring now to figure 2 which depicts in schematic form an OFDM receiver according to the invention, received OFDM signals are passed through an analogue low pass filter 31 and an analogue AGC circuit 32 to an analogue to digital converter 33. The resulting digital signal is fed
10 via a prefix removal stage 34 to a time variant OFDM filter 35 where the original data channels are reconstituted. These parallel channels are then output via an error detection circuit 36. The receiver provides enhanced rejection of interference by implementing a separate wavelet shaping filter for each channel. The impulse response of this filter is short in comparison with the Fourier transform order so that significant
15 attenuation is obtained while requiring the insertion of only a modest number of cyclic prepended extension samples.

Figure 3 and 4 show the time variant filter assembly 35 of figure 2 in further detail. As shown in figure 3, the filter assembly includes a pre-
20 filter 351 wherein input samples are fed selectively into a commutator 361 to each one of an array of taps 362. The commutator 361 is operated at the sampling rate F_{sam} and the taps are operated at the symbol rate F_{sym} . The relationship between the sample rate and the symbol rate is given by the expression

25

$$F_{sym} = F_{sam}/(N + P)$$

where N is the number of channels and P is the cyclic prefix. Use of a power of two block size allows a highly efficient implementation based
30 on a fast Fourier transform. A cyclic prepended extension of about 12.5% provides a trade off which yields significant benefit in reducing susceptibility to interference at a relatively modest cost in bandwidth.

Figure 4 shows the prefilter in further detail. This comprises a first order filter having the characteristic,

$$H_n = \sum_{i=0 \dots (P-1)} \Omega^{i \cdot n} z^{-i} \quad \text{where } \Omega = e^{2\pi j/m}$$

5

The architecture shown in figure 4 implements this filter as a time variant filter at the input to the Fourier transform. This provides a multichannel implementation of the OFDM receiver with shared filter architecture comprising multiple wavelet shaping filters $f=H_n(z)$.

10

The following definitions apply to this filter architecture

$$G(z) = (1 - z^{-n}) / (1 - z^{-1})$$

m = Fourier block length

c = cyclic extension length

15

$$\Omega^m = -1 \quad \Omega = e^{2\pi j/m}$$

$$H'(z) = (\sum_{i=0 \dots (p-1)} h_i z^{-i}) \times G(z) = \sum_{i=0 \dots (p+m-2)} h'_i z^{-i}$$

$$W_n(z^m) = \sum_{(\text{valid } i)} h'_{(m \cdot i - n)} z^{-mi}$$

20

$\delta(t)$ = dirac pulse at time t

$$T = m/f_s$$

Alternatively, the filter can be viewed as a set of separate time invariant filters for the individual Fourier transform inputs where the tap weights are obtained from $H_0(z)$ by sampling its tap weights over a period equal to the Fourier transform order. Where P is small, most of the subfilters default to a single tap with unity coefficients except for the first P inputs of the transform.

30

In the arrangement of figures 3 and 4, a filter response is defined which represents the response of a non-decimating channel 0 (i.e. zero freq.) OFDM receiver. The response for other OFDM channels is simply a frequency shifted version of this basic response. In the case of the conventional OFDM receiver this would simply be the Fourier transform of the rectangular FFT window. The response for the improved rejection

35

OFDM receiver of figures 3 and 4 described here is the product of the prototype responses of the conventional OFDM receiver and the chosen pre-filter. Hence, the impulse response is the convolution of the rectangular FFT window and the pre-filter impulse response.

5

Our improved OFDM system employing an N point DFT/FFT and a time variant pre-filter with an impulse response of M samples gives a composite prototype impulse response of length $L=(N+M-1)$ samples. Since only a single transform is required per symbol, a decimation factor equal to the symbol length, $N+P$, allows a considerable complexity saving in the implemented pre-filter. Each pre-filter (one per FFT bin) is operated at the decimated rate and has coefficients determined by sub-sampling the overall prototype filter impulse response. A section of an N channel OFDM receiver is shown using N pre-filters with $(L/N)+1$ taps each and a single N point FFT. In this system, the pre-filters and the FFT operate at the $F_{\text{sam}}/(N + P)$ and produce down-sampled outputs for each channel in parallel. The impulse response of the pre-filter should ideally be short in comparison with the transform length in order that the prefix size can be minimised with respect to the symbol length. Excepting this, the precise pre-filter response is arbitrary provided that it has the desired spectral characteristics. In order to simplify the modified OFDM implementation, the pre-filter can be chosen to have an impulse response which minimises the multiplication hardware requirement. The choice of a rectangular shape for the pre-filter response delivers coefficients which can be represented with low precision binary words saving both storage and multiplication hardware. Other pre-filter responses based on cascaded rectangular impulse responses can also be used to give greater interference rejection albeit at some increase in complexity.

30

In circumstances where large interferer signals are spaced in a regular fashion across the OFDM spectrum (e.g. in broadcast radio pick-up where carriers are allocated on a fixed frequency spacing) it is possible to arrange for the OFDM modulation system (and the pre-filter) to have 'notches' of high attenuation at the relevant frequencies. This involves

35

appropriate selection of the OFDM parameters and the pre-filter response.

5 For example, a system based on a symbol rate, F_{sym} , of 8kHz and an OFDM carrier spacing, F_{car} , of 9kHz has been investigated. This system employed a sampling rate, F_{sam} , of 2.304MHz and a FFT size, N , of 256 points giving a cyclic prefix, P , of 32 samples. This provided a 9kHz carrier spacing which suits the rejection of medium wave AM
10 broadcasts. Several pre-filter options based on rectangular impulse responses were also investigated: a single 16 tap, a dual cascaded 16 tap, and a cascade of a 16 tap and a 12 tap. Figure 5 shows the response of the receiver (for the OFDM carrier at DC) to interference for a single 16 tap pre-filter and Figure 6 shows equivalent results for a dual cascaded 16 tap pre-filter.

15 The OFDM technique described above can be extended to implement multi-point to point communication thus allowing a number of transmitters to share the bandwidth of one receiver. This may be achieved by allocating one carrier to each transmitter, avoiding carriers
20 subject to interference. The various transmitters are controlled so as to adjust their transmission levels to substantially equalise the received signal levels thus minimising the dynamic range required for analogue to digital conversion. In a further modification, the Fourier transform block size can be increased and the transmission rate reduced to provide the
25 same transmission capacity but allocating more than one carrier to each transmitter.

CLAIMS:

1. An orthogonal frequency division multiplex (OFDM) receiver
5 including a digital channel filter comprising a time variant filter structure
having OFDM parameters so as to provide specific interference
frequency rejection.

2. An orthogonal frequency division multiplex (OFDM)
10 transmission system, including a transmitter adapted to generated a
time modulated signal corresponding to an input bit stream, and a
receiver incorporating a time variant digital filter comprising a set of
wavelet filters one for each transmission channel and whose tap weights
are determined so as to provide specific interference rejection.

15 3. An orthogonal frequency division multiplex (OFDM)
transmission system, including a transmitter having means for
generating sets of time division samples in respective channels
corresponding to an input data sequence comprising a series of bits,
20 and a receiver coupled to the transmitter via a transmission path, the
receiver incorporating a time variant digital filter and Fourier transform
means for recovering the data stream from the output of said filter, and
wherein the time variant digital filter comprises a set of wavelet filters
one for each transmission channel and whose tap weights are
25 determined so as to provide specific interference rejection.

4. A system as claimed in claim 3, wherein the transmission path
comprises a telephone subscriber loop.

30 5. A system as claimed in claim 3 or 4, wherein the transmitter
includes means for allocating bits of the data sequence to the channels
whereby a greater number of bits are allocated to those channels
subject to a low level of interference and a lesser number of bits are
allocate to those channels subject to a high level of interference.

35

6. A system as claimed in claim 3, 4 or 5, wherein the filter has an impulse response which is short in comparison with the Fourier transform order.

5 7 An orthogonal frequency division multiplex (OFDM) transmission system substantially as described herein with reference to and as shown in the accompanying drawings.

8. A method of transmitting a digital data sequence comprising a series of bits over a transmission path, the method including generating sets of time division samples in respective channels corresponding to the input data sequence, transmitting said samples over the transmission path to a receiver incorporating a time variant digital filter having a plurality of elements one for each said channel, and
10 determining a Fourier transform of the outputs of the filter elements whereby to recover the data stream, wherein the time variant digital filter comprises a set of wavelet filters one for each transmission channel and whose tap weights are determined so as to provide specific interference
15 rejection.

20

9. A method as claimed in claim 8, wherein the transmission path comprises a telephone subscriber loop.

10. A method of transmitting a digital data sequence substantially
25 as described herein with reference to and as shown in the accompanying drawings.

11

Patents Act 1977
Examiner's report to the Comptroller under Section 17
(The Search report)

Application number
 GB 9517034.6

Relevant Technical Fields

- (i) UK Cl (Ed.N) H4P PAQ
- (ii) Int Cl (Ed.6) H04L 5/06, 5/22, 5/26, 23/02,
 27/148 H04J 11/00

Search Examiner
 MR B J SPEAR

Date of completion of Search
 23 OCTOBER 1995

Databases (see below)

- (i) UK Patent Office collections of GB, EP, WO and US patent specifications.
- (ii) ONLINE: WPI, CLAIMS, JAPIO, INSPEC

Documents considered relevant following a search in respect of Claims :-
 1-10

Categories of documents

- | | |
|--|---|
| <p>X: Document indicating lack of novelty or of inventive step.</p> <p>Y: Document indicating lack of inventive step if combined with one or more other documents of the same category.</p> <p>A: Document indicating technological background and/or state of the art.</p> | <p>P: Document published on or after the declared priority date but before the filing date of the present application.</p> <p>E: Patent document published on or after, but with priority date earlier than, the filing date of the present application.</p> <p>&: Member of the same patent family; corresponding document.</p> |
|--|---|

Category	Identity of document and relevant passages	Relevant to claim(s)
X,E	EP 0668679 A2 (ITALTEL) Figure 7 and, eg page 6 lines 17-34	1-3, 8 at least
X,E	EP 0668678 A2 (ITALTEL) Figure 11 and, eg column 8 lines 15-39	1-3, 8 at least
X	EP 0656705 A2 (S.I.S.V.EL) Figure 17 and, eg page 4 lines 41-46 and page 8 lines 4-27	1-3, 8 at least
X	US 4884139 (ETAT FRANCAIS) Figure 4 and, eg column 7 line 60 to column 8 line 13	1-3, 8 at least

Databases:The UK Patent Office database comprises classified collections of GB, EP, WO and US patent specifications as outlined periodically in the Official Journal (Patents). The on-line databases considered for search are also listed periodically in the Official Journal (Patents).