



(51) International Patent Classification:
F25J 3/02 (2006.01) F25J 3/08 (2006.01)

(74) Agents: **RUSSION, Alicia A.** et al.; Fitzpatrick, Cella, Harper & Scinto, 1290 Avenue of The Americas, New York, NY 10104-3800 (US).

(21) International Application Number:
PCT/US2014/051548

(81) Designated States (unless otherwise indicated, for every kind of national protection available): AE, AG, AL, AM, AO, AT, AU, AZ, BA, BB, BG, BH, BN, BR, BW, BY, BZ, CA, CH, CL, CN, CO, CR, CU, CZ, DE, DK, DM, DO, DZ, EC, EE, EG, ES, FI, GB, GD, GE, GH, GM, GT, HN, HR, HU, ID, IL, IN, IR, IS, JP, KE, KG, KN, KP, KR, KZ, LA, LC, LK, LR, LS, LT, LU, LY, MA, MD, ME, MG, MN, MW, MX, MY, MZ, NA, NG, NI, NO, NZ, OM, PA, PE, PG, PH, PL, PT, QA, RO, RS, RU, RW, SA, SC, SD, SE, SG, SK, SL, SM, ST, SV, SY, TH, TJ, TM, TN, TR, TT, TZ, UA, UG, US, UZ, VC, VN, ZA, ZM, ZW.

(22) International Filing Date:
18 August 2014 (18.08.2014)

(25) Filing Language: English

(26) Publication Language: English

(30) Priority Data:
61/876,415 11 September 2013 (11.09.2013) US
61/879,308 18 September 2013 (18.09.2013) US
14/462,083 18 August 2014 (18.08.2014) US

(84) Designated States (unless otherwise indicated, for every kind of regional protection available): ARIPO (BW, GH, GM, KE, LR, LS, MW, MZ, NA, RW, SD, SL, SZ, TZ, UG, ZM, ZW), Eurasian (AM, AZ, BY, KG, KZ, RU, TJ, TM), European (AL, AT, BE, BG, CH, CY, CZ, DE, DK, EE, ES, FI, FR, GB, GR, HR, HU, IE, IS, IT, LT, LU, LV, MC, MK, MT, NL, NO, PL, PT, RO, RS, SE, SI, SK, SM, TR), OAPI (BF, BJ, CF, CG, CI, CM, GA, GN, GQ, GW, KM, ML, MR, NE, SN, TD, TG).

(71) Applicants: **ORTLOFF ENGINEERS, LTD.** [US/US]; 415 West Wall, Suite 2000, Midland, TX 79701 (US). **S.M.E. PRODUCTS LP** [US/US]; 6715 Theall, Houston, TX 77066 (US).

Published:
— with international search report (Art. 21(3))

(72) Inventors: **MILLER, Scott, A.**; 4101 Crestridge Drive, Midland, TX 79707 (US). **WILKINSON, John, D.**; 4113 Tanforan Avenue, Midland, TX 79707 (US). **LYNCH, Joe, T.**; 5510 Ashwood Court, Midland, TX 79707 (US). **HUDSON, Hank, M.**; 2508 W. Sinclair Avenue, Midland, TX 79705 (US). **CUELLAR, Kyle, T.**; 1611 Cottage Point, Katy, TX 77494 (US). **JOHNKE, Andrew, F.**; 907 W. Main Street, Beresford, SD 57004 (US). **LEWIS, W., Larry**; 17127 Lakeway Park, Tomball, TX 77375 (US).

(54) Title: HYDROCARBON GAS PROCESSING

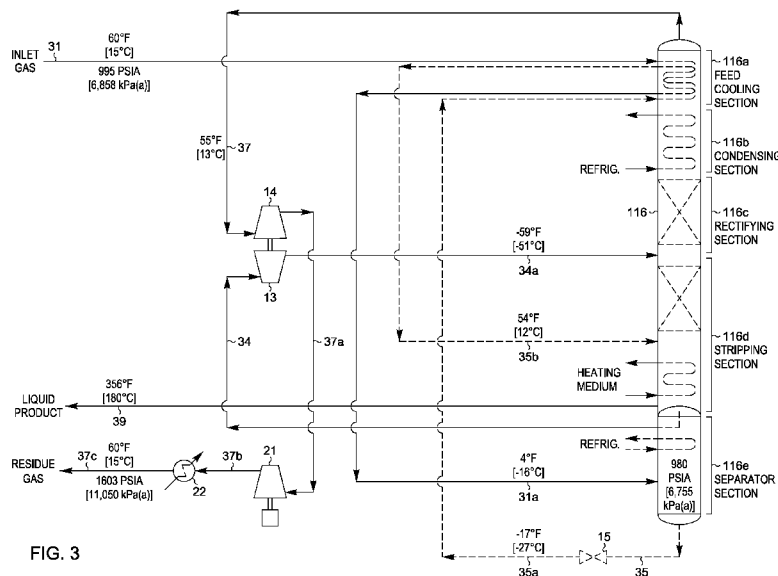

FIG. 3

(57) Abstract: A process and an apparatus are disclosed for a compact processing assembly to remove C₅ and heavier hydrocarbon components from a hydrocarbon gas stream. The hydrocarbon gas stream is expanded to lower pressure and supplied to the processing assembly between an absorbing means and a mass transfer means. A distillation vapor stream is collected from the upper region of the absorbing means and cooled in a first heat and mass transfer means inside the processing assembly to partially condense it, forming a residual vapor stream and a condensed stream. The condensed stream is supplied to the absorbing means at its top feed point. A distillation liquid stream is collected from the lower region of the mass transfer means and directed into a second heat and mass transfer means inside the processing assembly to heat it and strip out its volatile components.

WO 2015/038289 A1

HYDROCARBON GAS PROCESSING

SPECIFICATION

BACKGROUND OF THE INVENTION

[0001] Natural gas is typically recovered from wells drilled into underground reservoirs. It usually has a major proportion of methane, i.e., methane comprises at least 50 mole percent of the gas. Depending on the particular underground reservoir, the natural gas also contains relatively lesser amounts of heavier hydrocarbons such as ethane, propane, butanes, pentanes and the like, as well as water, hydrogen, nitrogen, carbon dioxide, and other gases. A typical analysis of a natural gas stream to be processed in accordance with this invention would be, in approximate mole percent, 89.2% methane, 4.9% ethane and other C₂ components, 2.6% propane

and other C₃ components, 0.4% iso-butane, 1.3% normal butane, and 0.6% pentanes plus, with the balance made up of nitrogen and carbon dioxide. Sulfur containing gases are also sometimes present.

[0002] Most natural gas is handled in gaseous form. The most common means for transporting natural gas from the wellhead to gas processing plants and thence to the natural gas consumers is in high-pressure gas transmission pipelines. In a number of circumstances, however, it has been found necessary and/or desirable to liquefy the natural gas either for transport or for use. In remote locations, for instance, there is often no pipeline infrastructure that would allow for convenient transportation of the natural gas to market. In such cases, the much lower specific volume of liquefied natural gas (LNG) relative to natural gas in the gaseous state can greatly reduce transportation costs by allowing delivery of the LNG using cargo ships and transport trucks.

[0003] A relatively recent concept for commercializing natural gas from remote locations is to install a liquefaction plant on an offshore platform or on a ship (commonly referred to as floating LNG or FLNG) to allow moving the facility to another location when the gas reservoir is depleted. Deck space is at a premium for both of these, because each increment of deck space requires a very large quantity of supporting structure (and hull volume in the case of FLNG). As a result, great emphasis is placed on minimizing the "footprint" of each processing step in order to minimize the investment cost and thereby maximize the number of gas reservoirs in remote locations that can be economically produced.

[0004] For remote locations such as those contemplated here, recovery of the various hydrocarbons heavier than methane as separate products is generally not economically viable since there is usually no means of transporting and selling the resultant hydrocarbon product

streams. Instead, to the largest extent possible, these heavier hydrocarbons are liquefied along with the methane and sold as part of the LNG product. However, some degree of heavier hydrocarbon removal is often required prior to liquefying the natural gas because there are usually limitations on the heating value of the re-vaporized gas when it is subsequently distributed from the LNG receiving terminal. In addition, hydrocarbons heavier than C₅ or C₆ (particularly aromatic hydrocarbons) generally must be removed upstream of the liquefaction step to avoid plugging inside the liquefaction plant caused by freezing of these heavier hydrocarbons. For these reasons, it is typical to include a processing step to remove these hydrocarbons ("heavy ends removal") before liquefying the natural gas.

[0005] Available processes for removing these heavier hydrocarbons include those based upon cooling and refrigeration of gas, oil absorption, and refrigerated oil absorption.

Additionally, cryogenic processes have become popular because of the availability of economical equipment that produces power while simultaneously expanding and extracting heat from the gas being processed. Depending upon the pressure of the gas source, the richness (ethane, ethylene, and heavier hydrocarbons content) of the gas, and the desired end products, each of these processes or a combination thereof may be employed.

[0006] The cryogenic expansion process is now generally preferred for removing heavy hydrocarbons from natural gas because it provides maximum simplicity with ease of startup, operating flexibility, good efficiency, safety, and good reliability. U.S. Patent Nos. 3,292,380; 4,061,481; 4,140,504; 4,157,904; 4,171,964; 4,185,978; 4,251,249; 4,278,457; 4,519,824; 4,617,039; 4,687,499; 4,689,063; 4,690,702; 4,854,955; 4,869,740; 4,889,545; 5,275,005; 5,555,748; 5,566,554; 5,568,737; 5,771,712; 5,799,507; 5,881,569; 5,890,378; 5,983,664; 6,182,469; 6,578,379; 6,712,880; 6,742,358; 6,915,662; 6,945,075; 7,010,937; 7,191,617;

7,204,100; 7,210,311; 7,219,513; 7,565,815; 8,590,340; reissue U.S. Patent No. 33,408; and co-pending application nos. 11/430,412; 11/839,693; 12/206,230; 12/487,078; 12/689,616; 12/717,394; 12/750,862; 12/772,472; 12/781,259; 12/868,993; 12/869,007; 12/869,139; 12/979,563; 13/048,315; 13/051,682; 13/052,348; 13/052,575; and 13/053,792 describe relevant processes (although the description of the present invention in some cases is based on different processing conditions than those described in the cited U.S. Patents and co-pending applications).

[0007] The present invention is a novel means of removing heavier hydrocarbon components from natural gas that combines what heretofore have been individual equipment items into a common housing, thereby reducing the plot space requirements, the capital cost of the plant, and (more importantly) the capital cost of the associated platform or ship. In addition, the more compact arrangement also eliminates much of the piping used to interconnect the individual equipment items in traditional plant designs, further reducing capital cost and also eliminating the associated flanged piping connections. Since piping flanges are a potential leak source for hydrocarbons (which are volatile organic compounds, VOCs, that contribute to greenhouse gases and may also be precursors to atmospheric ozone formation), eliminating these flanges reduces the potential for atmospheric emissions that may damage the environment.

[0008] For a better understanding of the present invention, reference is made to the following examples and drawings. Referring to the drawings:

[0009] FIGS. 1 and 2 are flow diagrams of prior art heavy ends removal processes for a natural gas liquefaction plant;

[0010] FIG. 3 is a flow diagram of a heavy ends removal plant for a natural gas liquefaction plant in accordance with the present invention; and

[0011] FIGS. 4 through 6 are flow diagrams illustrating alternative means of application of the present invention to heavy ends removal from a natural gas stream.

[0012] In the following explanation of the above figures, tables are provided summarizing flow rates calculated for representative process conditions. In the tables appearing herein, the values for flow rates (in moles per hour) have been rounded to the nearest whole number for convenience. The total stream rates shown in the tables include all non-hydrocarbon components and hence are generally larger than the sum of the stream flow rates for the hydrocarbon components. Temperatures indicated are approximate values rounded to the nearest degree. It should also be noted that the process design calculations performed for the purpose of comparing the processes depicted in the figures are based on the assumption of no heat leak from (or to) the surroundings to (or from) the process. The quality of commercially available insulating materials makes this a very reasonable assumption and one that is typically made by those skilled in the art.

[0013] For convenience, process parameters are reported in both the traditional British units and in the units of the Système International d'Unités (SI). The molar flow rates given in the tables may be interpreted as either pound moles per hour or kilogram moles per hour. The energy consumptions reported as horsepower (HP) and/or thousand British Thermal Units per hour (MBTU/Hr) correspond to the stated molar flow rates in pound moles per hour. The energy consumptions reported as kilowatts (kW) correspond to the stated molar flow rates in kilogram moles per hour.

DESCRIPTION OF THE PRIOR ART

[0014] FIG. 1 is a process flow diagram showing the design of a processing plant to remove heavier hydrocarbon components from a natural gas stream using a prior art process. In this simulation of the process, inlet gas enters the plant at 60°F [15°C] and 995 psia [6,858 kPa(a)] as stream **31**. If the inlet gas contains a concentration of sulfur compounds which would prevent the product streams from meeting specifications, the sulfur compounds are removed by appropriate pretreatment of the feed gas (not illustrated). In addition, the feed stream is usually dehydrated to prevent hydrate (ice) formation under cryogenic conditions. Solid desiccant has typically been used for this purpose.

[0015] The feed stream **31** is divided into two portions, streams **32** and **33**. Stream **32** is cooled in heat exchanger **10** by heat exchange with cool residue gas stream **37**, while stream **33** is cooled in heat exchanger **11** by heat exchange with flash expanded liquids (stream **35a**). Streams **32a** and **33a** recombine to form stream **31a**, which enters separator **12** at 4°F [-16°C] and 980 psia [6,755 kPa(a)] where the vapor (stream **34**) is separated from the condensed liquid (stream **35**).

[0016] The vapor from separator **12** (stream **34**) enters a work expansion machine **13** in which mechanical energy is extracted from this portion of the high pressure feed. The machine **13** expands the vapor substantially isentropically to the operating pressure (approximately 470 psia [3,238 kPa(a)]) of fractionation tower **16**, with the work expansion cooling the expanded stream **34a** to a temperature of approximately -59°F [-51°C]. The typical commercially available expanders are capable of recovering on the order of 80-85% of the work theoretically available in an ideal isentropic expansion. The work recovered is often used to drive a centrifugal compressor (such as item **14**) that can be used to re-compress the heated

residue gas stream (stream **37a**), for example. The partially condensed expanded stream **34a** is thereafter supplied as feed to fractionation tower **16** at an upper mid-column feed point. The separator liquid (stream **35**) is expanded to slightly above the operating pressure of fractionation tower **16** by expansion valve **15**, then heated from -17°F [-27°C] to 54°F [12°C] in heat exchanger **11** as described earlier before stream **35b** is supplied to fractionation tower **16** at a lower mid-column feed point.

[0017] Fractionation tower **16** is a conventional distillation column containing a plurality of vertically spaced trays, one or more packed beds, or some combination of trays and packing. As is often the case, the fractionation tower may consist of two sections, an upper rectifying section **16a** and a lower stripping section **16b**. The upper rectifying section **16a** contains trays and/or packing and provides the necessary contact between the vapor rising from the lower distillation or stripping section **16b** and a liquid stream (reflux) to remove the heavier hydrocarbon components from the vapor. The lower, stripping section **16b** also contains trays and/or packing and provides the necessary contact between the liquids falling downward and the vapors rising upward. The stripping section **16b** also includes at least one reboiler (such as the reboiler **17**) which heats and vaporizes a portion of the liquids flowing down the column to provide the stripping vapors which flow up the column to strip the liquid product, stream **39**, of lighter hydrocarbon components so that it contains only the heavier hydrocarbon components that were in the natural gas feed stream (stream **31**), whereupon it exits the bottom of the tower at 358°F [181°C].

[0018] The column overhead vapor (stream **36**) is withdrawn from the top of tower **16** at -6°F [-21°C] and is cooled to -18°F [-28°C] and partially condensed (stream **36a**) in heat exchanger **18** using a refrigerant. The operating pressure in reflux separator **19** is maintained

slightly below the operating pressure of tower **16**. This provides the driving force which causes overhead vapor stream **36** to flow through reflux condenser **18** and thence into the reflux separator **19** wherein the condensed liquid (stream **38**) is separated from the uncondensed vapor (stream **37**). The liquid stream **38** from reflux separator **19** is pumped by reflux pump **20** to a pressure slightly above the operating pressure of tower **16**, and stream **38a** is then supplied as cold top column feed (reflux) to tower **16**. This cold liquid reflux absorbs and condenses the heavier hydrocarbon components in the vapors rising up in rectifying section **16a** of tower **16**. The residue gas (vapor stream **37**) passes countercurrently to the incoming feed gas in heat exchanger **10** where it is heated to 55°F [13°C] as it provides cooling as previously described. The residue gas is then re-compressed in two stages, compressor **14** driven by expansion machine **13** and compressor **21** driven by a supplemental power source. (In the FIG. 1 process, compressor **21** consists of two compression stages with intercooling between the stages.) After stream **37c** is cooled in discharge cooler **22**, the residue gas product (stream **37d**) flows to the sales gas pipeline or to the liquefaction plant at 1603 psia [11,050 kPa(a)].

[0019] A summary of stream flow rates and energy consumption for the process illustrated in FIG. 1 is set forth in the following table:

Table I

(FIG. 1)

Stream Flow Summary - Lb. Moles/Hr [kg moles/Hr]

<u>Stream</u>	<u>Methane</u>	<u>Ethane</u>	<u>Propane</u>	<u>Butanes</u>	<u>Pentanes+</u>	<u>Total</u>
31	29,885	1,626	869	574	189	33,501
34	29,570	1,555	769	428	77	32,756
35	315	71	100	146	112	745
36	29,987	1,666	959	586	7	33,564
38	102	40	91	164	4	402
37	29,885	1,626	868	422	3	33,162
39	0	0	1	152	186	339

Recoveries*

Butanes 26.52%

Pentanes+ 98.42%

Power

Residue Gas Compression 15,290 HP [25,137 kW]

Refrigerant Compression 861 HP [1,415 kW]

Total Compression 16,151 HP [26,552 kW]

* (Based on un-rounded flow rates)

[0020] FIG. 2 is a process flow diagram showing the design of a processing plant to remove heavier hydrocarbon components from a natural gas stream using another prior art process. The process of FIG. 2 has been applied to the same feed gas composition and conditions as described previously for FIG. 1.

[0021] In this simulation of the process, inlet gas enters the plant at 60°F [15°C] and 995 psia [6,858 kPa(a)] as stream **31** and flows directly to work expansion machine **13** in which mechanical energy is extracted from the high pressure feed. The machine **13** expands the vapor substantially isentropically to the operating pressure (approximately 355 psia [2,446 kPa(a)]) of fractionation tower **16**, with the work expansion cooling the expanded stream **31a** to a temperature of approximately -34°F [-37°C] before it is supplied as feed to fractionation tower **16** at a mid-column feed point.

[0022] Liquid product stream **39** is stripped of the lighter hydrocarbon components and exits the bottom of tower **16** at 320°F [160°C]. The column overhead vapor (stream **36**) is withdrawn from the top of tower **16** at -8°F [-22°C] and is cooled to -24°F [-31°C] and partially condensed (stream **36a**) in heat exchanger **18** using a refrigerant, and the condensed liquid (stream **38**) is separated from the uncondensed vapor (stream **37**) in reflux separator **19**. Liquid stream **38** is pumped by reflux pump **20** to a pressure slightly above the operating pressure of tower **16**, and stream **38a** is then supplied as cold top column feed (reflux) to tower **16**. The residue gas (vapor stream **37**) is re-compressed in two stages, compressor **14** driven by expansion machine **13** and compressor **21** driven by a supplemental power source. (In the FIG. 2 process, compressor **21** consists of two compression stages with intercooling between the stages.) After stream **37b** is cooled in discharge cooler **22**, the residue gas product (stream **37c**) flows to the sales gas pipeline or to the liquefaction plant at 1603 psia [11,050 kPa(a)].

[0023] A summary of stream flow rates and energy consumption for the process illustrated in FIG. 2 is set forth in the following table:

Table II

(FIG. 2)

Stream Flow Summary - Lb. Moles/Hr [kg moles/Hr]

<u>Stream</u>	<u>Methane</u>	<u>Ethane</u>	<u>Propane</u>	<u>Butanes</u>	<u>Pentanes+</u>	<u>Total</u>
31	29,885	1,626	869	574	189	33,501
36	29,987	1,673	986	664	9	33,677
38	102	47	118	239	6	512
37	29,885	1,626	868	425	3	33,165
39	0	0	1	149	186	336

Recoveries*

Butanes	25.92%
Pentanes+	98.42%

Power

Residue Gas Compression	13,805 HP	[22,695 kW]
Refrigerant Compression	1,261 HP	[2,073 kW]
Total Compression	15,066 HP	[24,768 kW]

* (Based on un-rounded flow rates)

DESCRIPTION OF THE INVENTION

Example 1

[0024] FIG. 3 illustrates a flow diagram of a process in accordance with the present invention. The feed gas composition and conditions considered in the process presented in FIG. 3 are the same as those in FIG. 1. Accordingly, the FIG. 3 process can be compared with that of the FIG. 1 process to illustrate the advantages of the present invention.

[0025] In the process illustrated in FIG. 3, inlet gas enters the plant at 60°F [15°C] and 995 psia [6,858 kPa(a)] as stream **31** and is directed to a heat exchange means in feed cooling section **116a** inside processing assembly **116**. This heat exchange means may be comprised of a fin and tube type heat exchanger, a plate type heat exchanger, a brazed aluminum type heat exchanger, or other type of heat transfer device, including multi-pass and/or multi-service heat exchangers. The heat exchange means is configured to provide heat exchange between stream **31** flowing through one pass of the heat exchange means and flash expanded separator liquids (stream **35a**) and a residue gas stream from condensing section **116b** inside processing assembly **116**. Stream **31** is cooled while heating the flash expanded separator liquids and the residue gas stream.

[0026] Separator section **116e** has an internal head or other means to divide it from stripping section **116d**, so that the two sections inside processing assembly **116** can operate at different pressures. The cooled stream **31a** enters separator section **116e** at 4°F [-16°C] and 980 psia [6,755 kPa(a)] where any condensed liquid (stream **35**) is separated from the vapor (stream **34**). Stream **35** exits separator section **116e** and is expanded by expansion valve **15** to slightly above the operating pressure (470 psia [3,238 kPa(a)]) of stripping section **116d** inside processing assembly **116**, cooling stream **35a** to -17°F [-27°C]. Stream **35a** enters the heat

exchange means in feed cooling section **116a** to supply cooling to the feed gas as described previously, heating stream **35b** to 54°F [12°C] before it enters below a mass transfer means inside stripping section **116d** of processing assembly **116**.

[0027] The vapor (stream **34**) from separator section **116e** enters a work expansion machine **13** in which mechanical energy is extracted from this portion of the high pressure feed. The machine **13** expands the vapor substantially isentropically to the operating pressure of rectifying section **116c** inside processing assembly **116**, with the work expansion cooling the expanded stream **34a** to -59°F [-51°C]. The partially condensed expanded stream **34a** is thereafter supplied as feed between an absorbing means inside rectifying section **116c** and the mass transfer means inside stripping section **116d** of processing assembly **116**.

[0028] A heat and mass transfer means is located below the mass transfer means inside stripping section **116d**. The heat and mass transfer means may be comprised of a fin and tube type heat exchanger, a plate type heat exchanger, a brazed aluminum type heat exchanger, or other type of heat transfer device, including multi-pass and/or multi-service heat exchangers. The heat and mass transfer means is configured to provide heat exchange between a heating medium flowing through one pass of the heat and mass transfer means and a distillation liquid stream flowing downward from the lower region of the mass transfer means, so that the distillation liquid stream is heated. As the distillation liquid stream is heated, a portion of it is vaporized to form stripping vapors that rise upward to the mass transfer means as the remaining liquid continues flowing downward through the heat and mass transfer means. The heat and mass transfer means provides continuous contact between the stripping vapors and the distillation liquid stream so that it also functions to provide mass transfer between the vapor and liquid phases, stripping the liquid product stream **39** of lighter hydrocarbon components. The

stripping vapors produced in the heat and mass transfer means continue upward to the mass transfer means in stripping section **116d** to provide partial stripping of the lighter hydrocarbon components in the liquids flowing downward from the upper part of processing assembly **116**.

[0029] Another heat and mass transfer means is located inside condensing section **116b**, above the absorbing means inside rectifying section **116c** of processing assembly **116**. This heat and mass transfer means may also be comprised of a fin and tube type heat exchanger, a plate type heat exchanger, a brazed aluminum type heat exchanger, or other type of heat transfer device, including multi-pass and/or multi-service heat exchangers. The heat and mass transfer means is configured to provide heat exchange between a refrigerant stream flowing through one pass of the heat and mass transfer means and a distillation vapor stream arising from the upper region of the absorbing means flowing upward through the other pass, so that the distillation vapor stream is cooled by the refrigerant. As the distillation vapor stream is cooled, a portion of it is condensed and falls downward while the remaining distillation vapor stream continues flowing upward through the heat and mass transfer means. The heat and mass transfer means provides continuous contact between the condensed liquid and the distillation vapor stream so that it also functions to provide mass transfer between the vapor and liquid phases, thereby absorbing heavier hydrocarbon components from the distillation vapor stream to rectify it. The condensed liquid is collected from the bottom of the heat and mass transfer means and directed to the upper region of the absorbing means inside rectifying section **116c** to provide partial rectification of the heavier hydrocarbon components in the vapors flowing upward from the lower part of processing assembly **116**.

[0030] The absorbing means inside rectifying section **116c** and the mass transfer means inside stripping section **116d** each consist of a plurality of vertically spaced trays, one or more

packed beds, or some combination of trays and packing. The trays and/or packing in rectifying section **116c** and stripping section **116d** provide the necessary contact between the vapors rising upward and liquid falling downward. The liquid portion of expanded stream **34a** commingles with liquids falling downward from rectifying section **116c** and the combined liquids continue downward into stripping section **116d**, which vaporizes and strips the lighter hydrocarbon components from these liquids. The vapors arising from stripping section **116d** combine with the vapor portion of expanded stream **34a** and rise upward through rectifying section **116c**, to be contacted with the cold liquid falling downward to condense and absorb the heavier hydrocarbon components from these vapors.

[0031] The distillation liquid flowing downward from the heat and mass transfer means in stripping section **116d** inside processing assembly **116** has been stripped of the lighter hydrocarbon components so that it contains only the heavier hydrocarbon components that were in the natural gas feed stream (stream **31**), whereupon it exits the lower region of stripping section **116d** as stream **39** and leaves processing assembly **116** at 356°F [180°C]. The distillation vapor stream arising from condensing section **116b** is heated in feed cooling section **116a** as it provides cooling to stream **31** as described previously, whereupon residue gas stream **37** leaves processing assembly **116** at 55°F [13°C]. The residue gas stream is then re-compressed in two stages, compressor **14** driven by expansion machine **13** and compressor **21** driven by a supplemental power source. (In this example, compressor **21** consists of two compression stages with intercooling between the stages.) After cooling in discharge cooler **22**, residue gas stream **37c** flows to the sales gas pipeline or to the liquefaction plant at 1603 psia [11,050 kPa(a)].

[0032] A summary of stream flow rates and energy consumption for the process illustrated in FIG. 3 is set forth in the following table:

Table III

(FIG. 3)

Stream Flow Summary - Lb. Moles/Hr [kg moles/Hr]

<u>Stream</u>	<u>Methane</u>	<u>Ethane</u>	<u>Propane</u>	<u>Butanes</u>	<u>Pentanes+</u>	<u>Total</u>
31	29,885	1,626	869	574	189	33,501
34	29,571	1,555	769	428	77	32,758
35	314	71	100	146	112	743
37	29,885	1,626	868	423	3	33,164
39	0	0	1	151	186	337

Recoveries*

Butanes	26.26%
Pentanes+	98.42%

Power

Residue Gas Compression	15,289 HP	[25,135 kW]
Refrigerant Compression	846 HP	[1,391 kW]
Total Compression	16,135 HP	[26,526 kW]

* (Based on un-rounded flow rates)

[0033] A comparison of Tables I and III shows that, compared to the prior art, the compact processing assembly of the present invention maintains essentially the same butanes recovery and pentane+ recovery using slightly less power. However, the present invention offers at least two advantages over the prior art of FIG. 1. First, the compact arrangement of processing assembly **116** of the present invention replaces eight separate equipment items in the FIG. 1 prior art (heat exchangers **10** and **11**, separator **12**, fractionation tower **16**, reboiler **17**, reflux condenser **18**, reflux separator **19**, and reflux pump **20**) with a single equipment item (processing assembly **116** in FIG. 3 of the present invention). This reduces the "footprint" of the processing plant and eliminates the interconnecting piping, reducing the capital cost of the processing plant itself and (more importantly) the capital cost of the platform or ship on which it is installed. Second, elimination of the interconnecting piping means that a processing plant using the present invention has far fewer flanged connections compared to the prior art, reducing the number of potential leak sources in the plant. Hydrocarbons are volatile organic compounds (VOCs), some of which are classified as greenhouse gases and some of which may be precursors to atmospheric ozone formation, which means the present invention reduces the potential for atmospheric releases that may damage the environment.

Example 2

[0034] The present invention also offers advantages when circumstances favor expansion of the feed gas without cooling it first, as illustrated in FIG. 4. The feed gas composition and conditions considered in the process presented in FIG. 4 are the same as those in FIG. 2. Accordingly, the FIG. 4 process can be compared with that of the FIG. 2 process to further illustrate the advantages of the present invention.

[0035] In the process illustrated in FIG. 4, inlet gas enters the plant at 60°F [15°C] and 995 psia [6,858 kPa(a)] as stream **31** and is directed to work expansion machine **13** as stream **34**. Mechanical energy is extracted from the high pressure feed as machine **13** expands the vapor substantially isentropically to the operating pressure (355 psia [2,446 kPa(a)]) of rectifying section **116c** inside processing assembly **116**, with the work expansion cooling the expanded stream **34a** to -34°F [-37°C]. The partially condensed expanded stream **34a** is thereafter supplied as feed between an absorbing means inside rectifying section **116c** and a mass transfer means inside stripping section **116d** of processing assembly **116**.

[0036] A heat and mass transfer means is located below the mass transfer means inside stripping section **116d**. The heat and mass transfer means is configured to provide heat exchange between a heating medium flowing through one pass of the heat and mass transfer means and a distillation liquid stream flowing downward from the lower region of the mass transfer means, so that the distillation liquid stream is heated. As the distillation liquid stream is heated, a portion of it is vaporized to form stripping vapors that rise upward to the mass transfer means as the remaining liquid continues flowing downward through the heat and mass transfer means. The heat and mass transfer means provides continuous contact between the stripping vapors and the distillation liquid stream so that it also functions to provide mass transfer between the vapor and liquid phases, stripping the liquid product stream **39** of lighter hydrocarbon components. The stripping vapors produced in the heat and mass transfer means continue upward to the mass transfer means in stripping section **116d** to provide partial stripping of the lighter hydrocarbon components in the liquids flowing downward from the upper part of processing assembly **116**.

[0037] Another heat and mass transfer means is located inside condensing section **116b**, above the absorbing means inside rectifying section **116c** of processing assembly **116**. The heat

and mass transfer means is configured to provide heat exchange between a refrigerant stream flowing through one pass of the heat and mass transfer means and a distillation vapor stream arising from the upper region of the absorbing means flowing upward through the other pass, so that the distillation vapor stream is cooled by the refrigerant. As the distillation vapor stream is cooled, a portion of it is condensed and falls downward while the remaining distillation vapor stream continues flowing upward through the heat and mass transfer means. The heat and mass transfer means provides continuous contact between the condensed liquid and the distillation vapor stream so that it also functions to provide mass transfer between the vapor and liquid phases, thereby absorbing heavier hydrocarbon components from the distillation vapor stream to rectify it. The condensed liquid is collected from the bottom of the heat and mass transfer means and directed to the upper region of the absorbing means inside rectifying section **116c** to provide partial rectification of the heavier hydrocarbon components in the vapors flowing upward from the lower part of processing assembly **116**.

[0038] The distillation liquid flowing downward from the heat and mass transfer means in stripping section **116d** inside processing assembly **116** has been stripped of the lighter hydrocarbon components so that it contains only the heavier hydrocarbon components that were in the natural gas feed stream (stream **31**), whereupon it exits the lower region of stripping section **116d** as stream **39** and leaves processing assembly **116** at 318°F [159°C]. The distillation vapor stream arising from condensing section **116b** is residue gas stream **37**, which leaves processing assembly **116** at -25°F [-32°C]. The residue gas stream is re-compressed in two stages, compressor **14** driven by expansion machine **13** and compressor **21** driven by a supplemental power source. (In this example, compressor **21** consists of two compression stages

with intercooling between the stages.) After cooling in discharge cooler **22**, residue gas stream **37d** flows to the sales gas pipeline or to the liquefaction plant at 1603 psia [11,050 kPa(a)].

[0039] A summary of stream flow rates and energy consumption for the process illustrated in FIG. 4 is set forth in the following table:

Table IV

(FIG. 4)

Stream Flow Summary - Lb. Moles/Hr [kg moles/Hr]

<u>Stream</u>	<u>Methane</u>	<u>Ethane</u>	<u>Propane</u>	<u>Butanes</u>	<u>Pentanes+</u>	<u>Total</u>
31 / 34	29,885	1,626	869	574	189	33,501
37	29,885	1,626	868	421	3	33,162
39	0	0	1	153	186	339

Recoveries*

Butanes	26.70%
Pentanes+	98.42%

Power

Residue Gas Compression	13,788 HP	[22,667 kW]
Refrigerant Compression	1,269 HP	[2,086 kW]
Total Compression	15,057 HP	[24,753 kW]

* (Based on un-rounded flow rates)

[0040] A comparison of Tables II and IV shows that, compared to the prior art, the compact processing assembly of the present invention maintains essentially the same butanes recovery and pentane+ recovery using slightly less power. However, the present invention offers at least two advantages over the prior art of FIG. 2. First, the compact arrangement of processing assembly **116** of the present invention replaces five separate equipment items in the FIG. 2 prior art (fractionation tower **16**, reboiler **17**, reflux condenser **18**, reflux separator **19**, and reflux pump **20**) with a single equipment item (processing assembly **116** in FIG. 4 of the present invention). This reduces the "footprint" of the processing plant and eliminates the interconnecting piping, reducing the capital cost of the processing plant itself and (more importantly) the capital cost of the platform or ship on which it is installed. Second, elimination of the interconnecting piping means that a processing plant using the present invention has far fewer flanged connections compared to the prior art, reducing the number of potential leak sources in the plant. Hydrocarbons are volatile organic compounds (VOCs), some of which are classified as greenhouse gases and some of which may be precursors to atmospheric ozone formation, which means the present invention reduces the potential for atmospheric releases that may damage the environment.

Other Embodiments

[0041] Some circumstances may favor eliminating feed cooling section **116a** from processing assembly **116** in order to reduce the height of processing assembly **116**. As shown in FIGS. 4 and 6, in such cases heat exchanger **10** can be used to provide the cooling of the feed gas (stream **31**). In other circumstances, it may be advantageous not to cool the feed gas at all, so that stream **34** is warmer and its work expansion in expansion machine **13** generates more power

for compressor **14**. In such circumstances, heat exchanger **10** in FIGS. 4 and 6 may not be required.

[0042] In some circumstances, it may be advantageous to use an external separator vessel to separate cooled feed stream **31a**, rather than including separator section **116e** in processing assembly **116**. As shown in FIGS. 4 and 5, separator **12** can be used to separate cooled feed stream **31a** into vapor stream **34** and liquid stream **35**.

[0043] Depending on the quantity of heavier hydrocarbons in the feed gas and the feed gas pressure, the cooled feed stream **31a** entering separator section **116e** in FIGS. 3 and 6 or separator **12** in FIGS. 4 and 5 may not contain any liquid (because it is above its dewpoint, or because it is above its cricondenbar). In such cases, there is no liquid in stream **35** (as shown by the dashed lines). In such circumstances, separator section **116e** in processing assembly **116** (FIGS. 3 and 6) or separator **12** (FIGS. 4 and 5) may not be required.

[0044] Feed gas conditions, plant size, available equipment, or other factors may indicate that elimination of work expansion machine **13**, or replacement with an alternate expansion device (such as an expansion valve), is feasible. Although individual stream expansion is depicted in particular expansion devices, alternative expansion means may be employed where appropriate. For example, conditions may warrant work expansion of the separator liquid (stream **35**).

[0045] In accordance with the present invention, the use of external refrigeration to supplement the cooling available to the inlet gas from the distillation vapor and separator liquid streams may be employed, particularly in the case of a rich inlet gas. In such cases, a heat and mass transfer means may be included in separator section **116e** (or a collecting means in such cases when the cooled feed stream **31a** contains no liquid) as shown by the dashed lines in

FIGS. 3 and 6, or a heat and mass transfer means may be included in separator **12** as shown by the dashed lines in FIGS. 4 and 5. This heat and mass transfer means may be comprised of a fin and tube type heat exchanger, a plate type heat exchanger, a brazed aluminum type heat exchanger, or other type of heat transfer device, including multi-pass and/or multi-service heat exchangers. The heat and mass transfer means is configured to provide heat exchange between a refrigerant stream (e.g., propane) flowing through one pass of the heat and mass transfer means and the vapor portion of stream **31a** flowing upward, so that the refrigerant further cools the vapor and condenses additional liquid, which falls downward to become part of the liquid removed in stream **35**. Alternatively, conventional gas chiller(s) could be used to cool stream **31a** with refrigerant before stream **31a** enters separator section **116e** (FIGS. 3 and 6) or separator **12** (FIGS. 4 and 5).

[0046] Depending on the type of heat transfer device selected for the heat exchange means in feed cooling section **116a** and the type of heat and mass transfer device selected for the heat and mass transfer means in condensing section **116b**, it may be possible to combine these in a single multi-pass and/or multi-service heat and mass transfer device. In such cases, the multi-pass and/or multi-service heat and mass transfer device will include appropriate means for distributing, segregating, and collecting streams **31/31a**, streams **35a/35b**, and the distillation vapor stream in order to accomplish the desired cooling and heating.

[0047] While there have been described what are believed to be preferred embodiments of the invention, those skilled in the art will recognize that other and further modifications may be made thereto, e.g. to adapt the invention to various conditions, types of feed, or other

requirements without departing from the spirit of the present invention as defined by the following claims.

WE CLAIM:

1. A process for the separation of a gas stream containing methane, C₂ components, C₃ components, C₄ components, C₅ components, and heavier hydrocarbon components into a volatile residue gas fraction and a relatively less volatile fraction containing a major portion of said C₅ components and heavier hydrocarbon components wherein

(1) said gas stream is expanded to lower pressure;

(2) said expanded gas stream is supplied as a feed between an absorbing means and a mass transfer means housed in a processing assembly, said absorbing means being located above said mass transfer means;

(3) a first distillation vapor stream is collected from an upper region of said absorbing means and cooled in a first heat and mass transfer means housed in said processing assembly to simultaneously condense the less volatile components from said first distillation vapor stream, thereby forming a condensed stream and a second distillation vapor stream, whereupon said second distillation vapor stream is discharged from said processing assembly as said volatile residue gas fraction;

(4) said condensed stream is supplied as a top feed to said absorbing means;

(5) a distillation liquid stream is collected from a lower region of said mass transfer means and heated in a second heat and mass transfer means housed in said processing assembly to simultaneously strip the more volatile components from said distillation liquid stream, whereupon said heated and stripped distillation liquid stream is discharged from said processing assembly as said relatively less volatile fraction; and

(6) a control means is adapted to maintain the temperature of said second distillation vapor stream at a temperature whereby the major portion of said C₅ components and heavier hydrocarbon components are recovered in said relatively less volatile fraction.

2. The process according to claim 1 wherein

(a) said gas stream is cooled; and

(b) said cooled gas stream is expanded to said lower pressure and supplied as said feed between said absorbing means and said mass transfer means.

3. The process according to claim 1 wherein

(a) said gas stream is cooled sufficiently to partially condense it;

(b) said partially condensed gas stream is supplied to a separating means and is separated therein to provide a vapor stream and at least one liquid stream;

(c) said vapor stream is expanded to said lower pressure and supplied as said feed between said absorbing means and said mass transfer means; and

(d) at least a portion of said at least one liquid stream is expanded to said lower pressure and heated, and thereafter is supplied as an additional feed to said processing assembly below said mass transfer means.

4. The process according to claim 2 wherein said second distillation vapor stream is heated in one or more heat exchange means housed in said processing assembly, thereby to supply at least a portion of the cooling of step (a), and thereafter discharging said heated second distillation vapor stream from said processing assembly as said volatile residue gas fraction.

5. The process according to claim 3 wherein said second distillation vapor stream is heated in one or more heat exchange means housed in said processing assembly, thereby to supply at least a portion of the cooling of step (a), and thereafter discharging said heated second distillation vapor stream from said processing assembly as said volatile residue gas fraction.

6. The process according to claim 3 or 5 wherein said separating means is housed in said processing assembly.

7. The process according to claim 2 or 4 wherein

- (a) a collecting means is housed in said processing assembly;
- (b) an additional heat and mass transfer means is included inside said collecting means, said additional heat and mass transfer means including one or more passes for an external refrigeration medium;
- (c) said cooled gas stream is supplied to said collecting means and directed to said additional heat and mass transfer means to be further cooled by said external refrigeration medium; and
- (d) said further cooled gas stream is expanded to said lower pressure and supplied as said feed between said absorbing means and said mass transfer means.

8. The process according to claim 3 or 5 wherein

- (a) an additional heat and mass transfer means is included inside said separating means, said additional heat and mass transfer means including one or more passes for an external refrigeration medium;

(b) said vapor stream is directed to said additional heat and mass transfer means to be cooled by said external refrigeration medium to form additional condensate; and

(c) said additional condensate becomes a part of said at least one liquid stream separated therein.

9. The process according to claim 6 wherein

(a) an additional heat and mass transfer means is included inside said separating means, said additional heat and mass transfer means including one or more passes for an external refrigeration medium;

(b) said vapor stream is directed to said additional heat and mass transfer means to be cooled by said external refrigeration medium to form additional condensate; and

(c) said additional condensate becomes a part of said at least one liquid stream separated therein.

10. An apparatus for the separation of a gas stream containing methane, C₂ components, C₃ components, C₄ components, C₅ components, and heavier hydrocarbon components into a volatile residue gas fraction and a relatively less volatile fraction containing a major portion of said C₅ components and heavier hydrocarbon components comprising

(1) expansion means connected to receive said gas stream under pressure and expand it to a lower pressure;

(2) a processing assembly connected to said expansion means to receive said expanded gas stream as a feed between an absorbing means and a mass transfer

means housed in said processing assembly, said absorbing means being located above said mass transfer means;

(3) vapor collecting means housed in said processing assembly and connected to said absorbing means to receive a first distillation vapor stream from an upper region of said absorbing means;

(4) first heat and mass transfer means housed in said processing assembly and connected to said vapor collecting means to receive said first distillation vapor stream and cool it while simultaneously condensing the less volatile components from said first distillation vapor stream, thereby forming a condensed stream and a second distillation vapor stream, whereupon said second distillation vapor stream is discharged from said processing assembly as said volatile residue gas fraction;

(5) said absorbing means being further connected to said first heat and mass transfer means to receive said condensed stream as a top feed thereto;

(6) liquid collecting means housed in said processing assembly and connected to said mass transfer means to receive a distillation liquid stream from a lower region of said mass transfer means;

(7) second heat and mass transfer means housed in said processing assembly and connected to said liquid collecting means to receive said distillation liquid stream and heat it, thereby simultaneously stripping the more volatile components from said distillation liquid stream, whereupon said heated and stripped distillation liquid stream is discharged from said processing assembly as said relatively less volatile fraction; and

(8) control means adapted to maintain the temperature of said second distillation vapor stream at a temperature whereby the major portion of said C₅ components and heavier hydrocarbon components are recovered in said relatively less volatile fraction.

11. The apparatus according to claim 10 wherein

(a) one or more heat exchange means is connected to receive said gas stream under pressure and cool it; and

(b) said expansion means is adapted to be connected to said one or more heat exchange means to receive said cooled gas stream and expand it to said lower pressure, whereupon said expanded cooled gas stream is supplied to said processing assembly as said feed between said absorbing means and said mass transfer means.

12. The apparatus according to claim 10 wherein

(a) one or more heat exchange means is connected to receive said gas stream under pressure and cool it sufficiently to partially condense it;

(b) a separating means is connected to said one or more heat exchange means to receive said partially condensed gas stream and separate it into a vapor stream and at least one liquid stream;

(c) said expansion means is adapted to be connected to said separating means to receive said vapor stream and expand it to said lower pressure, whereupon said expanded vapor stream is supplied to said processing assembly as said feed between said absorbing means and said mass transfer means;

(d) an additional expansion means is connected to said separating means to receive at least a portion of said at least one liquid stream and expand it to said lower pressure, thereby forming an expanded liquid stream; and

(e) a heating means is connected to said additional expansion means to receive said expanded liquid stream and heat it, said heating means being further connected to said processing assembly to supply said heated expanded liquid stream as an additional feed to said processing assembly below said mass transfer means.

13. The apparatus according to claim 11 wherein

(i) said one or more heat exchange means is housed in said processing assembly; and

(ii) said one or more heat exchange means is further connected to said first heat and mass transfer means to receive said second distillation vapor stream and heat it, thereby to supply at least a portion of the cooling of element (a), and thereafter discharging said heated second distillation vapor stream from said processing assembly as said volatile residue gas fraction.

14. The apparatus according to claim 12 wherein

(i) said one or more heat exchange means is housed in said processing assembly; and

(ii) said one or more heat exchange means is further connected to said first heat and mass transfer means to receive said second distillation vapor stream and heat it, thereby to supply at least a portion of the cooling of element (a), and thereafter discharging said heated second distillation vapor stream from said processing assembly as said volatile residue gas fraction.

15. The apparatus according to claim 12 or 14 wherein said separating means is housed in said processing assembly.

16. The apparatus according to claim 11 or 13 wherein

(a) a collecting means is housed in said processing assembly;

(b) an additional heat and mass transfer means is included inside said collecting means, said additional heat and mass transfer means including one or more passes for an external refrigeration medium;

(c) said collecting means is connected to said one or more heat exchange means to receive said cooled gas stream and direct it to said additional heat and mass transfer means to be further cooled by said external refrigeration medium; and

(d) said expansion means is adapted to be connected to said collecting means to receive said further cooled gas stream and expand it to said lower pressure, whereupon said expanded further cooled gas stream is supplied to said processing assembly as said feed between said absorbing means and said mass transfer means.

17. The apparatus according to claim 12 or 14 wherein

(a) an additional heat and mass transfer means is included inside said separating means, said additional heat and mass transfer means including one or more passes for an external refrigeration medium;

(b) said vapor stream is directed to said additional heat and mass transfer means to be cooled by said external refrigeration medium to form additional condensate; and

(c) said additional condensate becomes a part of said at least one liquid stream separated therein.

18. The apparatus according to claim 15 wherein

(a) an additional heat and mass transfer means is included inside said separating means, said additional heat and mass transfer means including one or more passes for an external refrigeration medium;

(b) said vapor stream is directed to said additional heat and mass transfer means to be cooled by said external refrigeration medium to form additional condensate;
and

(c) said additional condensate becomes a part of said at least one liquid stream separated therein.

+

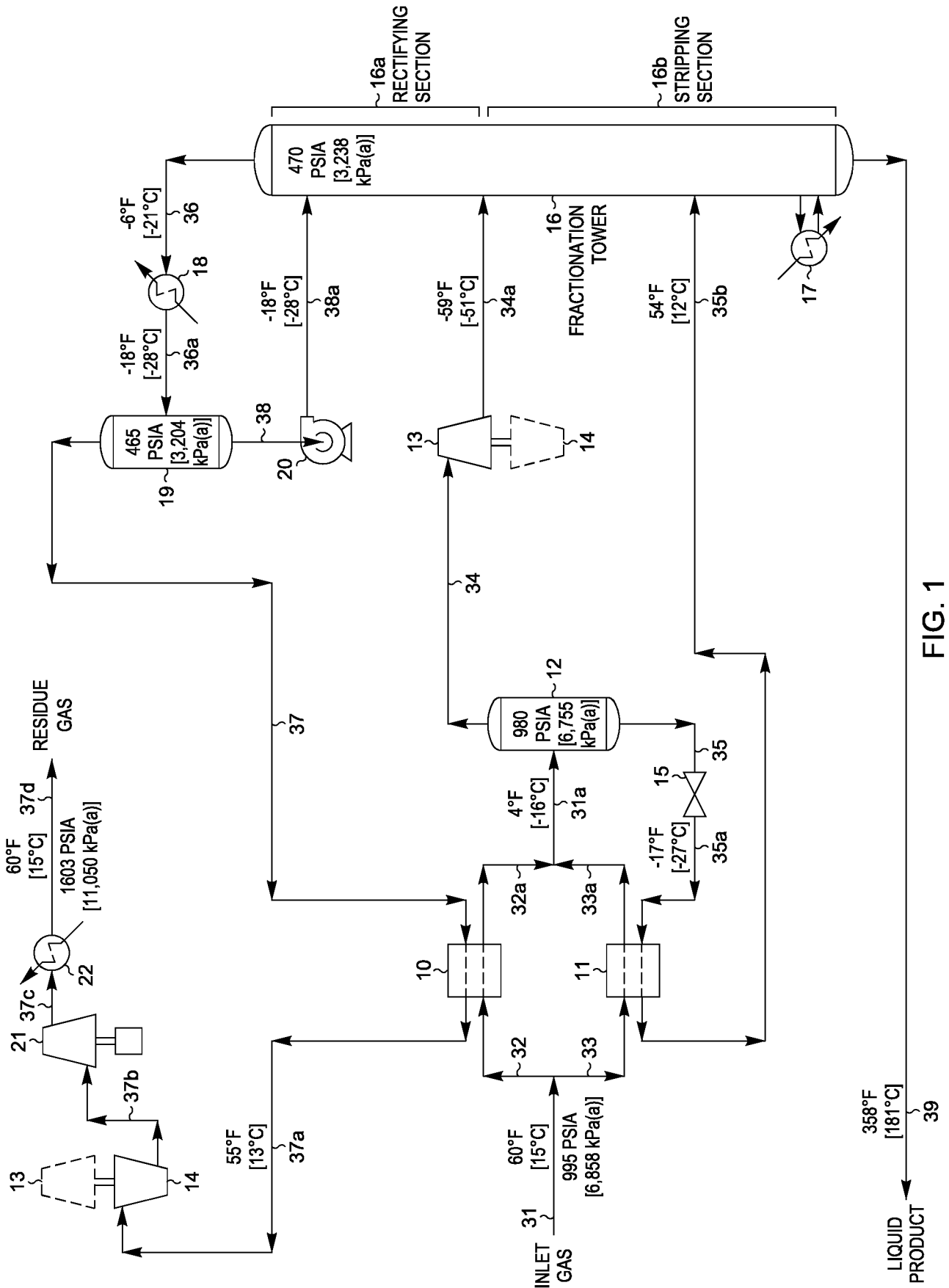

FIG. 1
(PRIOR ART)

+

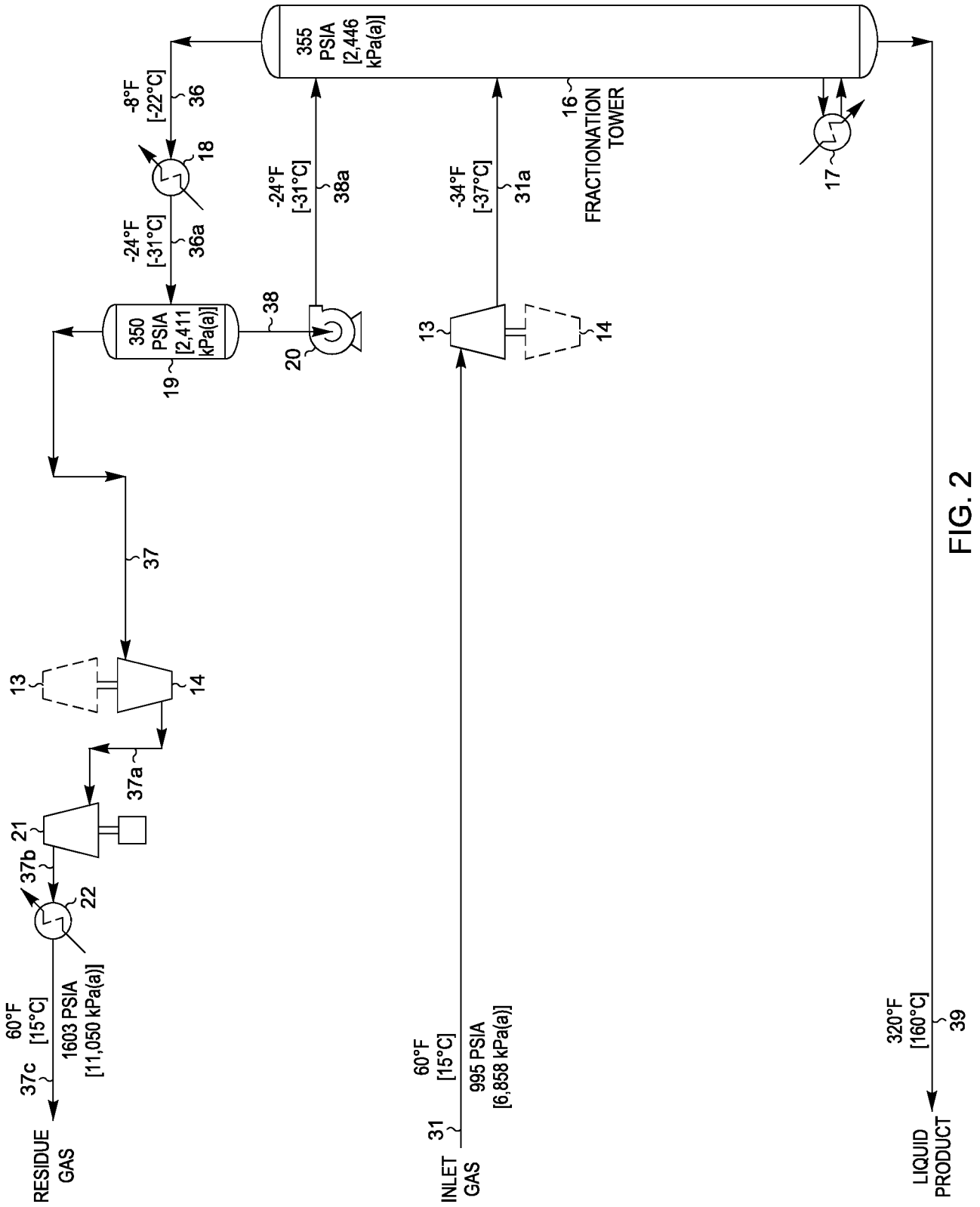

FIG. 2
(PRIOR ART)

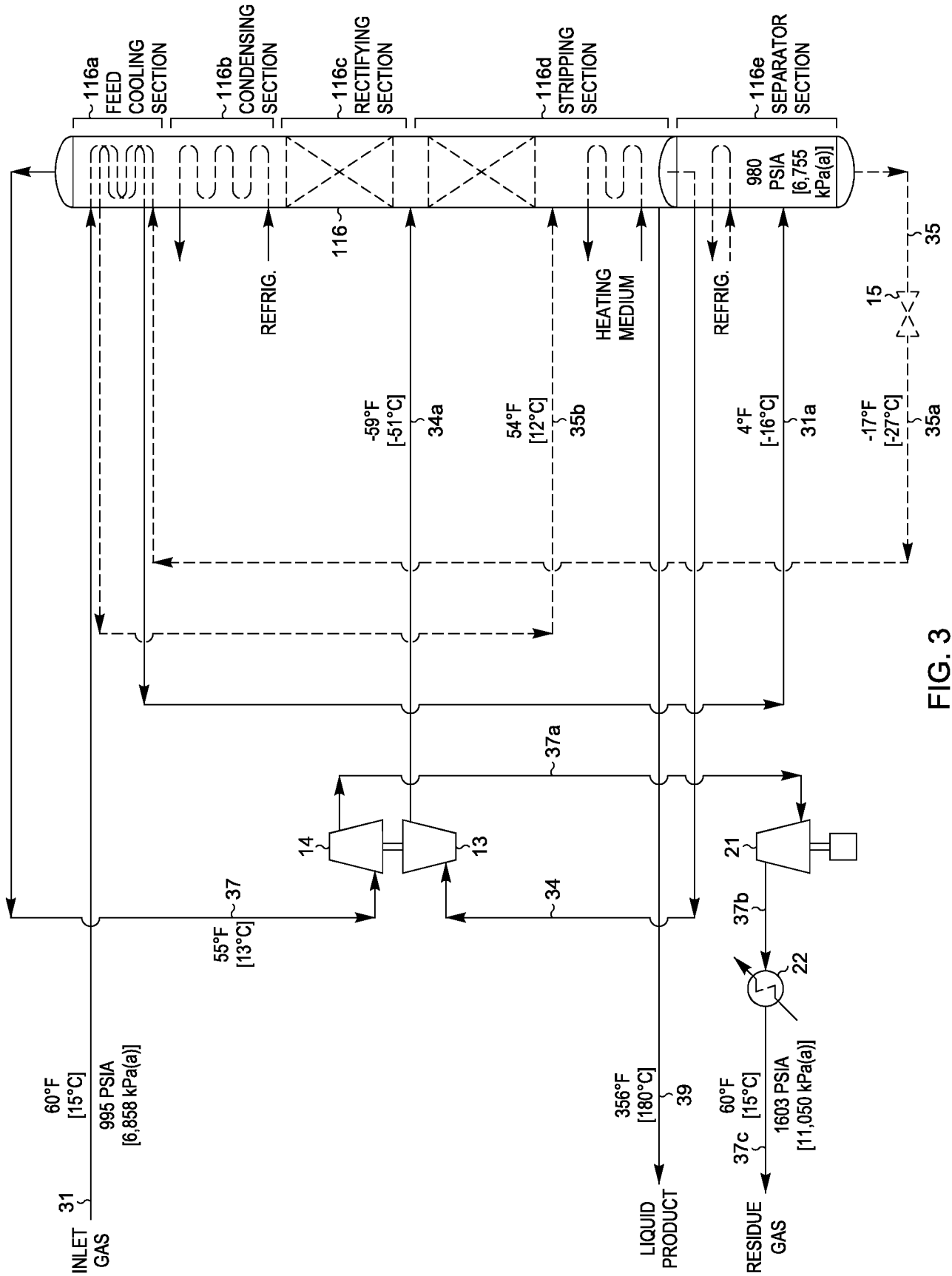

FIG. 3

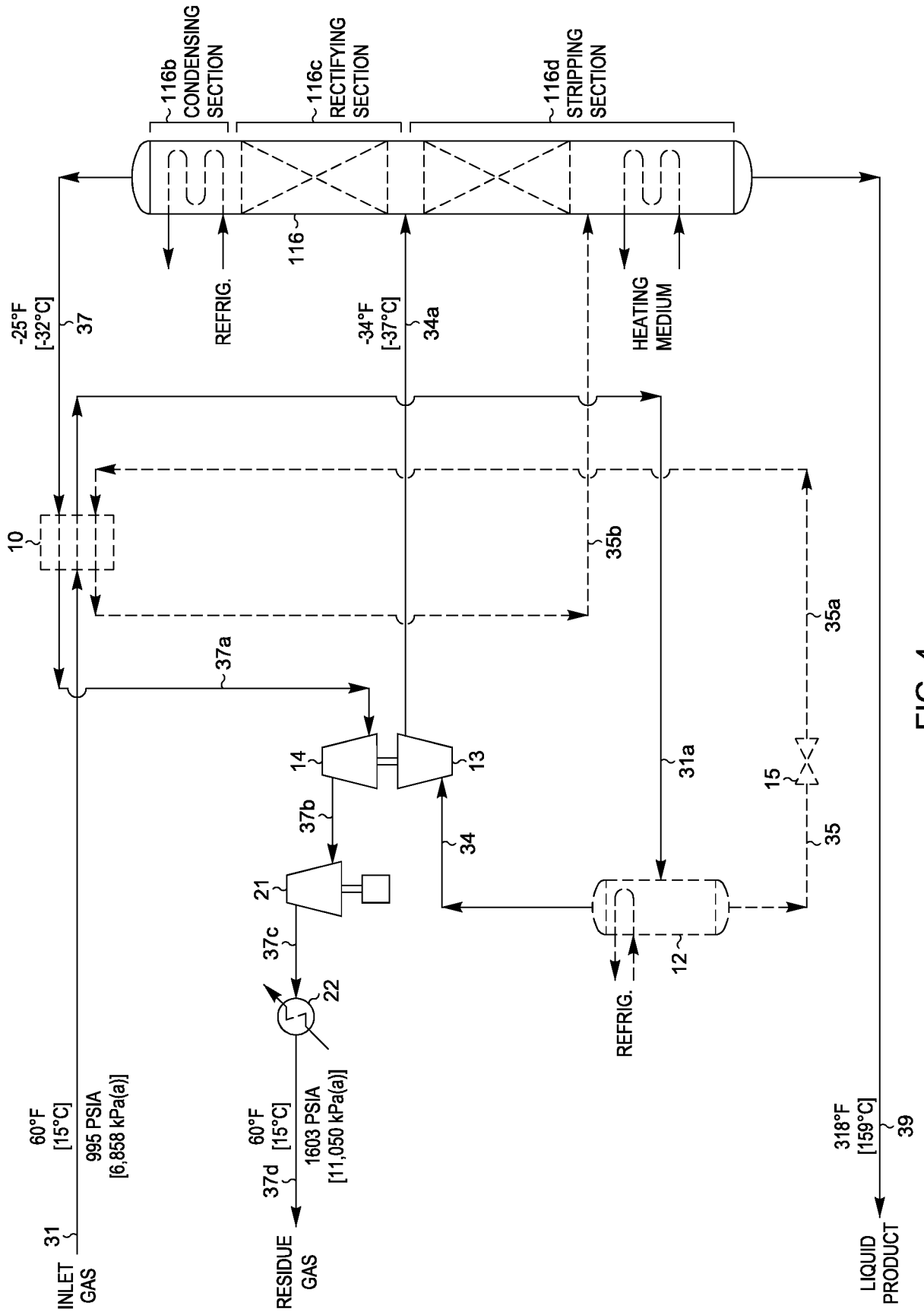

FIG. 4

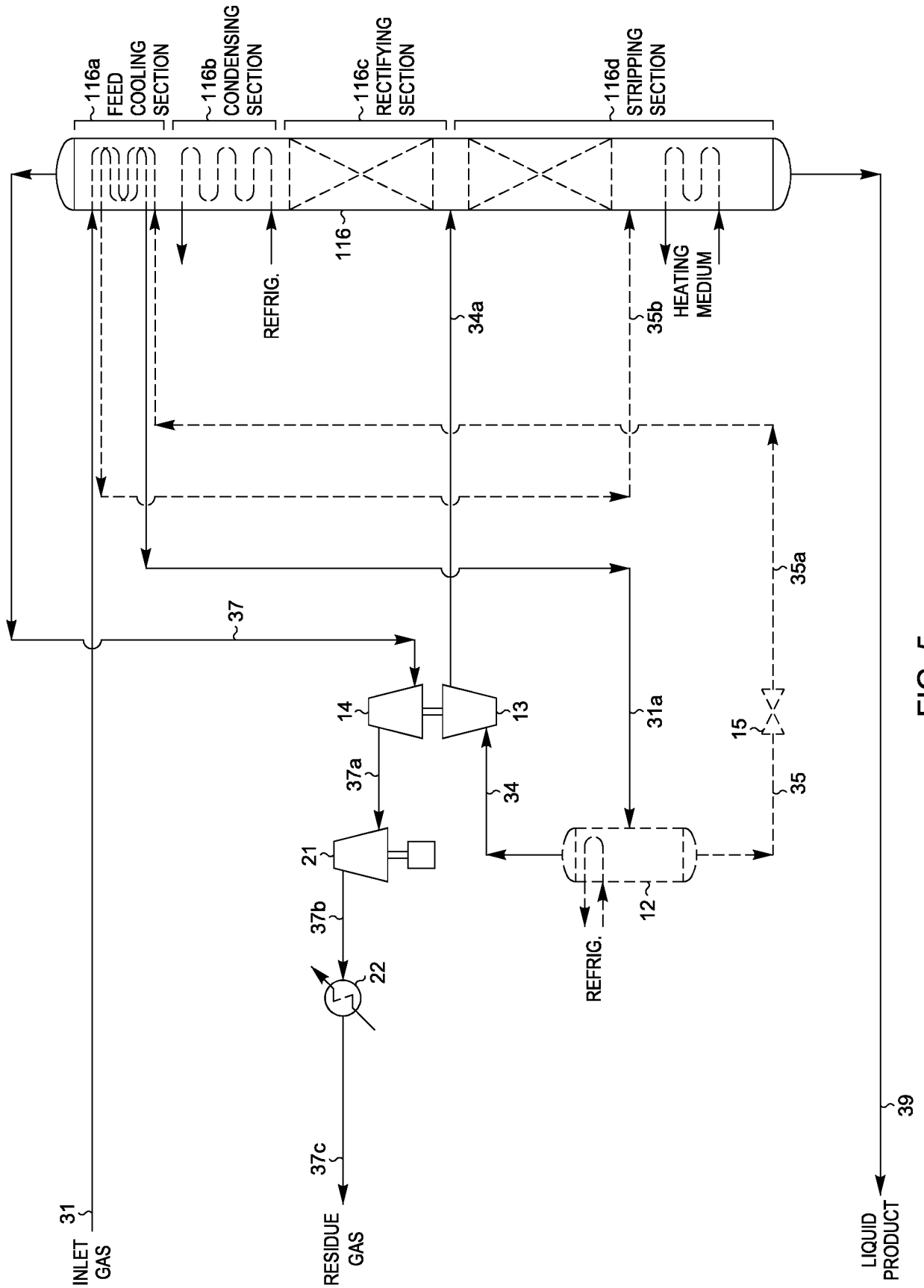

FIG. 5

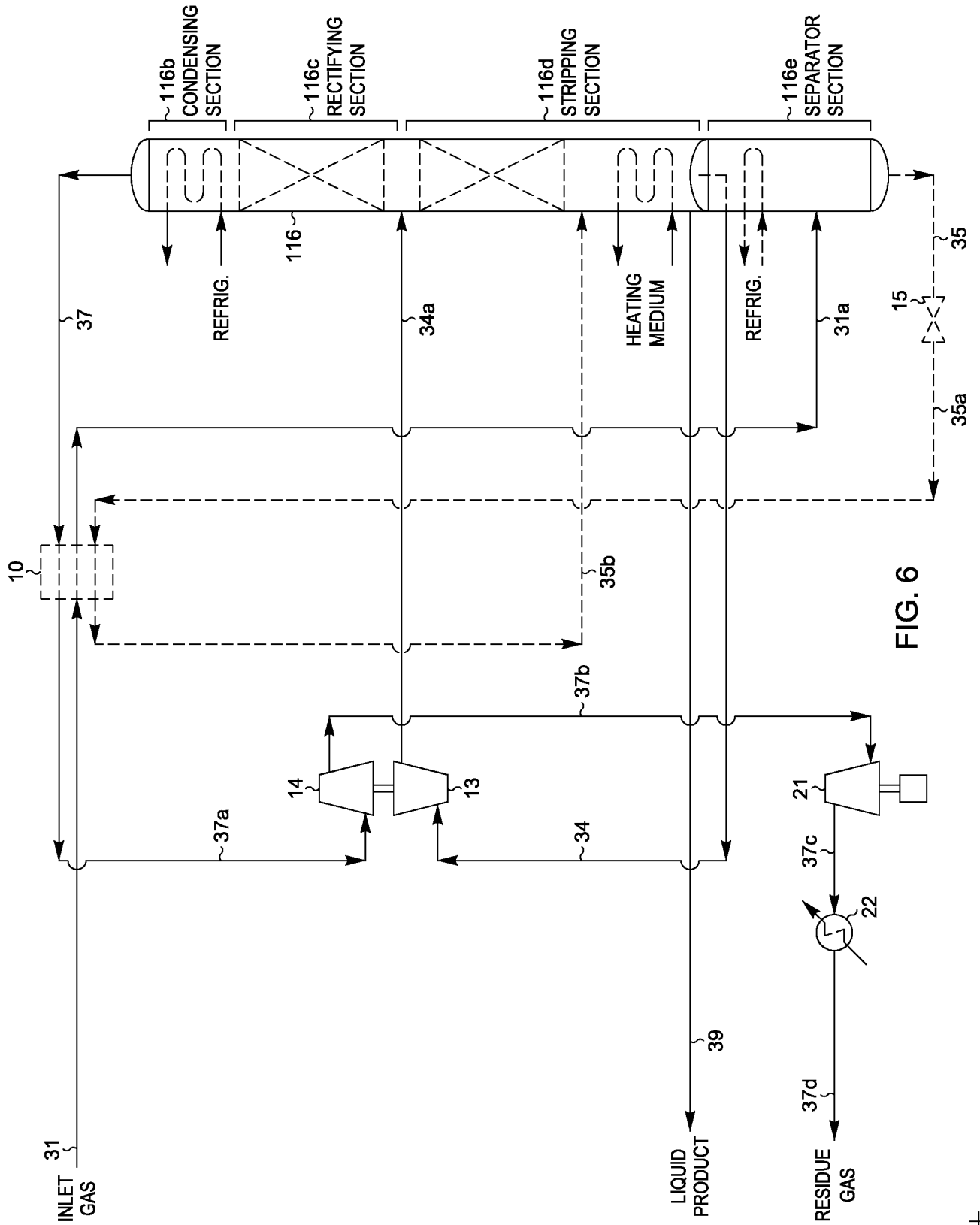

FIG. 6

INTERNATIONAL SEARCH REPORT

014/051548-23-11-2014
International application No.

PCT/US14/51548

A. CLASSIFICATION OF SUBJECT MATTER

IPC(8) - F25J 3/02, 3/06, 3/08 (2014.01)

CPC - B01D 3/14, 3/141; F25J 3/0209

According to International Patent Classification (IPC) or to both national classification and IPC

B. FIELDS SEARCHED

Minimum documentation searched (classification system followed by classification symbols)

IPC(8): B01D 3/14, 3/26, 3/42; C07C 7/04, 7/09, 7/11; C10G 31/08; F25J 1/00, 3/00, 3/02, 3/08 (2014.01)

CPC: B01D 3/14, 3/141, 3/26, 3/42, 5/0036; C07C 7/04, 7/09, 7/11; F25J 1/00, 3/00, 3/02, 3/0209, 3/061, 3/065, 3/08

Documentation searched other than minimum documentation to the extent that such documents are included in the fields searched

USPC: 62/613, 617, 619, 620, 621, 623, 625, 628, 632, 636; 203/42, 88; 585/800, 802

Electronic data base consulted during the international search (name of data base and, where practicable, search terms used)

MicroPatent (US-G, US-A, EP-A, EP-B, WO, JP-bib, DE-C,B, DE-A, DE-T, DE-U, GB-A, FR-A); Google; Google Scholar; ProQuest; IP.com; absorbing, bottom, column, condensate, cooling, expand, heat transfer, liquid, mass transfer, methane, heavy, recover, refrigerant, separate, separator, stripping, vapor

C. DOCUMENTS CONSIDERED TO BE RELEVANT

Category*	Citation of document, with indication, where appropriate, of the relevant passages	Relevant to claim No.
X — Y	US 2011/0226014 A1 (JOHNKE, AF et al.) 22 September 2011; figures 3, 4; paragraphs [0003], [0037], [0051]-[0057], [0062], [0067]]; claims 1, 23	1-2, 4-5, 6/5, 7/2, 7/4, 8/5, 9/6/5, 10-11, 13, 16/11, 16/13 3, 6/3, 8/3, 9/6/3, 12, 14, 15/12, 15/14, 17/12, 17/14, 18/15/12, 18/15/14
Y	US 2010/0275647 A1 (JOHNKE, AF et al.) 04 November 2010; figure 2; paragraphs [0009], [0031], [0036]-[0037]	3, 6/3, 8/3, 9/6/3, 12, 14, 15/12, 15/14, 17/12, 17/14, 18/15/12, 18/15/14
A	US 2001/0008073 A1 (FINN, AJ et al.) 19 July 2001; entire document, especially figure 2	1-18
A	US 3,111,402 A (CUNNINGHAM, FC) 19 November 1963; entire document, especially figure 2	1-18
A	US 5,890,378 A (RAMBO, CL et al.) 06 April 1999; entire document, especially figure 6	1-18
A	US 2011/0226012 A1 (JOHNKE, AF et al.) 22 September 2011; entire document, especially figure 5	1-18
A	US 2010/0251764 A1 (JOHNKE, AF et al.) 07 October 2010; entire document, especially figure 5	1-18

 Further documents are listed in the continuation of Box C.

* Special categories of cited documents:

"A" document defining the general state of the art which is not considered to be of particular relevance

"E" earlier application or patent but published on or after the international filing date

"L" document which may throw doubts on priority claim(s) or which is cited to establish the publication date of another citation or other special reason (as specified)

"O" document referring to an oral disclosure, use, exhibition or other means

"P" document published prior to the international filing date but later than the priority date claimed

"T" later document published after the international filing date or priority date and not in conflict with the application but cited to understand the principle or theory underlying the invention

"X" document of particular relevance; the claimed invention cannot be considered novel or cannot be considered to involve an inventive step when the document is taken alone

"Y" document of particular relevance; the claimed invention cannot be considered to involve an inventive step when the document is combined with one or more other such documents, such combination being obvious to a person skilled in the art

"&" document member of the same patent family

Date of the actual completion of the international search

23 October 2014 (23.10.2014)

Date of mailing of the international search report

25 NOV 2014

Name and mailing address of the ISA/US

Mail Stop PCT, Attn: ISA/US, Commissioner for Patents
P.O. Box 1450, Alexandria, Virginia 22313-1450
Facsimile No. 571-273-3201

Authorized officer:

Shane Thomas

PCT Helpdesk: 571-272-4300
PCT OSP: 571-272-7774