

[72] Inventor **William D. Coski**  
 Mercer Island, Wash.  
 [21] Appl. No. **834,745**  
 [22] Filed **June 19, 1969**  
 [45] Patented **Aug. 24, 1971**  
 [73] Assignee **Lawrence Manufacturing Company**  
 Seattle, Wash.

2,899,222	8/1959	Ross .....	287/53
3,112,941	12/1963	Dutton .....	287/53
3,326,580	6/1967	Munier et al. ....	287/53 X
3,338,228	8/1967	Giles .....	287/53 X
3,434,366	3/1969	Raso et al. ....	287/53 X
3,454,305	7/1969	Gilmour, Jr. ....	287/53 X

*Primary Examiner*—David J. Williamowski  
*Assistant Examiner*—Wayne L. Shedd  
*Attorneys*—Carl R. Horten, David W. Tibbott and Bernard J. Murphy

[54] **PILOT CUTTER MOUNTING ASSEMBLY**  
 13 Claims, 3 Drawing Figs.

[52] U.S. Cl. .... 287/53  
 [51] Int. Cl. .... F16d 1/06  
 [50] Field of Search ..... 287/53, 53  
 S, 53 H, 53 LK, 111, 52.09, 52.06, 52.04, 53 TK,  
 52.01, 52.02, 113

[56] **References Cited**  
**UNITED STATES PATENTS**  
 1,175,100 3/1916 Werner ..... 287/53

**ABSTRACT:** A pilot cutter mounting assembly comprising a segmented collar having both a keyway and an annular groove for engaging the cutter shaft with both a key and an annular thrust ring. The collar has a radial rim which supports studs for mounting the cutter support, and receives jacking screws for removing the cutting support.

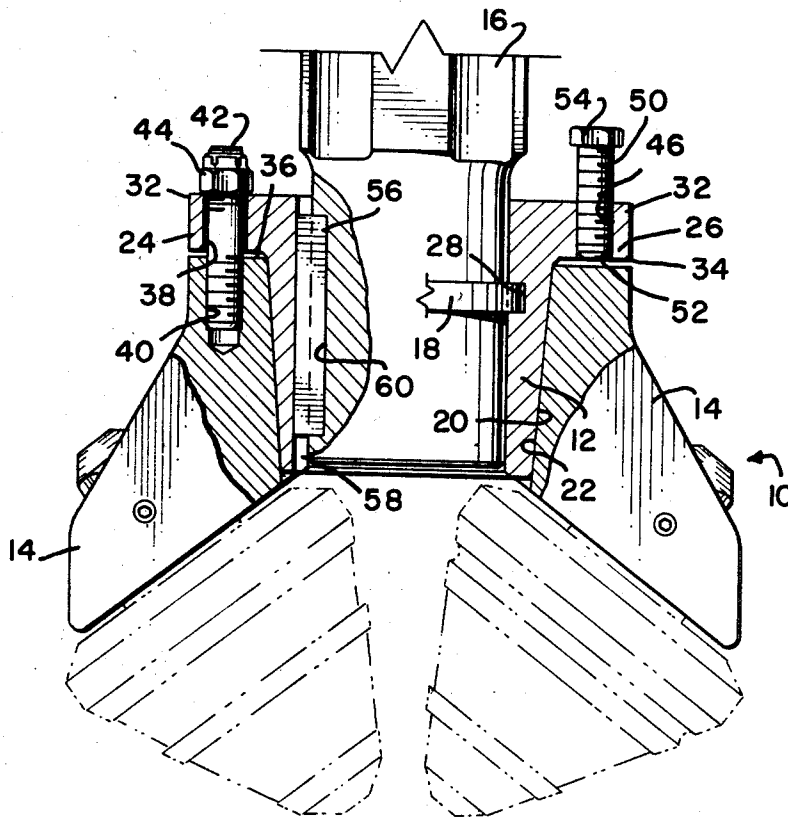

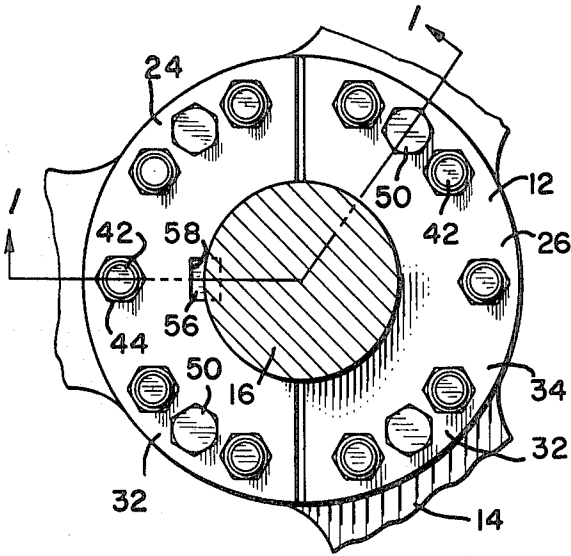

FIG. 2

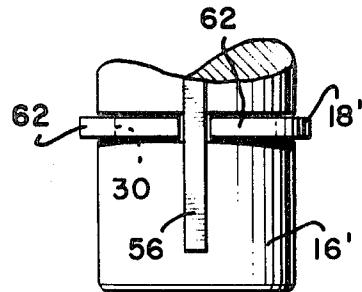

FIG. 3

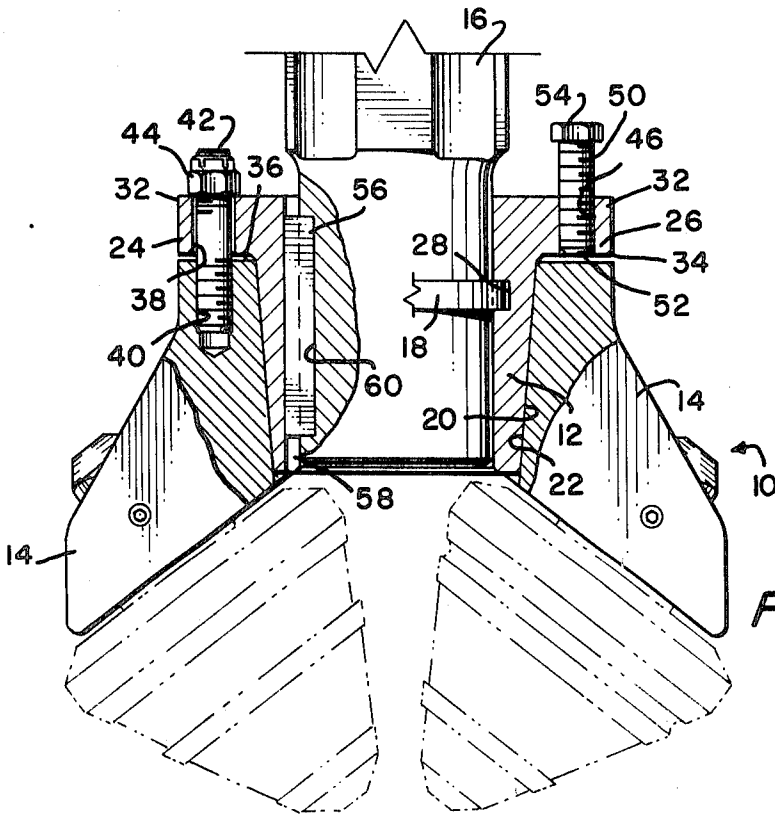

FIG. 1

INVENTOR

WILLIAM D. COSKI

BY

*Bernard J. Murphy*

AGENT

## PILOT CUTTER MOUNTING ASSEMBLY

This invention pertains to a pilot cutter mounting assembly and in particular to a pilot cutter mounting assembly which facilitates removal of the cutters with the support from the cutter shaft.

In the prior art it is commonly known to mount a cutter support to a cutter shaft by means comprising a collar or the like which is rigidly bolted to the cutter shaft or threaded thereto, and which is in turn bolted to the cutter support. Such mounting arrangements provide a rather rigid structure which is therefore not easily disassembled.

It is an object of this invention to provide a pilot cutter mounting assembly comprising means for surely and rigidly coupling a cutter support to a cutter shaft, the novel assembly nonetheless facilitating a quick disassembly and removal of the cutter support and the cutters. It is another object of this invention to provide a pilot cutter mounting assembly of the type noted having thrust bearing means disposed between the shaft and the assembly.

A feature of this invention comprises the use of a segmented collar for coupling a cutter support to a cutter shaft. Another feature of this invention comprises the use of collar-mounted jack screws for effecting a disassembly of the collar and cutter support.

Further objects and features of this invention will become more apparent by reference to the following description taken in conjunction with the accompanying figures in which:

FIG. 1 is a partial cross-sectional view of the novel assembly, according to a first embodiment, taken along section 1—1 of FIG. 2;

FIG. 2 is an plan view of the mounting assembly, looking in the direction of the cutters, the cutters however not being shown, the cutter support being shown only in part, and the shaft being cut through; and

FIG. 3 is a side elevation of a portion of a shaft usable in an alternate embodiment of the invention with the same segmented collar of the FIGS. 1 and 2 embodiment.

As shown in FIG. 1 a pilot cutter mounting assembly 10, according to the invention, comprises a collar 12 which couples a cutter support 14 to a cutter shaft 16. A thrust ring 18 which is integral with the cutter shaft 16 engages the collar 12 and receives the thrust developed by the forwardly mounted cutters. Collar 12 has a tapered, external surface 20 and cutter support 14 has a complementary, mating, tapered internal surface 22. Surfaces 20 and 22 are so dimensioned to provide for an interference fit, between cutter support 14 and collar 12, when support 14 is pulled tight onto the collar.

The collar 12 comprises a plurality of members having arcuate cross sections, and in this embodiment, collar 12 comprises two members 24 and 26. Accordingly, members 24 and 26, as is better seen in FIG. 2, substantially define an annulus which envelopes a terminal end of shaft 16. Members 24 and 26 very securely clasp shaft 16 as a consequence of the tight-fitting engagement of support 14 and collar 12. Both members 24 and 26 have an arcuate groove or relieved area 28 (only one of which is shown), formed in the shaft-interfacing surfaces thereof, for nesting ring 18 therewithin. Ring 18 receives and bears the thrust forces developed between support 14 and shaft 16.

Members 24 and 26 have flanges 32 which together define an annular rim 34. Rim 34 is disposed for closing upon a mounting surface 36 presented by cutter support 14 upon interference fitting of support 14 and collar 12. Each flange 32 has at least one bore hole 38, and the support 14 has at least one tapped hole 40 in alignment therewith, holes 38 and 40 being provisioned to receive a stud 42. A locking nut 44, threadedly engaged with stud 42, holds collar 12 and support 14 together. In addition, each flange 32 has at least one tapped hole 46 which receives a screw 50 the jacking end 52 of which screw is disposed for bearing upon mounting surface 36. Finally, the jack screw 50 has a hexagonal head 54 on the ex-

tending end thereof which is turned to cause the jack screw to penetrate the tapped hole 46 and to cause the jacking end 52 to move relative to mounting surface 36. Jack screws 50, therefore, are provided to force cutter support 14 free of collar 12 to enable replacement of the support and the pilot cutters.

A key 56 is disposed within a keyway 58 which is formed in arcuate member 24 and a corresponding keyway 60 formed in shaft 16. This keying arrangement prevents the rotation of the cutter mounting assembly relative to the shaft 16.

To disassemble the mounting assembly, it is only required to remove stud nuts 44 and then turn jack screws 50 to force the support 14 from the collar 12. Thereafter the collar 12 comes free of shaft 16, in that it is segmented. In this embodiment two segments i.e., arcuate members 24 and 26, are shown. However, it will be apparent to those skilled in the art that any plurality of segments can be provisioned to form collar 12 and practice the novel objects of the invention.

The embodiment of my invention exemplified by FIGS 1 and 2 teaches the use of a ring 18' which is integral with the shaft. Of course my invention can be practiced by using a segmented ring, as FIG. 3 illustrates, which is separate from the shaft. A cutter shaft 16', only a portion of which is shown, has an annular groove 30 formed thereabout to receive a segmented thrust ring 18'. Ring 18' comprises a pair of substantially semicircular elements 62 which are interpositioned between shaft 16' and the collar 12 (FIG. 1); elements 62, like ring 18 of the FIGS. 1 and 2 embodiment, nest in the grooves or relieved areas 28 of collar members 24 and 26. Shaft 16', in FIG. 3, is rotated 90° from the disposition of shaft 16 of FIG. 1, whereby it can be seen that the same key 56 is deployed wherewith for engagement with collar 12. Further it can be seen that ends of elements 62 substantially abut key 56. The other ends of elements 62 are behind, and obscured by shaft 16'.

It is possible and feasible to provision a thrust ring similar to that of ring 18' but which is one piece—having but one separation to accommodate for the traverse of the key 56—and which is mounted by spreading thereof (in the same manner as is practiced with piston rings).

Accordingly, while I have described my invention in connection with specific embodiments thereof it is to be clearly understood that this is done only by way of example and not as a limitation to the scope of my invention as set forth in the objects thereof and in the appended claims.

I claim:

1. A pilot cutter mounting assembly comprising:  
a cutter shaft;

a shaft collar engaged around a terminal end of said shaft for coupling a cutter support to the cutter shaft in concentric engagement with said shaft terminal end, said collar having a circumferential flange extending normally from one end thereof with the flanged end of the collar being spaced from said shaft terminal end;

a cutter support in concentric engagement with said collar; means disposed between said shaft and said support for bearing thrust forces which develop between said shaft and said support; and

threaded means operable from the side of said flange distal from said shaft terminal end, said threaded means being engaged only with said flange and said cutter support and being effective both for moving said support out of engagement with said collar, and for freeing said support for removal thereof from said shaft at said terminal end of said shaft by slidable displacement of said support over said collar.

2. The assembly, according to claim 1, wherein:  
said collar has a surface for mounting said support thereto, said surface having dimensions which, relative to complementary mounting surfacing of said support, provides for an interference fit between said support and said collar.

3. The assembly according to claim 1, wherein:  
said support has a tapered surface; and

said collar has a tapered surface for engagement, by an interference fit, with said tapered surface of said support.

4. The assembly, according to claim 1, wherein:

said thrust-forces bearing means engages said collar and is disposed for further engagement with said cutter shaft for securing said collar and said shaft against relative movement therebetween at least along the shaft axis. 5

5. The assembly, according to claim 1, wherein:

said collar comprises a plurality of members of arcuate cross section which members together substantially define an annulus for envelopment of a terminal end of said cutter shaft. 10

6. The assembly, according to claim 5, wherein:

said members each have a relieved area formed therein, radially disposed about the shaft axis, for receiving said thrust-forces bearing means therein. 15

7. The assembly, according to claim 5, wherein:

said thrust-forces bearing means comprises a circular member disposed between said cutter shaft and said arcuate members. 20

8. The assembly, according to claim 5, wherein:

said arcuate members have flanges extending radially relative to the axis of said cutter shaft coupled thereto, which together substantially define an annular rim;

said rim being disposed for closure upon a mounting surface of said cutter support; 25

said flanges each having at least one borehole formed therethrough; and

wherein said collar further includes at least one given, threaded elongate member in penetration of said 30

borehole for replaceable fastening of one end thereof to said mounting surface.

9. The assembly, according to claim 8, wherein:

said flanges have at least one threaded hole formed therethrough; and

said threadedly engaged and threadedly movable means include at least one other, threaded, elongate member in threaded engagement with said threaded hole, one end thereof disposed for establishing adjacency thereof to said mounting surface, and the other end thereof having surfaces engageable by a tool for effecting movement of said one end relative to said mounting surface.

10. The assembly, according to claim 1, wherein:

said collar has means for constraining said collar against rotation relative to said cutter shaft.

11. The assembly, according to claim 5, wherein:

at least one of said arcuate members has a relieved area formed therein, extending in parallelism with said axis, for receiving keying means for constraining said collar against rotation relative to said cutter shaft.

12. The assembly, according to claim 11, wherein:

said relieved area comprises a keyway and said keying means comprises a key nested in said keyway for engagement with a corresponding keyway in said cutter shaft.

13. The assembly, according to claim 9, wherein:

said other member comprises a jack screw operative for effecting said movement, out of engagement, between said collar and cutter support.

35

40

45

50

55

60

65

70

75