



- (51) **International Patent Classification:**
A24F 47/00 (2006.01)
- (21) **International Application Number:**
PCT/US2018/048368
- (22) **International Filing Date:**
28 August 2018 (28.08.2018)
- (25) **Filing Language:** English
- (26) **Publication Language:** English
- (30) **Priority Data:**
62/551,113 28 August 2017 (28.08.2017) US
62/721,512 22 August 2018 (22.08.2018) US
- (71) **Applicant: JUUL LABS, INC.** [US/US]; 560 20th Street, Building 104, San Francisco, CA 94107 (US).
- (72) **Inventors: ATKINS, Ariel;** 560 20th Street, Building 104, San Francisco, CA 94107 (US). **BOWEN, Adam;** 560 20th Street, Building 104, San Francisco, CA 94107 (US).
- LEON DUQUE, Esteban;** 560 20th Street, Building 104, San Francisco, CA 94107 (US).
- (74) **Agent: MOUTON, Nicholas P.** et al.; Mintz Levin Cohn Ferris Glosky and Popeo, P.C., 3580 Carmel Mountain Road, Suite 300, San Diego, California 92130-6768 (US).
- (81) **Designated States** (unless otherwise indicated, for every kind of national protection available): AE, AG, AL, AM, AO, AT, AU, AZ, BA, BB, BG, BH, BN, BR, BW, BY, BZ, CA, CH, CL, CN, CO, CR, CU, CZ, DE, DJ, DK, DM, DO, DZ, EC, EE, EG, ES, FI, GB, GD, GE, GH, GM, GT, HN, HR, HU, ID, IL, IN, IR, IS, JO, JP, KE, KG, KH, KN, KP, KR, KW, KZ, LA, LC, LK, LR, LS, LU, LY, MA, MD, ME, MG, MK, MN, MW, MX, MY, MZ, NA, NG, NI, NO, NZ, OM, PA, PE, PG, PH, PL, PT, QA, RO, RS, RU, RW, SA, SC, SD, SE, SG, SK, SL, SM, ST, SV, SY, TH, TJ, TM, TN, TR, TT, TZ, UA, UG, US, UZ, VC, VN, ZA, ZM, ZW.
- (84) **Designated States** (unless otherwise indicated, for every kind of regional protection available): ARIPO (BW, GH, GM, KE, LR, LS, MW, MZ, NA, RW, SD, SL, ST, SZ, TZ,

(54) **Title:** WICK FOR VAPORIZER DEVICE

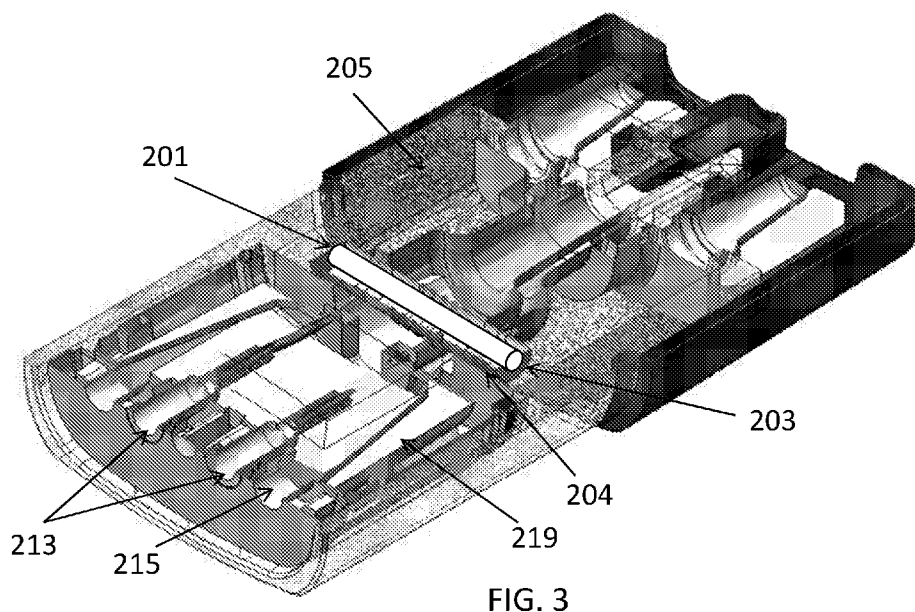

FIG. 3

(57) **Abstract:** A vaporization device includes a wick with improved aerosol production properties relative to a traditional wick, for example one formed of silica fiberglass cord. According to some aspects, the wick is formed of discontinuous fibers that are not packed together and that have varying orientations, creating a plurality of voids, or spaces, between the various fibers and along the length of the wick. This design of voids along the length of the wick allows for rapid wick saturation and air exchange. Because of this, a user can take successive long puffs without noticing much difference in vapor production, as the liquid quickly (e.g., within seconds) replenishes in the wick.



UG, ZM, ZW), Eurasian (AM, AZ, BY, KG, KZ, RU, TJ, TM), European (AL, AT, BE, BG, CH, CY, CZ, DE, DK, EE, ES, FI, FR, GB, GR, HR, HU, IE, IS, IT, LT, LU, LV, MC, MK, MT, NL, NO, PL, PT, RO, RS, SE, SI, SK, SM, TR), OAPI (BF, BJ, CF, CG, CI, CM, GA, GN, GQ, GW, KM, ML, MR, NE, SN, TD, TG).

Published:

— *with international search report (Art. 21(3))*

WICK FOR VAPORIZER DEVICE

CROSS REFERENCE TO RELATED APPLICATIONS

[0001] This application claims priority to U.S. provisional application no.: 62/551,113, titled “WICK FOR VAPORIZER DEVICE,” filed on August 28, 2017, and U.S. provisional application no.: 62/721,512, titled “WICK FOR VAPORIZER DEVICE,” filed on August 22, 2018, the contents of which are fully incorporated by reference.

BACKGROUND

[0002] Vaporizing devices, including electronic vaporizers or e-vaporizer devices, allow the delivery of vapor containing one or more active ingredients by inhalation of the vapor. Electronic vaporizer devices are gaining increasing popularity both for prescriptive medical use, in delivering medicaments, and for consumption of tobacco or other plant-based smokeable materials, including solid (e.g., loose-leaf) materials, solid/liquid (e.g., suspensions, liquid-coated) materials, wax extracts, and prefilled pods (e.g., cartridges, wrapped containers, and/or the like) of such materials. Electronic vaporizer devices in particular may be portable, self-contained, and/or convenient for use.

[0003] Electronic vaporizers may use an atomizer system that includes a wicking element with a resistive heating element, such as a coil wrapped around the wicking element or positioned within a hollowed wicking element.

[0004] Vaporizer devices can utilize a wick formed of a silica or cotton material. Silica wick material can be formed by bundling together fine, continuous filaments of silica glass into threads, which are then bundled together to form a cord or rope used as the wick. The cord may be specified by a nominal outer diameter, number of threads, and/or a TEX value indicating a linear density. TEX is, in accordance with implementations described here, a unit of weight used to measure the density of yarns, equal to 1 gram per 1000 meters.

[0005] Atomizer systems in which liquid is drawn into the wick from a reservoir are limited in that the liquid is drawn in longitudinally at end points of the silica cord (e.g., at end points of the continuous filaments of silica). This design suffers from a timing standpoint, as during use of a vaporizer device, liquid may not be replenished as quickly as desired for a user as the liquid evaporates from a heated region of the wick and more liquid needs to travel along the length of the wick for replenishment.

SUMMARY

[0006] Aspects of the current subject matter relate to a wick, for a vaporization device, formed of one or more materials, such as glass, cotton, and/or or the like, or a combination thereof. In particular, the wick can have a plurality of voids along its length for use in a vaporizer device.

[0007] In some implementations, a cartridge for a vaporization device can comprise a mouthpiece, a tank configured to hold a vaporizable material, a wick configured to draw the vaporizable material from the tank to a vaporization region, and a heating element disposed near the vaporization region. The wick can have a length and one more voids along the length. The heating element can be configured to heat the vaporizable material drawn from the tank by the wick.

[0008] In some related implementations, the heating element can at least partially encircle at least a portion of the wick, the wick can comprise a plurality of discontinuous glass filaments, the wick can comprise a heat-vaporizable coating, the heating element can be disposed between a pair of plates, the mouthpiece can be disposed at a first end of a body of the cartridge, and/or the heating element can be disposed at a second end of the body that is opposite the first end.

[0009] In other related implementations, the cartridge can further comprise an air inlet passage. The air inlet passage can be configured to direct a flow of air over the wick such

that when the heating element is activated, the vaporizable material drawn by the wick into the vaporization region is evaporated into the flow of air. In some aspects, the wick and the heating element can be configured to cause aerosolization of the vaporizable material.

[0010] In other related implementations, the wick can comprise a glass wick. The glass wick can be characterized by a TEX value that is between 400 and 1000, between 500 and 900, between 600 and 800, between 600 and 700, between 640 and 680, and/or between 650 and 670. The glass wick can be characterized by a TEX value that is 660, approximately 660, or near 660.

[0011] In other related implementations, the wick can be characterized by at least a 10% volume of void spaces to the total volume of the wick or at least a 5% volume of void spaces to the total volume of the wick.

[0012] In other related implementations, the cartridge may not be present and the vaporization device may instead include the tank configured to hold the vaporizable material, the wick configured to draw the vaporizable material from the tank to the vaporization region, and/or the heating element disposed near the vaporization region.

[0013] In some implementations, a vaporization device can comprise a tank configured to hold a vaporizable material, a wick configured to draw the vaporizable material from the tank to a vaporization region, and/or a heating element disposed near the vaporization region. The wick can have a length and one or more fibers. The heating element can be configured to generate heat, a portion of the heat being transferred to the vaporizable material to aerosolize the vaporizable material.

[0014] In some related implementations, the wick can include an inner wick material and/or an outer jacket that at least partially surrounds the inner wick material. The inner wick material can comprise a glass material and/or the outer jacket can comprise a cotton material, a hemp material, another fibrous material, and/or the like. The inner wick material can be

characterized by a TEX value that is between 400 and 1000, between 500 and 900, between 600 and 800, and/or between 600 and 700, between 640 and 680, and/or between 650 and 670. The inner wick material can be characterized by a TEX value that is 660, approximately 660, or near 660.

[0015] In other related implementations, the inner wick can be characterized by at least a 10% volume of void spaces to the total volume of the inner wick or at least a 5% volume of void spaces to the total volume of the inner wick.

[0016] In other related implementations, the heating element can at least partially encircle at least a portion of the wick, the inner wick material can comprise a plurality of discontinuous glass filaments, the wick can comprise a heat-vaporizable coating, and/or the heating element can be disposed between a pair of plates.

[0017] In other related implementations, the vaporization device can further comprise an air inlet passage. The air inlet passage can be configured to direct a flow of air over the wick such that when the heating element is activated, the vaporizable material drawn by the wick into the vaporization region is evaporated into the flow of air. In some aspects, the wick and the heating element can be configured to cause aerosolization of the vaporizable material.

[0018] In other related implementations, the vaporization device can comprise a cartridge comprising the tank configured to hold a vaporizable material, the wick configured to draw the vaporizable material from the tank to a vaporization region, and/or the heating element disposed near the vaporization region. In some aspects, a mouthpiece can be disposed at a first end of a body of the cartridge and/or the heating element can be disposed at a second end of the body that is opposite the first end.

[0019] In some implementations, a method of providing a vapor and/or aerosol for inhalation by a user can include drawing, through a wick, a vaporizable material from a tank of a vaporization device to a vaporization region, the wick having a plurality of voids along

its length. The method can further include heating the vaporization region with a heating element disposed near the vaporization region to cause vaporization of the vaporizable material. The method can further include causing the vaporized vaporizable material to be entrained in a flow of air to a mouthpiece of the vaporization device. In some aspects, the vaporization device can include the vaporization device and/or cartridge described in any of the implementations described herein.

BRIEF DESCRIPTION OF THE DRAWINGS

[0020] The accompanying drawings, which are incorporated in and constitute a part of this specification, show certain aspects of the subject matter disclosed herein and, together with the description, help explain some of the principles associated with the disclosed implementations. In the drawings:

[0021] FIG. 1 illustrates, via a graph, experimental results comparing mass removal properties of a glass wick, consistent with implementations of the current subject matter, in a vaporizer device to that of a silica cord wick in a vaporizer device;

[0022] FIG. 2 illustrates, via a perspective view, a cartridge in which a wick consistent with implementations of the current subject matter may be incorporated;

[0023] FIG. 3 illustrates, via a cross-sectional view, the cartridge of FIG. 2, showing the wick and internal resistive heating components; and

[0024] FIG. 4 shows a process flow chart illustrating features of a method of drawing a vaporizable material and causing vaporization of the vaporizable material in a vaporization device consistent with implementations of the current subject matter.

DETAILED DESCRIPTION

[0025] Implementations of the current subject matter include devices relating to vaporizing of one or more materials for inhalation by a user. The term “vaporizer” is used

generically in the following description and refers to a vaporizer device. Examples of vaporizers consistent with implementations of the current subject matter include electronic vaporizers, electronic cigarettes, e-cigarettes, and/or the like. In general, such vaporizers can be portable and/or hand-held devices that heat a vaporizable material to provide an inhalable dose of the material.

[0026] Electronic vaporizers can use an atomizer system that includes a wicking element (or wick) with a resistive heating element such as a coil wrapped around the wicking element or positioned within a hollow wicking element. Other wick configurations are also possible, as discussed further below. The wick serves at least two purposes: to draw liquid from a reservoir to the atomizer where it can be vaporized by the coil; and to allow air to enter the reservoir to replace the volume of liquid removed. When a user inhales on the vaporizer, the coil heater may be activated, and incoming may air pass over the saturated wick/coil assembly, stripping off vapor, which condenses and enters the user's lungs. During and/or after the puff, capillary action pulls more liquid into the wick and air returns to the reservoir through the wick.

[0027] A vaporizer consistent with implementations of the current subject matter can include a wick having a plurality of voids along its length. The wick according to some implementations of the current subject matter may be a glass wick formed of discontinuous glass fibers that are finite in length and/or spun together to form a yarn. In some aspects, the discontinuous glass fibers making up the wick are not packed together and have varying orientations, creating a plurality of voids, or spaces, between the various fibers and along the length of the wick. This design of voids along the length of the wick results in improved aerosol production properties relative to a traditional wick, for example one formed of silica fiberglass cord, by maintaining more liquid per unit volume in close proximity to the evaporation surface. During a puff, this liquid need only wick radially (or in a direction

orthogonal to the evaporator surface). Between puffs, more time is available for this liquid to be replenished axially. Because of this, the mass density for a given puff can be higher than an equivalent design with a more conventional, corded wick.

[0028] A wick consistent with implementations of the current subject matter has increased liquid-carrying capacity, while also being thermally stable and having sufficient structural integrity for its use in vaporizer devices.

[0029] A wick consistent with implementations of the current subject matter may have a TEX value from between about 400 to about 1,000, preferably between about 600 to about 800. In some implementations, the wick has a TEX value of 660. Other TEX values may be used. A glass wick consistent with implementations of the current subject matter may be a Decofil C-Glass Staple Fiber Yarn, such as Decofil CD 11.5 660 L01P A1 or the like, which may be from another manufacturer. The wick may be formed of continuous or discontinuous C-Glass filaments, brought together to form a sliver, a yarn, and/or the like.

[0030] According to some aspects of the current subject matter, materials other than discontinuous glass fibers may be used to form a wick with voids along its length to allow for replenishment of liquid radially (or in a direction orthogonal to the evaporator surface) and axially along the wick. For example, a porous material, such as a ceramic material, having a plurality of voids or spaces along its length may be used as a suitable wicking material for the wick. Alternatively, other materials or fibers that are finite in length and that can be spun together to form a yarn, or other structure having voids along its length, may be used as a suitable wicking material. Such materials may be characterized by, for example, at least a 10% volume of void spaces to the total volume of the wick. According to additional aspects of the current subject matter, a suitable wicking material is characterized by at least a 5% volume of void spaces to the total volume of the wick.

[0031] The use of a wick having features consistent with implementations of the current subject matter in a vaporizer device produces unexpected results. This is because the wicking performance of a glass material is worse in terms of capillary pressure as compared to more traditional, more porous wick materials (e.g., silica or cotton). However, by utilizing a wick having features consistent with implementations of the current subject matter, the aerosol density produced by the atomizer is improved, intra-puff, which is a result of the atomizer layout. As liquid has to traverse a long distance longitudinally from the reservoir, replenishment can easily become the rate-limiting step for aerosol production, no matter the capillary pressure. Thus, by incorporating a wick having a plurality of voids along its length, as described herein, there is an increased amount of liquid near the evaporator surface at the beginning of a puff, resulting in improved aerosol density.

[0032] A glass wick having features consistent with implementations of the current subject matter was compared with a reference silica cord wick to demonstrate the mass removal properties of the glass wick. The glass wick used was the Decofil CD 11.5 660 L01P A1 with a TEX value of 660. The reference silica cord wick used had eight strands, a diameter of 1.5mm, a TEX value of 1450, and a twist value of 120°. A smoking machine was used with three replicates of each configuration of a vaporizer device with a glass wick and a vaporizer device with a reference silica cord wick (e.g., six device and cartridge combinations total). A standardized puff profile of 100cc puff volume, 3s puff duration, and 30s inter-puff interval was utilized. Puffs were taken in 10-puff bouts. An initial weight of each vaporizer device and cartridge was taken, and the weight was taken again following each bout. Results are shown in the graph 100 of FIG. 1, which illustrates average mass lost for each configuration (data 110 for the glass wick configuration, data 120 for the reference silica cord wick configuration), for each successive bout. As can be seen in the graph 100, the glass

wick is able to better replenish its liquid carrying capacity between puffs when compared to the reference silica cord wick as more mass is removed in the glass wick after each puff bout.

[0033] In some implementations, a wick can be formed of a combination of glass and another natural fibrous material, such as cotton, hemp, or the like. In some implementations, the wick can include an inner wick material and at least one outer jacket. In some exemplary implementations, the wick can include two or more outer jackets.

[0034] The inner wick material can be formed as a continuous or discontinuous thread, yarn or another strand configuration. The outer jacket can have a series of interlocking loops of material, or can be formed of a combination of solid tube-like material and/or porous tube or matrix of cross-stitched material. For instance, the inner wick material can be formed of glass, which can be continuous or discontinuous, and which inner wick material can be formed of one or more strands wound or provided together. In some implementations, inner wick material can include a glass wick having features consistent with implementations described herein. The outer jacket can be of a different material from the inner wick material and/or include a fibrous material, such as cotton, hemp, and/or the like. The outer jacket can be formed as a continuous sheath, can be formed as a matrix of cross-strands (e.g., knitted and/or the like), or any other formation.

[0035] In other implementations, the wick can include an inner wick material of a fibrous material, such as cotton, where the fibrous material can be continuous, such as a yarn or weave of one or more strands, or discontinuous, with one or more gaps along its length or along the length of one or more strands that make up the inner wick material. The wick can include an outer jacket made of glass or other rigid or semi-rigid, brittle yet porous material, such as glass.

[0036] In yet other implementations, in a configuration having an inner wick material and at least one outer jacket, either the inner wick material or at least one outer jacket can include

detents, apertures, holes, separations, or the like, and which can be microscopic in size. Each of the inner wick material or the outer jacket can be embedded with additional materials to improve wicking and holding of a fluid to be vaporized.

[0037] FIGS. 2 and 3 illustrate an example of a cartridge 200 that may include or be adapted to include a wick consistent with implementations of the current subject matter. The cartridge 200 may be used with a vaporizer body (not shown) having a battery and control circuitry, together configured to generate an inhalable vapor by heating a vaporizable material before and/or as it enters a wick from which it can be vaporized.

[0038] In the example configuration shown in FIGS. 2 and 3, the cartridge 200 includes a tank (or reservoir) 205 for holding a vaporizable material (such as an oil or some other fluid or liquid), a proximal mouthpiece 209, a set of pin connectors 213 at the distal end, and openings 215 into an overflow leak chamber 216 (which may include one or more absorbent pads 219 for soaking up leakage of the vaporizable material as shown in FIG. 3), as well as a wick 203 consistent with implementations of the current subject matter. The wick 203 may be wrapped with a resistive heating element (coil 204), as shown in FIG. 3, which is connected by plates 201 to pin inputs. A heater may include the wick 203 extending between plates 201 and the heating element 204 in contact with both the plates 201 and the wick 203.

[0039] Air may be drawn in from the bottom or base of the cartridge 200, pulled over and around the heating element 204. An air path through the cartridge 200 passes through the tank 205. A heating chamber, holding the wick 203 and heating element 204, may be an internal chamber (e.g., surrounded by the tank) through which the airflow passes. The wick 203 may be suspended between a pair of heater contacts positioned in the heating chamber.

[0040] The wick 203 draws vaporizable material from the tank 205, from both ends of the wick 203 and radially along the length of the wick 203 due to the plurality of voids within the wick 203. When a user puffs on the cartridge 200, air flows into an inlet. Simultaneously,

the heating element 204 may be activated, e.g., by a pressure sensor, pushbutton, motion sensor, flow sensor, or other approach capable of detecting that a user is taking a puff or otherwise inhaling through a flow path of the vaporizer device. When the heating element 204 is activated, the coil may have a temperature increase as a result of current flowing through the coil to generate heat. The heat is transferred to at least a portion of the vaporizable material in the tank 205 through conductive, convective, and/or radiative heat transfer such that at least a portion of the vaporizable material vaporizes. The incoming air into the vaporizer device flows over the heated wick/coil, stripping away the vaporized vaporizable material, where it is condensed and exits as an aerosol via the mouthpiece 209 to a user.

[0041] A wick 203 consistent with implementations of the current subject matter can provide a capillary pathway, for vaporizable material within the tank 205, through and into the wick 203. The capillary pathway is generally large enough to permit wicking to replace vaporized liquid transferred from the tank 205 by capillary action (wicking) during use of the vaporizer device, but may be small enough to prevent leakage of the vaporizable fluid material out of the cartridge 200 during normal operation, including when applying pressure to (e.g., squeezing) the cartridge 200. An external portion of the wick 203 may include a wick housing. The wick housing and/or wick 203 may be treated to prevent leakage. For example, the wick 203 and/or wick housing may be coated after filling to prevent leakage and/or evaporation through the wick 203 until activated by connecting to a vaporizer body and/or applying current through electrical contacts (e.g., operation in a vaporizer device), or otherwise using the cartridge 200. Any appropriate coating may be used, including a heat-vaporizable coating (e.g., a wax or other material) or the like.

[0042] A wick consistent with implementations of the current subject matter may have an orientation other than that shown in the exemplary cartridge illustrations of FIGs. 2 and 3.

For example, the wick 203 shown in FIG. 3 extends horizontally between two side portions of the cartridge 200. However, the wick is not limited to this orientation and may, for example, extend internally along a length of the body of the cartridge 200 with the heating element at one end of the wick. Other orientations and configurations are also possible.

[0043] Although the example described herein with respect to FIGs. 2 and 3 is directed to a vaporizer that utilizes a removable cartridge, a wick consistent with implementations of the current subject matter is not limited to such a device configuration. For example, a wick may be incorporated as part of a vaporizer device that includes a reservoir in which the wick and the heating element are included or in contact with.

[0044] With reference to FIG. 4, a process flow chart 400 illustrates features of a method, which may optionally include some or all of the following. At 410, a vaporizable material is drawn, through a wick, from a tank of a vaporization device to a vaporization region. At 420, the vaporization region is heated with a heating element disposed near the vaporization region. The heating causes vaporization of the vaporizable material in the vaporization region. At 430, the vaporized vaporizable material is entrained in a flow of air to a mouthpiece of the vaporization device.

[0045] When a feature or element is herein referred to as being “on” another feature or element, it can be directly on the other feature or element or intervening features and/or elements may also be present. In contrast, when a feature or element is referred to as being “directly on” another feature or element, there are no intervening features or elements present. It will also be understood that, when a feature or element is referred to as being “connected”, “attached” or “coupled” to another feature or element, it can be directly connected, attached or coupled to the other feature or element or intervening features or elements may be present. In contrast, when a feature or element is referred to as being

“directly connected”, “directly attached” or “directly coupled” to another feature or element, there are no intervening features or elements present.

[0046] Although described or shown with respect to one embodiment, the features and elements so described or shown can apply to other embodiments. It will also be appreciated by those of skill in the art that references to a structure or feature that is disposed “adjacent” another feature may have portions that overlap or underlie the adjacent feature.

[0047] Terminology used herein is for the purpose of describing particular embodiments and implementations only and is not intended to be limiting. For example, as used herein, the singular forms “a”, “an” and “the” are intended to include the plural forms as well, unless the context clearly indicates otherwise. It will be further understood that the terms “comprises” and/or “comprising,” when used in this specification, specify the presence of stated features, steps, operations, elements, and/or components, but do not preclude the presence or addition of one or more other features, steps, operations, elements, components, and/or groups thereof. As used herein, the term “and/or” includes any and all combinations of one or more of the associated listed items and may be abbreviated as “/”.

[0048] In the descriptions above and in the claims, phrases such as “at least one of” or “one or more of” may occur followed by a conjunctive list of elements or features. The term “and/or” may also occur in a list of two or more elements or features. Unless otherwise implicitly or explicitly contradicted by the context in which it used, such a phrase is intended to mean any of the listed elements or features individually or any of the recited elements or features in combination with any of the other recited elements or features. For example, the phrases “at least one of A and B;” “one or more of A and B;” and “A and/or B” are each intended to mean “A alone, B alone, or A and B together.” A similar interpretation is also intended for lists including three or more items. For example, the phrases “at least one of A, B, and C;” “one or more of A, B, and C;” and “A, B, and/or C” are each intended to mean “A

alone, B alone, C alone, A and B together, A and C together, B and C together, or A and B and C together.” Use of the term “based on,” above and in the claims is intended to mean, “based at least in part on,” such that an unrecited feature or element is also permissible.

[0049] Spatially relative terms, such as “under”, “below”, “lower”, “over”, “upper” and the like, may be used herein for ease of description to describe one element or feature’s relationship to another element(s) or feature(s) as illustrated in the figures. It will be understood that the spatially relative terms are intended to encompass different orientations of the device in use or operation in addition to the orientation depicted in the figures. For example, if a device in the figures is inverted, elements described as “under” or “beneath” other elements or features would then be oriented “over” the other elements or features. Thus, the exemplary term “under” can encompass both an orientation of over and under. The device may be otherwise oriented (rotated 90 degrees or at other orientations) and the spatially relative descriptors used herein interpreted accordingly. Similarly, the terms “upwardly”, “downwardly”, “vertical”, “horizontal” and the like are used herein for the purpose of explanation only unless specifically indicated otherwise.

[0050] Although the terms “first” and “second” may be used herein to describe various features/elements (including steps), these features/elements should not be limited by these terms, unless the context indicates otherwise. These terms may be used to distinguish one feature/element from another feature/element. Thus, a first feature/element discussed below could be termed a second feature/element, and similarly, a second feature/element discussed below could be termed a first feature/element without departing from the teachings provided herein.

[0051] As used herein in the specification and claims, including as used in the examples and unless otherwise expressly specified, all numbers may be read as if prefaced by the word “about” or “approximately,” even if the term does not expressly appear. The phrase “about”

or “approximately” may be used when describing magnitude and/or position to indicate that the value and/or position described is within a reasonable expected range of values and/or positions. For example, a numeric value may have a value that is +/- 0.1% of the stated value (or range of values), +/- 1% of the stated value (or range of values), +/- 2% of the stated value (or range of values), +/- 5% of the stated value (or range of values), +/- 10% of the stated value (or range of values), etc. Any numerical values given herein should also be understood to include about or approximately that value, unless the context indicates otherwise. For example, if the value “10” is disclosed, then “about 10” is also disclosed. Any numerical range recited herein is intended to include all sub-ranges subsumed therein. It is also understood that when a value is disclosed that “less than or equal to” the value, “greater than or equal to the value” and possible ranges between values are also disclosed, as appropriately understood by the skilled artisan. For example, if the value “X” is disclosed the “less than or equal to X” as well as “greater than or equal to X” (e.g., where X is a numerical value) is also disclosed. It is also understood that the throughout the application, data is provided in a number of different formats, and that this data, represents endpoints and starting points, and ranges for any combination of the data points. For example, if a particular data point “10” and a particular data point “15” are disclosed, it is understood that greater than, greater than or equal to, less than, less than or equal to, and equal to 10 and 15 are considered disclosed as well as between 10 and 15. It is also understood that each unit between two particular units are also disclosed. For example, if 10 and 15 are disclosed, then 11, 12, 13, and 14 are also disclosed.

[0052] Although various illustrative embodiments are described above, any of a number of changes may be made to various embodiments without departing from the teachings herein. For example, the order in which various described method steps are performed may often be changed in alternative embodiments, and in other alternative embodiments one or

more method steps may be skipped altogether. Optional features of various device and system embodiments may be included in some embodiments and not in others. Therefore, the foregoing description is provided primarily for exemplary purposes and should not be interpreted to limit the scope of the claims.

[0053] The examples and illustrations included herein show, by way of illustration and not of limitation, specific embodiments in which the subject matter may be practiced. As mentioned, other embodiments may be utilized and derived there from, such that structural and logical substitutions and changes may be made without departing from the scope of this disclosure. Such embodiments of the inventive subject matter may be referred to herein individually or collectively by the term “invention” merely for convenience and without intending to voluntarily limit the scope of this application to any single invention or inventive concept, if more than one is, in fact, disclosed. Thus, although specific embodiments have been illustrated and described herein, any arrangement calculated to achieve the same purpose may be substituted for the specific embodiments shown. This disclosure is intended to cover any and all adaptations or variations of various embodiments. Combinations of the above embodiments, and other embodiments not specifically described herein, will be apparent to those of skill in the art upon reviewing the above description.

CLAIMS

What is claimed is:

1. A cartridge for a vaporization device, the cartridge comprising:
 - a mouthpiece;
 - a tank configured to hold a vaporizable material;
 - a wick configured to draw the vaporizable material from the tank to a vaporization region, the wick having a length and having one more voids along the length; and
 - a heating element disposed near the vaporization region and configured to heat the vaporizable material drawn from the tank by the wick.
2. The cartridge of claim 1, wherein the heating element at least partially encircles at least a portion of the wick.
3. The cartridge of claim 1, further comprising an air inlet passage.
4. The cartridge of claim 3, wherein the air inlet passage is configured to direct a flow of air over the wick such that when the heating element is activated, the vaporizable material drawn by the wick into the vaporization region is evaporated into the flow of air.
5. The cartridge of claim 4, wherein the wick and the heating element are configured to cause aerosolization of the vaporizable material.
6. The cartridge of claim 1, wherein the wick comprises a glass wick.
7. The cartridge of claim 6, wherein the glass wick is characterized by a TEX value of between 400 and 1000.

8. The cartridge of claim 6, wherein the glass wick is characterized by a TEX value of 660.

9. The cartridge of claim 1, wherein the wick comprises a plurality of discontinuous glass filaments.

10. The cartridge of claim 1, wherein the wick comprises a heat-vaporizable coating.

11. The cartridge of claim 1, wherein the heating element is disposed between a pair of plates.

12. The cartridge of claim 1, wherein the mouthpiece is disposed at a first end of a body of the cartridge and the heating element is disposed at a second end of the body, opposite the first end.

13. A vaporization device comprising:

a tank configured to hold a vaporizable material;

a wick configured to draw the vaporizable material from the tank to a vaporization region, the wick having a length and being formed of one or more fibers;
and

a heating element disposed near the vaporization region, the heating element configured to generate heat, a portion of the heat being transferred to the vaporizable material to aerosolize the vaporizable material.

14. The vaporization device in accordance with claim 13, wherein the wick includes an inner wick material and an outer jacket that at least partially surrounds the inner wick material.

15. A method comprising:

drawing, through a wick, a vaporizable material from a tank of a vaporization device to a vaporization region, the wick having a plurality of voids along its length;

heating the vaporization region with a heating element disposed near the vaporization region to cause vaporization of the vaporizable material; and

causing the vaporized vaporizable material to be entrained in a flow of air to a mouthpiece of the vaporization device.

100

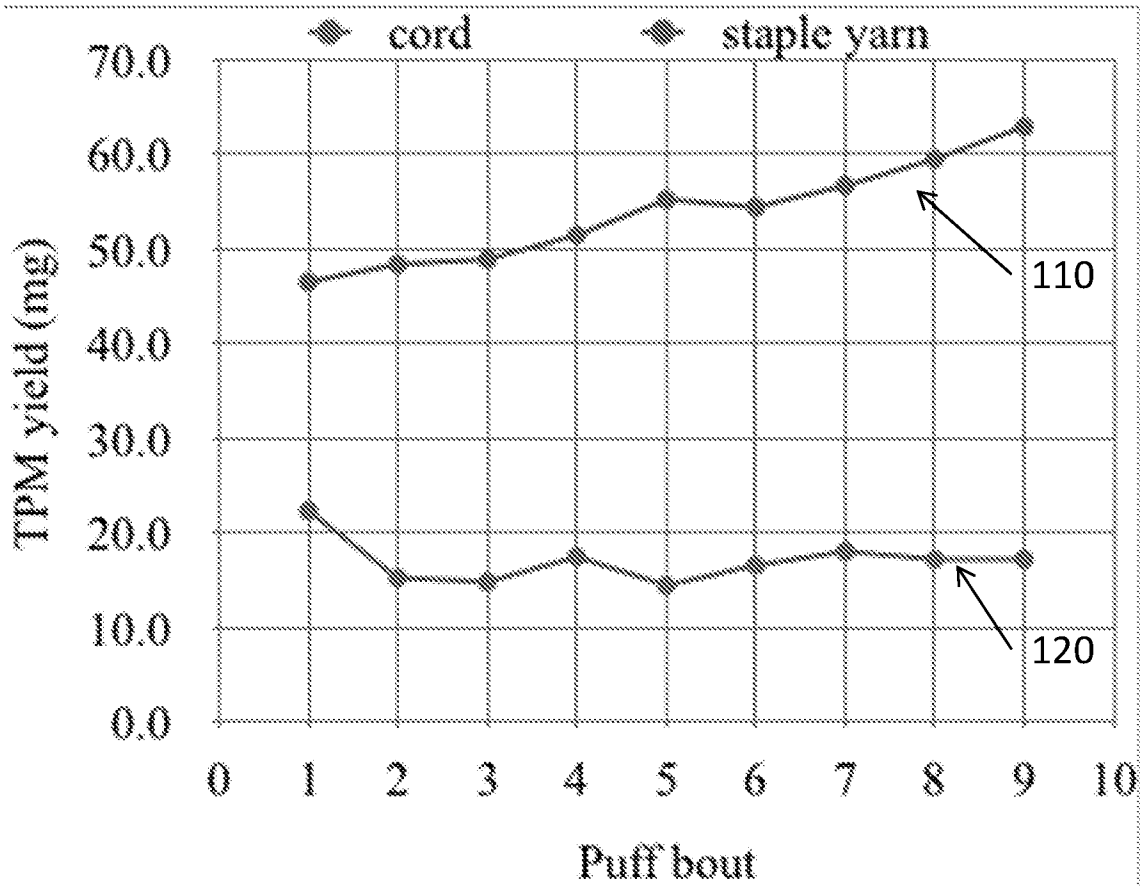
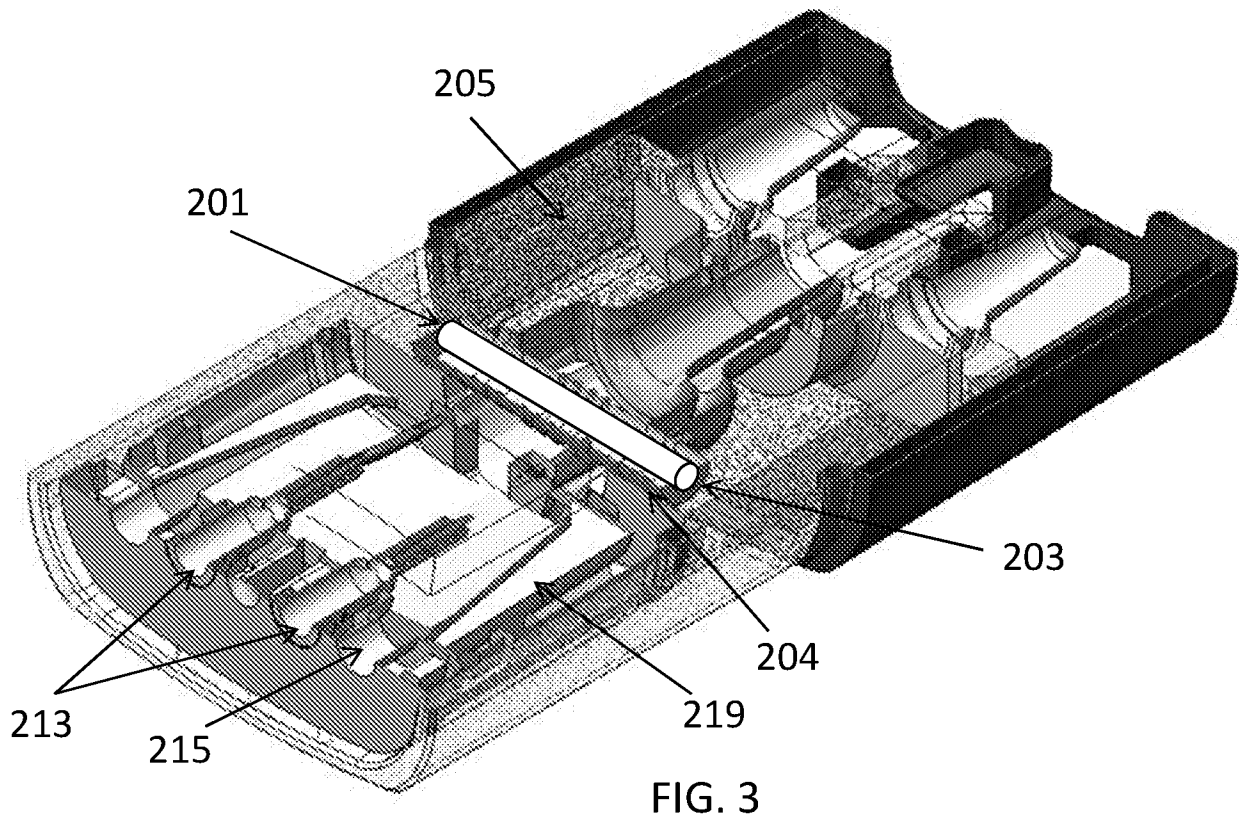
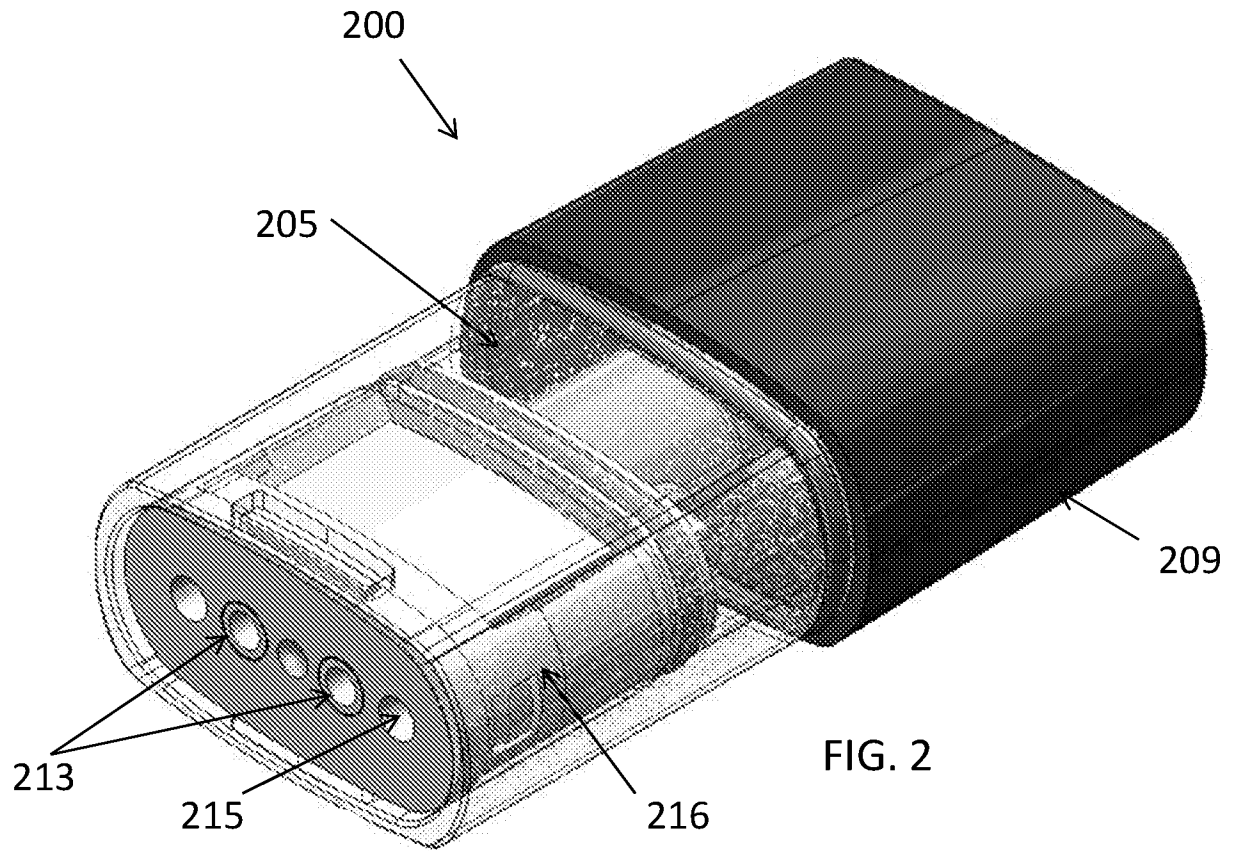

FIG. 1



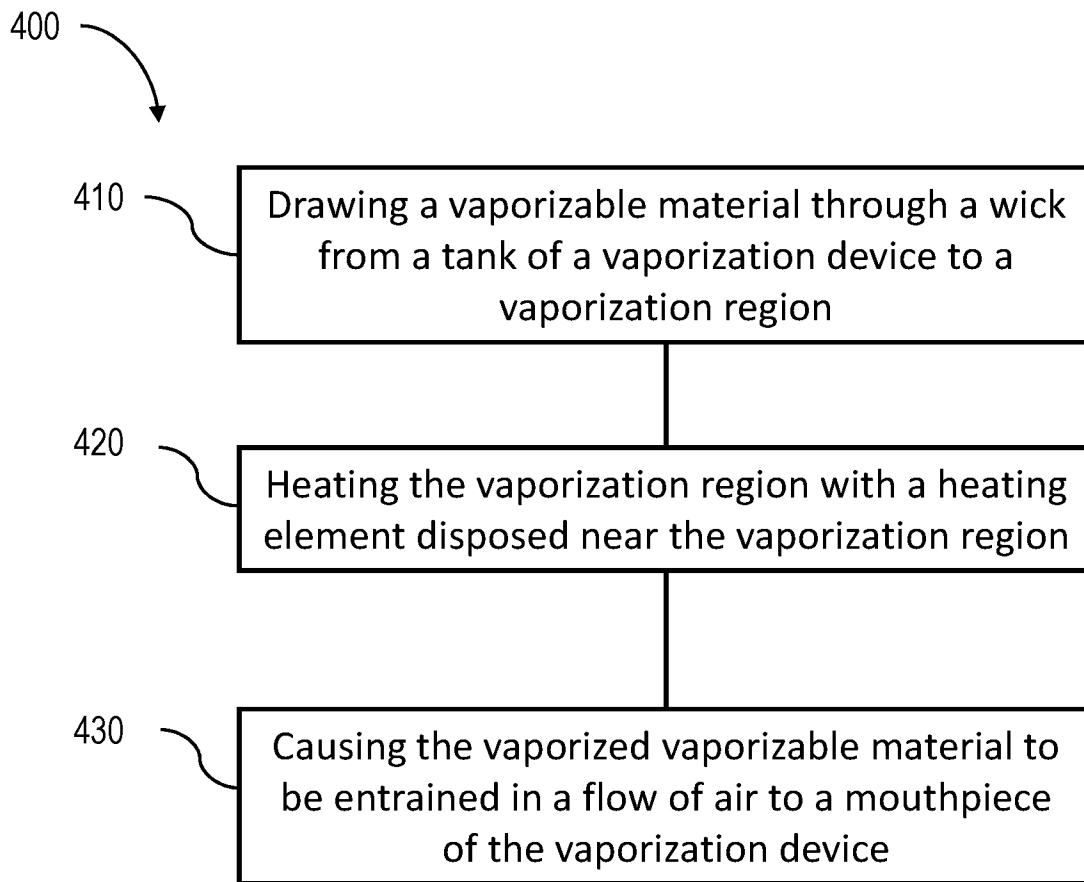

FIG. 4

INTERNATIONAL SEARCH REPORT

International application No
PCT/US2018/048368

A. CLASSIFICATION OF SUBJECT MATTER
INV. A24F47/00
ADD.

According to International Patent Classification (IPC) or to both national classification and IPC

B. FIELDS SEARCHED
Minimum documentation searched (classification system followed by classification symbols)
A24F A61M

Documentation searched other than minimum documentation to the extent that such documents are included in the fields searched

Electronic data base consulted during the international search (name of data base and, where practicable, search terms used)
EPO-Internal, WPI Data

C. DOCUMENTS CONSIDERED TO BE RELEVANT

Category*	Citation of document, with indication, where appropriate, of the relevant passages	Relevant to claim No.
X	WO 2014/159982 A1 (REYNOLDS TOBACCO CO R [US]) 2 October 2014 (2014-10-02)	1-9, 11-14
Y	passages of the description relating to figure 1; figure 1 page 3 page 11 - page 12 page 27 - page 28 page 31 - page 32	10
A	----- GB 2 504 076 A (NICOVENTURES HOLDINGS LTD [GB]) 22 January 2014 (2014-01-22) figure 7 page 7, line 33 - page 8, line 9	1
Y	----- US 2016/374399 A1 (MONSEES JAMES [US] ET AL) 29 December 2016 (2016-12-29) paragraph [0346]	10
	----- -/--	

Further documents are listed in the continuation of Box C.

See patent family annex.

* Special categories of cited documents :

- "A" document defining the general state of the art which is not considered to be of particular relevance
- "E" earlier application or patent but published on or after the international filing date
- "L" document which may throw doubts on priority claim(s) or which is cited to establish the publication date of another citation or other special reason (as specified)
- "O" document referring to an oral disclosure, use, exhibition or other means
- "P" document published prior to the international filing date but later than the priority date claimed

"T" later document published after the international filing date or priority date and not in conflict with the application but cited to understand the principle or theory underlying the invention

"X" document of particular relevance; the claimed invention cannot be considered novel or cannot be considered to involve an inventive step when the document is taken alone

"Y" document of particular relevance; the claimed invention cannot be considered to involve an inventive step when the document is combined with one or more other such documents, such combination being obvious to a person skilled in the art

"&" document member of the same patent family

Date of the actual completion of the international search

16 November 2018

Date of mailing of the international search report

23/11/2018

Name and mailing address of the ISA/

European Patent Office, P.B. 5818 Patentlaan 2
NL - 2280 HV Rijswijk
Tel. (+31-70) 340-2040,
Fax: (+31-70) 340-3016

Authorized officer

Cecchini, Stefano

INTERNATIONAL SEARCH REPORT

International application No
PCT/US2018/048368

C(Continuation). DOCUMENTS CONSIDERED TO BE RELEVANT

Category*	Citation of document, with indication, where appropriate, of the relevant passages	Relevant to claim No.
X,P	WO 2018/125934 A1 (JUUL LABS INC [US]) 5 July 2018 (2018-07-05) the whole document -----	1-14

INTERNATIONAL SEARCH REPORT

International application No.
PCT/US2018/048368

Box No. II Observations where certain claims were found unsearchable (Continuation of item 2 of first sheet)

This international search report has not been established in respect of certain claims under Article 17(2)(a) for the following reasons:

1. Claims Nos.: 15
because they relate to subject matter not required to be searched by this Authority, namely:
see FURTHER INFORMATION sheet PCT/ISA/210

2. Claims Nos.:
because they relate to parts of the international application that do not comply with the prescribed requirements to such an extent that no meaningful international search can be carried out, specifically:

3. Claims Nos.:
because they are dependent claims and are not drafted in accordance with the second and third sentences of Rule 6.4(a).

Box No. III Observations where unity of invention is lacking (Continuation of item 3 of first sheet)

This International Searching Authority found multiple inventions in this international application, as follows:

1. As all required additional search fees were timely paid by the applicant, this international search report covers all searchable claims.

2. As all searchable claims could be searched without effort justifying an additional fees, this Authority did not invite payment of additional fees.

3. As only some of the required additional search fees were timely paid by the applicant, this international search report covers only those claims for which fees were paid, specifically claims Nos.:

4. No required additional search fees were timely paid by the applicant. Consequently, this international search report is restricted to the invention first mentioned in the claims; it is covered by claims Nos.:

Remark on Protest

- The additional search fees were accompanied by the applicant's protest and, where applicable, the payment of a protest fee.
- The additional search fees were accompanied by the applicant's protest but the applicable protest fee was not paid within the time limit specified in the invitation.
- No protest accompanied the payment of additional search fees.

FURTHER INFORMATION CONTINUED FROM PCT/ISA/ 210

Continuation of Box II.1

Claims Nos.: 15

Claim 15 defines a method comprising the step of "causing the vaporized vaporizable material to be entrained in a flow of air to a mouthpiece of the vaporization device". This step encompasses the generation of said flow of air by a user puffing at the mouthpiece (see par. [0019], [0026] and [0040]). This makes the vaporized material enter the user's lungs, thereby generating a physiological effect. Thus, the subject-matter of claim 15 is regarded as a method for treatment of the human or animal body by therapy (Rule 39.1 (iv) PCT). Consequently, the subject-matter of claim 15 has not been searched and will not be examined (Rule 66.1(e) PCT, Rule 67.1(iv) PCT).

INTERNATIONAL SEARCH REPORT

Information on patent family members

International application No

PCT/US2018/048368

Patent document cited in search report	Publication date	Patent family member(s)	Publication date	
WO 2014159982	A1	02-10-2014	CN 105188430 A	23-12-2015
			EP 2967147 A1	20-01-2016
			HK 1220091 A1	28-04-2017
			JP 2016512033 A	25-04-2016
			KR 20150130457 A	23-11-2015
			RU 2015139069 A	17-04-2017
			US 2014261487 A1	18-09-2014
			WO 2014159982 A1	02-10-2014

GB 2504076	A	22-01-2014	AU 2013292106 A1	05-02-2015
			BR 112015000968 A2	22-05-2018
			CA 2878973 A1	23-01-2014
			CN 104684422 A	03-06-2015
			EP 2871984 A1	20-05-2015
			EP 3106047 A1	21-12-2016
			ES 2604472 T3	07-03-2017
			GB 2504076 A	22-01-2014
			HK 1204236 A1	13-11-2015
			HK 1231334 A1	22-12-2017
			JP 2015524258 A	24-08-2015
			JP 2017113001 A	29-06-2017
			KR 20150030733 A	20-03-2015
			KR 20170133523 A	05-12-2017
			UA 110897 C2	25-02-2016
			US 2015208728 A1	30-07-2015
US 2018192705 A1	12-07-2018			
WO 2014012906 A1	23-01-2014			

US 2016374399	A1	29-12-2016	US 2016374399 A1	29-12-2016
			US 2018098578 A1	12-04-2018

WO 2018125934	A1	05-07-2018	US 2018177240 A1	28-06-2018
			WO 2018125934 A1	05-07-2018
