



US00D796974S

(12) **United States Design Patent**
Dallarosa et al.

(10) **Patent No.:** **US D796,974 S**

(45) **Date of Patent:** **** Sep. 12, 2017**

(54) **LASER PROCESSING SYSTEM ENCLOSURE**

(56)

References Cited

U.S. PATENT DOCUMENTS

D603,430 S * 11/2009 Masuji D15/122

* cited by examiner

Primary Examiner — Antoine D Davis

(74) *Attorney, Agent, or Firm* — Grossman Tucker
Perreault & Pfleger, PLLC

(57)

CLAIM

The ornamental design of a laser processing system enclosure, substantially as shown and described.

DESCRIPTION

FIG. 1 is a top perspective view of a laser processing system enclosure in accordance with the present invention; FIG. 2 is a right side view thereof; FIG. 3 is a left side view thereof; FIG. 4 is a front view thereof; FIG. 5 is a rear view thereof; FIG. 6 is a top view thereof; and, FIG. 7 is a bottom view thereof. The broken lines are included for the purpose of illustrating the unclaimed portions of the article and form no part of the claim.

(71) Applicant: **IPG Photonics Corporation**, Oxford, MA (US)

(72) Inventors: **Joseph Dallarosa**, Uxbridge, MA (US);
Benjamin Amar, Worcester, MA (US);
Mark Labbe, Dayville, CT (US)

(73) Assignee: **IPG Photonics Corporation**, Oxford, MA (US)

(**) Term: **15 Years**

(21) Appl. No.: **29/544,845**

(22) Filed: **Nov. 6, 2015**

(51) **LOC (10) Cl.** **10-04**

(52) **U.S. Cl.**

USPC **D10/70; D15/122**

(58) **Field of Classification Search**

USPC D10/46, 70; D15/122

CPC G02B 7/00; G03F 7/70933; H01S 3/02;
H01S 3/225; H01S 3/005; B23K 26/12;
B23K 26/127

See application file for complete search history.

1 Claim, 7 Drawing Sheets

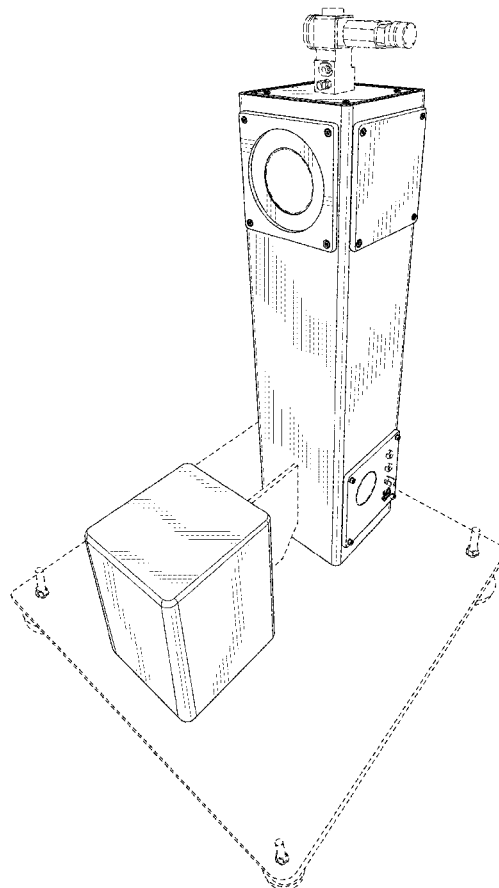

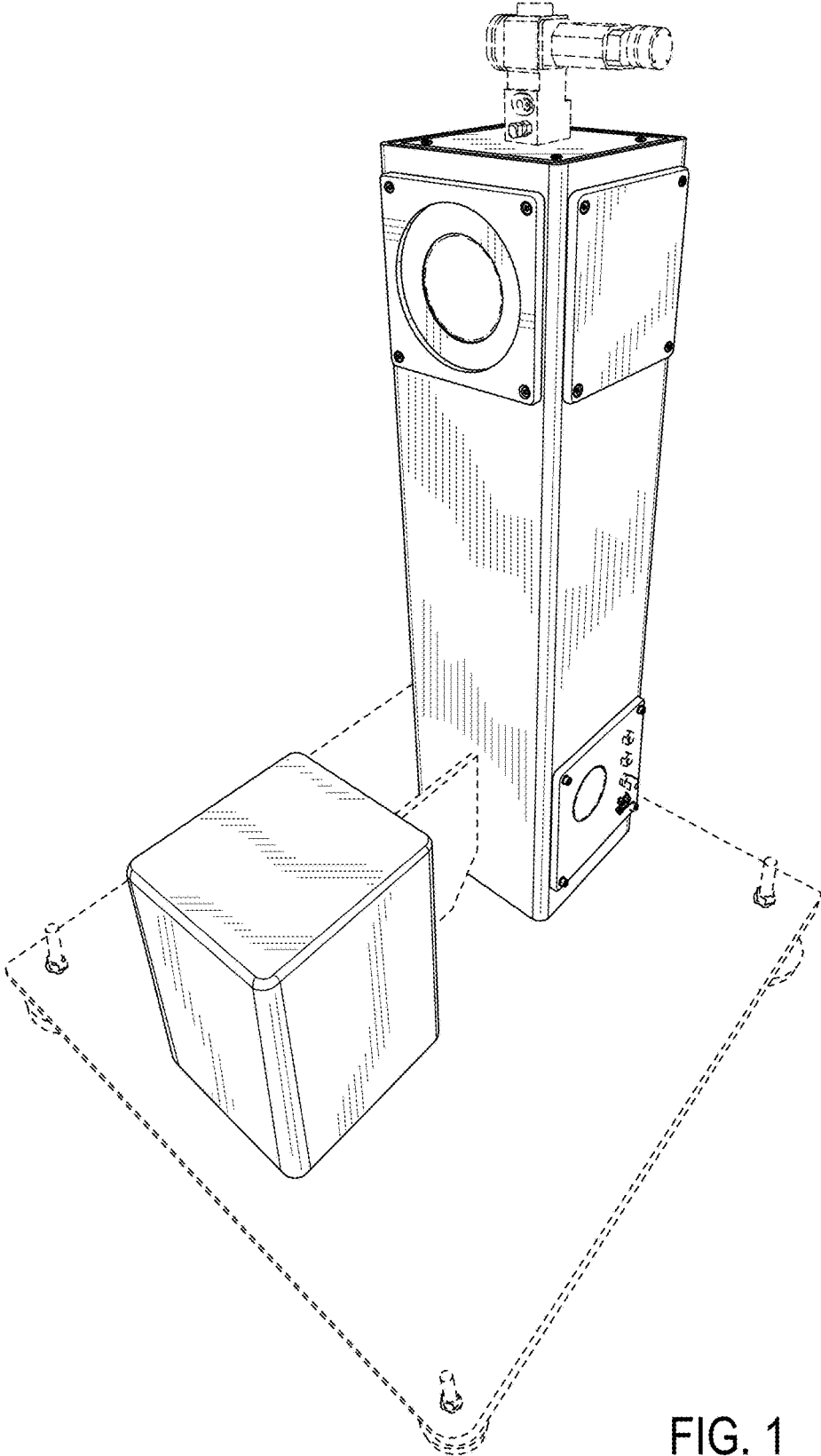

FIG. 1

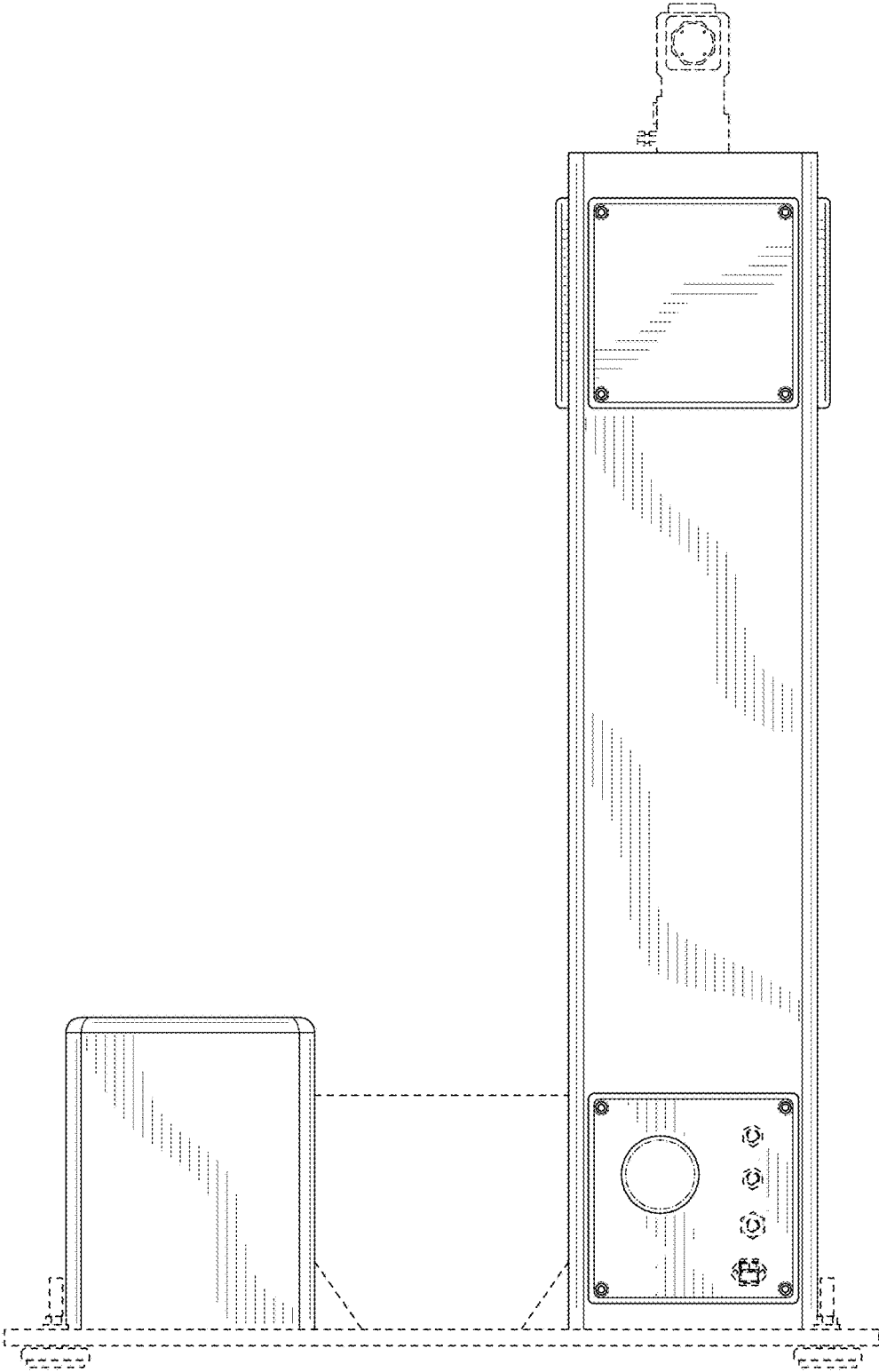

FIG. 2

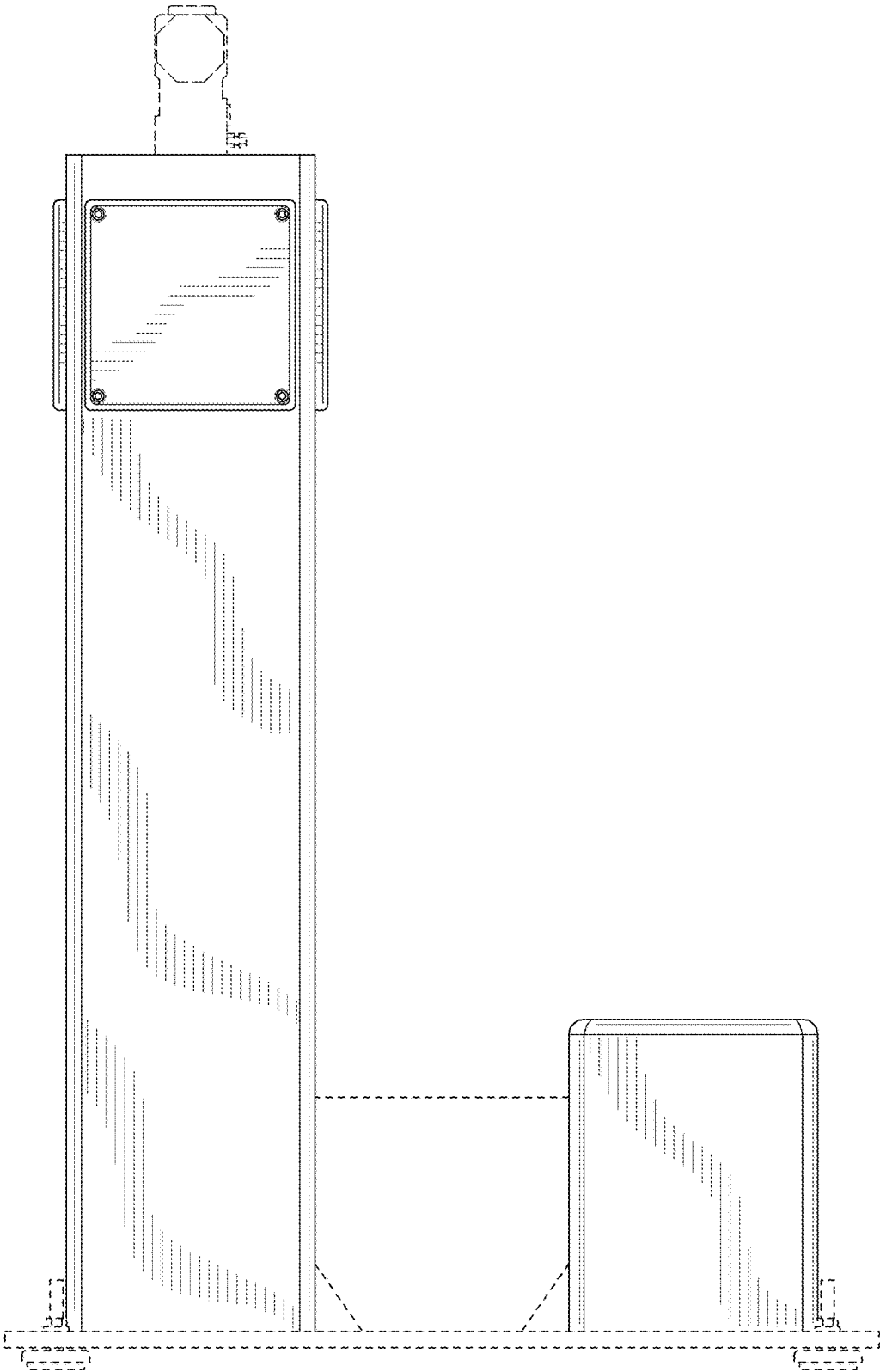

FIG. 3

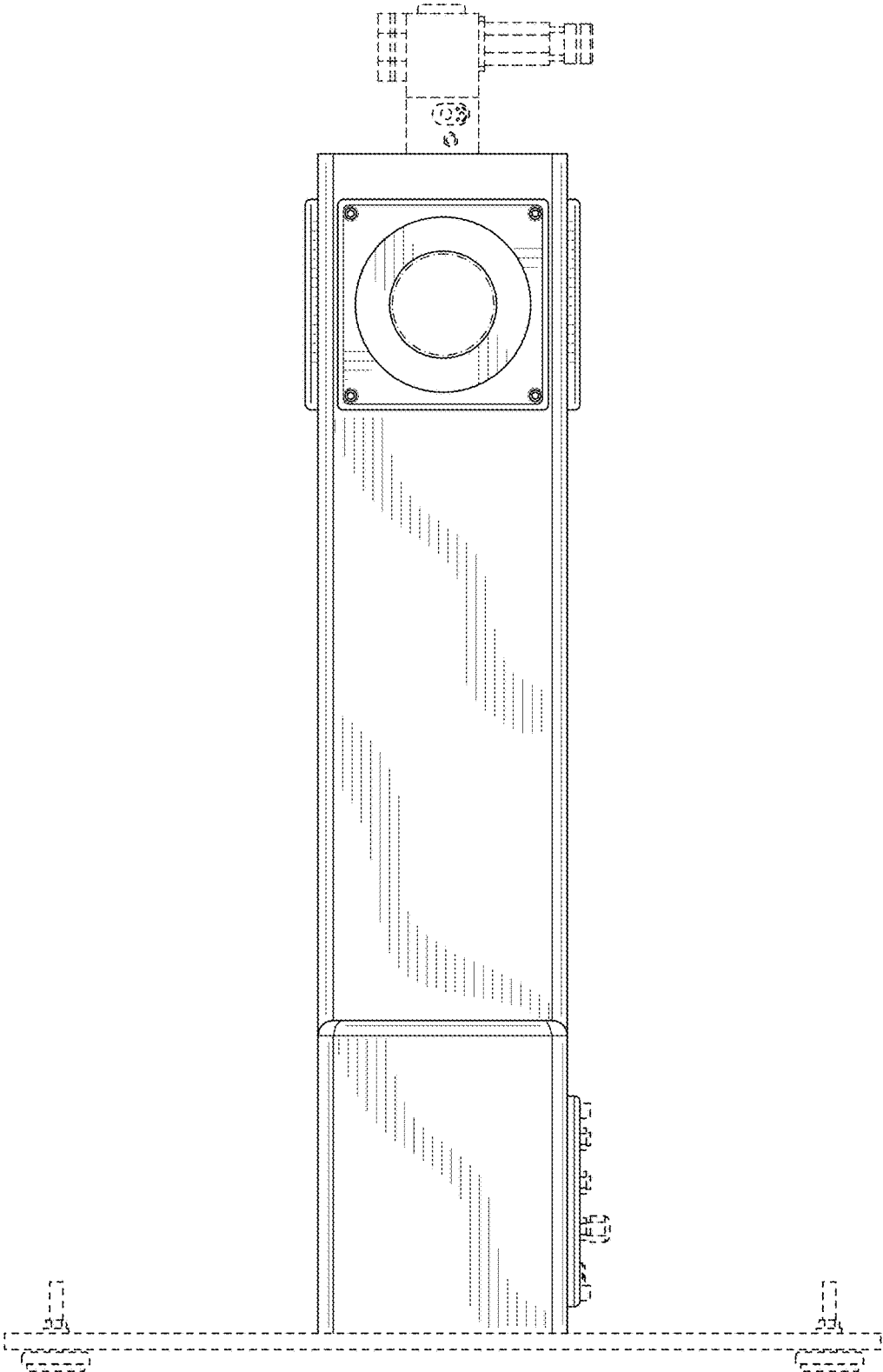

FIG. 4

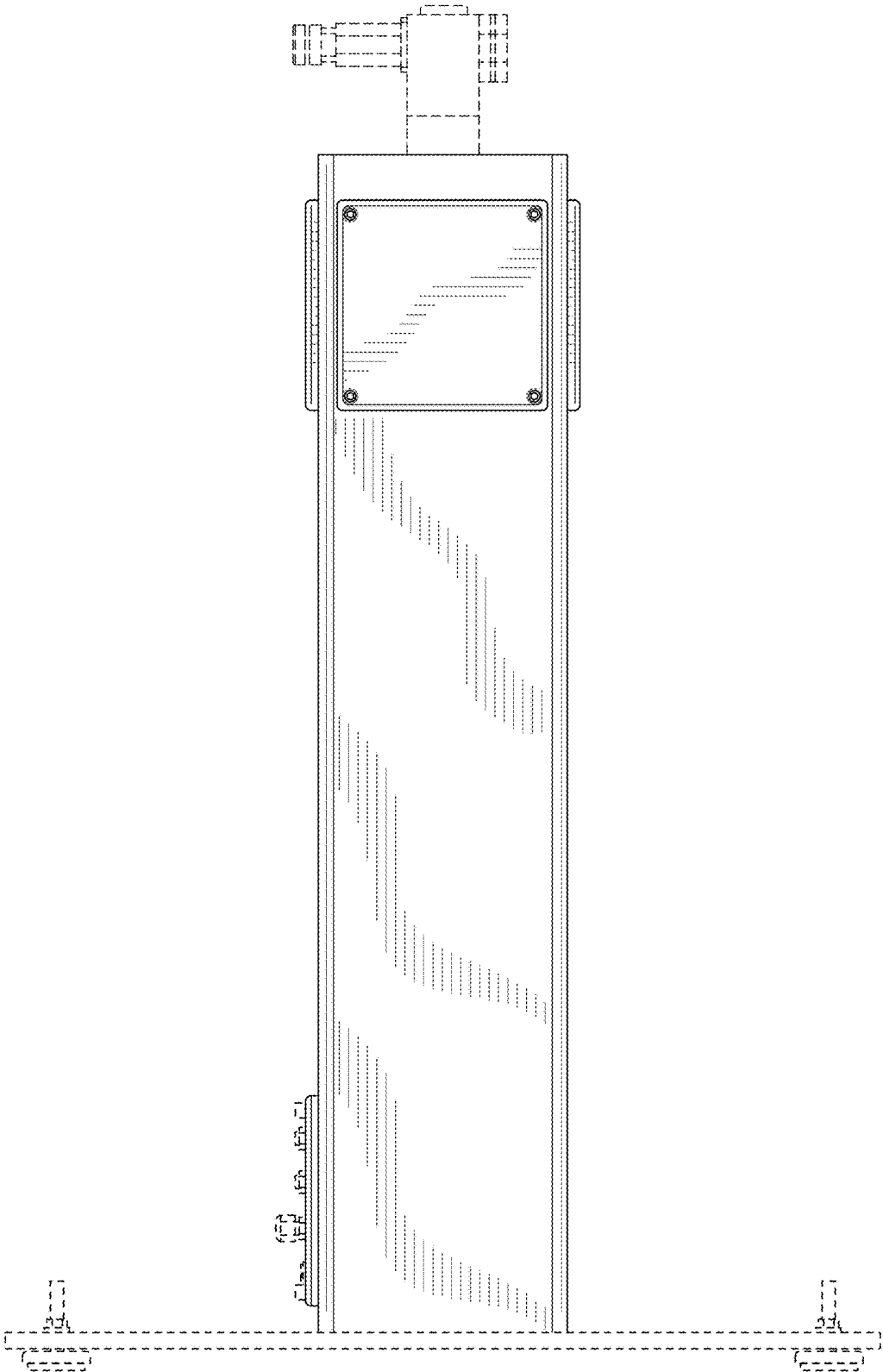

FIG. 5

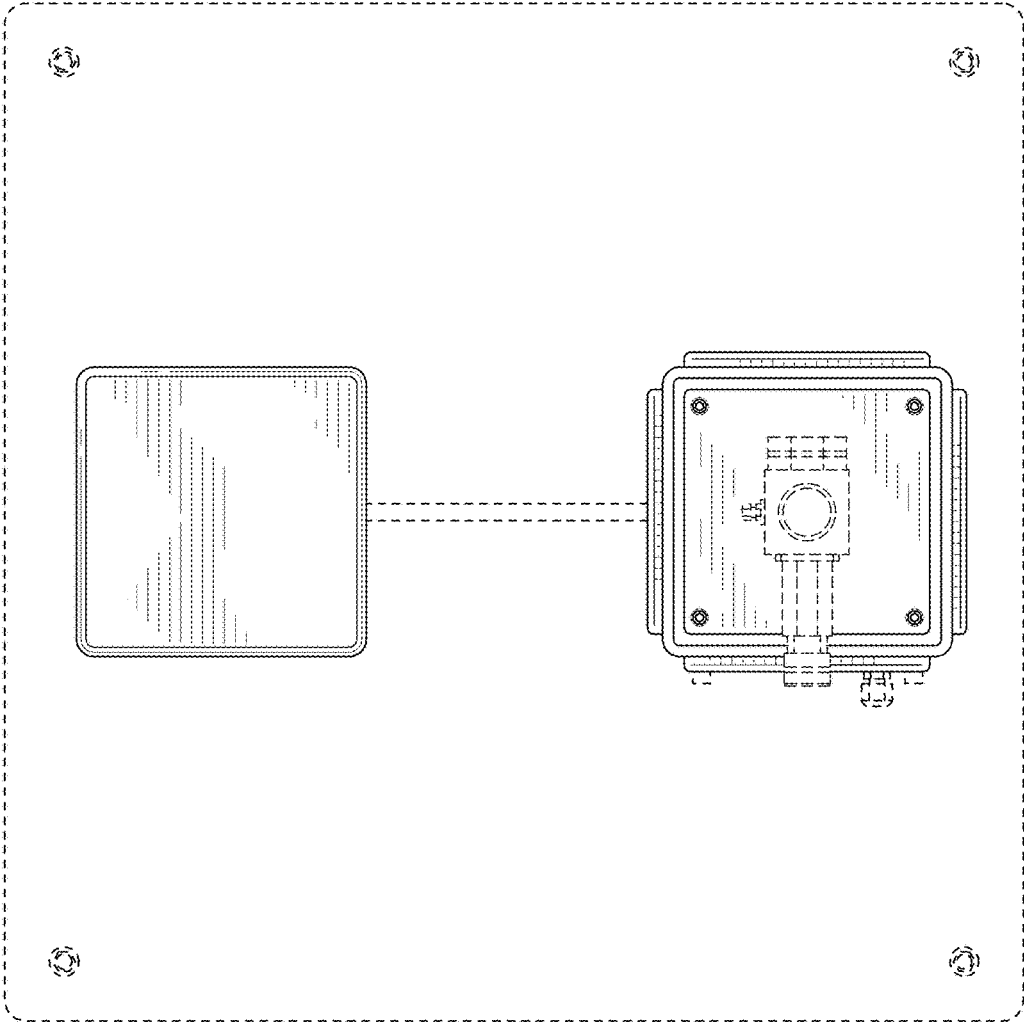

FIG. 6

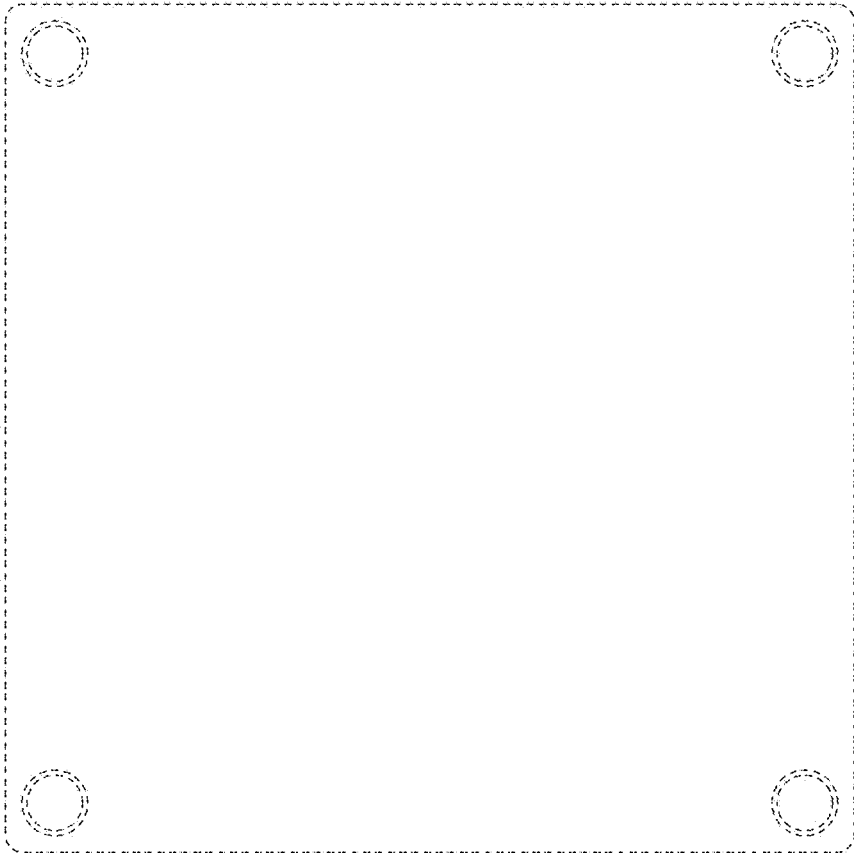

FIG. 7