



US00D520434S

(12) **United States Design Patent**  
**Fahr-Becker**

(10) **Patent No.:** **US D520,434 S**

(45) **Date of Patent:** **\*\* May 9, 2006**

(54) **FRONT FACE OF A VEHICLE WHEEL**

(75) Inventor: **Stefan Fahr-Becker**, Munich (DE)

(73) Assignee: **Bayerische Motoren Werke Aktiengesellschaft**, Munich (DE)

(\*\*) Term: **14 Years**

(21) Appl. No.: **29/213,692**

(22) Filed: **Sep. 22, 2004**

(30) **Foreign Application Priority Data**

Mar. 23, 2004 (DE) ..... 40401901

(51) **LOC (8) Cl.** ..... **12-16**

(52) **U.S. Cl.** ..... **D12/211**

(58) **Field of Classification Search** ..... D12/204-213;  
301/37.101, 64.101, 65

See application file for complete search history.

(56) **References Cited**

**U.S. PATENT DOCUMENTS**

D411,502 S \* 6/1999 Chung ..... D12/211

D430,527 S 9/2000 Noriega

D441,339 S \* 5/2001 Hussaini et al. .... D12/211

D457,119 S 5/2002 Braun et al.

D475,669 S \* 6/2003 Boyer ..... D12/209

D487,569 S \* 3/2004 Laengerer ..... D12/211

D502,679 S \* 3/2005 Boyer ..... D12/211

D504,647 S \* 5/2005 Leclercq ..... D12/209

D507,224 S \* 7/2005 Pfeiffer ..... D12/211

\* cited by examiner

*Primary Examiner*—Stacia Cadmus

(74) *Attorney, Agent, or Firm*—Crowell & Moring LLP

(57) **CLAIM**

The ornamental design for a front face of a vehicle wheel, as shown and described.

**DESCRIPTION**

FIG. 1 is a front view of a front face of a vehicle wheel according to my novel design; and,

FIG. 2 is a perspective view of the front face of a vehicle wheel according to my novel design.

The broken lines are for illustrative purposes only and form no part of the claimed design.

**1 Claim, 1 Drawing Sheet**

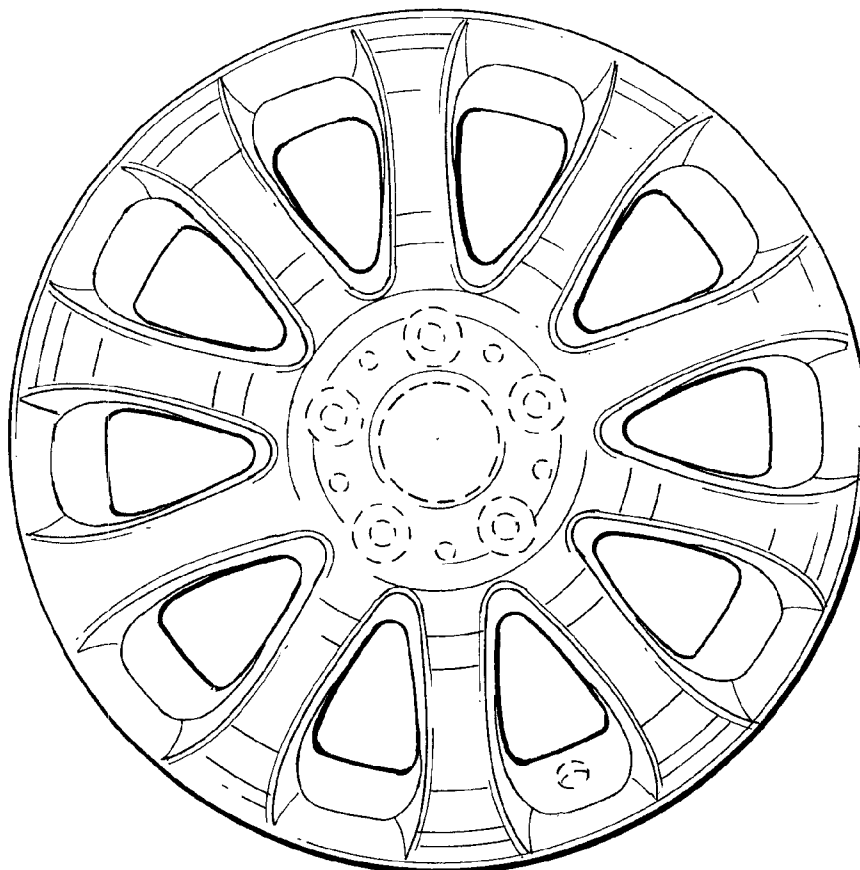

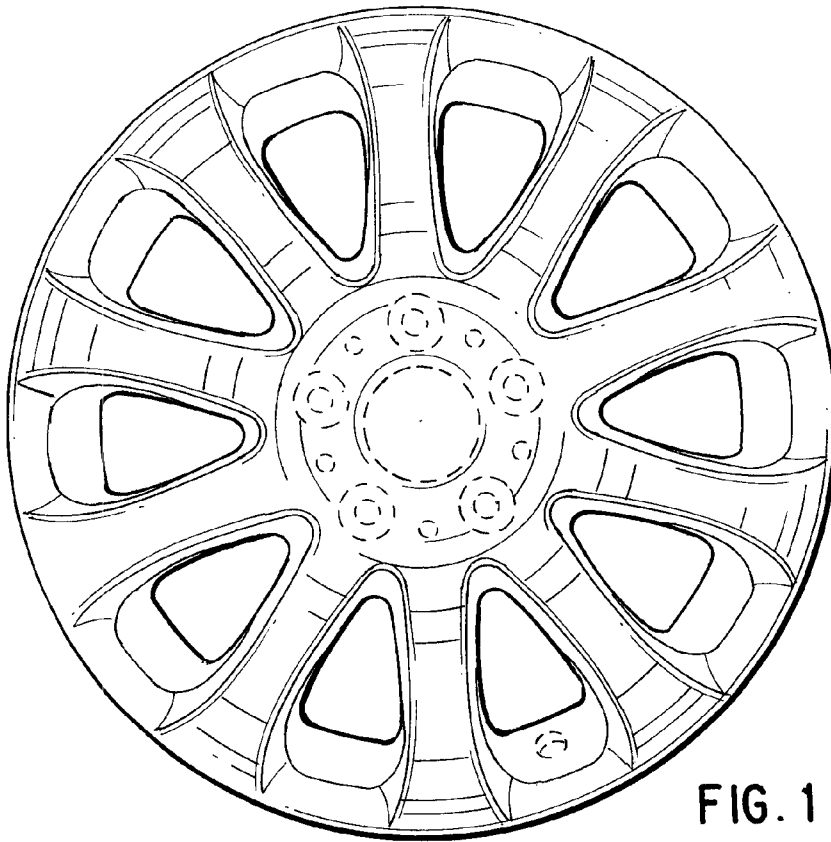

FIG. 1

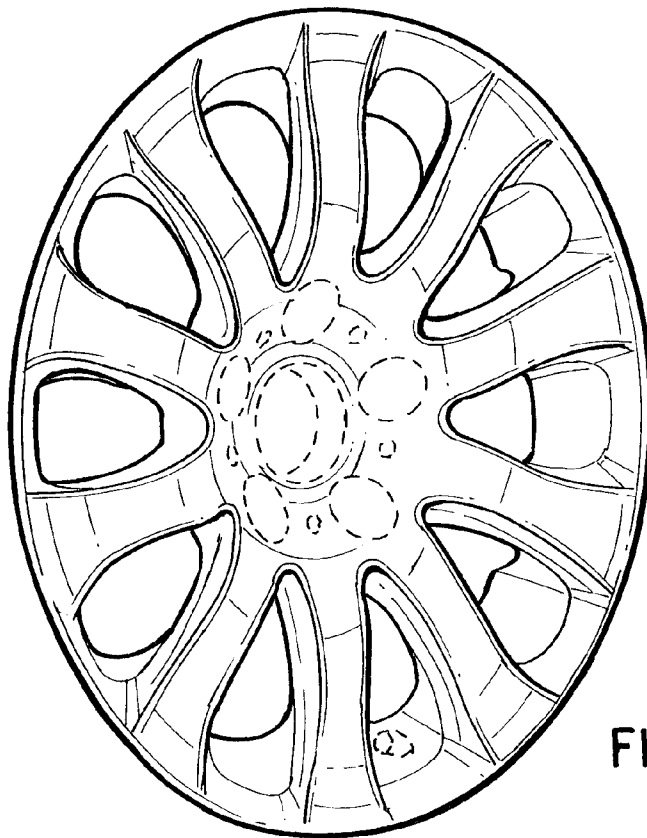

FIG. 2