

Oct. 12, 1937.

W. W. McBANE

2,095,448

ROLLING MILL BALANCE

Filed Jan. 22, 1936

Fig. 1.

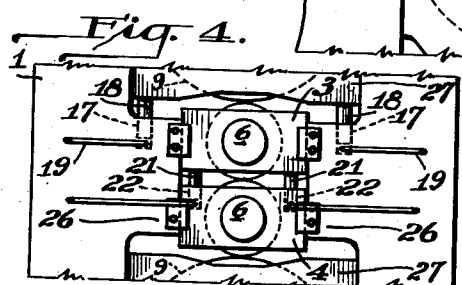
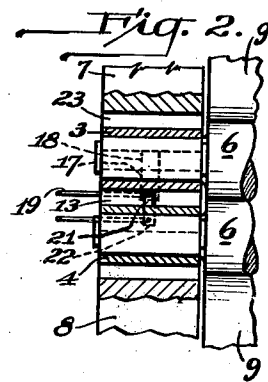
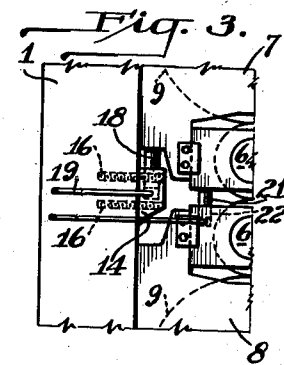
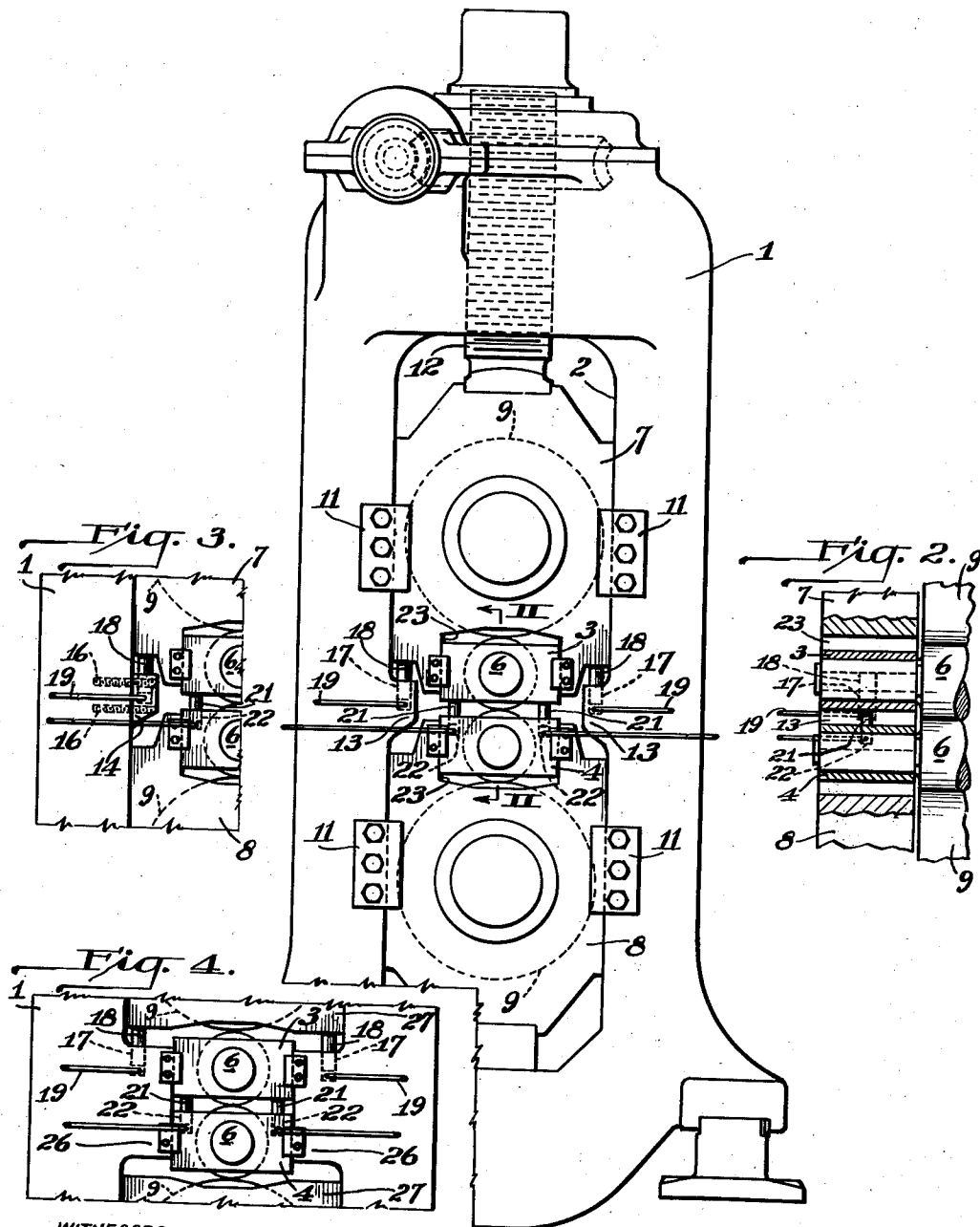

WITNESSES
A. B. Wallad.
V. A. Peckham.

INVENTOR.
Walter H. McBane
BY Brown, Spitzblow & Field
his ATTORNEYS.

UNITED STATES PATENT OFFICE

2,095,448

ROLLING MILL BALANCE

Walter W. McBane, Pittsburgh, Pa., assignor to
United Engineering & Foundry Company,
Pittsburgh, Pa., a corporation of Pennsylvania

Application January 22, 1936, Serial No. 60,224

4 Claims. (Cl. 80—56)

This invention relates to rolling mills, and more particularly to roll balances or jacks.

Among the many types of roll balances used to hold upper roll chucks in engagement with the lower ends of screw-downs are vertically adjustable jacks mounted on or in the lowermost chucks and supporting the upper chucks. In the case of hydraulic jacks, before the lower roll can be removed from the housing for replacement or re-dressing, it is first necessary to disconnect the hydraulic pipe lines from the lower chucks. Likewise, the lower chucks must be specially formed to receive the jacks.

It is among the objects of this invention to provide a rolling mill in which the upper roll chucks are supported by jacks unconnected to the remaining chucks, and in which the upper and lower roll chucks can be removed from the mill housings without moving the jacks or disconnecting them from their supply pipes. A more specific object is to provide a rolling mill in which the upper roll chucks are supported by hydraulic jacks mounted in the mill housing or in members rigidly connected to the housings.

The invention is illustrated in the accompanying drawing in which Fig. 1 is an end view of a 4-high mill; Fig. 2 is a vertical section taken on the line II—II of Fig. 1; Figs. 3 and 4 are fragmentary end views of roll housings showing two modifications of the invention.

Referring to Figs. 1 and 2 of the drawing in which one end of a 4-high mill is shown, a mill housing 1 is provided with the usual window 2 in which are mounted chucks 3 and 4 for one end of the working rolls 6, and chucks 7 and 8 for the backing rolls 9. The backing roll chucks are normally retained in the housing window in any suitable manner, such as by latches or plates 11 bolted to the housing and overlapping the faces of the chucks. This type of mounting leaves the upper chuck 7 free to slide vertically in the housing, and therefore free to be vertically adjusted by a screw-down 12 of any suitable form extending downwardly through the top of the housing and into the window where it engages the top of the upper chuck.

To balance upper chucks 7, that is, to hold them firmly against the bottoms of the screw-downs, jacks are mounted between the upper and lower backing roll chucks where they support the bottoms of the upper chucks. It is a feature of this invention that these jacks, instead of being mounted in the lower backing roll chucks, are mounted in housing elements of any suitable form, such as blocks 13, projecting into the win-

dow from the roll housings between upper and lower chucks 7 and 8, whereby the upper backing roll chucks are supported entirely by the housing. Each of the blocks 13, which may be integral with the housing (Fig. 1) or connected thereto as separate elements 14 by bolts 16 or the like (Fig. 3), is provided in its upper portion with a vertical bore forming a cylinder 17. Slidably mounted in this cylinder is a plunger 18 the upper end of which engages the bottom of the upper backing roll chuck.

These plungers may be biased against the upper chucks by any suitable means acting between the bottoms of the cylinders and plungers. However, it is preferred to hold the plungers against the upper chucks, and to adjust them vertically to support the chucks against the vertically adjustable screw-downs, by fluid pressure such as hydraulic pressure. Accordingly, a conduit 19 is connected to the lower end of each cylinder, the opposite end of the conduit being connected to a suitable source of fluid pressure in the usual manner.

Due to the fact that the hydraulic jacks are mounted in projections of the mill housing, any or all of the chucks can be removed from the housing without disconnecting conduits 19. This shortens the time required for changing the rolls. Likewise, as upper chucks 7 are supported from the housing the remaining chucks and rolls can be removed without disturbing them. This construction also allows the use of ordinary backing roll chucks because the jacks are not mounted in them, and the upper and lower chucks can be identical and therefore interchangeable.

To hold the upper working roll 6 firmly against the upper backing roll so that there will be no slippage between them and no chattering when material enters the roll pass, the two working rolls are constantly urged apart by plungers 21 slidably mounted in hydraulic cylinders 22 or the like in the lower working roll chucks 4, the plungers bearing against the bottoms of upper working roll chucks 3.

The working roll chucks can be nested in the backing roll chucks, as shown in Fig. 1, where the forms are slidably mounted in recesses 23 in the backing roll chucks. Or, if desired, the mill housings can be formed as shown in Fig. 4, with enlarged integral block-like projections 26 extending inwardly toward each other far enough to engage the sides of the working roll chucks for which they form lateral supports and guides between which the chucks are vertically adjustable by plungers 21. This construction makes the

working roll chucks entirely independent of the backing roll chucks 21 so that the latter do not have to be recessed to receive and guide the former. Plungers 18 of the hydraulic jacks for the upper backing roll chucks are disposed in cylinders 17 in projections 26.

According to the provisions of the patent statutes, I have explained the principle and construction of my invention, and have illustrated and described what I now consider to be its best embodiment. However, I desire to have it understood that, within the scope of the appended claims, the invention may be practiced otherwise than as specifically illustrated and described.

15 I claim:

1. A rolling mill comprising a roll housing provided with windows, upper and lower backing roll chucks mounted in said windows, said housing having portions projecting into said windows 20 between said upper and lower chucks, jacks mounted in said portions and supporting said upper chucks, upper and lower working roll chucks mounted between and supported by said portions of the housing in each window, and means engaging said upper and lower working roll chucks for biasing them away from each other.

2. A rolling mill comprising a roll housing provided with windows, upper and lower backing roll chucks mounted in said windows, said housing being provided in each window with oppositely disposed integral block-like portions projecting inwardly between said upper and lower chucks and having substantially parallel inner faces, each of said block-like portions being provided with a cylinder, a plunger slidably disposed therein with its upper end engaging one of the

upper chucks, fluid pressure means for raising said plungers in the cylinders to support said upper chucks, upper and lower working roll chucks mounted between and in engagement with said parallel faces of said block-like portions of the housing, and means engaging said upper and lower working roll chucks for biasing them away from each other.

3. A rolling mill comprising a roll housing provided with windows, upper and lower backing roll chucks mounted in said windows, said housing having portions projecting into said windows between said upper and lower chucks, jacks mounted in said portions and supporting said upper chucks, upper and lower working roll chucks mounted between and supported by said portions of the housing in each window, and means engaging said upper working roll chuck for biasing it away from the lower roll chuck.

4. A rolling mill comprising a roll housing provided with windows, upper and lower backing roll chucks mounted in said windows, said housing being provided in each window with oppositely disposed integral block-like portions projecting inwardly between said upper and lower chucks and having substantially parallel inner faces, each of said block-like portions being provided with a cylinder, a plunger slidably disposed therein with its upper end engaging one of the upper chucks, fluid pressure means for raising said plungers in the cylinders to support said upper chucks, upper and lower working roll chucks mounted between and in engagement with said parallel faces of said block-like portions of the housing, and means engaging said upper working roll chuck for biasing it away from the lower roll chuck.

WALTER W. MCBANE.