

March 17, 1959

A. L. SAEKS

2,878,061

MOTH PREVENTIVE AND DEODORANT DISPENSERS

Filed Oct. 22, 1957

2 Sheets-Sheet 1

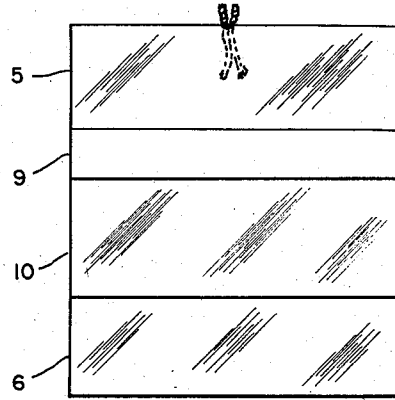
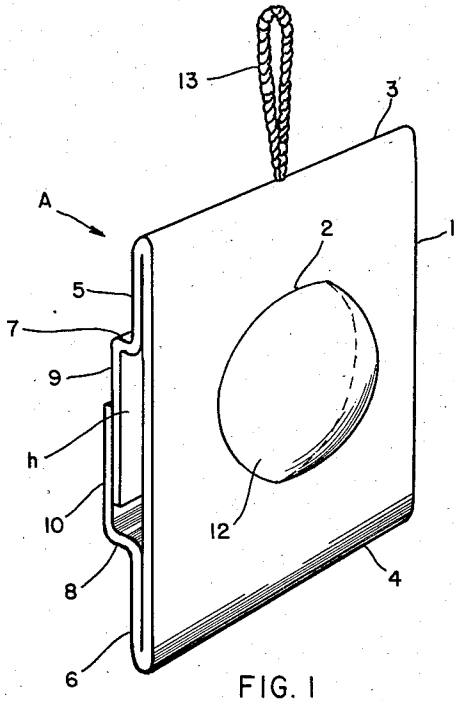

FIG. 2

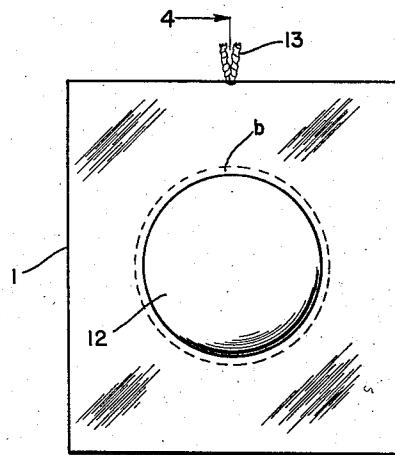

FIG. 3

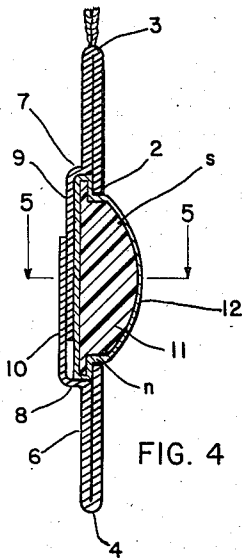

FIG. 4

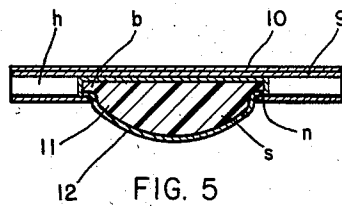

FIG. 5

INVENTOR.

ALVIN L. SAEKS

BY *Alfred Whitehead*

ATT'Y.

March 17, 1959

A. L. SAEKS

2,878,061

MOTH PREVENTIVE AND DEODORANT DISPENSERS

Filed Oct. 22, 1957

2 Sheets-Sheet 2

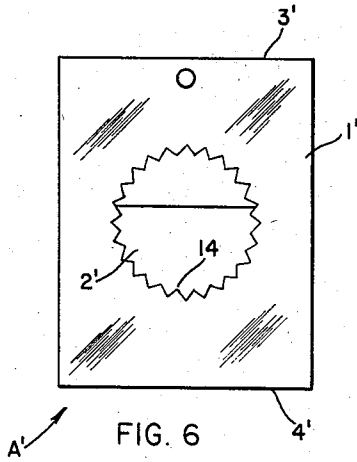

FIG. 6

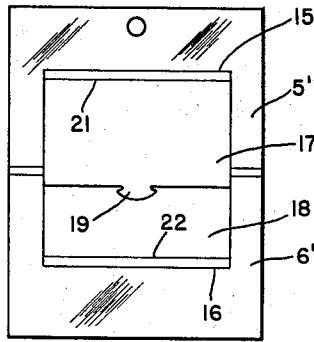

FIG. 7

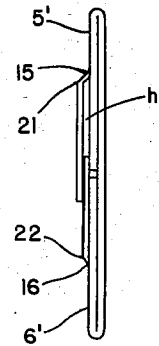

FIG. 8

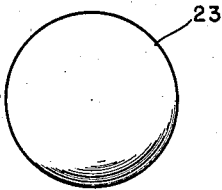

FIG. 9

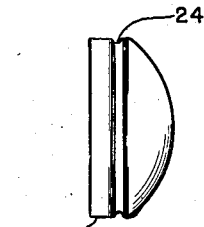

FIG. 10

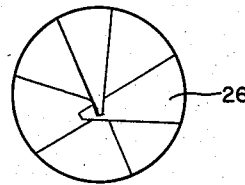

FIG. 11

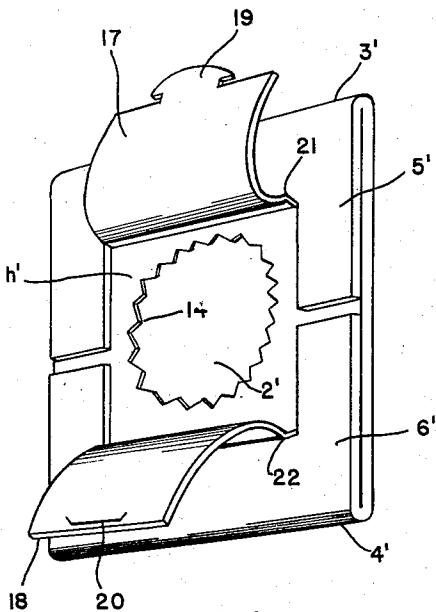

FIG. 12

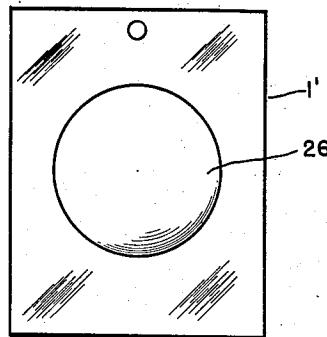

FIG. 13

INVENTOR.

ALVIN L. SAEKS

BY

afred wetchcraft

ATT'Y

1

2,878,061

MOTH PREVENTIVE AND DEODORANT DISPENSERS

Alvin L. Saeks, Clayton, Mo., assignor to The Puro Co., Inc., St. Louis, Mo., a corporation of Missouri

Application October 22, 1957, Serial No. 691,573

11 Claims. (Cl. 299—24)

This invention relates in general to certain new and useful improvements in moth preventive and deodorant dispensers and, more particularly, to a decorative card-type dispenser which may be conveniently hung in closets, bathrooms, and the like.

Blocks or cakes of compressed paradichlorobenzene or naphthalene have been widely used as deodorants and moth preventives both for household as well as commercial purposes. Such blocks or cakes may be laid upon closet shelves, placed in foraminous receptacles, such as perforated metal containers, and hung in closets or bathrooms. The naphthalene or paradichlorobenzene, upon being exposed to atmosphere, sublimates and gives off a desirable vapor which has deodorizing and mothcidal properties. Consequently, it is necessary that the cakes or blocks be enclosed in an airtight package prior to use, so that these products will have a suitable shelf-life until purchased and actually put into use. Obviously, such packaging adds materially to the cost of the product and imposes considerable inconvenience upon the housewife who must unwrap the cake of chemical reagent in order to place it in a suitable receptacle or otherwise put it to use. In so doing, the fingers become soiled and, in general, the procedure is both inconvenient and time-consuming.

It is, therefore, the primary object of the present invention to provide a deodorant and mothcidal card which can be very conveniently hung in a closet or otherwise disposed at a place of use.

It is another object of the present invention to provide a simple, but nevertheless highly decorative, mothcidal and deodorant device which can be economically assembled and packaged for distribution and sale.

It is a further object of the present invention to provide a deodorant and mothcidal device of the type stated which is highly attractive at point of sale and yet has the deodorant or mothcidal chemical protected in such a manner that the device will have adequate shelf-life prior to purchase and actual use.

With the above and other objects in view, my invention resides in the novel features of form, construction, arrangement, and combination of parts presently described and pointed out in the claims.

In the accompanying drawings (two sheets),

Fig. 1 is a perspective view of a mothcidal and deodorant dispenser constructed in accordance with and embodying the present invention;

Fig. 2 is a rear elevational view of the mothcidal and deodorant dispenser;

Fig. 3 is a front elevational view of the mothcidal and deodorant dispenser;

Fig. 4 is a vertical sectional view taken along line 4—4 of Fig. 3;

Fig. 5 is a transverse sectional view taken along line 5—5 of Fig. 4;

Fig. 6 is a front elevational view of a modified form of holder-card forming a part of the present invention;

2

Fig. 7 is a rear elevational view of the holder-card shown in Fig. 6;

Fig. 8 is a side elevational view of the holder-card shown in Fig. 6;

5 Fig. 9 is a front elevational view of the mothcidal and deodorant block used with the holder-card shown in Fig. 6;

Fig. 10 is a side elevational view of the mothcidal and deodorant block shown in Fig. 9;

10 Fig. 11 is a rear elevational view of the mothcidal and deodorant block shown in Fig. 9;

Fig. 12 is a rear perspective view on an enlarged scale of the holder-card of Fig. 6, with the rear flaps in outwardly bent position preparatory to insertion of the mothcidal and deodorant block; and

15 Fig. 13 is a front elevational view of the modified form of mothcidal and deodorant dispenser employing the holder-card of Fig. 6.

Referring now in more detail and by reference characters to the drawings, which illustrate practical embodiments of the present invention, A designates a mothcidal and deodorant dispenser comprising a card 1 preferably, though not necessarily, of oblong-rectangular shape and centrally provided with a large aperture 2 which is preferably of circular contour. Along its top and bottom margins 3, 4, the card 1 is bent back upon itself in the provision of back panels 5, 6, which are folded into facewise contact with the rearwardly presented face of the card 1 and preferably secured thereto by a conventional adhesive. As will be seen by reference to the drawings, the rear panels 5, 6, extend only partially downwardly across the rear face of the card 1 and at their lower and upper margins, respectively, are bent backwardly in the formation of flanges 7, 8, which are, in turn, respectively bent downwardly and upwardly again to provide rear flaps 9, 10, adapted to overlap, as shown in Figs. 1 and 4, to form a channel-shaped pocket *h* in back of the aperture 2. It should also be noted in this connection that the vertical distance between the flanges 7, 8, is substantially greater than the diameter of the aperture 2, all as best seen in Fig. 4 and for purposes presently more fully appearing.

Provided for snug-fitting disposition within the aperture 2 and projecting forwardly therefrom is a mothcidal and deodorant pellet or block 11 formed preferably of perfumed and compressed paradichlorobenzene, naphthalene, or the like. It is also possible to use inert matrix materials saturated with a volatile liquid having mothcidal, fungicidal or deodorant properties. This pellet or block 11 integrally includes a relatively large base portion *b* having a peripheral size substantially greater than the size of the aperture 2 and a thickness such that it will fit snugly within the pocket *h*, so that the pellet or block 11 will be held securely between the rear face of the card 1 and the interiorly presented faces of the flaps 9, 10. Extending forwardly from the base *b* is a cylindrical neck portion *n* of such diametral size as to fit snugly within and through the aperture 2 and at its forward end the neck portion *n* merges into a forwardly projecting hemispherical section *s*. The pellet or block 11 is wrapped or otherwise tightly enclosed and sealed within a non-pervious preferably transparent sheet or membrane 12 formed of cellophane or some similar material which will prevent the block 11 from subliming. Thus wrapped, the pellet or block is pushed into place within the aperture 2 and the flaps 9, 10, glued or otherwise suitably secured in place.

Glued or otherwise suitably secured between the card 1 and back panel 5 and extending upwardly through the top margin 2 is a looped cord 13 by which the dispenser A may be suspended from a suitable hook or nail (not shown).

3

In use, a small tear or slit can be formed in the membrane 12 preferably in the area which is tautly stretched over the exposed face of the hemispherical section, thereby exposing the mothcidal and deodorant block 11 to the atmosphere of the enclosed space. The dispenser A may then be placed on a shelf, or, if desired, hung up in suspended position by means of the cord 13. By making the tear or slit, either large or small, it is possible to control the rate of sublimation of the block 11. In due time, the chemical constituents of the block 11 will have completely sublimed and the card 1 can be replaced with a fresh one.

It is also possible to provide a modified form of mothcidal and deodorant dispenser A', as shown in Figs. 6 to 13, inclusive, which comprises a card 1' having a central aperture 2' having a notched margin formed by a uniformly spaced series of scallops 14. Along its upper and lower margins 3', 4', the card 1' is bent backwardly upon itself, in the provision of back panels 5', 6', which are glued down upon the rearwardly presented face of the card 1'. Joined to the panels 5', 6', along score lines 15, 16, are rear flaps 17, 18, which are symmetrical with and narrower than the back panels 5', 6'. On its free longitudinal margin, the rear flap 17 is provided with a tongue 19 which is adapted to engage a slit 20 formed in the rear flap 18. Outwardly with respect to the score lines 15, 16, and in spaced parallel relation thereto, the flaps 17, 18, are provided with score lines 21, 22, so that the rear flaps 17, 18, can be folded down into overlapping position and locked together to form a pocket h' in back of the aperture 2'.

Provided for snug-fitting disposition within the aperture 2' is a mothcidal and deodorant pellet or block 23 formed preferably of the same composition as the block 11 previously described. The pellet or block 23 is preferably of circular cross-sectional shape and includes a groove-like neck portion 24 which fits snugly within and through the aperture 2', so that the scallops 14 are disposed within the groove 24. The pellet or block 23 is furthermore provided with an annular flange 25, preferably of larger diameter than the aperture 2', which rests against the rearwardly presented face of the card 1'. It should, of course, be understood that the pellet or block 23 may be of various different shapes other than the particular shape shown and described herein, provided only that some form of peripherally enlarged flange be present for snug-fitting retentive disposition within the pocket h'. The pellet or block 23 is tightly wrapped in a removable protective sheet or membrane 26 of cellophane or other similar airtight material in the same manner and for the same purpose as previously described in connection with the block 11.

In use, the flaps 17, 18, are folded back to the position shown in Fig. 12 and the wrapped block 23 placed within the aperture 2', allowing the scallops 14 to snap into the groove-like neck 24. The flaps 17, 18, are then closed and the tongue 19 is positioned within the slit 20 so as to enclose the rear face of the block 23. The flaps 17, 18, will bend along the score lines 21, 22, so as to engage the rear face of the wrapped pellet or block 23.

When it is desired to use the dispenser A', it is merely necessary to tear or remove the membrane 26 from the outwardly presented face of the block 23 prior to placing or hanging the dispenser A' in a closet or other similar enclosure.

It should be understood that changes and modifications in the form, construction, arrangement, and combination of the several parts of the moth preventive and deodorant dispenser may be made and substituted for those herein shown and described without departing from the nature and principle of my invention.

Having thus described my invention, what I claim and desire to secure by Letters Patent is:

1. A mothcidal and deodorant dispenser comprising

4

a card having an aperture therein, said card also being bent backwardly upon itself along two opposed margins to form a pair of panels, said panels extending partially downwardly along the rear face of the card and being facewise secured to said rearwardly presented face, a block capable of giving off vapor, said block being disposed in and projecting through said aperture, and a plurality of flaps integrally formed on said panels, said flaps being adapted to overlap and secure said block in said aperture.

2. A mothcidal and deodorant dispenser comprising a card having an aperture therein, said card also being bent backwardly upon itself along two opposed margins to form a pair of panels, said panels extending partially downwardly along the rear face of the card and being facewise secured to said rearwardly presented face, a block capable of giving off vapors, said block being positioned in said aperture and having a portion thereof projecting forwardly from said card and a portion projecting rearwardly from said card, and flap means on said panels for holding said rearwardly projecting portion against said card.

3. A mothcidal and deodorant dispenser comprising a card having an aperture therein, said card also being bent backwardly upon itself along two opposed margins to form a pair of panels, said panels extending partially downwardly along the rear face of the card and being facewise secured to said rearwardly presented face, a mothcidal and deodorant block having a neck portion positioned in said aperture, said block having a major portion thereof projecting forwardly from said card and a flange portion projecting rearwardly of said card, said flange portion being disposed against said card and having a diameter greater than said aperture, and a pair of flaps formed on said panels for holding said flange against said card.

4. A mothcidal and deodorant dispenser comprising a card having an aperture therein, said card also being bent backwardly upon itself along two opposed margins to form a pair of panels, said panels extending partially downwardly along the rear face of the card and being facewise secured to said rearwardly presented face, a block formed of mothcidal and deodorant chemicals, said block being positioned in said aperture, said block having a major portion thereof projecting forwardly from said card and a flange portion projecting rearwardly of said card, said flange portion being disposed against said card and having a diameter greater than said aperture, and a plurality of flaps formed on said panels for holding said flange against said card.

5. A mothcidal and deodorant dispenser comprising a card having an aperture therein, said card also being bent backwardly upon itself along two opposed margins to form a pair of panels, said panels extending partially downwardly along the rear face of the card and being facewise secured to said rearwardly presented face, a vaporizable block having a neck portion positioned in said aperture, said block having a major portion thereof projecting forwardly from said card and a flange portion projecting rearwardly of said card, said flange portion being disposed against said card and having a diameter greater than said aperture, and a plurality of flaps formed on said panels for holding said flange against said card, said flaps being secured together in overlapping relation so that they lie in rearwardly spaced relation to said panels.

6. A mothcidal and deodorant dispenser comprising a card having an aperture therein, said card also being bent backwardly upon itself along two opposed margins to form a pair of panels, said panels being facewise secured to the rearwardly presented face of the card, a vaporizable block having a neck portion positioned in said aperture, said block having a major portion thereof projecting forwardly from said card and a flange portion pro-

jecting rearwardly of said card, said flange portion being disposed against said card and having a diameter greater than said aperture, a plurality of flaps formed on said panels for holding said flange against said card, and means for securing said flaps together in overlapping relation, in which position the flaps are in overlying rearwardly spaced relation to said aperture.

7. A mothicial and deodorant dispenser comprising a card having an aperture therein, said card also being bent backwardly upon itself along two opposed margins to form a pair of panels, said panels being facewise secured to the rearwardly presented face of the card, a vaporizable block having a neck portion positioned in said aperture, said block having a major portion thereof projecting forwardly from said card and a flange portion projecting rearwardly of said card, said flange portion being disposed against said card and having a diameter greater than said aperture, and a plurality of flaps formed on said panels for holding said flange against said card, said flaps being adhesively secured in overlapping relation, in which position the flaps are in overlying rearwardly spaced relation to said aperture.

8. A mothicial and deodorant dispenser comprising a card having an aperture therein, the margins of which are provided with corrugations, said card also being bent backwardly upon itself along two opposed margins to form a pair of panels, said panels being facewise secured to the rearwardly presented face of the card, a vaporizable block having a neck portion positioned in said aperture, said block having a major portion thereof projecting forwardly from said card and a flange portion projecting rearwardly of said card, said flange portion being disposed against said card and having a diameter greater than said aperture, a pair of opposed flaps hingedly secured to said panels along lines intermediate the two opposed margins, and means for holding said flaps together in overlapping relation, said flaps being adapted to hold said flange against said card.

9. A mothicial and deodorant dispenser comprising a card having an aperture therein, said card also being bent backwardly upon itself along two opposed margins to form a pair of panels, said panels being facewise secured to the rearwardly presented face of the card, a vaporizable block having a neck portion positioned in said aperture, said block having a major portion thereof projecting forwardly from said card and a flange portion projecting rearwardly of said card, said flange portion being disposed against the rearwardly presented face of said

card and having a diameter greater than said aperture, a pair of opposed flaps hingedly secured to said panels along lines intermediate the two opposed margins, said flaps being narrower than said panels, and means for releasably securing said flaps together in overlapping relation, said flaps being adapted to hold said flange against said rearwardly presented face of said card.

10. A mothicial and deodorant dispenser comprising a card having an aperture therein, said card also being bent backwardly upon itself along two opposed margins to form a pair of panels, said panels being facewise secured to the rearwardly presented face of the card, a pair of opposed flaps secured to said panels along hinge-forming lines intermediate said two opposed margins, means for releasably securing said flaps together in overlapping relation, said flaps also being foldable along lines outwardly of said hinge-forming lines so that when the flaps are secured together they will form a pocket contiguous with said aperture, and a vaporizable block having a neck portion positioned in said aperture and a flange portion disposed within said pocket, said vaporizable block having a major portion thereof projecting forwardly from said card.

11. A mothicial and deodorant dispenser comprising a card having an aperture therein, said card also being bent backwardly upon itself along two opposed margins to form a pair of panels, said panels being facewise secured to the rearwardly presented face of the card, a pair of opposed flaps secured to said panels along hinge-forming lines intermediate said two opposed margins and being narrower than said panels, means for releasably securing said flaps together in overlapping relation, said flaps also being foldable along lines outwardly of said hinge-forming lines so that when the flaps are secured together they will form a pocket contiguous with said aperture, and a vaporizable block having a neck portion positioned in said aperture and a flange portion disposed within said pocket, said vaporizable block having a major portion thereof projecting forwardly from said card.

References Cited in the file of this patent

UNITED STATES PATENTS

1,115,860	Owen	Nov. 3, 1914
2,228,918	Wesselmann	Jan. 14, 1941
2,604,204	Rockey et al.	July 22, 1952
2,802,569	Massey	Aug. 13, 1957
2,806,312	Grumbacher	Sept. 17, 1957
2,809,863	Curran	Oct. 15, 1957