

[54] **SHOCK-PROOF PACKING CONTAINER**
 [76] Inventor: **Oscar Bluemel**, 4530 N. Albany Ave., Chicago, Ill. 60625
 [22] Filed: **Feb. 22, 1971**
 [21] Appl. No.: **117,468**

427,638 6/1967 Switzerland..... 206/46 FR

Primary Examiner—Leonard Summer
Attorney—Ronald L. Engel, Daniel W. Vittum, Jr., Gomer W. Walters and John A. Waters

[52] U.S. Cl. 206/46 FR, 229/14 C
 [51] Int. Cl. **B65d 85/30**
 [58] Field of Search..... 206/46 FR; 229/14 C, 229/15; 217/52, 28

[57] **ABSTRACT**

A shock-proof packing container for shipping fragile articles comprises a rectangular outer carton, a polygonal inner support member that is adapted to fit snugly within the outer carton and bear against all four side walls of the outer carton, and a flexible sling attached to opposing walls of the inner support member and extending therebetween. Fragile articles are wrapped in this sling and are thereby suspended in the interior of the packing container. Locking flaps are attached to the inner support member so that the position of the inner support member with respect to the outer carton remains fixed.

[56] **References Cited**
UNITED STATES PATENTS

2,242,741	5/1941	Betts et al.	229/14 C X
2,749,013	6/1956	Wilkinson	229/14 C
1,633,229	6/1927	Rosenthal	229/14 C
1,996,965	4/1935	Keppler	206/45.19
2,837,208	6/1958	Lingenfelter.....	206/46 FR
3,397,831	8/1968	Adams.....	229/15 X
3,437,198	4/1969	Van Saun et al.	206/46 FR X

FOREIGN PATENTS OR APPLICATIONS

237,322	7/1925	Great Britain	206/46 FR
---------	--------	---------------------	-----------

10 Claims, 5 Drawing Figures

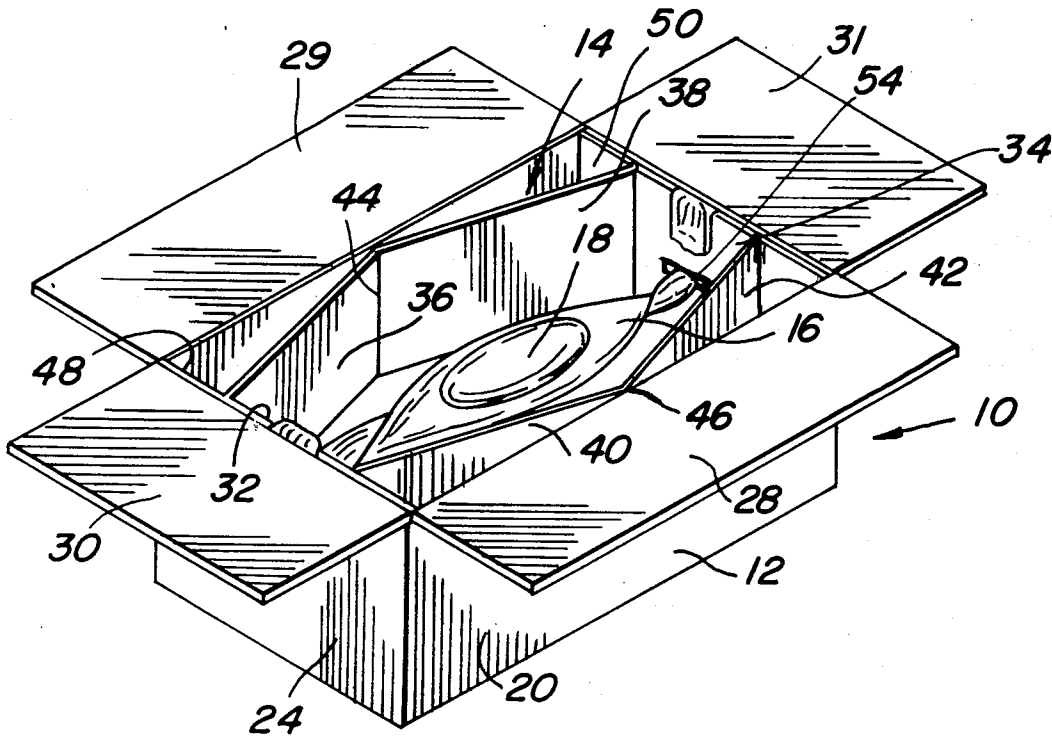

Patented Aug. 14, 1973

3,752,301

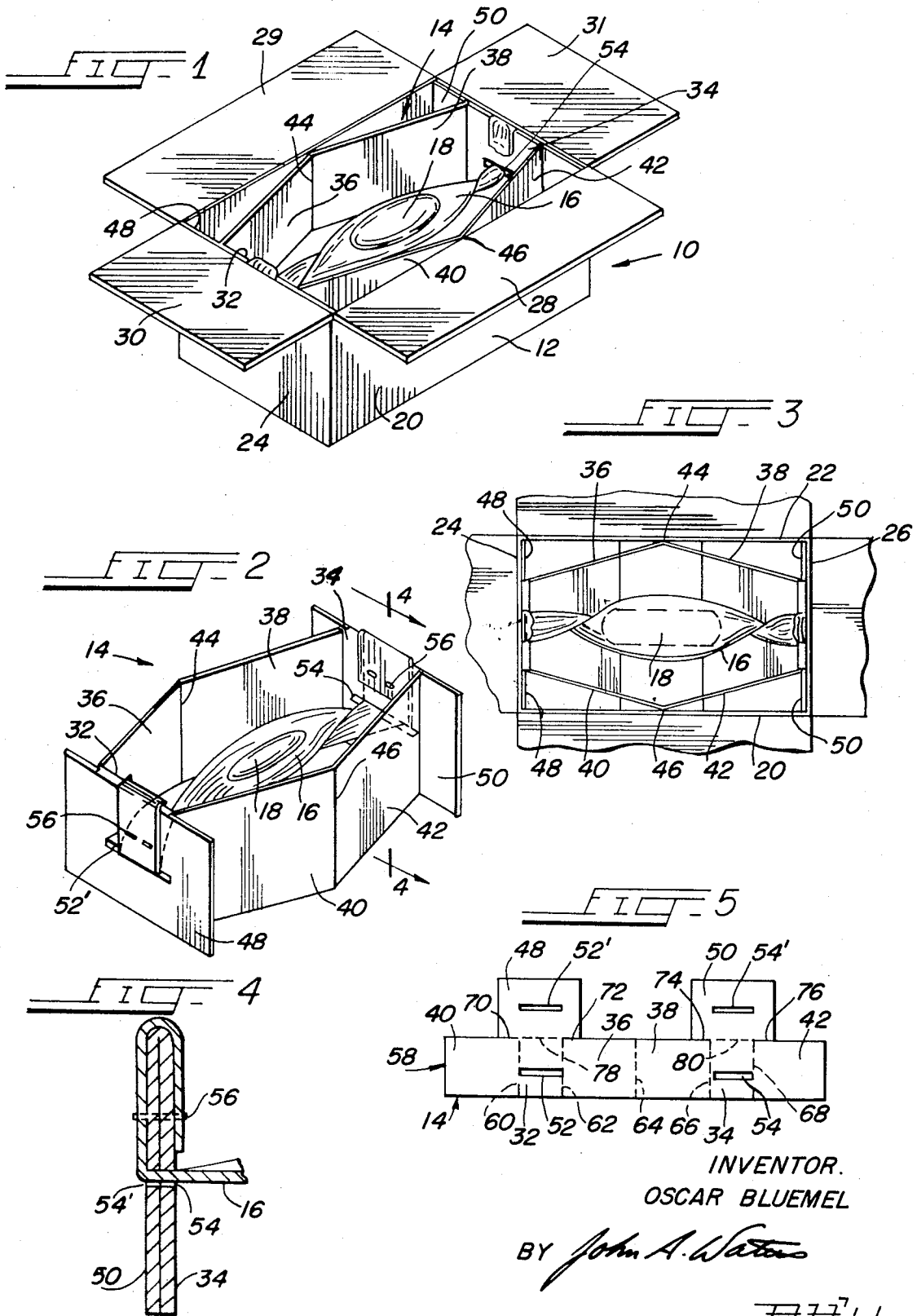

INVENTOR.
OSCAR BLUEMEL

BY *John A. Watson*

FILE

SHOCK-PROOF PACKING CONTAINER**BACKGROUND OF THE INVENTION****1. Field of the Invention**

The present invention relates to shock-proof packing 5
containers for shipping fragile articles, and, more particularly, this invention relates to shock-proof packing containers wherein fragile articles may be shipped in conventional rectangular corrugated cardboard cartons.

2. Description of the Prior Art

One method heretofore known for shipping fragile 10
articles has been to employ shipping cartons that are specifically designed and constructed for carrying fragile articles. Such containers may be effective in providing protection for the fragile articles, but they are usually constructed of special materials or require special fabrication procedures and, hence, are expensive and impractical for shipping less expensive items.

In an effort to obviate the excessive expense of specialized shipping cartons, some attempts have been made to utilize conventional rectangular cardboard cartons for shipping fragile articles. One of the methods employed to ship fragile articles in a conventional cardboard carton has been to wrap the article in a plastic 15
sling and fasten the sling across two opposite side walls of the cardboard carton, thereby positioning the article in the middle of the carton for shipping. This type of arrangement, however, does not provide any support for the cardboard carton itself and therefore does not prevent the carton from being damaged or distorted due to mishandling. Distortion or damage to the cardboard carton in turn causes the articles within to be jostled and damaged.

Another method used for shipping fragile articles in 20
a conventional cardboard carton has been to surround the articles in the carton with loose dunnage or filling materials such as shredded paper, fiberglass, or the like. The use of filling materials, however, provides only mediocre protection against shock impact and only a minimum amount of reinforcement for the outer container. Moreover, filling material is expensive and creates a waste problem for the person receiving the shipped article. Further, filling materials tend to be 25
dirty and dusty and therefore are not satisfactory for articles that must be shipped in a hygienic dust-free environment.

In order to obviate the foregoing deficiencies of the prior art, the present invention was evolved.

SUMMARY OF THE INVENTION

A shock-proof packing container constructed in accordance with the present invention comprises a rectangular outer carton, an inner support member having a polygonal cross section that fits snugly within the outer carton and bears against all four walls thereof, and a flexible sling that is attached to two opposing walls of the inner support member and extends therebetween. Fragile articles are wrapped in this sling and are thereby suspended in the interior of packing container. Locking flaps are attached to the inner support member so as to hold the inner support member in a fixed position with respect to the outer carton.

The inner support member is a polygonal member 30
having at least six sides, with two opposing sides comprising end walls which abut end walls of the outer carton. The remaining walls comprise side walls that ex-

tend outwardly from the end walls and contact the side walls of the outer carton. Preferably, the flexible sling is mounted to the inner support member by extending the ends of the sling through openings in the respective end walls of the inner support member and fastening them thereto.

The locking flaps are attached to the end walls of the inner support member and are interposed between the respective end walls of the inner support member and the outer carton. The locking flaps extend from the inner support member outwardly into contact with the side walls of the outer carton, thereby holding the inner support member in a fixed position relative to the outer 35
carton.

Preferably, the inner support member is formed from a single rectangular corrugated cardboard blank, with the locking flaps comprising raised tabs that extend upwardly from the top of the blank. Thus, the inner support member may be constructed by folding the cardboard blank into its desired polygonal structure and then folding the locking flaps downwardly over the outside of the end walls.

Several advantages are achieved with the apparatus of the present invention. First, the packaged items are resiliently suspended approximately in the middle of the container and are thus protected from damage during shipping. Further, the items to be shipped are wrapped in an air-tight plastic wrapping, which protects the contents from moisture and dust during shipping. Finally, the packing container of the present invention is very inexpensive and easy to construct and employs only conventional corrugated cardboard components.

Accordingly, it is a primary object of the present invention to provide a shock-proof packing container for fragile articles that is both inexpensive and effective.

Another object of the present invention is to provide a shock-proof packing container for fragile articles that is both dust proof and moisture proof.

Still another object of the present invention is to provide a shock-proof packing container for fragile articles which employs a conventional rectangular outer carton and requires no dunnage, filling materials, or expensive specialized apparatus for protecting the fragile articles.

A further object of the present invention is to provide a shock-proof packing container wherein fragile articles are wrapped in a flexible sling and the sling is suspended across an inner support member that provides reinforcement for the outer walls of the container.

Yet another object of the present invention is to provide a shock-proof packing container of the type above described wherein the inner support member comprises locking flaps to retain the inner support member in a fixed position within the outer carton.

Another object of the present invention is to provide a shock-proof packing container of the type above described, wherein the inner support member is constructed from a single corrugated cardboard blank.

These and other objects, advantages, and features of the present invention will hereinafter appear, and for purposes of illustration, but not of limitation, a preferred embodiment of the subject invention is described below and illustrated in the appended drawing.

BRIEF DESCRIPTION OF THE DRAWING

FIG. 1 is a perspective view of a shock-proof shipping container constructed in accordance with the present invention.

FIG. 2 is a perspective view of the inner support member and flexible sling arrangement of the present invention.

FIG. 3 is a top plan view of the shock-proof packing container of the present invention, shown with the top of the carton open.

FIG. 4 is a cross-sectional view taken along line 4—4 of FIG. 2.

FIG. 5 is a plan view of the blank from which the inner support member is formed.

DETAILED DESCRIPTION OF THE PREFERRED EMBODIMENT

Referring now to the drawings, a shock-proof packing container 10 constructed in accordance with the present invention is shown in FIG. 1. Packing container 10 comprises an outer rectangular carton 12, an inner support member 14 that fits snugly within outer carton 12, and a flexible sling 16 suspended across two opposing sides of inner support member 14. Flexible sling 16 envelops and holds in suspension a fragile article 18, which is to be shipped.

In the preferred embodiment of the subject invention, outer carton 12 is a conventional corrugated cardboard carton having side walls 20 and 22 and end walls 24 and 26. The top of outer carton 12 is closed by means of side flaps 28 and 29 and end flaps 30 and 31. Although it is one of the principal advantages of the present invention that a conventional corrugated cardboard carton may be employed as the outer carton, it is, of course, possible for the outer carton to be constructed from other types of conventional materials, as well, without departing from the spirit or scope of the present invention.

Inner support member 14 comprises a channel-shaped member having six sides, with the height of the sides being equal to the height of the walls of the outer carton. The sides of inner support member 14 comprise two opposing end walls 32 and 34, which abut end walls 24 and 26, respectively, of the outer container, and side walls 36, 38, 40, and 42. End walls 32 and 34 are narrower than end walls 24 and 26 of the outer carton and, hence, terminate in outer edges that do not extend all the way outwardly to the side walls of the outer container. Side walls 36, 38, 40, and 42 are each connected to an outer edge of one of the end walls of the inner support member and extend outwardly into contact with the corresponding side wall of the outer carton approximately at the midpoint thereof. Side walls 36 and 38 are joined along the outer edges thereof, forming an outer edge 44 that contacts side wall 22 of the outer carton. Likewise, the outer edges of side walls 40 and 42 are joined together forming outer edge 46, which contacts side wall 20 of the outer carton.

With the interior support member constructed in this manner, substantial reinforcement will be provided for the wall of the outer carton, particularly at the points where the carton is the weakest, namely, at the midpoints of the end and side walls. Because support member 14 is a polygonal figure and side walls 36, 38, 40, and 42 all contact the walls of the outer carton at skewed angles, the inner support member provides a

buttressing effect for the walls of the outer carton that would be unachievable with a mere rectangular inner support member, absent some further reinforcement of the inner support member itself.

Although the preferred embodiment of the present invention employs a hexagonal inner support member having the general shape of a diamond with truncated ends, it should be recognized that other polygonal configurations, such as an octagonal member, also could be employed without departing from the spirit and scope of the present invention. For example, with an octagonal inner support member (not shown), the two additional side walls thereof would bear against the side walls of the outer carton, instead of outer edges 44 and 46 of the hexagonal inner support member.

In addition to the polygonal channel-shaped member, the inner support member further comprises locking flaps 48 and 50, which are attached to end walls 32 and 34, respectively, and which are interposed between the end walls of the inner support member and the respective end walls 24 and 26 of the outer carton. Locking flaps 48 and 50 are flat rectangular members, which extend outwardly from the end walls of the inner support member to the side walls of the outer carton, thereby holding the end walls of the inner support member approximately in the middle of the respective end walls of the outer carton. In the preferred embodiment of the subject invention, locking flaps 48 and 50 are constructed from double-faced corrugated cardboard and are formed from the same blank as inner support member 14.

The articles to be shipped inside of the reinforced shipping container are wrapped in a flexible sling, preferably formed of a plastic sheet, such as polyethylene, and the wrapping is closed by means of tape, heat seal, or other such closure method. In order to secure the sling in place in the inner support member, the ends of the flexible sling are first passed through openings 52 and 54 formed in end walls 32 and 34, respectively, and are then passed over the top of the respective end walls and are fastened thereto by means of staples 56 or other such suitable fastening devices. Sling 16 may be twisted at each end (as shown in the drawings) after article 18 has been wrapped therein, in order to retain the article approximately in the center of the sling during shipping. The article is thus carried gently in a resilient cradle, protected from disruption by the outer carton and inner support member and insulated from shock by the gentle resilience of the sling.

In addition to the separate advantages achievable by the use of a flexible sling and a polygonal inner support member, the suspension of sling 16 between the end walls 32 and 34 of the polygonal inner support member provides yet another independent structural advantage over packing containers heretofore known. By suspending sling 16 between end walls 32 and 34, a tensile force is created on the inner support member that urges end walls inwardly toward the center of the container. This, in turn, urges outer edges 44 and 46 outwardly against side walls 20 and 22, respectively, of the outer carton. Thus, whenever a potentially damaging force is exerted against the weakest part of the outer carton (i.e., the middle of the side walls), such force will first have to overcome the outward force on edges 44 and 46 before it can deform the outer carton. This inner stress feature, therefore, provides an extra margin of

safety not found in any of the shock-proof containers of the prior art.

In this context, it should also be noted that the inherent structure of the inner support member also prevents any abuse of the above-described apparatus that might otherwise occur by fastening the flexible sling too tightly to the end walls of the inner support member. Without this inherent safeguard, it is possible that overtightening of the sling would either cause the outer carton to become deformed from within or would cause the side walls of the inner support members to collapse and permit the end walls to move inwardly toward the center of the container. As shown in FIG. 3, the side walls of the inner support member are considerably longer than the distance between the outer edges of the end walls of the inner support member and the side walls of the outer carton, thus making the right triangles formed between inner support member and the outer carton quite narrow. As a result, the force exerted by the sling on the end walls of the inner support member is directed primarily in a longitudinal direction along the respective side walls, with only a moderate amount of leverage being available for bending the side walls of the inner support member or for deflecting outwardly the side walls of the outer carton.

Because of the extra strength and the added safeguard provided by the long side walls of a hexagonal inner support member, a hexagonal inner support member is employed in the preferred practice of the present invention instead of an octagonal member, which necessarily would have shorter side walls.

Another important feature of the present invention is that interior support member 14 may be constructed out of a single corrugated cardboard blank, as shown in FIG. 5. The blank comprises an elongated rectangular sheet of corrugated cardboard 58 which is scored along vertical lines 60, 62, 64, 66, and 68, in order to form the side walls and end walls of the interior support member. The cardboard blank also comprises locking flaps 48 and 50 which extend upwardly from the long side of cardboard blank 58 (FIG. 5 orientation). The junction between locking flaps 48 and 50 and the rectangular blank 58 comprises slots 70, 72, 74, and 78 and scored lines 78 and 80. Thus, after cardboard blank 48 has been folded along the vertical scored lines shown in FIG. 5 and the outer ends of sides 40 and 42 have been joined together, flaps 48 and 50 may be folded downwardly over the outside of ends 32 and 34, respectively thereby providing means for locking the respective ends in place when the inner support member is placed in the outer carton.

Slots or openings 52 and 54 formed in the ends of inner support member 14 comprise die-cut slots 52 and 54 in the respective end walls 32 and 34 and corresponding slots 52' and 54' in the locking flaps 48 and 50. When locking flap 48 is folded downwardly over end wall 32 and locking flap 50 is folded downwardly over end wall 34, the respective openings 52 and 52' and 54 and 54' mate with each other, thus providing openings for the ends of the flexible sling to be passed therethrough.

As pointed out earlier, the shock-proof shipping container of the present invention provides numerous advantages over the shipping containers of the prior art. The present invention employs only inexpensive conventional corrugated cardboard structural members and requires no complex fabrication procedures, yet it

provides more strength and durability than any of the more complex and more expensive speciality shipping containers used in the prior art. Moreover, the present invention employs no dunnage or filling materials. Also, the items to be shipped are packaged in an airtight plastic wrapping, which protects the fragile article from moisture and dust during shipping.

A further important advantage of the present invention, as shown in FIG. 2, is that the fragile article to be shipped may be wrapped in a plastic wrapping and fastened securely to the inner support member before the inner support member is fitted into the outer cardboard carton. Thus, when the fragile article is to be unpacked, the inner support member and attached sling and fragile article may be removed gently from the outer shipping carton before the article need be released from the sling mechanism, thus facilitating a more gentle handling in unpacking the fragile article than would otherwise be possible if the sling were mounted directly to the wall of the outer carton. Moreover, the fact that no staples or other fastening devices are attached directly to the outer carton permits the reuse of the outer carton any number of times.

Those skilled in the art will appreciate the arrangements taught herein are merely exemplary of the preferred practice of the subject invention and that additional changes, modifications, and variations may be made in the arrangements shown herein without departing from the spirit and scope of the present invention.

I Claim:

1. A shock-proof packing container comprising:
 - a rectangular outer carton comprising two end walls and two side walls;
 - a polygonal inner support member that fits within the outer carton and bears against all four walls thereof, said inner support member comprising two opposing end walls that abut the two opposing end walls of the outer carton, the end walls of the inner support member being narrower than the end walls of the outer carton;
 - locking flap means adapted to hold the inner support member in a fixed position within the outer carton, said locking flap means comprising a pair of flat locking flaps attached to the respective end walls of the inner support member and interposed between the end walls of the inner support member and outer carton, said locking flaps extending outwardly into contact with the side walls of the outer carton so as to maintain the end walls of the inner support member in a fixed position relative to the outer carton; and
 - flexible sling means suspended between opposing walls of the inner support member, said flexible sling means being adapted to envelop and hold fragile articles in suspension in the interior of the container.
2. A shock-proof packing container as claimed in claim 1, wherein the flexible sling is attached to and suspended between the end walls of the inner support member.
3. A packing container as claimed in claim 2, wherein:
 - the end walls and the locking flaps have openings adjacent the midpoints thereof such that the locking flaps and end wall openings mate when the locking flaps are placed over the end walls, thereby form-

7

ing a single opening through each end of the inner support member; and
the ends of the flexible sling extend through the respective openings in the ends of the inner support member and are fastened to the inner support member. 5

4. A container as claimed in claim 3 wherein the flexible sling comprises a polyethylene wrapper in which the fragile article is wrapped, and the ends of the polyethylene wrapper are extended through the openings in the end walls of the interior support member and are folded over the top of the interior support member and are stapled thereto. 10

5. A shock-proof packing container as claimed in claim 1 wherein the inner support member is formed from a single flat piece of packing material. 15

6. A shock-proof packing container as claimed in claim 5 wherein the inner support member is formed from a single, flat corrugated cardboard blank, said blank comprising an elongated rectangular member which is provided with transverse score lines, so that the piece may be folded in order to form the polygonal inner support member, said blank further comprising two rectangular tabs attached to the long side of the elongated rectangular member along the portions thereof that form the upper edges of the end walls of the inner support member, said blank being scored along the lines of attachment of the tabs to the elongated rectangular member so that the tabs are bendable downwardly over the end walls in order to form locking flaps. 20 25 30

7. A shock-proof packing container for shipping fragile articles comprising:
a rectangular outer carton having two end walls and two side walls; 35
an inner support means adapted to fit snugly within said outer carton, said inner support means comprising a channel-shaped member having at least six sides, with said channel-shaped member comprising two opposing end walls that abut the end walls of the outer carton and side walls which extend outwardly into contact with the respective side walls of the outer carton adjacent the midpoints thereof, said inner support member further comprising locking flaps attached to each of the end walls thereof, said locking flaps being interposed between the end walls of the inner support member and the outer carton and extending outwardly from the inner support member into contact with the side walls of the outer carton, thereby holding the end walls of the inner support means in a fixed position with respect to the end walls of the packing container; and 50
a flexible sling means attached to two opposing walls of the interior support means, said flexible sling means being adapted to envelop and hold fragile articles in suspension in the interior of the container. 55

8

8. A shock-proof packing container as claimed in claim 7, wherein:
the inner support member is hexagonal; and
the flexible sling is attached to and suspended between the end walls of the inner support member.

9. A packing container as claimed in claim 8, wherein the inner support member is formed of a single sheet of flat packing material, said sheet comprising an elongated rectangular member having transverse score lines so that the member may be folded in order to form the hexagonal inner support member, said sheet further comprising rectangular tabs attached to the long side of the elongated rectangular member along the upper edge of the portion of the elongated rectangular sheet that forms the end walls of the inner support member. 15
whereby, the channel-shaped member may be formed by folding the elongated rectangular sheet in order to form the hexagonal inner support member and then folding the tabs downwardly over the end walls of the inner support means in order to form locking flaps.

10. A shock-proof packing container for packing fragile articles comprising:
a rectangular outer carton having two vertical end walls, two vertical side walls, and a top and a bottom, the top of which comprises flaps that may be opened or closed;
an inner support member adapted to fit snugly within the outer carton, said inner support member comprising:
a six-sided channel-shaped member having closed vertical sides and an open top and bottom, the sides of said channel-shaped member being equal to the height of the sides of the outer carton and comprising two opposing end walls that are narrower than and abut the end walls of the outer carton, said sides of said channel-shaped member further comprising four side walls that extend outwardly from the end walls of the inner support member and bear against the side walls of the outer carton adjacent the midpoints thereof; and locking flaps attached to the end walls of the inner support member and interposed between the respective end walls of the inner support member and the outer carton, said locking flaps extending outwardly so as to bear against the side walls of the outer carton, thereby maintaining the end walls of the inner support member in a fixed transverse position relative to the end walls of the outer carton; and
a flexible sling comprising a plastic wrapper wherein fragile articles to be shipped are securely wrapped, the ends of the flexible sling being extended respectively through openings formed in the end walls and locking flaps of the inner support member and being drawn tightly over the top edge of the end walls and stapled thereto. 20 25 30 35 40 45 50 55

* * * * *

60

65