

(19) World Intellectual Property Organization
International Bureau



(43) International Publication Date
12 May 2005 (12.05.2005)

PCT

(10) International Publication Number
WO 2005/042091 A1

(51) International Patent Classification⁷: A61N 1/368, 1/362

South First Street, #513, Minneapolis, MN 55401 (US). SPINELLI, Julio, C. [US/US]; 5612 Chatsworth Street, Shoreview, MN 55126 (US).

(21) International Application Number: PCT/US2004/036606

(74) Agents: STEFFEY, Charles, E. et al.; Schwegman, Lundberg, Woessner & Kluth, P.A., P.O. Box 2938, Minneapolis, MN 55402 (US).

(22) International Filing Date: 3 November 2004 (03.11.2004)

(25) Filing Language: English

(81) Designated States (unless otherwise indicated, for every kind of national protection available): AE, AG, AL, AM, AT, AU, AZ, BA, BB, BG, BR, BW, BY, BZ, CA, CH, CN, CO, CR, CU, CZ, DE, DK, DM, DZ, EC, EE, EG, ES, FI, GB, GD, GE, GH, GM, HR, HU, ID, IL, IN, IS, JP, KE, KG, KP, KR, KZ, LC, LK, LR, LS, LT, LU, LV, MA, MD, MG, MK, MN, MW, MX, MZ, NA, NI, NO, NZ, OM, PG, PH, PL, PT, RO, RU, SC, SD, SE, SG, SK, SL, SY, TJ, TM, TN, TR, TT, TZ, UA, UG, US, UZ, VC, VN, YU, ZA, ZM, ZW.

(26) Publication Language: English

(30) Priority Data: 10/700,368 3 November 2003 (03.11.2003) US

(71) Applicant (for all designated States except US): CARDIAC PACEMAKERS, INC. [US/US]; 4100 Hamline Avenue North, St. Paul, MN 55112 (US).

(72) Inventors; and

(84) Designated States (unless otherwise indicated, for every kind of regional protection available): ARIPO (BW, GH, GM, KE, LS, MW, MZ, NA, SD, SL, SZ, TZ, UG, ZM,

(75) Inventors/Applicants (for US only): PASTORE, Joseph, M. [US/US]; 9069 Cambridge Road, Woodbury, MN 55125 (US). HARRIS-HAJENGA, Zoe [US/US]; 401

[Continued on next page]

(54) Title: MULTI-SITE VENTRICULAR PACING THERAPY WITH PARASYMPATHETIC STIMULATION

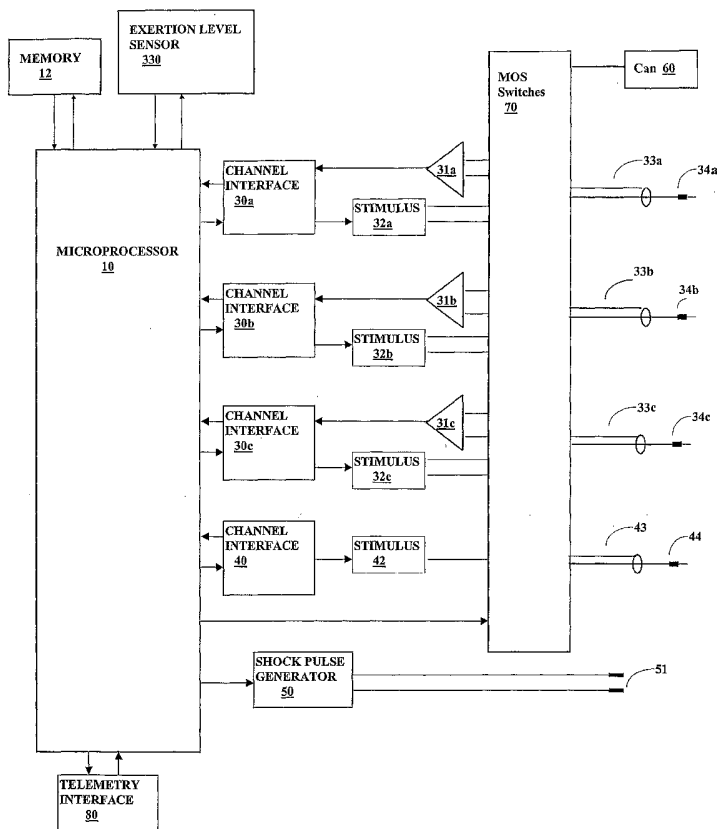

(57) Abstract: A method and device for delivering multi-site ventricular pacing therapy in conjunction with parasympathetic stimulation for reducing ventricular wall stress. Such reduction in ventricular wall stress is useful in reversing or preventing the ventricular remodeling which can occur in heart failure patients.

WO 2005/042091 A1



ZW), Eurasian (AM, AZ, BY, KG, KZ, MD, RU, TJ, TM), European (AT, BE, BG, CH, CY, CZ, DE, DK, EE, ES, FI, FR, GB, GR, HU, IE, IS, IT, LU, MC, NL, PL, PT, RO, SE, SI, SK, TR), OAPI (BF, BJ, CF, CG, CI, CM, GA, GN, GQ, GW, ML, MR, NE, SN, TD, TG).

— *before the expiration of the time limit for amending the claims and to be republished in the event of receipt of amendments*

Published:

— *with international search report*

For two-letter codes and other abbreviations, refer to the "Guidance Notes on Codes and Abbreviations" appearing at the beginning of each regular issue of the PCT Gazette.

MULTI-SITE VENTRICULAR PACING THERAPY WITH PARASYMPATHETIC STIMULATION

Field of the Invention

This patent application pertains to methods and apparatus for the treatment of cardiac disease. In particular, it relates to methods and apparatus for improving cardiac function with electro-stimulatory therapy.

Background

Implantable cardiac devices that provide electrical stimulation to selected chambers of the heart have been developed in order to treat a number of cardiac disorders. A pacemaker, for example, is a device which paces the heart with timed pacing pulses, most commonly for the treatment of bradycardia where the ventricular rate is too slow. Atrio-ventricular conduction defects (i.e., AV block) and sick sinus syndrome represent the most common causes of bradycardia for which permanent pacing may be indicated. If functioning properly, the pacemaker makes up for the heart's inability to pace itself at an appropriate rhythm in order to meet metabolic demand by enforcing a minimum heart rate. Implantable devices may also be used to treat cardiac rhythms that are too fast, with either anti-tachycardia pacing or the delivery of electrical shocks to terminate atrial or ventricular fibrillation.

Implantable devices have also been developed that affect the manner and degree to which the heart chambers contract during a cardiac cycle in order to promote the efficient pumping of blood. The heart pumps more effectively when the chambers contract in a coordinated manner, a result normally provided by the specialized conduction pathways in both the atria and the ventricles that enable the rapid conduction of excitation (i.e., depolarization) throughout the myocardium. These pathways conduct excitatory impulses from the sino-atrial node to the atrial myocardium, to the atrio-ventricular node, and thence to the ventricular myocardium to result in a coordinated contraction of both atria and both ventricles. This both synchronizes the contractions of the muscle fibers of each chamber and synchronizes

the contraction of each atrium or ventricle with the contralateral atrium or ventricle. Without the synchronization afforded by the normally functioning specialized conduction pathways, the heart's pumping efficiency is greatly diminished. Pathology of these conduction pathways and other inter-ventricular or intra-ventricular conduction deficits can be a causative factor in heart failure, which refers to a clinical syndrome in which an abnormality of cardiac function causes cardiac output to fall below a level adequate to meet the metabolic demand of peripheral tissues. In order to treat these problems, implantable cardiac devices have been developed that provide appropriately timed electrical stimulation to one or more heart chambers in an attempt to improve the coordination of atrial and/or ventricular contractions, termed cardiac resynchronization therapy (CRT). Ventricular resynchronization is useful in treating heart failure because, although not directly inotropic, resynchronization can result in a more coordinated contraction of the ventricles with improved pumping efficiency and increased cardiac output. Currently, a most common form of CRT applies stimulation pulses to both ventricles, either simultaneously or separated by a specified biventricular offset interval, and after a specified atrio-ventricular delay interval with respect to the detection an intrinsic atrial contraction.

One physiological compensatory mechanism that acts to increase cardiac output in heart failure patients is due to so-called backward failure which increases the diastolic filling pressure of the ventricles and thereby increases the preload (i.e., the degree to which the ventricles are stretched by the volume of blood in the ventricles at the end of diastole). An increase in preload causes an increase in stroke volume during systole, a phenomena known as the Frank-Starling principle. Thus, heart failure can be at least partially compensated by this mechanism but at the expense of possible pulmonary and/or systemic congestion. When the ventricles are stretched due to the increased preload over a period of time, however, the ventricles become dilated. The enlargement of the ventricular volume causes increased ventricular wall stress at a given systolic pressure. Along with the increased pressure-volume work done by the ventricle, this acts as a stimulus for hypertrophy of the ventricular myocardium which leads to alterations in cellular structure, a process referred to as ventricular remodeling.

Hypertrophy can increase systolic pressures but also decreases the compliance of the ventricles and hence increases diastolic filling pressure to result in even more congestion. It also has been shown that the sustained stresses causing hypertrophy may induce apoptosis (i.e., programmed cell death) of cardiac muscle cells and eventual wall thinning which causes further deterioration in cardiac function. Thus, although ventricular dilation and hypertrophy may at first be compensatory and increase cardiac output, the processes ultimately result in both systolic and diastolic dysfunction. It has been shown that the extent of ventricular remodeling is positively correlated with increased mortality in CHF patients. It is with reversing such ventricular remodeling that the present invention is primarily concerned.

Summary

The present invention relates to a method and device for delivering multi-site ventricular pacing therapy in conjunction with stimulation of parasympathetic nerves innervating the heart. Such parasympathetic stimulation acts to decrease the stresses experienced by the ventricular walls during systole so as to prevent or reverse the cardiac remodeling which can occur in heart failure patients. The parasympathetic stimulation may be delivered by an implantable cardiac device via a bipolar electrode incorporated into a lead adapted for transvenous insertion, such as into the superior or inferior vena cava. In order to counteract a tendency of parasympathetic stimulation to reduce cardiac output, the delivery of parasympathetic stimulation may be modulated in accordance with the patient's exertion level and/or a sensed parameter related to cardiac output.

Brief Description of the Drawings

Fig. 1 is a system diagram of a cardiac device configured for multi-site stimulation and sensing.

Fig. 2 illustrates an exemplary algorithm for implementing the invention.

Detailed Description

One example of cardiac function therapy which may be delivered by an implantable cardiac device is CRT. In ventricular resynchronization therapy, the ventricles are paced at more than one site in order to cause a spread of excitation that results in a more coordinated contraction and thereby overcome interventricular or intraventricular conduction defects. Biventricular pacing is one example of resynchronization therapy in which both ventricles are paced in order to synchronize their respective contractions. Resynchronization therapy may also involve multi-site pacing applied to only one chamber. For example, a ventricle may be paced at multiple sites with excitatory stimulation pulses in order to produce multiple waves of depolarization that emanate from the pacing sites. This may produce a more coordinated contraction of the ventricle and thereby compensate for intraventricular conduction defects that may exist.

Another type of cardiac function therapy is stress reduction pacing. Stress reduction pacing uses multi-site pacing in order to change the distribution of wall stress experienced by the ventricle during the cardiac pumping cycle. The degree to which a heart muscle fiber is stretched before it contracts is termed the preload. The maximum tension and velocity of shortening of a muscle fiber increases with increasing preload. When a myocardial region contracts late relative to other regions, the contraction of those opposing regions stretches the later contracting region and increases the preload. The degree of tension or stress on a heart muscle fiber as it contracts is termed the afterload. Because pressure within the ventricles rises rapidly from a diastolic to a systolic value as blood is pumped out into the aorta and pulmonary arteries, the part of the ventricle that first contracts due to an excitatory stimulation pulse does so against a lower afterload than does a part of the ventricle contracting later. Thus a myocardial region which contracts later than other regions is subjected to both an increased preload and afterload. This situation is created frequently by the ventricular conduction delays associated with heart failure and ventricular dysfunction. The heart's initial physiological response to the uneven stress resulting from an increased preload and afterload is compensatory hypertrophy in those

later contracting regions of the myocardium. In the later stages of remodeling, the regions may undergo atrophic changes with wall thinning due to the increased stress, and the extent of remodeling is positively correlated with mortality in heart failure patients. The parts of the myocardium which contract earlier in the cycle, on the other hand, are subjected to less stress and are less likely to undergo hypertrophic remodeling. This phenomenon may be used to cause reversal of remodeling by pacing one or more sites in a ventricle (or an atrium) with one or more excitatory stimulation pulses during a cardiac cycle with a specified pulse output sequence. The pace or paces are delivered in a manner that excites a previously stressed and remodeled region of the myocardium earlier during systole so that it experiences less afterload and preload. The pre-excitation of the remodeled region relative to other regions unloads the region from mechanical stress and allows reversal of remodeling to occur.

Heart failure patients may thus benefit from multi-site ventricular pacing for the purpose of improving cardiac output with more coordinated contractions and/or for the purpose of reducing ventricular wall stresses. A further decrease in ventricular wall stress may be obtained by, in conjunction with multi-site ventricular pacing, electrically stimulating parasympathetic nerves which innervate the heart. Sympathetic and parasympathetic nerves act on the heart via beta-adrenergic and muscarinic receptors, respectively, to affect both heart rate and myocardial contractility. A predominance of sympathetic over parasympathetic stimulation of the heart, for example, increases both intrinsic heart rate (via receptors at the sino-atrial node) and the strength of ventricular contractions. Stimulation of cardiac parasympathetic nerves, on the other hand, decreases myocardial contractility and hence reduces ventricular wall stresses. When delivered in conjunction with multi-site ventricular pacing for the treatment of heart failure, such parasympathetic stimulation can thus be beneficial in reversing or preventing cardiac remodeling.

Parasympathetic stimulation may be delivered by an implantable cardiac device via a bipolar electrode incorporated into a lead adapted for transvenous insertion, such as into the superior or inferior vena cava. In another embodiment, the bipolar electrode may be incorporated within a shock lead normally used for delivering

cardioversion/defibrillation shocks to the heart. A pulse generator in the device then delivers electrical stimulation via the bipolar electrode to the inner surface of the blood vessel and stimulates the parasympathetic nerves that run adjacent thereto. Alternative sites for stimulating parasympathetic nerves also exist such as the atrial fat pad and others well-known to those of skill in the art. The electrical stimulation may be, for example, in the form of a square-wave or truncated exponential pulse train at a frequency of between 5 and 50 Hz. The result of such electrical stimulation is a slowing of sinus rhythm due to increased parasympathetic activity acting on the sinoatrial node as well as a negative inotropic effect which decreases ventricular wall stresses during systole.

Parasympathetic stimulation causes both a slowing of the intrinsic heart rate and a decrease in myocardial contractility, both of which tend to decrease cardiac output. Such a result may be undesirable in a heart failure patient, the beneficial effects on remodeling notwithstanding. An implantable device for delivering the parasympathetic stimulation in conjunction with multi-site ventricular pacing therapy, however, may counteract this undesirable result by several means, any or all of which may be employed. Firstly, if the multi-site ventricular pacing therapy is delivered in accordance with a demand pacing mode which enforces a minimum heart rate, no slowing of the heart rate occurs. Secondly, the decrease in cardiac output which would otherwise be brought about by a decrease in cardiac output may be compensated for by improved coordination of ventricular contractions due to the multi-site pacing. Thirdly, the device may be programmed to modulate the delivery of parasympathetic stimulation in accordance with a sensed parameter which reflects the patient's demand for cardiac output and/or the patient's actual cardiac output. In one embodiment, the device measures the patient's exertion level with a minute ventilation sensor or an accelerometer and delivers parasympathetic stimulation only when the measured exertion level is below a specified limit value. Alternatively, the extent of parasympathetic stimulation may be made to vary inversely with the measured exertion level. In another embodiment, the device measures the patient's cardiac output and delivers parasympathetic stimulation either in proportion to the measured

cardiac output or only when the cardiac output exceeds a specified limit value. In another embodiment, measurements of cardiac output and exertion level are combined to compute a parameter which indicates the adequacy of the measured cardiac output. For example, a look-up table may be used to match a particular exertion level with a minimum cardiac output considered to be adequate. The device may then be programmed to deliver parasympathetic stimulation only if cardiac output is at a level considered to be adequate to meet metabolic demand.

What follows is a description of an exemplary implantable cardiac device which may be used to practice the invention as described above. An exemplary algorithm by which the device may implement parasympathetic stimulation is also described.

1. Exemplary device description

An implantable cardiac device is typically placed subcutaneously or submuscularly in a patient's chest with leads threaded intravenously into the heart to connect the device to electrodes used for sensing and stimulation. Leads may also be positioned on the epicardium by various means. A programmable electronic controller causes the stimulus pulses to be output in response to lapsed time intervals and sensed electrical activity (i.e., intrinsic heart beats not as a result of a stimulus pulse). The device senses intrinsic cardiac electrical activity by means of internal electrodes disposed near the chamber to be sensed. A depolarization wave associated with an intrinsic contraction of the atria or ventricles that is detected by the device is referred to as an atrial sense or ventricular sense, respectively. In order to cause such a contraction in the absence of an intrinsic beat, a stimulus pulse (a.k.a. a pace or pacing pulse when delivered in order to enforce a certain rhythm) with energy above a certain threshold is delivered to the chamber.

Fig. 1 shows a system diagram of a microprocessor-based cardiac device suitable for practicing the present invention. The device is equipped with multiple sensing and pacing channels which may be physically configured to sense and/or pace multiple sites in the atria or the ventricles. The device shown in Fig. 1 can be

configured for cardiac resynchronization pacing of the atria or ventricles and/or for myocardial stress reduction pacing such that one or more cardiac sites are sensed and/or paced in a manner that pre-excites at least one region of the myocardium. The multiple sensing/pacing channels may be configured, for example, with one atrial and two ventricular sensing/stimulation channels for delivering biventricular resynchronization therapy, with the atrial sensing/pacing channel used to deliver biventricular resynchronization therapy in an atrial tracking mode as well as to pace the atria if required. The controller 10 of the device is a microprocessor which communicates with a memory 12 via a bidirectional data bus. The memory 12 typically comprises a ROM (read-only memory) for program storage and a RAM (random-access memory) for data storage. The controller could be implemented by other types of logic circuitry (e.g., discrete components or programmable logic arrays) using a state machine type of design, but a microprocessor-based system is preferable. As used herein, the term "circuitry" should be taken to refer to either discrete logic circuitry or to the programming of a microprocessor.

Shown in the figure are three exemplary sensing and pacing channels designated "a" through "c" comprising bipolar leads with ring electrodes 34a-c and tip electrodes 33a-c, sensing amplifiers 31a-c, pulse generators 32a-c, and channel interfaces 30a-c. Each channel thus includes a pacing channel made up of the pulse generator connected to the electrode and a sensing channel made up of the sense amplifier connected to the electrode. The channel interfaces 30a-c communicate bidirectionally with microprocessor 10, and each interface may include analog-to-digital converters for digitizing sensing signal inputs from the sensing amplifiers and registers that can be written to by the microprocessor in order to output pacing pulses, change the pacing pulse amplitude, and adjust the gain and threshold values for the sensing amplifiers. The sensing circuitry of the pacemaker detects a chamber sense, either an atrial sense or ventricular sense, when an electrogram signal (i.e., a voltage sensed by an electrode representing cardiac electrical activity) generated by a particular channel exceeds a specified detection threshold. Pacing algorithms used in particular pacing modes employ such senses to trigger or inhibit pacing, and the intrinsic atrial

and/or ventricular rates can be detected by measuring the time intervals between atrial and ventricular senses, respectively. A stimulation channel is also provided for delivering parasympathetic stimulation which includes a bipolar lead with a ring electrode 44 and a tip electrode 43, a pulse generator 42, and a channel interfaces 40.

The electrodes of each bipolar lead are connected via conductors within the lead to a MOS switching network 70 controlled by the microprocessor. The switching network is used to switch the electrodes to the input of a sense amplifier in order to detect intrinsic cardiac activity and to the output of a pulse generator in order to deliver a pacing pulse. The switching network also enables the device to sense or pace either in a bipolar mode using both the ring and tip electrodes of a lead or in a unipolar mode using only one of the electrodes of the lead with the device housing or can 60 serving as a ground electrode. A shock pulse generator 50 is also interfaced to the controller for delivering a defibrillation shock via a pair of shock electrodes 51 to the atria or ventricles upon detection of a shockable tachyarrhythmia.

The controller 10 controls the overall operation of the device in accordance with programmed instructions stored in memory, including controlling the delivery of paces via the pacing channels, interpreting sense signals received from the sensing channels, and implementing timers for defining escape intervals and sensory refractory periods. An exertion level sensor 330 (e.g., an accelerometer, a minute ventilation sensor, or other sensor that measures a parameter related to metabolic demand) enables the controller to adapt the pacing rate in accordance with changes in the patient's physical activity and, as described above, enables the controller to modulate the delivery of parasympathetic stimulation. A telemetry interface 80 is also provided which enables the controller to communicate with an external programmer.

In one embodiment, the exertion level sensor is a minute ventilation sensor which includes an exciter and an impedance measuring circuit. The exciter supplies excitation current of a specified amplitude (e.g., as a pulse waveform with constant amplitude) to excitation electrodes that are disposed in the thorax. Voltage sense electrodes are disposed in a selected region of the thorax so that the potential difference between the electrodes while excitation current is supplied is representative

of the transthoracic impedance between the voltage sense electrodes. The conductive housing or can may be used as one of the voltage sense electrodes. The impedance measuring circuitry processes the voltage sense signal from the voltage sense electrodes to derive the impedance signal. Further processing of the impedance signal allows the derivation of signal representing respiratory activity and/or cardiac blood volume, depending upon the location the voltage sense electrodes in the thorax. (See, e.g., U.S. Patent Nos. 5,190,035 and 6,161,042, assigned to the assignee of the present invention and hereby incorporated by reference.) If the impedance signal is filtered to remove the respiratory component, the result is a signal that is representative of blood volume in the heart at any point in time, thus allowing the computation of stroke volume and, when combined with heart rate, computation of cardiac output. The stroke volume integrated over time (or averaged and multiplied by heart rate) gives the patient's cardiac output. A look-up table or other function may be used to compute what cardiac output is considered adequate for a given exertion level. As described above, a measurement of cardiac output or a determination of the adequacy of the cardiac output may be used by the device to modulate the delivery of parasympathetic stimulation.

The controller is capable of operating the device in a number of programmed pacing modes which define how pulses are output in response to sensed events and expiration of time intervals. Most pacemakers for treating bradycardia are programmed to operate synchronously in a so-called demand mode where sensed cardiac events occurring within a defined interval either trigger or inhibit a pacing pulse. Inhibited demand pacing modes utilize escape intervals to control pacing in accordance with sensed intrinsic activity such that a pacing pulse is delivered to a heart chamber during a cardiac cycle only after expiration of a defined escape interval during which no intrinsic beat by the chamber is detected. Escape intervals for ventricular pacing can be restarted by ventricular or atrial events, the latter allowing the pacing to track intrinsic atrial beats. Cardiac function therapy, whether for the purpose of cardiac resynchronization or for reversal of remodeling, is most conveniently delivered in conjunction with a bradycardia pacing mode where, for

example, multiple excitatory stimulation pulses are delivered to multiple sites during a cardiac cycle in order to both pace the heart in accordance with a bradycardia mode and provide pre-excitation of selected sites.

A particular pacing mode for delivering cardiac function therapy, whether for stress reduction or resynchronization, includes a defined pulse output configuration and pulse output sequence, where the pulse output configuration specifies a specific subset of the available electrodes to be used for delivering pacing pulses and the pulse output sequence specifies the timing relations between the pulses. The pulse output configuration is defined by the controller selecting particular pacing channels for use in outputting pacing pulses and by selecting particular electrodes for use by the channel with switch matrix 70. The pulse output configuration and sequence which optimally effects reverse remodeling by selectively reducing myocardial wall stress may or may not be the optimum pulse output configuration and sequence for maximizing hemodynamic performance by resynchronizing ventricular contractions. For example, a more hemodynamically effective contraction may be obtained by exciting all areas of the myocardium simultaneously, which may not effectively promote reversal of the hypertrophy or remodeling. In that instance, however, delivery of parasympathetic stimulation in conjunction with the multi-site pacing may reduce ventricular wall stresses while still maintaining adequate cardiac output.

b. Exemplary algorithm

An exemplary algorithm is described below which could be applied in the case of a heart failure patient whose cardiac output is inadequate because of a conduction deficit and who is at risk for ventricular remodeling. Simply providing parasympathetic stimulation to reduce ventricular wall stress would lessen the risk of remodeling but could also further decrease the patient's already inadequate cardiac output. By combining parasympathetic stimulation with multi-site ventricular resynchronization pacing (e.g., biventricular pacing), however, the patient's ventricular function can be improved so as to allow the parasympathetic stimulation without adversely affecting cardiac output. In order to further insure that the patient's cardiac

output remains adequate, measurements of cardiac output and exertion level can be made by the implantable device with the adequacy of the cardiac output then determined from an appropriate mapping function. Delivery of parasympathetic stimulation can then be delivered or not based upon this determination.

Fig. 2 illustrates an exemplary algorithm for delivering parasympathetic stimulation in conjunction with multi-site ventricular pacing as could be implemented by appropriate programming of the implantable device controller. The algorithm is performed concurrently with the delivery of ventricular resynchronization pacing therapy. Starting at step 200, the device measures cardiac output CO by the impedance technique described above. At step 201, the patient's exertion level EL is measured by measuring either minute ventilation or body acceleration. The device then maps the measured exertion level EL to a cardiac output ACO which would be considered adequate for that exertion level at step 202. At step 203, the measured cardiac output CO is compared with the computed adequate cardiac output ACO. If the measured cardiac output is adequate (i.e., if $CO \geq ACO$ plus a possible safety margin), parasympathetic stimulation is delivered at step 204.

Although the invention has been described in conjunction with the foregoing specific embodiments, many alternatives, variations, and modifications will be apparent to those of ordinary skill in the art. Such alternatives, variations, and modifications are intended to fall within the scope of the following appended claims.

What is claimed is:

1. An implantable device for delivering cardiac function therapy to a patient, comprising:

a plurality of pacing channels for delivering pacing pulses to multiple ventricular sites;

a parasympathetic stimulation channel for stimulating parasympathetic nerves innervating the heart;

a controller for controlling the delivery of pacing pulses to the multiple ventricular sites during a cardiac cycle in accordance with a programmed pacing mode;

wherein the controller is programmed to deliver multi-site ventricular pacing therapy in conjunction with parasympathetic stimulation for reducing ventricular wall stress.

2. The device of claim 1 further comprising a sensor for measuring cardiac output and wherein the controller is programmed to modulate the delivery of parasympathetic stimulation in accordance with the measured cardiac output.

3. The device of claim 2 wherein the cardiac output sensor is a trans-thoracic impedance measuring circuit.

4. The device of claim 2 wherein the controller is programmed to deliver parasympathetic stimulation only when cardiac output is above a specified limit value.

5. The device of claim 2 wherein the controller is programmed to modulate the delivery of parasympathetic stimulation in accordance with the measured cardiac output.

6. The device of any of claims 1 through 5 further comprising an exertion level sensor for measuring the patient's exertion level and wherein the controller is

programmed to modulate the delivery of parasympathetic stimulation in accordance with the measured exertion level.

7. The device of claim 6 wherein the controller is programmed to deliver parasympathetic stimulation only when the measured exertion level is below a specified limit value.

8. The device of claim 1 further comprising:
an exertion level sensor for measuring the patient's exertion level;
a sensor for measuring cardiac output; and,
wherein the controller is programmed to modulate the delivery of parasympathetic stimulation in accordance with the measured exertion level and measured cardiac output.

9. The device of claim 7 wherein the controller is programmed to deliver parasympathetic stimulation only when a computed function of the currently measured cardiac output and exertion level indicates that cardiac output is adequate.

10. The device of claim of any of claims 6 through 9 wherein the exertion level sensor is a minute ventilation sensor.

11. The device of any of claims 6 through 9 wherein the exertion level sensor is an accelerometer.

12. The device of any of claims 1 through 11 wherein the parasympathetic stimulation channel includes a bipolar electrode incorporated into a lead adapted for transvenous insertion.

13. The device any of claims 1 through 11 wherein the parasympathetic stimulation channel includes a bipolar electrode incorporated within a shock lead normally used for delivering cardioversion/defibrillation shocks to the heart.

14. The device of any of claims 1 through 13 wherein the parasympathetic stimulation channel delivers parasympathetic stimulation in the form of a square-wave pulse train.

15. The device of any of claims 1 through 13 wherein the parasympathetic stimulation channel delivers parasympathetic stimulation in the form of a truncated exponential pulse train.

16. The device any of claims 1 through 15 wherein the parasympathetic stimulation channel delivers parasympathetic stimulation at a frequency of between 5 and 50 Hz.

17. The device any of claims 1 through 16 wherein the multi-site ventricular pacing therapy is delivered in accordance with a demand pacing mode which enforces a minimum ventricular rate.

18. The device any of claims 1 through 17 further comprising an atrial pacing channel and wherein the multi-site ventricular pacing therapy is delivered in accordance with a demand pacing mode which enforces a minimum atrial rate by atrial pacing.

19. The device of any of claims 1 through 18 further comprising an atrial sensing channel and wherein the multi-site ventricular pacing therapy is delivered in accordance with an atrial tracking pacing mode.

20. The device any of claims 1 through 19 wherein the multi-site ventricular pacing therapy is biventricular pacing with a specified offset.

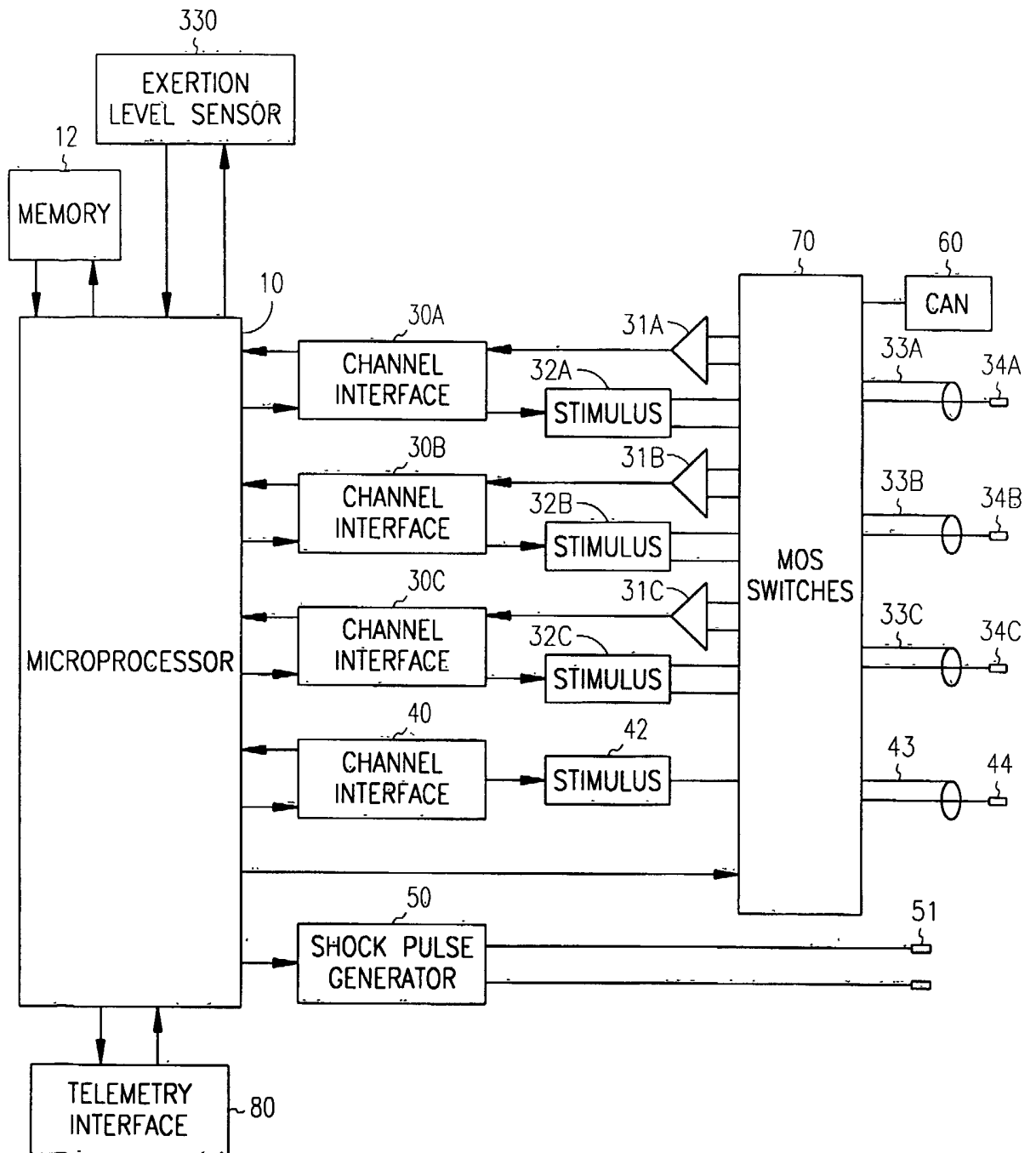

FIG. 1

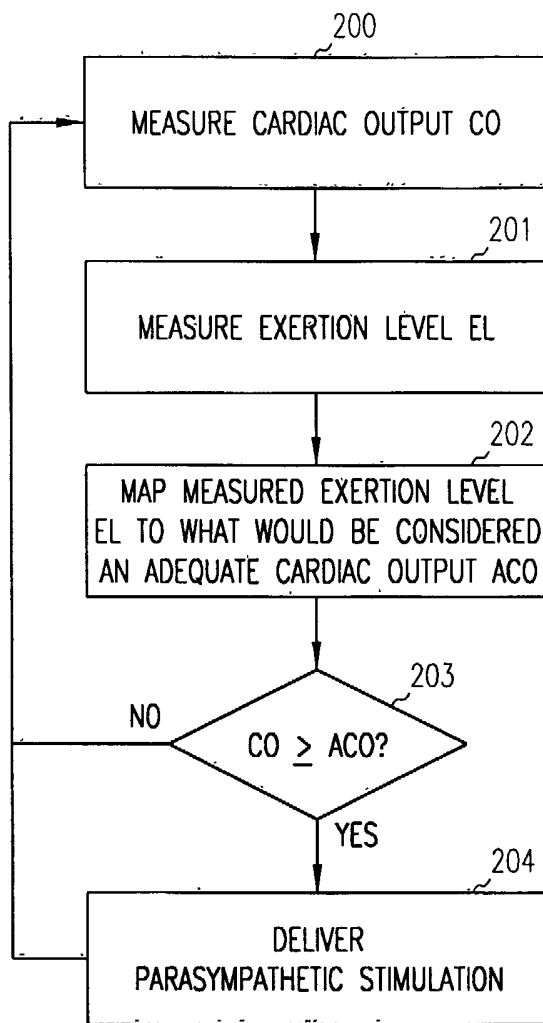

FIG. 2

INTERNATIONAL SEARCH REPORT

International Application No
PCT/US2004/036606

A. CLASSIFICATION OF SUBJECT MATTER
IPC 7 A61N1/368 A61N1/362

According to International Patent Classification (IPC) or to both national classification and IPC

B. FIELDS SEARCHED

Minimum documentation searched (classification system followed by classification symbols)
IPC 7 A61N

Documentation searched other than minimum documentation to the extent that such documents are included in the fields searched

Electronic data base consulted during the international search (name of data base and, where practical, search terms used)

EPO-Internal

C. DOCUMENTS CONSIDERED TO BE RELEVANT

Category °	Citation of document, with indication, where appropriate, of the relevant passages	Relevant to claim No.
Y	WO 01/24876 A (CARDIAC PACEMAKERS, INC) 12 April 2001 (2001-04-12) the whole document	1-6,8, 11-13, 17-20
Y	WO 01/76689 A (CARDIAC PACEMAKERS, INC) 18 October 2001 (2001-10-18) the whole document	1-6,8, 11-13, 17-20
A	US 2003/105493 A1 (SALO RODNEY W) 5 June 2003 (2003-06-05) the whole document	1-11
A	US 6 285 907 B1 (KRAMER ANDREW P ET AL) 4 September 2001 (2001-09-04) the whole document	1-12, 18-20
	----- -/--	

Further documents are listed in the continuation of box C.

Patent family members are listed in annex.

° Special categories of cited documents :

- *A* document defining the general state of the art which is not considered to be of particular relevance
- *E* earlier document but published on or after the international filing date
- *L* document which may throw doubts on priority claim(s) or which is cited to establish the publication date of another citation or other special reason (as specified)
- *O* document referring to an oral disclosure, use, exhibition or other means
- *P* document published prior to the international filing date but later than the priority date claimed

- *T* later document published after the international filing date or priority date and not in conflict with the application but cited to understand the principle or theory underlying the invention
- *X* document of particular relevance; the claimed invention cannot be considered novel or cannot be considered to involve an inventive step when the document is taken alone
- *Y* document of particular relevance; the claimed invention cannot be considered to involve an inventive step when the document is combined with one or more other such documents, such combination being obvious to a person skilled in the art.
- *&* document member of the same patent family

Date of the actual completion of the international search

1 March 2005

Date of mailing of the international search report

10/03/2005

Name and mailing address of the ISA

European Patent Office, P.B. 5818 Patentlaan 2
NL - 2280 HV Rijswijk
Tel. (+31-70) 340-2040, Tx. 31 651 epo nl,
Fax: (+31-70) 340-3016

Authorized officer

Ferrigno, A

INTERNATIONAL SEARCH REPORT

International Application No
PCT/US2004/036606

C.(Continuation) DOCUMENTS CONSIDERED TO BE RELEVANT

Category °	Citation of document, with indication, where appropriate, of the relevant passages	Relevant to claim No.
A	US 6 411 845 B1 (MOWER MORTON M) 25 June 2002 (2002-06-25) the whole document -----	1,14-16
A	EP 0 547 734 A (TELECTRONICS N.V; TELECTRONICS NV) 23 June 1993 (1993-06-23) the whole document -----	1
A	US 2002/026222 A1 (SCHAUERTE PATRICK ET AL) 28 February 2002 (2002-02-28) the whole document -----	1

INTERNATIONAL SEARCH REPORT

Information on patent family members

International Application No

PCT/US2004/036606

Patent document cited in search report		Publication date	Patent family member(s)	Publication date
WO 0124876	A	12-04-2001	US 6272377 B1	07-08-2001
			AT 273043 T	15-08-2004
			AU 7728700 A	10-05-2001
			DE 60012951 D1	16-09-2004
			EP 1218060 A1	03-07-2002
			WO 0124876 A1	12-04-2001
			US 2002120306 A1	29-08-2002
			US 2003055461 A1	20-03-2003
			US 2001020136 A1	06-09-2001
			US 2002016550 A1	07-02-2002
			WO 0176689	A
AT 288777 T	15-02-2005			
AU 5759001 A	23-10-2001			
EP 1272251 A2	08-01-2003			
WO 0176689 A2	18-10-2001			
US 2004030357 A1	12-02-2004			
US 2003105493	A1	05-06-2003		
			EP 1453572 A2	08-09-2004
			WO 03047686 A2	12-06-2003
US 6285907	B1	04-09-2001	AU 5032500 A	12-12-2000
			AU 5146900 A	12-12-2000
			AU 5147500 A	12-12-2000
			AU 5276700 A	12-12-2000
			EP 1185335 A1	13-03-2002
			JP 2003500124 T	07-01-2003
			WO 0071200 A1	30-11-2000
			WO 0071203 A1	30-11-2000
			WO 0071201 A1	30-11-2000
			WO 0071202 A1	30-11-2000
			US 2001016759 A1	23-08-2001
US 6411845	B1	25-06-2002	AU 749615 B2	27-06-2002
			AU 2981499 A	20-09-1999
			BR 9908465 A	14-11-2000
			CA 2321554 A1	10-09-1999
			DE 1059963 T1	06-09-2001
			EA 3873 B1	30-10-2003
			EP 1059963 A1	20-12-2000
			HU 0100849 A2	28-06-2001
			JP 2003517327 T	27-05-2003
			NO 20004394 A	04-09-2000
			NZ 506533 A	29-04-2003
			PL 342657 A1	02-07-2001
			SK 13212000 A3	12-02-2001
			EP 0547734	A
DE 69225119 D1	20-05-1998			
DE 69225119 T2	17-09-1998			
EP 0547734 A2	23-06-1993			
US 2002026222	A1	28-02-2002	EP 1106206 A2	13-06-2001