



(51) International Patent Classification:

B07C 1/02 (2006.01) *G05D 1/02* (2006.01)
B61L 27/04 (2006.01) *G06F 7/00* (2006.01)
B65H 29/58 (2006.01)

(21) International Application Number:

PCT/US2017/034445

(22) International Filing Date:

25 May 2017 (25.05.2017)

(25) Filing Language:

English

(26) Publication Language:

English

(30) Priority Data:

15/166,370 27 May 2016 (27.05.2016) US

(72) Inventor; and

(71) Applicant: **WERNERSBACH, Glen, C.** [US/US]; 6372 Turpin Hill Drive, Cincinnati, OH 45244 (US).

(74) Agent: **SMITH, Mark, F.**; 905 Ohio Pike, Cincinnati, OH 45245 (US).

(81) Designated States (unless otherwise indicated, for every kind of national protection available): AE, AG, AL, AM, AO, AT, AU, AZ, BA, BB, BG, BH, BN, BR, BW, BY, BZ, CA, CH, CL, CN, CO, CR, CU, CZ, DE, DJ, DK, DM, DO, DZ, EC, EE, EG, ES, FI, GB, GD, GE, GH, GM, GT, HN, HR, HU, ID, IL, IN, IR, IS, JP, KE, KG, KH, KN, KP, KR,

KW, KZ, LA, LC, LK, LR, LS, LU, LY, MA, MD, ME, MG, MK, MN, MW, MX, MY, MZ, NA, NG, NI, NO, NZ, OM, PA, PE, PG, PH, PL, PT, QA, RO, RS, RU, RW, SA, SC, SD, SE, SG, SK, SL, SM, ST, SV, SY, TH, TJ, TM, TN, TR, TT, TZ, UA, UG, US, UZ, VC, VN, ZA, ZM, ZW.

(84) Designated States (unless otherwise indicated, for every kind of regional protection available): ARIPO (BW, GH, GM, KE, LR, LS, MW, MZ, NA, RW, SD, SL, ST, SZ, TZ, UG, ZM, ZW), Eurasian (AM, AZ, BY, KG, KZ, RU, TJ, TM), European (AL, AT, BE, BG, CH, CY, CZ, DE, DK, EE, ES, FI, FR, GB, GR, HR, HU, IE, IS, IT, LT, LU, LV, MC, MK, MT, NL, NO, PL, PT, RO, RS, SE, SI, SK, SM, TR), OAPI (BF, BJ, CF, CG, CI, CM, GA, GN, GQ, GW, KM, ML, MR, NE, SN, TD, TG).

Declarations under Rule 4.17:

— of inventorship (Rule 4.17(iv))

Published:

— with international search report (Art. 21(3))

(54) Title: MOVER SYSTEM

FIG. 1

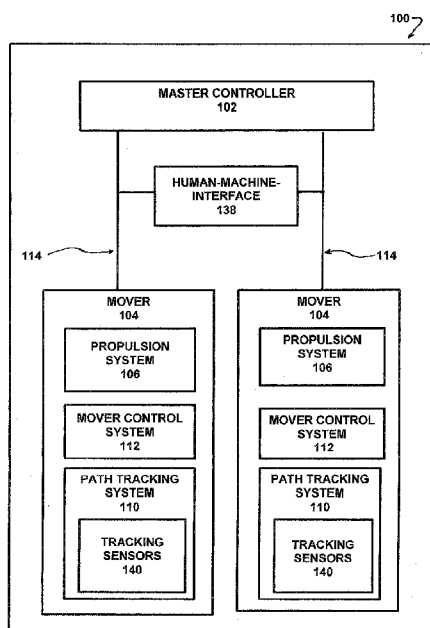

(57) Abstract: A moving system comprising a master controller for monitoring and controlling a master operation comprising one or more individual movers such that each mover arrives at predefined end point at selected times. Each mover includes a mover control system that interacts with the master controller and has a predefined virtual vector path with one or more defined end points. The predefined virtual vector path comprises a plurality of discrete points, wherein each discrete point has a vector axis for use by the master controller and the mover control system to direct the mover to move such that it arrives at each defined end point at a selected time. In operation, the master controller functions to modify the predefined virtual path and sends commands to the mover control system in response to changes in the master operations.

WO 2017/205607 A1

Description

MOVER SYSTEM

Technical Field

[0001] The subject application is directed to a mover system for moving objects and more particularly to a mover system for moving objects having a plurality of independently controlled movers operating along an adjustable predetermined pathway.

Background

[0002] Mover systems for transporting objects to or from a location historically used humans to directly control the movers, such as carts, forklifts, pallet jacks and overhead cranes. Movers, such as overhead cranes, often used to deliver objects to selected areas within an industrial facility have been automated by gantry systems that typically utilize pulling chains in the X and Y directions to control the path of the objects being transported to a desired location. Many times such automation incorporates rotary motors that operate to adjust the pulling chains while an operator uses levels to target deliveries. In the most automated application of a gantry system, a control system, such as a motion coordinate control system, is used in combination with a human machine interface (HMI) to allow an operator to identify an end point, such as a point on a floor map, and the master controller programmatically operates to transport the object to the identified location.

[0003] Assembly systems are often highly automated having programmable control systems, such as PLCs, connected by network cable to a number of servomotors, running chains, conveyers, tracks, mechanical assemblies and the like. The data connections between such components are generally high-speed, time synchronized, deterministic links for obtaining the maximum performance of the

assembly system. Network cable has been preferred over wireless connections because it offers higher data reliability with the least chance of outside interference that can cause a loss of data packets being transmitted across the network. If enough packets are lost in a sequence, an entire assembly operation could fail or error.

[0004] Assembly systems have also been developed that take the form of an oval shaped platform stand where a chain drives a series of movers to transport objects to various end points, such as mounted tool stands, for receiving machining or assembly operations. Such operations typically require a high degree of position accuracy and repeatability. Accordingly, it is common to stop the mover and tightly pin the object being transported to a stable platform, perform the desired operation, unpin the object and start the mover to advance the object to its next end point (location). This operation typically requires movers or objects thereon to be precisely positioned for pinning. In many operations the tooling stands operate independently of the master controller and their operation can be signaled to start by mechanical means such as a switch or a photo eye. Some operations, especially those moving at high speeds, require the various tooling stands to be under the command of a common master controller so their operations are time synchronized to perform a specific tooling function in a unified movement. A problem with many such moving systems, such as chain based systems, is that all the movers and tooling stands must operate at the same line speed. If a problem is encountered the entire operation can be interrupted or stopped.

[0005] Another moving system that has been developed for increasing speed and flexibility of an assembly line operation, includes a master controller connected, such as by a network cable, to a plurality of linear motors arranged generally along

an oval rail system for guiding and commanding multiple magnetic movers. Such systems operate whereby multiple electrical motor wire coils are arranged along the track perpendicularly to the line of travel and with one coil placed next to the next coil to form a linear length of coils. When the coils are powered with varying electrical current a magnetic field is produced which reacts to a magnetic field created by a plate of magnets attached to a mover to cause movement of the mover. By scheduling the amount of current to each linear motor coil in succession, one can control the forward or reverse movement of the mover. The movers each include bearing based wheels and run on a guiding rail system that can be made out of plastic, rubber or metal. A key constraint of such magnet moving systems is the distance between the movers that can run together along the direction of rail due to the mechanical design of the mover length and by the magnetics of the linear motor stage design control ability.

[0006] Another disadvantage with both chain based or magnet moving systems is that the vector path that the movers travel is essentially mechanically fixed for the life of the machine and is not easily reconfigurable without a major redesign of the entire production system. In addition, with respect to magnetic moving systems, the rail system must follow the entire vector looped path, which adds expense to the system. Further, when a bearing begins to wear on one of the movers due to the wheels running along the guiding rail system, there is generally not an easy automated way to remove that mover from a looped configuration without stopping the entire machine for maintenance. For many applications there is also a need for positional accuracy and repeatability requiring independent mover control all the way around the rail system to achieve the maximum product throughput from the system. Because of this need for maximum product throughput,

linear motors must be placed around the entire rail system, including the curves, so that the mover travels at a constant rate. This high rate of speed, particularly around curve sections, increases wear of the support wheels connecting the mover to the rail as well as requiring significant bracing or support of the object to prevent centripetal forces from dislodging or ejecting the object from the mover as it travels along the curve section of the track.

[0007] With the advent of robots, robotic autonomous guided vehicle (AGV) systems have been developed that are configured as forklifts or carts that allow for the safe transportation of objects without the need for operators to directly control them or the need for fixed rail tracks. Such robotic control systems include a human-machine-interface for allowing an operator to input modifications to the robotic operation, such as to direct the robotic mover to pick up and transport objects, such as bulk quantities of raw material, to be delivered to a specified end point (location). The assembly area control system may also be programmed automatically to order shipments via wireless signals when a robotic mover is needed. While such robotic movers can be commanded to run at certain speed, they do not operate under a time scheduled control of a motion plan and do not always follow the same path to go to an assigned end point (destination). Robotic movers of an AGV system are also designed to stop, avoid and steer around humans or other obstacles that occur along their path of travel which changes the time that the mover arrives at an assigned end point. Thus, while the mover may be directed to go to a certain end point (location) there is no specific time goal (scheduled time) as to when it is to arrive. Accordingly, the movers of an AGV system do not operate to speed up automatically if they are behind schedule, often caused because a mover's wheels slip on the warehouse floor or if it had to stop and steel around an obstruction on the way to get to the

designated end point. Thus, there is often a significant difference in time between when a mover arrives at a designated end point and when the mover is scheduled to arrive at the end point.

[0008] The network connection often employed to communicate with an AGV system is standard off-the-shelf secured wireless technology that may already exist in the facility. The connection is designed to use as little network bandwidth as possible. Since an AGV mover has the ability to operate autonomously for some period of time, it is not necessary to be in constant real time communication with the master controller and therefore some data packets being transmitted are lost, not acknowledged and retried over time. Further, the path tracking systems of most AGV systems operate in very coarse increments and are meant to deliver large objects to an end point. Some AGV path tracking systems use navigation devices such as magnets or other markers positioned on the floor to indicate pathways, rooms and no-go zones while other tracking systems are preprogrammed floor map based systems. Most of the preprogrammed floor map based systems require a preexisting floor map of the path space and operate to train the robotic mover where any boundaries lie within the control area. Directional sensors, such as laser or sonar, are used during training to help map additional permanent fixtures that are not on the floor plan (such as desks, partitions, and machinery, etc.). Without such sensors, an AGV mover would often get "lost" during operation because the rotary servo driving the wheels of the mover would not account for errors such as wheel slippage. Typically, an AGV system operates to maintain an approximate location of a mover by comparing what a sensor or set of sensors detect of the walls and/or fixed objects located within the control area to a floor map taking into account the number of rotations of the mover's wheels taken since the last accurate position.

Unfortunately, such path tracking systems are not as effective for large amorphous control areas, such as a warehousing location, where there are not as many fixed unmovable objects to compare against a map. One solution to this problem that has been used is to employ a second sensor or set of sensors that scan certain features, such as ceiling lighting, and adding this information to the AGV's position to map for comparison. However, while this increases the accuracy of the tracking, it also increases the cost of operation and does not provide the needed accuracy for all applications.

[0009] Global position satellite systems (GPS) have been developed and are accurate enough for most outdoor purposes. Unfortunately, GPS signals generally cannot penetrate ceilings and walls making such systems unacceptable for most robotic path tracking systems. Various other systems and methods have also been developed using different sensors and include, for example, the use of a compass to map the magnetic signature of various locations against the floor plan map; using multiple Wi-Fi hub signals strength to a fingerprint of each location against a floor plan map; counting the steps and inferring directions a mover is moving; and using a camera to compare pictures to a map. However, none of these location methods have proven accurate enough by themselves for many applications. Further, while in certain control areas the path tracking systems do operate to provide the needed accuracy in to determine the location of a mover along a path, there is no ability to adjust the path parameters or the path of travel of a mover to ensure that the mover arrives at an end point at a specified or scheduled time.

[0010] For many applications, assembly or manufacturing systems require positioning systems that are reliable and precision accurate (at least .5mm accuracy) at end points. Wireless, GPS and conventional Radio Frequency Identification

(RFID) signal strength triangulation systems have been employed and are relatively inexpensive. However, they often do not provide the required accuracy at critical end points. Visual systems may provide the needed accuracy, they require the sensors to have an unobstructed line of sight which can be relatively difficult to obtain and expensive for use with various equipment layouts in certain applications. Accordingly, they have been used primarily to focus on small areas for synchronizing product transfer between two different pieces of equipment. Magnetic tape or optical scale markers have been used in end points with linear slides and with automated guided vehicles but are often difficult to use along an entire predefined path or to achieve the desired accuracy at speed. Further, free operating movers that stray off the predefined path can get lost and are unable to automatically return to their predefined path. While mover systems operating using a track with linear motors have been developed with a plurality of fixed placed electronic sensors positioned along the track as necessary to get the desired accuracy, this technology can only be read as a mover travels along the fixed predefined path.

[0011] Accordingly, what is needed is a mover system for transporting objects and more particularly to a mover system for transporting objects having a plurality of independently controlled movers operating along an adjustable predefined virtual vector pathway; that allows an operator to easily modify the path of one or more of the movers; that has a system that operates to modify the movement (path parameters and the mover's path of travel) of each mover to ensure that each mover arrives at a predetermined end point (destination) at a predetermined specified or scheduled time; and has the required accuracy for synchronizing the movement (precise location and arrival times at end points) of the movers.

Disclosure of the Invention

[0012] The subject invention is a new and novel mover system for transporting objects from one location to another location such that each mover arrives at a predetermined destination at a scheduled or selected time. In a preferred embodiment of the invention, the mover system is a trackless system whereby independent movers are freely driven while operating under the direction of a master controller. In a preferred embodiment of the invention, each mover operates in forward and reverse velocities and can change directions to transport an object in a simulated assembly closed loop or reciprocating vector path between end points (stations), such as production stations, and then follow a return path back to a start point (queuing area) before arriving at an initial end point, such as an object loading station.

[0013] In a preferred embodiment of the invention each mover is tracked and its position monitored and error controlled by a master controller that transmits control commands that insure the mover arrives at its scheduled time in order to work properly with other tooling and conveyance equipment connected to the system.

[0014] In a preferred embodiment the mover system for transporting objects from one location to another location, such that the objects arrive at selected end points at predetermined scheduled times, the mover system comprises at least one independent mover that follows a predefined virtual vector path and operates under plan parameters, a propulsion system for moving the mover along a path from a start point to at least one end point, a master controller, a communication network in communication with the master controller, tracking sensors that operate to transmit tracking signals to the master controller through the communication network, wherein

the master controller operates to determine a calculated position of the mover and uses the tracking signals to determine the actual position of the mover, and wherein the master controller compares the actual position to a scheduled position and automatically transmits control commands to a mover control system that operates to direct the propulsion system to modify the predefined virtual vector path and/or the plan parameters so that the mover arrives at an end point at the scheduled time.

[0015] In a preferred embodiment of the invention the movement of the mover is adjusted such that the mover arrives at all of the selected end points (destinations) at their scheduled times.

[0016] In a preferred embodiment of the invention the mover control system interacts with the master controller such that a two or three dimensional virtual vector path of the mover is automatically adjusted to increase or decrease the amount of time for a mover to arrive at a selected end point.

[0017] In a preferred embodiment of the invention the mover control system interacts with the master controller such that the plan parameters of a mover is adjusted to increase or decrease the amount of time for a mover to arrive at a selected end point.

[0018] Another preferred embodiment is a mover system for transporting objects from a start point to an end point such that the object arrives at the end point at a scheduled time, the mover system comprising: at least one independent mover having a mover control system that operates to direct the mover to follow a predefined virtual vector path utilizing plan parameters; a propulsion system for receiving mover control commands from the mover control system for moving the mover along a path from the start point to the end point; a master controller; a communication network in communication with the master controller and the mover

control system; wherein the master controller operates to determine a calculated position of the mover and transmits mover control commands to the mover control system to direct the propulsion system to modify the plan parameters and/or the predefined virtual vector path to move the mover so that the calculated position matches a scheduled position for the mover.

[0019] In a preferred embodiment the master controller operates to periodically adjust the plan parameters so that the mover arrives at the end point at the scheduled time.

[0020] In a preferred embodiment the master controller operates such that the mover system is synchronized with the operation of secondary equipment operating in conjunction with the mover system.

[0021] In a preferred embodiment the mover system further comprises a detection system in communication with the mover control system such that if the detection system detects an obstruction, the mover control system operates to automatically create a new defined virtual vector path and transmits mover control commands to the propulsion system to follow the new defined virtual vector path.

[0022] In a preferred embodiment the mover control system operates to automatically create new plan parameters along the new defined virtual vector path so that the mover arrives at the end point at its scheduled time.

[0023] In a preferred embodiment the mover system further comprises a path tracking system that operates to identify specific locations along the predefined virtual vector path.

[0024] In a preferred embodiment the path tracking system comprises one or more navigation devices that operate to provide information to the mover control system which operates to calculate the actual position of the mover and further

operates to compare the actual position with a scheduled position and further operates to modify or create a new predefined virtual vector path and/or to modify the plan parameters so that the mover travels such that the actual position will continuously match the scheduled position and arrives at the end point at the scheduled time.

[0025] In a preferred embodiment the path tracking system comprises navigation devices in the form of magnetic or inductive markers that operate to provide location information to the mover control system when detected by tracking sensors positioned on the mover and wherein the tracking sensors are angled magnetoresistive or inductive sensors positioned in a pattern on the mover and operate to provide the mover control system with direction of travel of the mover.

[0026] In a preferred embodiment the path tracking system comprises navigation devices in the form of radio frequency identification tags positioned within a control area and operate to transmit absolute location coordinates to the mover control system.

[0027] In a preferred embodiment each independent mover comprises a pair of coaxially aligned wheels and at least one steering wheel and a cover having a bumper assembly and an indented section configured to mate with a bumper assembly of another mover to minimize pitch between movers.

[0028] In a preferred embodiment of the invention the mover system comprises a propulsion system that operates in a forward and reverse directions and to change the plan parameters of the mover such that the mover operates in a control area defined by coordinate space in at least two-dimensions such that the mover follows a predefined virtual vector path that returns to its start point and such

that the mover's motion is time scheduled and error corrected by commands from the master controller to the mover control system.

[0029] In another preferred embodiment of the invention the mover system comprises a track and whereby a mover travels along the track using magnetic levitation and propulsion.

[0030] In a preferred embodiment of the invention the mover system comprises a plurality of electromagnetic propulsion coils arranged to permit the mover to travel in two dimensions.

[0031] In a preferred embodiment of the invention the mover system comprises a plurality of electromagnetic propulsion coils to permit movers to travel in three dimensions.

[0032] In a preferred embodiment of the invention the mover system includes a communication system for communicating commands and information to and from the master controller to the mover control system, wherein the communication system uses multiple wireless frequencies bands to communicate for control and feedback in areas where high amounts of radio transmission interference (RTI) is present.

[0033] In a preferred embodiment the communication system uses wireless communication for communicating with the mover such that commands are repeated using one or more wireless frequency bands to insure that communication packets are received by the mover control system in heavy RTI environments.

[0034] In another preferred embodiment of the invention the communication system comprises multiple antennas positions around the physical platform space for receiving a location signal being generated by the mover control system and whereby the master controller operates to measure the strength of the location signal

and uses triangulation to determine the position of the mover in the global coordinate system.

[0035] In another preferred embodiment of the invention the communication system uses one or more visual cameras that operate with the mover control system to identify key parts of the control area and transmit information to the master controller that operates to determine the actual position of the mover in the coordinate system.

[0036] In another preferred embodiment of the invention the communication system uses markers mounted with the control area and one or more sensors positioned on the mover that cooperate to transmit information to the master controller which operates to determine the actual position (global coordinates) of the mover.

[0037] In another preferred embodiment of the invention the communication system comprises a sensor mounted to an external device that operates to detect when a mover travels past the device and transmits information to the master controller.

[0038] In a preferred embodiment of the invention the mover system further comprises a mechanical system for securing the position of the mover and/or an object being transported by the mover during a mechanical operation being performed on the object.

[0039] In a preferred embodiment of the invention the mechanical system for securing the position of the mover and/or the object uses a pinning system to lock the location of a stopped mover in a fixed location.

[0040] In a preferred embodiment of the invention the mechanical system for securing the position of the mover comprises a guiding rail placed along a track effective for providing addition mover stability.

[0041] In a preferred embodiment of the invention the master controller operates to vary the plan parameters of a mover as it travels along the predefined virtual path to synchronize the mover with secondary equipment (one or more external operational devices).

[0042] In a preferred embodiment of the invention the master controller operates to vary the plan parameters or the path of travel of the mover to reposition and resynchronize the mover in relation to other movers traveling along the same predefined virtual path.

[0043] In a preferred embodiment of the invention the master controller includes a human-machine interface that operates to communicate the removal or additional one or more movers of the mover system and whereby the master controller operates to adjust the plan parameters of the additional other movers to adjust for the increase or decrease of movers traveling along the path.

[0044] In a preferred embodiment of the invention the mover includes a battery and an electric mover charging device that cooperates with an external charging device such that when the electric mover charging device is in close proximately with the external charging device they charge the battery on the mover.

[0045] In a preferred embodiment of the invention the mover system further comprises electromagnetic levitation coils, propulsion coils and levitation magnets and propulsion magnets mounted to the mover to produce magnetic levitation and motion along a track.

[0046] In a preferred embodiment of the invention the electromagnetic levitation coils rotate so the angle of direction of movement of the mover can be changed.

[0047] In a preferred embodiment of the invention the master controller calculates the amount of speed or path correction needed to ensure a mover arrives at a location at a predetermined time (scheduled time) and compares it to a reference and uses the comparison to determine the probability that one or more of the wearable parts on the mover needs replacement.

[0048] In a preferred embodiment of the invention each mover includes an cover or an encasement for electronics, connectors, and any non-critical parts to the operation of the mover that is suitable for washing or spraying with water or other soap based clearing agents.

[0049] In a preferred embodiment of the invention the human-machine interface operates such that users can input into the master controller a representation of the virtual path that each mover will follow and whereby the master controller operates to translate the representation into executable motion control commands for transmitting to each mover control system.

[0050] In another preferred embodiment of the invention the human-machine interface operates to allow an update or modification to an existing virtual path for one or more movers and whereby the master controller operates to translate that updated representation into executable motion control commands for transmitting to each mover control system.

[0051] A preferred embodiment of the moving system of the subject invention comprises a master controller for monitoring and controlling a master operation comprising one or more individual movers such that each mover arrives at

predefined end point at selected times (scheduled times). Each mover includes a mover control system that interacts with the master controller and has a predefined virtual path with one or more defined end points. The predefined virtual path comprises a plurality of discrete points, wherein each discrete point has a vector axis for use by the master controller and the mover control system to direct the mover to move such that it arrives at each defined end point at a selected time. In operation, the master controller functions to modify the predefined virtual path and sends commands to the mover control system in response to changes in the master operations.

[0052] In another preferred embodiment of the invention the master control system operates such that standard movement commands from the master controller is converted into new two or three dimensional virtual path.

[0053] Various other objects, advantages, and embodiments of the invention will be apparent from the following description, the accompanying drawings, and the appended claims.

Brief Description of the Drawings

[0054] To provide a more complete understanding of the present invention and further features and advantages thereof, reference is now made to the following description taken in conjunction with the accompanying drawings, in which:

[0055] **FIG. 1** a schematic representation of a preferred embodiment of a mover system of the subject invention comprising one or more movers each having a propulsion system, a mover control system and a path tracking system in communication with a master controller by a communications network;

[0056] FIG. 2 is a schematic representation of the control area having the mover system of FIG. 1 illustrating one or more movers traveling along a path having a start point, one or more end points, and one or more alternative paths;

[0057] FIG. 3 is a schematic representation of a mover following a predefined virtual path showing the calculated position of the mover and the actual position of the mover, its calculated position and its actual path of travel;

[0058] FIG. 4 is a schematic representation showing the master controller in communication with secondary equipment and human-machine interface and a mover for receiving an object;

[0059] FIG. 5 is a schematic representation of the detection system showing an obstruction having a transmitter thereon and a detection sensor on the mover and a threshold distance around the obstruction;

[0060] FIG. 6 is a schematic representation showing the mover control system of a mover sending mover control commands to the propulsion system;

[0061] FIG. 7 is a schematic representation showing the mover control system showing a predefined virtual vector path for a mover to travel to an end point of an alternate defined virtual vector path for a mover to travel to the same end point;

[0062] FIG. 8 is a schematic representation showing the path tracking system having navigation devices and tracking sensors in communication with the mover control system;

[0063] FIG. 9 is a schematic representation showing a mover having a mover control system and rotational tracking sensors for tracking the number of rotations of a wheel attached to the mover and used to calculate the position of the mover in relation to the mover's predefined virtual path;

[0064] FIG. 10 is a schematic representation of a mover having path tracking system with navigation devices that are detected by tracking sensors for transmitting information to the mover control system and further comprising supplemental sensors;

[0065] FIG. 11 is a schematic representation showing a mover having a path tracking system having one or more navigation devices with absolute location coordinates and a mover having tracking sensors for detecting the one or more navigation devices;

[0066] FIG. 12 is a schematic representation illustrating a navigation device having an identification tag that operates to send tracking signals that can be received by the tracking sensors on a mover;

[0067] FIG. 13 is a schematic representation of a mover having an undercarriage and one or more tracking sensors positioned thereon;

[0068] FIG. 14 is a schematic representation of a preferred embodiment of a pair of movers each comprising a pair of coaxially aligned wheels, at least one steering wheel, and a propulsion system having a battery that operates to energize one or more electric propulsion motors for driving coaxially aligned wheels;

[0069] FIG. 15 is a schematic representation of a side view of a mover having a palette section for supporting an object and an object transfer mechanism for transferring the object from/onto the palette section to/from an object receiving platform for loading and/or unloading one or more objects at an end point;

[0070] FIG. 16 is a schematic representation of another preferred embodiment of the invention showing a track having one or more curved sections and one or more curved sections;

[0071] FIG. 17 is a schematic representation of another preferred embodiment of a mover system of the subject invention showing a track having a bottom wall, parallel side walls, and a propulsion system having electromagnetic levitation coils for levitating a mover and a plurality of electromagnetic propulsion coils for moving a mover along its predefined virtual path (track);

[0072] FIG. 18 is a schematic representation showing another preferred embodiment of the invention showing a portion of the track having banking;

[0073] FIG. 19 is a schematic representation of another preferred embodiment of the mover system showing the propulsion system having a plurality of propulsion coils and/or levitation coils arranged along the bottom wall of the track that operate to impart x and y movement of the mover;

[0074] FIG. 20 is a schematic representation of another preferred embodiment of the mover system showing the propulsion system having a plurality of propulsion coils and/or levitation coils arranged along the side walls of the track that operate to impart x and z movement of the mover;

[0075] FIG. 21 is a schematic representation of another preferred embodiment of the mover system of the subject invention showing a track having a plurality of swiveling wheels each mounted to a pair of rotary servomotors that cooperate together to create a conveyor for supporting a mover and for moving a mover in both the x and y directions;

[0076] FIG. 22 is a schematic representation of another preferred embodiment of the invention showing a mover having an object thereon at a scheduled end point having secondary equipment and a mechanical system for securing the position of the mover and/or an object when it arrives at an end point;

[0077] FIG. 23 is a schematic representation of another preferred embodiment of the invention showing a mover positioning apparatus, such as guides, for guiding a mover into precise position at an end point;

[0078] FIG. 24 is a flow diagram illustrating the communication network and the control systems of the subject invention for directing a mover along a predefined virtual path and for amending the path and/or the plan parameters of the mover for directing a mover to an end point at a scheduled time.

Best Mode for Carrying Out the Invention

[0079] The subject invention is a new and novel mover system for transporting objects from one location to another location such that each mover arrives at a selected destination at a predetermined scheduled time. In a preferred embodiment of the invention, the mover system is a trackless system whereby independent movers are freely driven along a predefined virtual vector path operating under the direction of a main controller that provides control commands having x and y components. In a preferred embodiment of the invention, each mover operates in forward and reverse velocities and can change directions to transport an object in a simulated assembly closed loop or reciprocating vector path between end points, such as production stations and/or loading and unloading stations, and then follow a return path back to a queuing area before arriving at an initial start point.

[0080] As used herein a platform is an x and y coordinate surface that a mover travels along having a vertical z axis. The terms "up" or "upper" refers to the z direction away from the platform (path surface) and the term "down" or "downwardly" refers to the z direction towards the platform (path surface).

[0081] In a preferred embodiment of the invention, a master controller uses a one dimensional virtual rotary axis data structure (which unlike master controllers

used to operate rotary servo drives through the control of one dimensional axis data objects) for operating independently control movers traveling along a predefined path. Motion plan parameters (such as mover speed, acceleration, direction or travel) for points along the path of travel are captured and transferred electronically over a communications network to a traffic control system of the master controller. The length setting in the virtual axis data structure is the length of the predefined virtual defined path (virtual vector path loop) that one or more movers follow. Feedback, status and error information is received and calculated by the traffic control system and stored in tags in a memory bank of the master controller which can be used programmatically and/or displayed on a human-machine interface (HMI). Preferably, the HMI operates such that users can input into the master controller a representation of the virtual vector path that each mover will follow and the master controller then operates to translate the representation into executable motion control commands for transmitting to each mover's control system. It should be understood that the predefined virtual vector path comprises a plurality of discrete points wherein each discrete point has a vector axis for use by the master controller in directing a mover such that it follows the predefined virtual path and arrives at an end point at a selected time. The master controller further operates to continuously or periodically monitor individual movers and if it determines that a mover will arrive at an end point ahead of or behind its scheduled time, the master controller operates to adjust the virtual vector path to create a new virtual vector path and/or adjust the path parameters along one or more discrete points such that a mover arrives at its predefined end point at the scheduled time.

Mover System

[0082] Referring to **FIGs. 1, 2 and 3**, schematic exemplary illustrations of a mover system for transporting objects **100** is shown having a master controller **102**, one or more movers **104** each having a propulsion system **106** for propelling the mover **104** along a path **108**, a path tracking system **110** and a mover control system **112** both in communication with the master controller **102** through a communication network **114**. A predefined virtual vector path **116** for each mover **104** is programmed by the master controller **102** for directing the mover **104** to travel from a start point **118** to one or more end points **120** within a control area **122**. It should be understood that as used herein the term "start point" is the point at which a mover begins to travel along the predefined virtual vector path **116**. Such a "start point" can also be the "end point" of another defined path. An "end point" as used herein is a predefined destination, location, or station (such as a loading or unloading station, a holding area, battery recharging area, repair area, or a manufacturing or machining station) that a mover is to travel to and preferably receive an object and/or deliver an object and/or to place an object in position for receiving an operation, such as a machining operation, or for repair and maintenance. Preferably, the control area **122** is defined for a mover system **100** and can include one or more actual paths of travel **108** that a mover **104** takes while following its predefined virtual vector path **116**. It should be understood that the predefined virtual vector path **116** is the path that a mover is programmed to follow and the actual path of travel **108** is the path that the mover actually takes while traveling from the start point **118** to the various end points **120** and back to the start point **118**. It should also be understood as described below that the predefined virtual vector path **116** may be the same or different than the actual path of travel **108**. Further, it should also be understood that the predefined virtual vector path **116** is preferably a closed loop path or a closed loop

path having one or more side paths **124** and may be identical to the paths being traveled by one or more other movers or may be a path unique for a particular mover.

Path Planning

[0083] The master controller **102** is preferably a standard industrial programmable logic controller (PLC) such as those typically used for operating a rotary servo drives through the control of one dimensional axis data objects. Conventionally, an axis data object specifies the length of the circumference of the rotary servo driven wheel, chain, belt or other end effector. The axis data object usually also has dynamic limits for a motion parameter, such as speed, acceleration, jerk etc. Motion commands **126 (FIG. 4)**, such as to travel from one end point to another end point or to rotate at a certain speed, are performed using software programmatically on the axis data object. Often, all of the equipment in an assembly area are operated by a single master controller and are slaved to a master physical or virtual axis' control. The slaving process permits the entire assembly process to speed up or slow down by simply adjusting the speed of the master axis. In a preferred embodiment of the invention, the master controller **102** uses a one dimensional virtual rotary axis data structure. The predefined virtual vector path **116**, together with the plan parameters **128** (such as speed, acceleration and deceleration, time, and other operational parameters) for a mover **104** traveling along the predefined virtual vector path **116** are programmatically inputted, such as by use of the human-machine-interface **130**, into the traffic control system **132 (FIG. 4)** of the master controller **102**. It should be understood that in the subject invention the length setting in the virtual axis data structure is the length of the predefined virtual path to be followed by a mover and the dynamic velocity limit is the maximum

speed that a mover can travel. It should also be understood that in a predefined embodiment the master controller **102** operates such that secondary equipment **10** (such as loading, unloading, packaging, assembly and machining equipment) operating in conjunction with the mover system functions under a physical or virtual axis control which is synchronized with the operations of the master controller **102** directing the mover system **100**. Accordingly, in operation when the master controller speeds up or slows down the master axis of an operation (such as an assembly, manufacturing, packaging, transportation operations and the like) the mover system **100** operating in conjunction with the operation can operate to automatically speed up or slow down accordingly.

[0084] In another preferred embodiment of the invention the master controller operates as a motion coordinate control system capable of issuing two-dimensional commands directly, such as motion coordinate control systems using x and y dimensions of mechanical gantry or H-Bot systems. In a preferred embodiment, the coordinate system utilized is the global coordinates of the control area or along the platform and paired sets of x and y virtual axis or similar data structures are assigned to each mover. The intersection of the x and y data structure's position setting is considered the object (mover) mechanical "end point." A combination straight and curved motion commands are then programmatically transmitted to the mover control system using the communication network for directing a mover using the coordinate system to follow a predefined virtual vector path. It should be understood that a predefined virtual vector path can be a path loop programmed without the need for external path planning software. It should also be understood that the preferred embodiment permits master controller to direct a mover to deviate from the predefined virtual vector path to an alternate virtual vector path such as to perform a

specific purpose such as an alternate operation or for servicing (maintenance) of the mover.

[0085] In another preferred embodiment of the invention, the master controller is a robotic type controller system that point streams two-dimensional Cartesian commands to an apparatus, device or system, such as used to control industrial robots. The master controller operates to periodically download a series of x and y position commands to the mover control system for each mover as to where it should be (predefined scheduled position) at a specified time (scheduled time). The x and y positions are in a statically stored data array and are spaced positions on the predefined virtual vector path that the mover is to follow. In another preferred embodiment, the master controller operates to include trajectory information for the path and plan parameters (i.e. velocity) that the mover should follow between commanded position points (discrete points along the predefined virtual vector path). It should be understood that the use of such position points permits a mover to be monitored and controlled to operate within tight position accuracy, preferable less than 5mm. If no trajectory information is issued, the mover control system operates to match the vector angle of the transition between these position points and commands a plan parameters (i.e. speed) that matches the required time interval to travel between such points. In a preferred embodiment, the plan parameters and trajectory information are provided so that a mover moves without abrupt changes in its direction of travel or with regard to a plan parameter. For example, in changing direction, the mover can follow a clothoid or approximate clothoid arc to minimize any abrupt variation in curvature that can cause variation in centripetal force acting on the mover. In another preferred embodiment a mover operates along a predefined platform having curve portions in the form of clothoid arcs, which can be

banked to reduce wheel slippage and/or to reduce the effects of centripetal force acting on the mover. It should now be apparent to one skilled in the art that the preferred amount of banking (bank angle) can be easily calculated and is contingent on the surface features of the platform, and the acceleration, weight and dimensions of the mover traveling along the path.

[0086] In another preferred embodiment, conventional path planning software is used to create a standard virtual path loop, such as used on a controller system with a one dimensional vector rotary axis to be slaved to a master axis which can be time synchronized with other equipment. A motion coordinate system, as described above is utilized by the master controller that sends control commands to the mover control system that operates to direct the propulsion system to deviate off the predefined virtual vector path such as when a mover requires maintenance. In a preferred embodiment, the master controller can also operate to direct a replacement mover by sending commands to the mover control system of another mover which operates to direct the mover to follow the predefined virtual vector path of the replaced mover while the mover to be replaced is directed along a side path to an alternative end point, such as a maintenance or repair station. It should be understood that the path and plan parameters of the mover preferably are adjusted, automatically or by use of a HMI, so that the replacement mover arrives at the scheduled end point(s) at the scheduled time. In this way, movers can be taken in and out of the moving system without interfering or hindering the operation of the mover system as well as any secondary operations.

[0087] It should be understood that the master controller operates as if it is commanding individual, non-related movers each operating along its own path. Accordingly, from the master controller perspective, it operates as if it is controlling

separate movers running on paths within separate control areas with no chance of movers colliding. For an exemplary illustration, if the moving system is configured to run with six movers, the master controller operates as if there were six separate paths or platforms with one mover each. To avoid collision and make sure that no movers are commanded to occupy the same space at the same time programmatically. This is done by the traffic control system of the master controller that operates to overlay the predefined virtual vector paths of the movers and comparing commanded positions and times. It should also be understood that detecting systems can also be incorporated that operate to ensure that no two movers are in danger of colliding with each other by comparing their actual positions together with their predefined virtual vector paths.

[0088] In operation, the master controller **102** operates to synchronize the independently controlled movers **104** with the timing needs of the various end points (stations) **120** (such as tooling, machining and/or product conveyance equipment) under its control. In a preferred embodiment, the master controller **102** functions to synchronize the movements of the movers **104** with a common master timer **134** utilized throughout all the secondary equipment **10** within the control area **122** and can be incorporated into the master controller **102** or can be an independent timer or a timer within another device within the control area **122**.

[0089] In a preferred embodiment, as illustrated in **FIGs. 2 and 4**, the master controller **102** operates to select a mover **104** that is to arrive at an end point (station) **120**, to receive or deposit an object **12**. In a preferred embodiment, secondary equipment **10**, such as a conveyor, belt, wheel or robot operating in conjunction with the mover system **100** can signal via photo eye, switch or other method to the master controller **102** that an object **12** is coming to the selected end

point **120** (pick-up station). The master controller **102** operates to send motion commands **126** through the communication network **114** to the mover control system **112** of a selected mover **104** to direct the mover **104** to travel from its current position (such as from a queuing area) to the selected end point **120** (such as a loading station). The motion commands **126** transmitted to the mover control system **112** are in the form of speed commands and/or directional commands to direct the mover to follow a predefined virtual vector path **116** utilizing plan parameters **128** (speed, velocity, acceleration) such that the mover **104** is synchronized with its arrival at the selected end point **120** (loading station) that matches the arrival of the object(s) **12** at the end point **120** (loading station). Accordingly, the master physical or virtual axis of an industrial operation (secondary equipment) is synchronized with the mover system. In another preferred embodiment of the invention, the master controller **102** can further transmit motion commands **126** to the mover control system **112** causing the mover **102** to stop and wait for the object **12** to arrive or to direct the mover **104** to one or more mover pick-up stations (end points **120**) in order to pick-up multiple objects. It should be understood that if objects are arriving in a non-uniform spaced manner, for example an operation whereby movers are placed under fixed filling nozzles or being shrink wrapped together for eventual boxing, the master controller **102** operates to issue motion commands **126** for individual movers **104** that varies their plan parameters **128** after they leave an end point **120** (product loading station) to create uniform spacing (pitch) between the movers **104** before they arrive at the next end point **120** (station). In another preferred embodiment, the master controller **102** operates to transmit motion commands **126** to a mover's control system **112** to synchronize the speed of the mover **104** as it passes by an end point **120** (such as a tooling station, for a specific operation, such as to match

the speed needed for a print head printing a serial number on the object). In another preferred embodiment the master controller **102** can further operate to transmit motion commands **126** to a group of movers **104** traveling closely together to modify their plan parameters **128**, such as to accelerate to an end point **120** (such as a product unloading station) to arrive at the scheduled time so an object **12** can be placed in a carton or box as a group. The movers **104** are synchronized by the master controller **102** to be moved out of the way on the end point **120** in time for the next group of objects to arrive at the end point **120** (unload station) and picked up by another mover or movers.

Detection System

[0090] Referring to **FIGs. 1, 2, 3 and 5**, in a preferred embodiment of the invention the control area **122** is a dedicated area, such as a closed-loop track, for operating one or more movers **104**. The actual path of travel **108** within the control area **122** preferably include various detection systems **136** that cooperate with the path tracking systems **110** on each mover **104** to ensure that a mover **104** does not contact (collide) with an obstruction or another mover. It should be understood that the obstruction **14** may be a fixed object or temporary obstruction that was placed at a location after the predefined virtual vector path **116** was programmed into the master controller **102** or is an object positioned temporary at a location (such as a person, a disabled mover, package, or other type of object) that obstructs an approaching mover traveling along its predefined virtual vector path **116**. In a preferred embodiment as illustrated in **FIG. 5**, the detection system **136** includes a transmitter **138** positioned on the obstruction **14** such that if detected by a detection sensor **140** of the path tracking system **110** on a mover **104** as it follows its predefined virtual vector path **116**, it causes the mover control system **112** or the

master controller **102** to automatically calculate and determine if the mover's predefined virtual vector path **116** will result in the mover traveling within a particular threshold distance **16** from the obstruction **14**. If the distance is below the set threshold, the mover control system **112** operates to send mover control commands **142** to the propulsion system **106** (**FIG. 6**) and the predefined virtual vector path **116** is amended creating a new or alternate defined virtual vector path **144** (**FIG. 7**) or to an alternative side path **124** (**FIG. 2**) to ensure that the mover **104** does not intersect and collide with the obstruction **14**. Accordingly, it should now be apparent that the detection system cooperates with the mover control system such that if the detection system detects an obstruction the mover control system automatically operates to create a new or modified defined virtual vector path and transmits mover control commands to the propulsion system so that it operates to move the mover such that it follows the new or modified defined virtual vector path. Further, the mover control system operates to create plan parameters along the new defined or modified virtual vector path so that the mover arrives at the end point(s) at the scheduled time.

[0091] In a preferred embodiment of the invention the traffic control system **132** operates to ensure that the mover's movement along the predefined virtual vector path **116** does not result in the mover **104** contacting (colliding) with an obstruction **14** or another mover by using the mover's predefined virtual vector path **116** and the mover's actual position **146** (**FIG. 3**) and if the traffic control system **132** determines that contact is possible or is within a set threshold distance **16**, it further operates (such as by using of standard proportional, integral, derivative (PID) closed loop theory) to determine adjustments or corrections to the plan parameters **128** (such as but not limited to changes to the mover's velocity, acceleration, and/or path) necessary to avoid contact with an obstruction **14** or other mover and return to the

mover's predefined virtual vector path **116** (or to begin traveling along a new, alternate or modified virtual path). The master controller **102** then transmits motion commands **126** to the mover control system **112** for directing the propulsion system **106** to implement the calculated changes in the plan parameters **128**. In another preferred embodiment, the mover control system **112** operates independently to direct the propulsion system **106** to calculate and implement the calculated changes in the plan parameters **128**. It should be understood that in a preferred embodiment, the master controller or the mover control system operates such that changes in the plan parameters permits a mover to adjust or change its path of travel while arriving at each end point at the scheduled times.

Communication Network

[0092] The communication network **114** preferably is a wireless communication network that uses one or more frequency bands for communication between the master controller **102** and the individual mover control systems **112** and between the master controller **102** and the human-machine-interface (HMI) **130**. Preferably, the master controller **102** and the mover control systems **112** operate to redundantly repeat sending communication packets using the same frequency band as well as sending duplicate communication packets over multiple frequency bands in the event of possible interference, such as from radio or television interference. For a non-limiting illustration, by using multiple wireless bands, such as Wifi in cooperation with Bluetooth, provides redundancy and minimizes the likelihood of communication interruption. Accordingly, using such multiple communication redundancies over the wireless communication network **114** operates to achieve improved reliability of real time connections with the movers **104** necessary for the mover's position and motion to be time synchronized.

Tracking System

[0093] In a preferred embodiment, as illustrated in **FIGs. 8** and **9**, the path tracking system **110** includes navigation devices **154**, such as path markings, positioned within the control area **122**, such as along the predefined virtual vector paths **116**, and are programmed in the mover system **100** and operate to identify specific locations or to guide a mover **104** along the predefined virtual vector path **116**. In other preferred embodiments, the navigation devices **154** comprise magnetic, electronic, audio frequency or radio frequency or optical markers or devices (or a combination thereof) that are detected by one or more tracking sensors **148** on a mover **104**. Preferably the path tracking system **110** operates using a two dimensional Cartesian global coordinate system with the Cartesian global coordinate (0, 0) as the start point **118**. To track a mover's position within the control area **122** (global coordinate space), one or more path tracking systems **110** can be utilized. For a non-limiting exemplary illustration as shown in **FIG. 9**, the mover control system **112** receives tracking signals **150** from one or more conventional rotational tracking sensors or encoders **148**, such as an optical rotary encoder, that provides outputs (counts) that correspond to or indicates each rotation (angular displacement) of a wheel **152** connected to the mover **104** and riding along the platform of the actual path of travel **108** (**FIG. 2**). The mover control system **112** using the tracking signals **150** for each rotation of the wheel **152** together with the circumference of the wheel operates to determine the calculated position **156** (x, y coordinates) of the mover **104** along the predefined virtual vector path **116**. In order to compensate or correct for errors, such as errors due to wheel slippage, in a preferred embodiment, as illustrated in **FIG. 10**, the path tracking system **110** includes a navigation device **154**, such as a positional encoding scale and registration marker positioned

throughout the control area 122. In operation, tracking sensors 148 on a mover 104 detects the navigation devices 154 and transmits the information to the mover control system 112 which causes the mover control system 112 to determine the mover's actual position 146 and compares the mover's actual position 146 with its calculated position 156 (based on the predefined virtual vector path 116 and the time and estimated speed of travel) (FIG. 3) and operates to adjust the calculated position 156 to correspond to the actual position 146. It should be understood that if the difference between the calculated position and the actual position is outside an acceptable error tolerance, in a preferred embodiment of the invention the master controller operates to direct the mover to an alternate end point, such as a maintenance station, or to transmit a notice to be displayed on the HMI, and to direct an alternate mover to replace the mover needing maintenance. It should also be understood that the navigation devices 154 used with the path tracking system 110 can be in the form of various types of markers including visual markers, magnetic markers, electronic markers, physical markers, and such markers detectable by the mover's tracking sensors 148. In another preferred embodiment of the invention, the mover control system 112 further operates to compare the actual position 146 to the predefined virtual vector path 116 of the mover 104 and sends control commands 142 (FIGs. 3 and 6) that causes the propulsion system 106 of the mover 104 (or the replacement mover) to adjust the plan parameters 128 (such as to speed up or slow down) of the mover 104 until the mover's actual position 146 aligns with its predefined scheduled position 158 (based on a specific time) along its predefined virtual vector path 116. It should also be understood that the plan parameters 128 and/or the predefined virtual vector path 116 can be adjusted or amended to ensure that the mover arrives at each end point 120 at the scheduled time 159. It should be

understood that by continually monitoring the mover's actual position and its predefined scheduled position and adjusting the mover's plan parameters and/or its predefined virtual vector path permits the mover to arrive in a precise position at its end point (within 5mm and depending on the need for accuracy within .5mm) at its scheduled time.

[0094] In another preferred embodiment of the invention, as shown in **FIG. 10**, the path tracking system **110** is a global position system. Navigation devices **154**, such as visual stickers attached to a mover **104**, operate such that tracking sensors **148** (or readers), in the form of electronic cameras, communicates with the traffic control system (HTC) **132** of the master controller **102** to identify the mover and the actual position **146** of the mover **104**. Another preferred embodiment of the invention, the path tracking system **110** utilizes wireless single strength triangulation such that in operation, a transmitter **160** of the path tracking system **110** mounted to a mover **104** transmits tracking signals **150** along one or more wireless frequency bands and the relative strength of the signals **150** are used to triangulate the mover's actual position **146** within the control area **122**. The master controller **102** then operates to determine the actual position **146** of a mover **104** and by comparing or overlapping the mover's actual position **146** with its scheduled position **158** (**FIG. 3**) along the predefined virtual vector path **116** operates to transmit motion commands **126** to the mover control system **112** directing the propulsion system **106** to change its plan parameters **128** (such as speed or direction of movement) of the mover **104** to ensure that the mover **104** returns to its predetermined scheduled position **158** and continues to follow its predefined virtual vector path **116** (**FIG. 9**).

[0095] In another preferred embodiment of the path tracking system **110**, the navigation devices **154** are in the form of radio frequency identification (RFID) tags

(active or passive) positioned within the control area **122**. Each navigation device **154** includes its absolute location coordinates **157** that operate to provide location information to a mover **104** that comes within range to be detected by tracking sensors or readers (antenna) **148** positioned along the undercarriage **162** of the mover **104** (**FIG. 13**). In operation, as a mover travels near (preferably over) a navigation device **154**, the tracking sensors or readers **148** operate to receive the RFID transmission and communicates the RFID location information (coordinates) to the mover control system **112**. Preferably, the mover control system **112** transmits the location information in real time through the communication network **114** to the master controller **102**.

[0096] In another preferred embodiment the navigation devices **154** are positioned within the control area **122** and are in the form of magnetic or inductive markers with a unique identification tag, such as by a RFID tag, that includes the identifier's absolute location coordinates **157** that operate to provide location information to a mover **104** that comes within range and is detected by tracking sensors or readers (antenna) **148** positioned along the undercarriage **162** of the mover **104**. Preferably, the tracking sensors **148** are angled magnetoresistive or inductive sensors positioned in a rectangular pattern that operate to indicate the general direction of travel of the mover **104** as well as determining the actual position **146** of the mover **104**. For a non-limiting illustration, when a mover traveling along its path moves over a navigation device such that the navigation device is below and preferably between two or more of the tracking sensors positioned along the undercarriage of the mover, together with the identification tag information of the device, permits the mover control system in cooperation with the master controller to accurately determine the actual position (absolute location coordinates) of the

mover. It has been surprising found that such a path tracking system permits accurate determination (within 5 mm or less) of the actual position (absolute location coordinates) of the mover at the location of the navigation device. It should be understood that the pattern of the tracking sensors along the undercarriage of the mover permits the determination as to the general direction the navigation device with respect to the mover when in range of the tracking sensors, even when the navigation device is not under the mover. When the mover moves to a location directly above the navigation device so that the device is positioned between two tracking sensors, the mover's incremental measurements can be determined and an accurate position determination (less than about .5mm) can be made and used to adjust the calculated position of the mover to be adjusted thereby correcting for drift by a wheel encoder (tracking sensor) or adjustments to the path followed by the mover. In another preferred embodiment of the invention, as illustrated in FIG. 12, each navigation device **154** includes a unique identification tag **155** that provides absolute identification of the particular device. Preferably, the identification tag **155** is transmitted as part of an RFID transmission (tracking signals **150**) but it should be understood that the identification can be in the form of a visual or other perceived form. By positioning navigation devices at predetermined sensor range distances, the mover's position relative to the device within the sensor range can be determined. The mover control system **112** can then operate to direct the mover's propulsion system **106** to move the mover **104** such that at least two of the tracking sensors **148** are above and between the navigation device **154** providing a precise and accurate actual position **146** of the mover **104**. It should be understood that when an navigation device is placed in the control area its global position coordinates are entered into the master controller, such as by use of the HMI, and is

used as part of the predefined virtual vector path planning for the movers operating in the mover system. It should further be understood that by placing a sufficient number of navigation devices within the control area or platform, the master controller can periodically compare a mover's calculated position and/or scheduled position with its actual position thereby correcting any inaccuracy in the calculated position (such as caused by errors in the incremental wheel encoder or wheel slippage) as well as adjusting the mover's path parameters and/or predefined virtual path to ensure that the mover's actual position is synchronize with the mover's scheduled position. It has been found that position that by using the described path tracking system accuracy of less than about .5mm can be achieved.

[0097] In another preferred embodiment, to further improve the position accuracy of a mover, the path tracking system includes supplemental tracking sensors **164**, such as gyroscopic and/or accelerometer sensors. In operation, the supplemental tracking sensors **164** (such as a gyroscopic sensor) operate to track the general direction of a mover **104** and the mover control system **112** operates to compare the general direction of the mover **104** with direction information obtained from other tracking sensors **148** (such as from wheel encoders) to provide an estimation as to wheel slippage. In another preferred embodiment, the supplemental tracking sensors **164** (such as an accelerometer sensor) operate to determine acceleration of the mover. For a non-limiting exemplary illustration, if a mover was traveling at a constant velocity and contacts an oily spot on the platform such that wheel on the mover begins to slip, the tracking sensor, such as a wheel encoder, may inaccurately record an increase in the mover's velocity due to less surface resistance on the wheels. However, the secondary tracking sensor would indicate a

sudden deceleration which would be used by the mover control system and the master controller to correct the information from the tracking sensor (encoder).

[0098] It should now be apparent that the path tracking system of the mover system operates to identify specific locations along the predefined virtual vector path. Preferably, the path tracking system has one or more navigation devices that operate to provide information to the mover control system for use in calculating the actual position of the mover. The mover control system (or the master controller) further operates to compare the calculated position with the actual position and to correct the calculated position so that it matches the actual position of the mover. It should be understood that if the difference between the calculated position and the actual position is outside a predefined tolerance, the master controller transmits a notice to the HMI that the mover may be experiencing electrical or mechanical errors. It should also be understood that the mover control system (or the master controller) further operates to compare the actual position with the scheduled position and if the difference is outside a predefined tolerance, the master controller transmits a notice to the HMI that the mover may be in need of maintenance. Further, in a preferred embodiment the mover control system operates to modify the predefined virtual vector path or create a new predefined virtual vector path or operates to adjust the plan parameters so that the mover arrives at the end point(s) at its scheduled time.

Propulsion Systems

[0099] In a preferred embodiment of the invention, as illustrated in **FIGs. 14** and **15**, the movers **104** comprise a pair of coaxially aligned wheels **152** and at least one steering wheel **166**. It should be understood that a mover **104** can have three or more wheels depending the size of the mover and the weight of the object being

transported and the number of wheels necessary to provide stability to the mover when transporting the object. It should also be understood that the wheels can be in different forms, such as but not limited to round wheels, circular wheels, Omni wheels, Mecanum wheels or other forms capable for allowing the mover to travel along the surface being traveled. Preferably, propulsion system **106** of the mover **104** includes a battery **168** that operates to energize one or more electric propulsion motors **170** for driving coaxially aligned wheels **152**. It should be understood that in certain preferred embodiments of the invention the battery could be replaced by transmitting electrical current such as by the mover electrically contacting electrical tracks mounted along the path for supplying power to the various systems mounted to the mover. Preferably, the wheels are formed having rubberized, vinyl or plastic tread bands thereon to minimize vibration and wheel slippage during travel. The propulsion system **106** further includes an electric steering motor **172** that is mechanically coupled to the steering wheel **166** and operates to navigate the mover **104** by rotate the steering wheel **166**. In another preferred embodiment, the steering wheel **166** is a freely rotating wheel. In operation, the electric propulsion motors **170** operate to rotate the coaxially aligned wheels **152** by different amounts to cause angular displacement and change in direction of travel of the mover **104**. In a preferred embodiment, by operating each of the electric propulsion motors **170** independently forward and backwards at variable speeds, the mover can travel in both the x and y directions. In a preferred embodiment, each mover **104** further includes a plastic or metal cover **174** with a front end **176** having a lower in height and a bumper assembly **178** protruding outwardly and a back end **180** having an indented section **182** with a configuration such that it can mate with the bumper assembly of another mover thereby allowing multiple movers to fit together to

achieve a smaller product pitch than the movers real un-nested length while maintaining mover stability.

[0100] In a preferred embodiment, the plastic or metal cover or encasement **174** is a washed down rated plastic or metal removably or permanently positioned around the mover **104** such that protects or shelters the mover's electronics and electric propulsion and steering motors during washing and cleaning of the mover. It should be understood that since the movers operate using a wireless command system, the only openings in the cover **174** that are required are the openings **184** for the wheel axles **184** which can be protected using non-water permeable rubber gaskets (not shown) or the like to prevent water leakage through such openings **184**.

[0101] Referring to **FIG. 15**, each mover includes a palette section **188** for support an object thereon and an object transfer mechanism **190** for transferring the object from the palette section **188** to an object receiving platform **192** at a loading and/or unloading station (end point) **120**. It should be understood that such object transfer mechanism **190** can be a conventional mechanism such as pallet rollers or bearings spaced across the surface **194** of the palette section **188** permitting easy horizontal of an object resting on the palette section **188** such that the object transfer mechanism **190**, such as an arm assembly, hydraulic system, chain system, robotic arm system, and the like operates to transfer the object from the palette section **188** to the object receiving platform **192**. In another preferred embodiment the object transfer mechanism **190** is a lifting mechanism that lifts one end of the palette section **188** upwardly so that the object resting on the palette section **188** slides forwardly towards the object receiving platform **192**.

[0102] In another preferred embodiment of the invention, as illustrated in **FIGs. 16 and 17**, the mover system **100** includes a track **196** having a general U-

shape configuration with a bottom wall **198** and a pair of parallel side walls **200** extending perpendicularly upwardly from the bottom wall **198**. Preferably, the track is formed from steel or other magnetic conducting material having one or more generally straight sections **202** and one or more curved sections **204** creating a closed loop track having a start point **118** for use by the master controller **102** to coordinate the location of a mover **104** along the track **196** and one or more end points **120**. In another preferred embodiment if a mover is operating along a predefined platform, the curve sections **204** are in the form of clothoid arcs, which includes banking **203** (**FIG. 18**) along the outside of the track **196** that operates to reduce wheel slippage and/or to reduce the effects of centripetal force acting on the mover. In another preferred embodiment, the curved sections **204** are in the form of clothoid or approximate clothoid arcs for minimizing any abrupt variations in curvature that can cause variation in centripetal force acting on the mover as it travels along the track. It should be understood that the track **196** can further include one or more side paths **124** (**FIG. 2**). As shown in **FIG. 17**, the propulsion system **106** includes at least one electromagnetic levitation coil **206** mounted to the inner surface **208** of the bottom wall **198** of the track **196** that is effective for creating an electromagnetic field, and one or more magnets **210** mounted to the undercarriage **162** of each mover **104**. Once energized, the electromagnetic levitation coil **206** generates an electromagnetic field that provides a repelling force against the electromagnetic fields created by the one or more magnets **210** allowing the mover **104** to levitate above the bottom wall **198** of the track **196**. In another preferred embodiment, the propulsion system **106** further comprises a plurality of electromagnetic propulsion coils **212** effective for creating electromagnetic fields mounted along the inner surfaces **214** of the parallel side walls **200**. The electric

current energizing the electromagnetic propulsion coils **212** is constantly alternating to change the polarity of the magnetized propulsion coils **212** that reacts with magnetic fields created by propulsion magnets **216** mounted along the sides **218** of each mover **104** to create forward or backward motion of the movers **104**. In order to reduce the likelihood of a mover **104** contacting the track **196**, a plurality of side electromagnetic levitation coils **219** and a plurality of proximity and speed sensors **220** are placed along the side walls **200** of the track **196** which electronically communicates with the master controller **102** that operates to continuously adjust the energizing voltage to the one or more electromagnetic levitation coils **219** to correct the position of the mover **104** so that it maintains its proper distance from the side walls **200** of the track **196** thereby preventing a mover from contacting a side wall during operation. In a preferred embodiment of the invention, tracking sensors **148** are positioned along the track **196** and each are electronically coupled to the master controller **102** and operate to accurately update the position of the mover **104** at any known point along the track **196** thus verifying the actual position **146** of each mover **104** traveling along the track **196**. It should now be apparent to one skilled in the art that control tracking sensors **148**, such as visual cameras, allow for a relatively inexpensive way to resynchronize a mover **104** traveling along the track **196**.

[0103] In another preferred embodiment of the invention the master controller **102** operates to adjust the energizing of the electric propulsion coils **212** to change the plan parameters **128** of the movers **104** such that the movers arrive at their scheduled end points **120** at their scheduled times. Further, it should now be apparent that changing the plan parameters **128** of the movers **104** can be used to increase or decrease the pitch between movers **104** as they travel along the track **196**. In an exemplary illustration, by reducing the speed of a first mover relative to

the speed of a second mover that is traveling ahead or behind the first mover will result in increasing the pitch or distance between the two movers. It should be understood that the master controller further operates to monitor the positions and speeds of each mover traveling along the track and adjusts the speed of the movers to maintain their relative positions to each other in accordance with the predefined virtual path and plan parameters. It should also be understood that in a preferred embodiment of the invention the motion controller operates by adjusting the plan parameters of a mover as it travels along from one end point to another along the track to ensure that the mover arrives at a defined end point at its scheduled time.

[0104] In another preferred embodiment of the invention, as illustrated in **FIGs. 19** and **20**, the bottom wall **198** and side walls **200** of the track **196** are provided with propulsion coils **212** that cooperate with magnets **210** on the undercarriage **162** and/or sides **218** of the mover. It should be understood that propulsion coils **212** can be arranged along the bottom wall **198** of the track **196** in both the x and y directions that operate to direct a mover **104** in both x and y directions along their predefined virtual vector path **116** along the track **196** and/or along the side walls **200** in both the x and z directions that operate to direct the mover **104** in both x and z directions. Preferably, magnets **210** and **216** are arranged in a conventional alternating north and south pole arrangement using bearings or sliding self-lubricating plastic between the mover and the bottom wall **198** of the track **196**. In another preferred embodiment the magnets mounted along the undercarriage **162** of the mover **104** are in a conventional Halbach array pole arrangement that operates to levitate and create movement of the mover **104** during operation. Preferably, the propulsion coils are sized and placed so there are at least six coils that operate together to affect motion of a mover in both the x and y

directions and/or the x and z directions. In another preferred embodiment, tracking sensors **148** are positioned along the track **196** and are electronically coupled to the master controller **102** to operate to accurately update the position of the mover **104** at any known point along the track **196** thereby verifying the actual position **146** of each mover **104** traveling along the track **196**. The individual propulsion coils **212** can then be energized or de-energized to adjust the x and y direction of movement as well as the plan parameters **128** for the mover to ensure that the mover arrives at the scheduled end point **120** at its scheduled time. While the use of levitation and propulsion coils have been described along the bottom and/or sides of the track and levitation and propulsion magnets have been described as being mounted on a mover, it should be understood that in another preferred embodiment the levitation and propulsion coils can be positioned on the mover and the levitation and propulsion magnets can be mounted along the bottom wall and/or the side walls of the track.

[0105] Referring to **FIG. 21**, another preferred embodiment of the moving system of the subject invention is shown having a track **196** having a bottom wall **198** and parallel side walls **200** extending perpendicular upwardly from the bottom wall **198**. Positioned along the upper surface **222** of the bottom wall **198** is a plurality of rollers (or castor wheels) **224** for supporting a mover **104** thereon. Each roller **224** is swiveled mounted to the bottom wall **198** and each connected to a pair of motorized rotary servomotors **226**. One servomotor **226** operates to control the angle of the roller **224** and the other rotary servomotor **226** operates to drive (rotate) the roller **224**. In operation, the master controller **102** functions to direct a mover **104** along its predefined virtual vector path **116** by transmitting motion commands **126** to the servomotors **226** such that the servomotors **226** change the angle of the rollers **224** when supporting a mover **104** and the rotational speeds of the rollers **224** to

direct the mover traveling along the track **196** to its proper end point **120** at its scheduled time. It should be understood that in the event a mover is ahead of schedule or behind schedule, the master controller **102** can transmit motion commands **126** to change the mover's plan parameters **128** to ensure that the mover arrives at its end point at the proper scheduled time. In order to maintain stability of the mover, preferably the mover has a relatively square bottom configuration and the rollers are sized so that at least four rollers are positioned constantly underneath the mover as it travels along the track. Preferably, the rollers are arranged as a two by two square and spaced at a minimum of one half the width and length measurement of the mover. If two movers share a same roller, the movers are separated by driving the other rollers underneath the movers while not driving the shared roller thereby causing the movers to slip or slide off the shared roller. In a preferred embodiment, the rollers are formed from steel conveyor rollers and the undercarriage **162** of the movers **104** are made of rubber or a soft sanitary plastic that passes wash down requirements. In another preferred embodiment, the undercarriage **162** of the movers **104** is formed from a wearable material which can be easily replaced.

[0106] In another preferred embodiment of the invention the master controller **102** further operates to determine the difference between the actual position **146** of a mover **104** and its scheduled position **158** along the mover's predefined virtual vector path **116** and uses the comparison to determine the probability that one or more of the wearable parts on the mover needs replacement. For a non-limiting example, if a mover is traveling slower than the scheduled speed at a discrete point along the predefined virtual path, the master controller automatically sends a notice for display on the human-machine-interface that the mover is in need of servicing.

[0107] In a preferred embodiment, as illustrated in **FIG. 22**, the mover system **100** further includes one or more convention mechanical systems **228** for securing the position of a mover **104** and/or an object **12** when it arrives at an end point **120**. The mechanical systems **228** operate to minimize any movement of the object as it receives an operation (such as a mechanical manufacturing operation) thereon. In another preferred embodiment, as illustrated in **FIG. 23**, the mover system **100** includes mover positioning apparatus **230**, such as guide rails, that operate to guide a mover **104** as it approaches an end point **120** so that the mover, or an object thereon, is precisely aligned with the secondary equipment **10** at the end point **120**.

[0108] In another preferred embodiment of the invention, as illustrated in **FIG. 2**, the predefined virtual vector path **116** is defined such that a mover **104** is directed to a battery charging station **232** that operates to allow a mover to exchange a discharged battery on the mover for a charged battery stored at the battery charging station. In another preferred embodiment the battery and the battery charging station operate, such as through induction, whereby the batter charging station includes induction coils **234** that operate to charge a battery **168** (**FIG. 15**) as it travels along its path **108** and past the induction coils **234**. It should be understood that the battery charging station **232** can be positioned along the path **108** traveled by a mover **104**, such as for a mover system where the movers travel a routine path (constant predefined virtual paths) or can be located along a side path **124**. For a non-limiting illustration, during operation when a battery on a mover indicates, such as by a meter or charging is determined by prescheduled schedule, the master controller or the mover's control system operates to direct the mover to a battery charging station. If in the event the master controller and/or the mover's control system operates to determine that the charging or replacement of the batter will

impact the time that the mover will reach an end point, the master controller and/or mover's control system operates to adjust, modify or creates a new predefined virtual vector path and/or operates to adjust the plan parameters to ensure that the mover arrives at the end point at its scheduled time. It should now be understood that by mounting a battery along the side or near the undercarriage of the mover permits the battery to be charged as the mover travels in close proximity to the charging station. In another preferred embodiment, the charging station can include contacts **235** that contact the mover as it travels past the charging station such that it provides electrical current to charge the battery on the mover. It should be understood that the number of charging stations is dependent on the size of the battery to be charged, battery usage, the amount of time that the mover is in close proximity (as well as how close of proximity, such as to an induction coil) or in contact with the charging station.

[0109] In operation, as illustrated in **FIG. 24**, a predefined virtual vector path having a start point and one or more end points for a mover is inputted into the master controller (**step 300**). Preferably, one such method uses conventional software visualization whereby an operator inputs control information, such as by use of the human-machine-interface. The master controller transmits through a communication network control motion commands and plan parameters to the mover control system (**step 302**) for following the predefined virtual vector path. In a preferred embodiment the operator utilizes a global coordinate bounding box (control area) whereby the 0, 0 (x, y coordinates) is defined as the start point and a vector path (predefined virtual vector path) is drawn (defined) as a closed loop within the bounding box. Conventional control software, such as Allen Bradley Logix software, Siemens Simotion software, Beckhoff TwinCAT software, and the like, is then used to

create mover motion commands that are used to direct the mover's propulsion system to follow the predefined virtual vector path (**step 304**). In another preferred embodiment the vector path (predefined virtual vector path) is inputted into the mover control system using conventional hardware training systems whereby sensing hardware capable of tracking its location within a control area is moved along a path and its movement (position) is continuously tracked, recorded and used to conventionally create a predefined virtual vector path. It should be understood however that other systems can be utilized to create predefined virtual vector paths, such as a hybrid method whereby a base virtual vector path, such as a simple oval, is created using conventional software visualization system and small sections of the path is modified, such as by use of a conventional hardware training system. It should also be understood that a virtual vector path may also require optimization, adjustment or precision guidance, such as by a programmer making adjustments to the predefined virtual vector path, to ensure a mover is properly aligned upon arrival at a particular work station (end point).

[0110] During operation, the master controller receives information from the path tracking system for each mover and the various detection systems and calculates and/or monitors the actual positions of each mover (**step 306**). The traffic control system of the master controller continuously operates to compares each mover's actual position with its scheduled position to ensure that a mover does not contact (collide) with an obstruction or another mover as they move along their predefined virtual vector paths (**step 308**). If a mover's actual position is different than its scheduled position, it utilizes standard proportional, integral, derivative (PID) control loop theory to produce corrective velocity commands (or path alterations) which are transmitted to the mover's control system which operates to forward the

commands to the mover's propulsion system (**step 310**). In another preferred embodiment of the invention the master controller operates to monitor the operation of each mover and uses statistical analysis to determine if a mover is requiring repair or maintenance (**step 312**) and if so operates to transmit control commands to the mover control system and cooperates with the mover control system to provide mover control commands to the mover's propulsion system to direct the mover to a location for the repairs or maintenance (**step 314**). The master controller further operates to select another mover and provides the mover's control systems with control commands and plan parameters to replace the mover being repaired or requiring maintenance. In this way, the system for transporting objects can operate without alteration or interruption. For a non-limiting exemplary illustration, as the speed of the various over all assembly or operation (master axis) being serviced by the system for transporting objects of the subject application increases, the speed of operation of the individual components of the master axis can increase. As the speed of the master axis slows down or stops, the system for transporting objects can slow down or stop. Thus, the overall operation of the master axis can remain synchronized.

[0111] It should now be apparent that the subject invention is a new and novel mover system for transporting objects having a plurality of independently controlled autonomous movers operating along an adjustable predefined virtual vector path, that allows an operator to easily modify the path of one or more of the movers, that operates to modify the movement (path parameters and path of travel) of each mover to ensure that each mover arrives at a predetermined end point (destination) at a predetermined specified time. Each mover includes a tracking system that provide absolute location coordinates and a mover control system that transmits the

mover's position to a master controller. In another preferred embodiment the mover system includes one or more detection systems that cooperate with the tracking system to ensure that the mover does not contact (collide) with an obstruction or another mover. Accordingly, the master physical or virtual axis of an industrial operation can be synchronized with the mover system.

[0112] It should also now be apparent that the mover system of the subject invention provides a new and novel system whereby independent movers can operate along predefined virtual vector paths and arrive precisely at an end point to position an object being transported thereon to be in proposition for loading, unloading or having an operation performed thereon. It should also be apparent that the mover system of the subject invention operates such that an interruption in a mover's travel is automatically compensated for, such as by adjusting or modifying the mover's predefined virtual vector path and/or plan parameters, such that the mover arrives at its end point and its scheduled time. Further, the system operates such that each mover is monitored and analyzed to determine if the mover requires maintenance, and if so, the system automatically operates to notify an operator, such as by way of a HMI, or automatically operates to direct the mover along an alternative path for maintenance. The system further operates to direct a new mover along a predefined virtual vector path under appropriate plan parameters so that the new mover arrives at the old mover's end point at the scheduled time. Thus, the mover system operates to minimize interruption of the system caused by mover maintenance requirements. Further, by use of battery charging stations positioned within the control area or path of travel of the movers, the mover can operate continuously without the need of stoppage for battery charging or replacement. Thus, in view of the foregoing, it should now be apparent that the subject invention

provides a mover system that permits one or more movers to operate independently along predefined virtual vector paths to arrive at one or more endpoints at scheduled times and minimizes interruptions.

CLAIMS

1. A mover system for transporting objects from a start point to an end point such that the object arrives at the end point at a scheduled time, the mover system comprising:

a mover having a mover control system that operates to direct said mover to follow a predefined virtual vector path utilizing plan parameters;

a master controller;

a communication network in communication with said master controller and said mover control system;

wherein said master controller operates to determine a calculated position of said mover and transmits motion commands using said communication network to said mover control system that modifies said plan parameters and/or said predefined virtual vector path to move said mover so that said calculated position matches a scheduled position for said mover.

2. The mover system of Claim 1 wherein said master controller operates to periodically adjust said plan parameters so that said mover arrives at the end point at the selected time.

3. The mover system of Claim 1 wherein said master controller operates such that the mover system is synchronized with the operation of secondary equipment operating in conjunction with the mover system.

4. The mover system of Claim 1 further comprising a detection system in communication with said mover control system such that if said detection system detects an obstruction, said mover control system operates to create a new defined virtual vector path and transmits mover control commands to a propulsion system that operates to move said mover along said new defined virtual vector path.

5. The mover system of Claim 1 further comprising a path tracking system that operates to identify specific locations along said predefined virtual vector path.

6. The mover system of Claim 5 wherein said path tracking system comprises one or more navigation devices that operate to provide information to said mover control system which operates to calculate the actual position of said mover and further operates to create a comparison of said actual position with a scheduled position and uses said comparison to modify or create a new predefined virtual vector path and/or to modify said plan parameters so that said mover arrives at an end point at a scheduled time.

7. The mover system of Claim 5 wherein said path tracking system comprises navigation devices in the form of magnetic or inductive markers that operate to provide location information to said mover control system when detected by tracking sensors positioned on said mover and wherein said tracking sensors are angled magnetoresistive or inductive sensors arranged in a pattern on said mover and operate to provide said mover control system with direction of travel of said mover.

8. The mover system of Claim 5 wherein said path tracking system comprises navigation devices in the form of radio frequency identification tags positioned within a control area and operate to transmit absolute location coordinates to said mover control system.
9. The mover system of Claim 1 wherein said mover comprises a pair of coaxially aligned wheels and at least one steering wheel and a cover having a bumper assembly and an indented section configured to mate with a bumper assembly of another mover to minimize pitch between movers.
10. The mover system of Claim 1 further comprising a propulsion system that operates to move said mover along said predefined virtual vector path using magnetic levitation and propulsion.
11. The mover system of Claim 10 wherein said propulsion system comprises a plurality of electromagnetic propulsion coils arranged to permit said mover to move in two dimensions.
12. The mover system of Claim 10 wherein said propulsion system comprises a plurality of electromagnetic propulsion coils arranged to permit said mover to move in three dimensions.
13. The mover system of Claim 1 wherein said predefined virtual vector path includes one or more curves in the form of clothoid or approximate clothoid arcs.

14. The mover system of Claim 1 wherein said predefined virtual vector path includes one or more curves, wherein said one or more curves are banked such that centripetal force acting on said mover traveling along said one or more curves is minimized.

15. The mover system of Claim 1 further comprising a track having a bottom wall and a pair of parallel side walls extending upwardly from said bottom wall, wherein said bottom wall having at least one electromagnetic levitation coil that cooperate with one or more magnets mounted to said mover that operate to levitate said mover above said bottom wall and wherein said parallel side walls each having a plurality of side electromagnetic levitation coils and a plurality of proximity sensors that cooperate to prevent said mover from contacting said side walls.

16. The mover system of Claim 1 further comprising one or more battery charging stations that operate to charge a battery on said mover while said mover follows said predefined virtual vector path.

17. The mover system of Claim 1 further comprising a propulsion system and wherein said mover includes wheels such that said propulsion system operates to rotate at least one of said wheels to direct said mover's direction of travel.

18. The mover system of Claim 1 wherein said predefined virtual vector path includes a plurality of wheels for supporting said mover thereon, wherein each wheel is coupled to a motorized rotary servomotor that operates to drive said wheel and

control wheel angle to move said mover such that it follows said predefined virtual vector path.

19. The mover system of Claim 1 wherein said communication system uses multiple wireless frequencies bands to communicate for control and feedback in areas where high amounts of radio transmission interference (RTI) is present.

20. The mover system of Claim 1 wherein said communication system uses wireless communication for communicating with said mover in heavy RTI environments such that control commands are repeated using one or more wireless frequency bands to insure that communication packets are received by said mover control system.

21. The mover system of Claim 1 wherein said communication network comprises multiple antennas positioned around a control area for receiving tracking signals and whereby said master controller operates to measure the strength of said tracking signals and uses triangulation to determine the position of said mover in a global coordinate system.

22. The mover system of Claim 1 wherein said communication network uses one or more visual cameras that operate with said mover control system of said mover to identify key parts of a control area and transmit information to said master controller that functions to determine a global position for said mover in a global coordinate system.

23. The mover system of Claim 1 wherein said master controller operates to vary said path parameters of said mover as it follows said predefined virtual vector path to reposition and resynchronize said mover in relation to other movers.

24. The mover system of Claim 1 wherein said master controller calculates changes in plan parameters and/or changes in said predefined virtual vector path needed to ensure said mover arrives at an end point at a scheduled time and determines the probability that one or more of the wearable parts on said mover needs maintenance.

25. A mover system for transporting objects from a start point to an end point such that the object arrives at the end point at a scheduled time, the mover system comprising:

- a mover having a cover and a mover control system that operates to direct said mover to follow a predefined virtual vector path utilizing plan parameters;

- a propulsion system;

- a master controller;

- a communication network in communication with said master controller and said mover control system;

- a detection system in communication with said mover control system such that if said detection system detects an obstruction, said mover control system operates to create a new defined virtual vector path for said mover and transmits mover control commands to said propulsion system to move said mover such that it follows said new defined virtual vector path;

a path tracking system having navigation devices that operate to provide location information to said mover control system;

wherein said master controller cooperates with said path tracking system to determine a calculated position of said mover and transmits motion commands using said communication network to said mover control system that modifies said plan parameters and/or said predefined virtual vector path to move said mover so that said calculated position matches a scheduled position for said mover.

26. The mover system of Claim 25 wherein said propulsion system comprises a plurality of electromagnetic propulsion coils that cooperate with propulsion magnets mounted to said mover.

27. The mover system of Claim 25 further comprising one or more levitation coils that cooperate with levitation magnets mounted to said mover that operate to levitate said mover about a platform.

28. The mover system of Claim 25 further comprising a track having a plurality of rollers for supporting said mover, wherein said plurality of rollers operate to rotate and swivel to direct said mover in a desired direction and speed along said track.

29. The mover system of Claim 25 wherein said mover includes a cover positioned around said mover and operates to protect a mover's electronics when said mover is washed.

30. The mover system of Claim 29 wherein said cover includes a bumper assembly and an indented section configured to mate with a bumper assembly of another mover to minimize pitch between movers.

31. A mover system for transporting objects from a start point to an end point along a path of travel such that the object arrives at the end point at a scheduled time, the mover system comprising:

- a mover having a mover control system that operates to direct said mover to follow a predefined virtual vector path utilizing plan parameters;

- a master controller;

- a communication network in communication with said master controller and said mover control system; and

- a path tracking system having navigation devices wherein said navigation devices are used to determine the actual position of the mover along the path of travel;

wherein said master controller operates to determine a calculated position of said mover and compares said calculated position with said actual position of said mover and adjusts said calculated position to correspond with said actual position of the mover.

32. The mover system of Claim 31 wherein said master controller compares said actual position of the mover to said predefined virtual vector path of the mover and transmits motion commands using said communication network to said mover control system that adjust said plan parameters to move said mover until said actual

position aligns with a predefined schedule position based on a specific time along said predefined virtual vector path for said mover.

33. The mover system of Claim 31 wherein said master controller operates to periodically adjust said plan parameters so that said mover arrives at the end point at the selected time.

34. The mover system of Claim 31 wherein said master controller operates such that the mover system is synchronized with the operation of secondary equipment operating in conjunction with the mover system.

35. The mover system of Claim 31 wherein said path tracking system further comprises radio frequency identification (RFID) tags positioned within a control area that cooperate with said navigation devices to accurately determine said actual position of the mover.

36. The mover system of Claim 31 further comprising a detection system in communication with said mover control system such that if said detection system detects an obstruction, said mover control system operates to create a new defined virtual vector path and transmits mover control commands to a propulsion system that operates to move said mover along said new defined virtual vector path.

FIG. 1

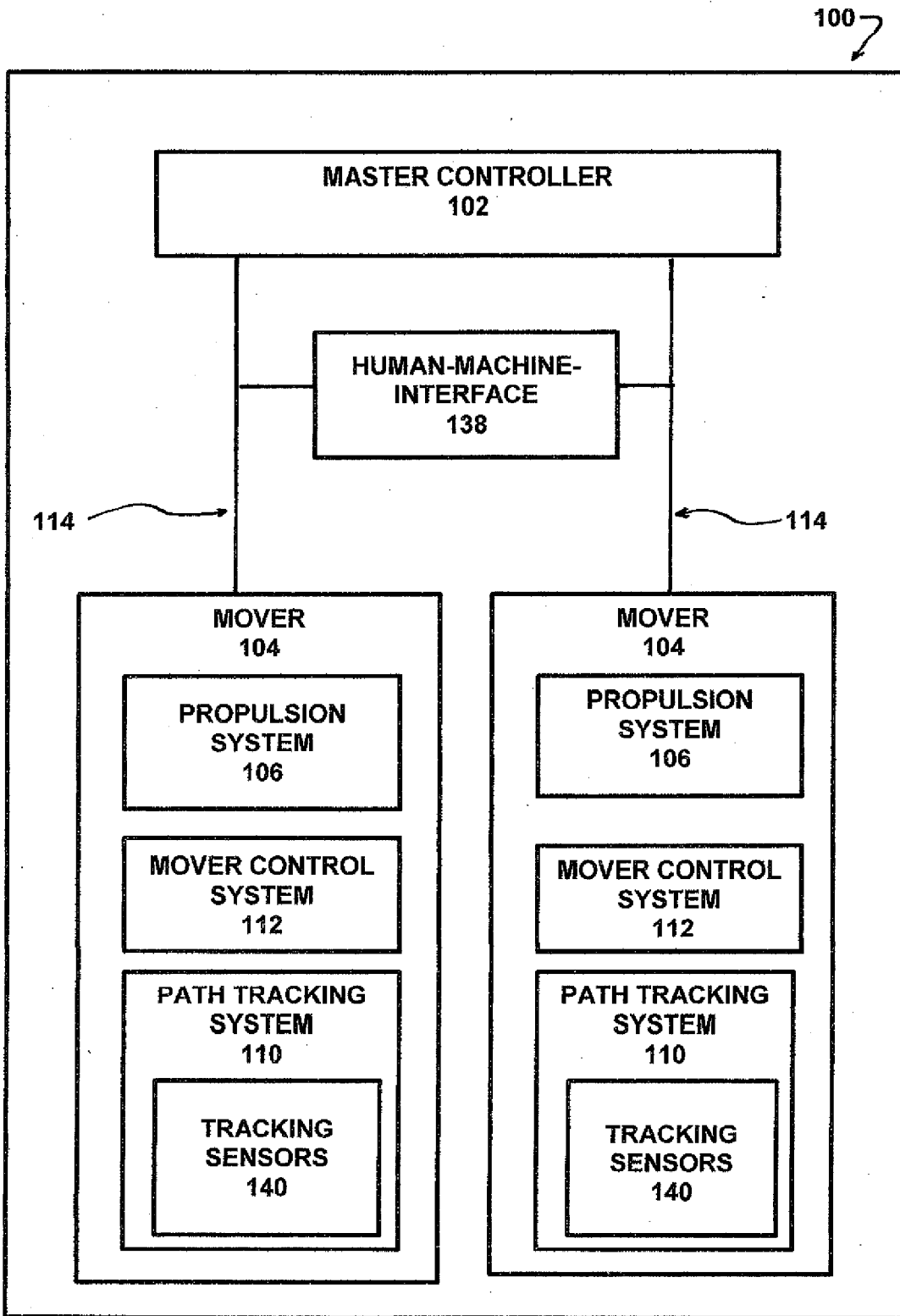

FIG. 2

2/24

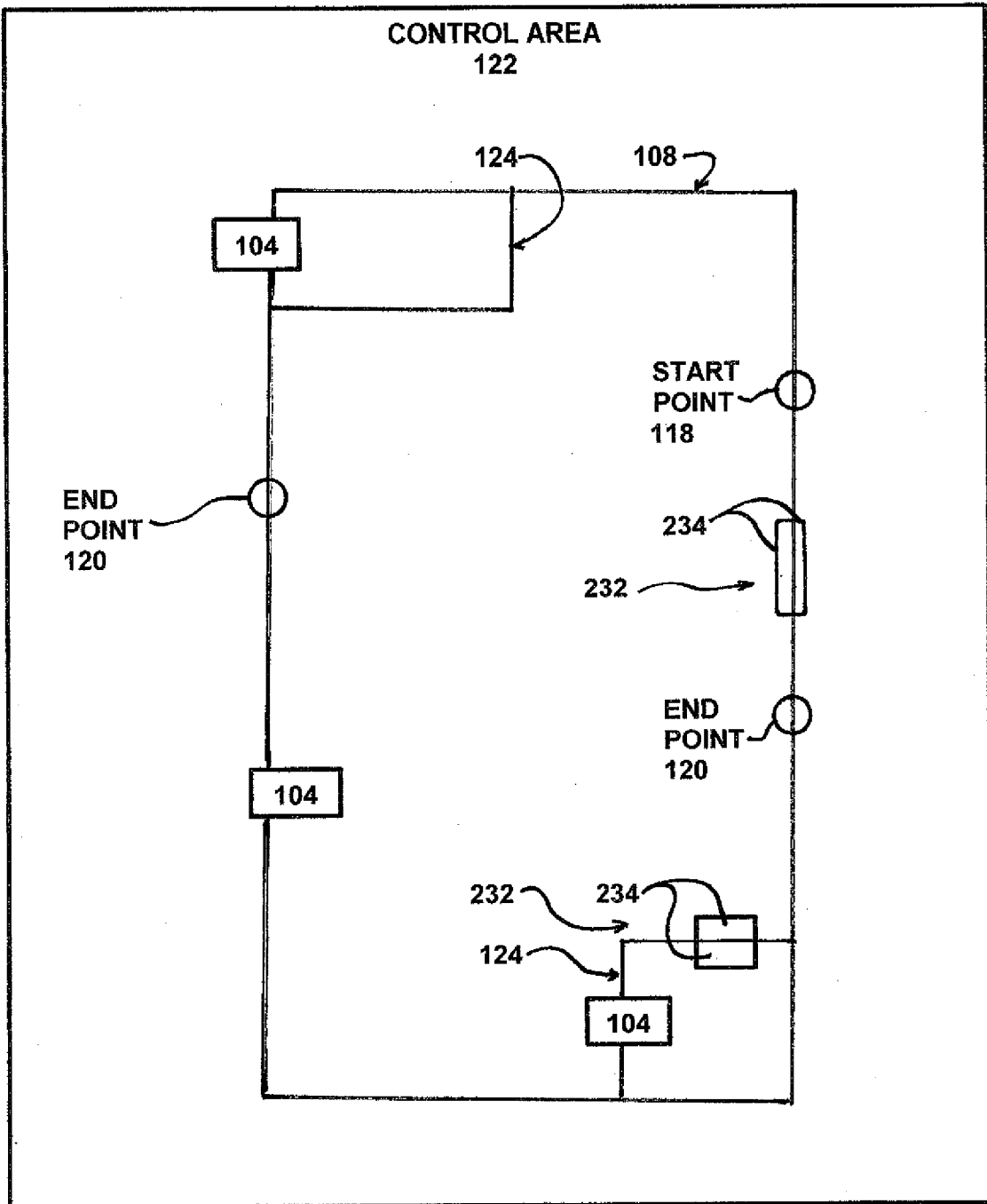

FIG. 3

3/24

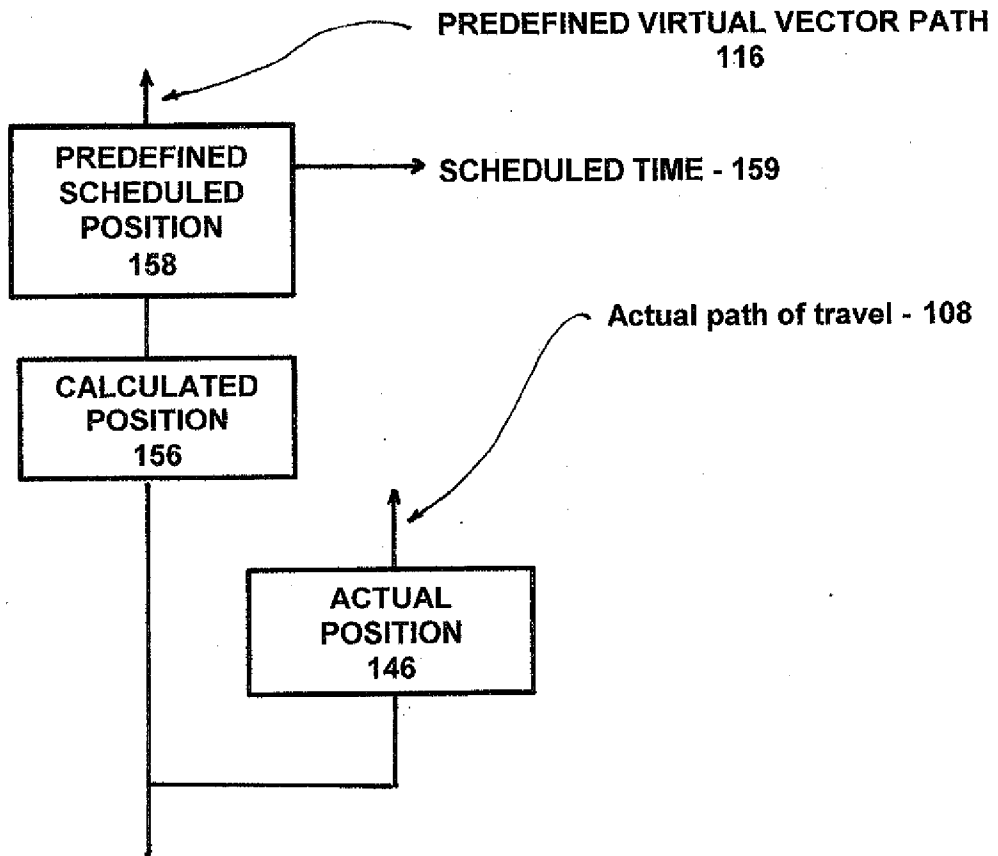

FIG. 4

4/24

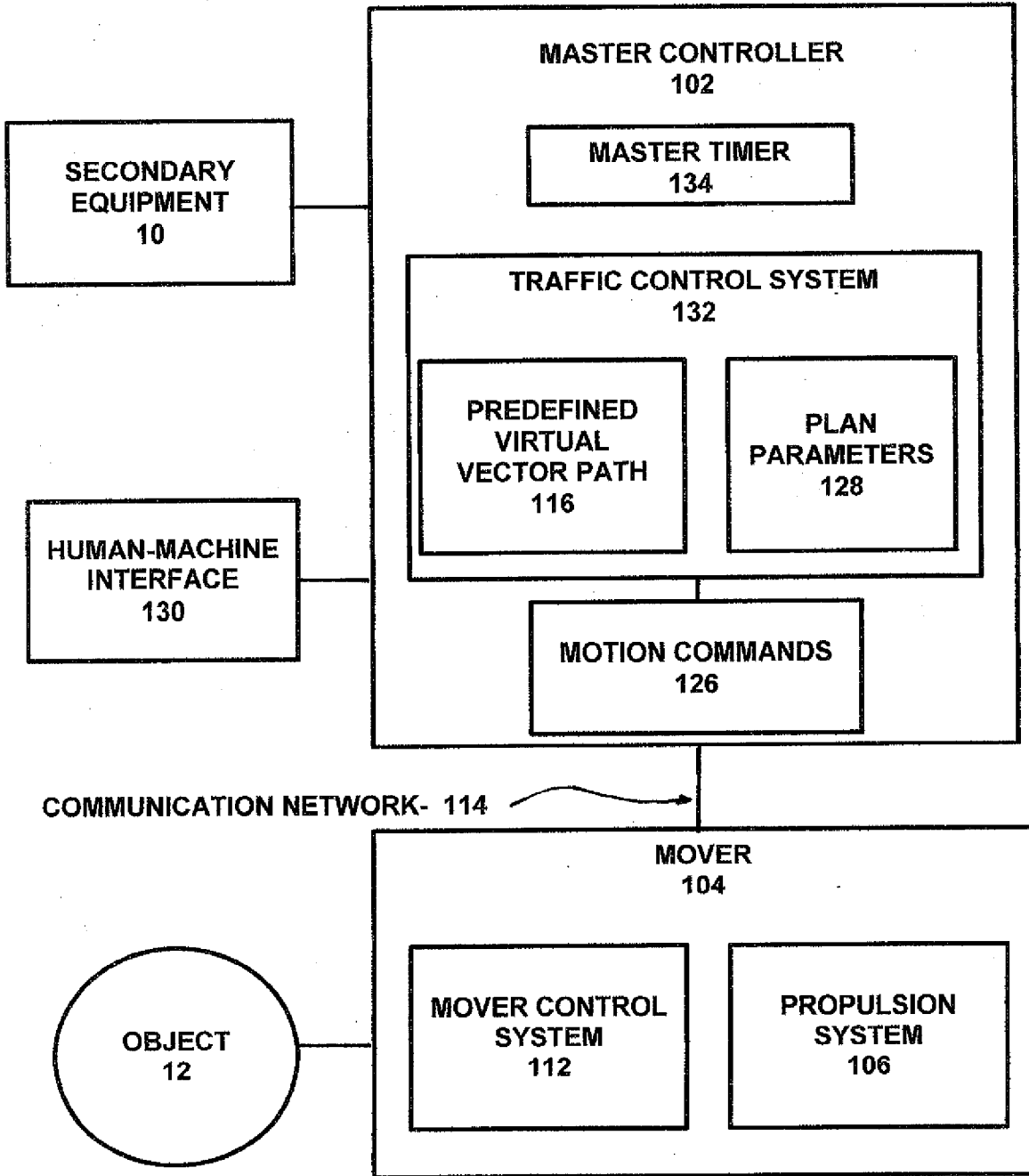

FIG. 5

5/24

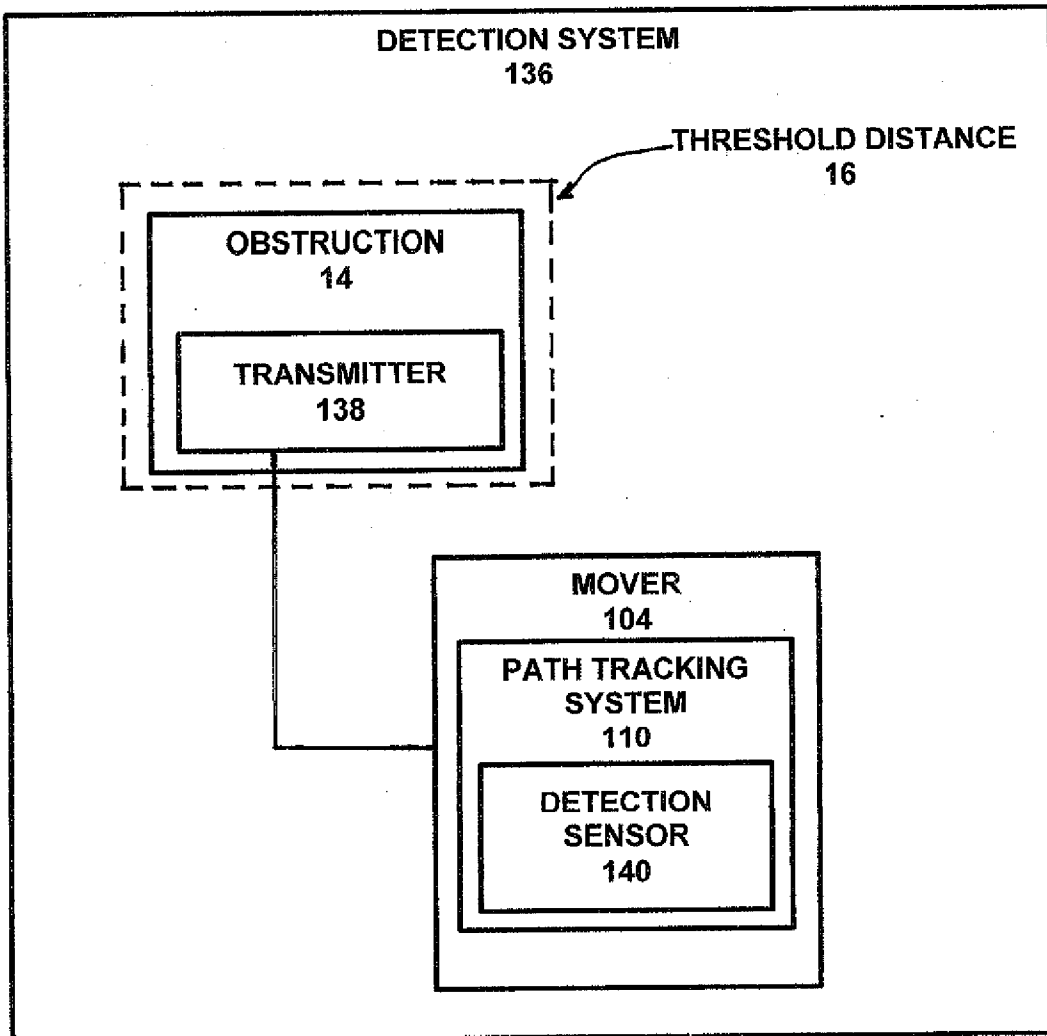

FIG. 6

6/24

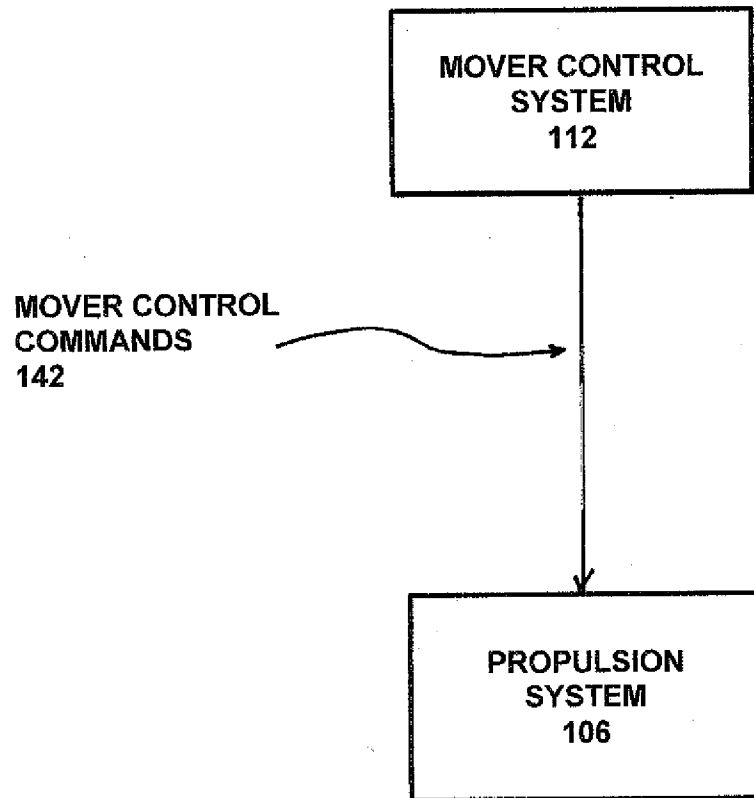

FIG. 7

7/24

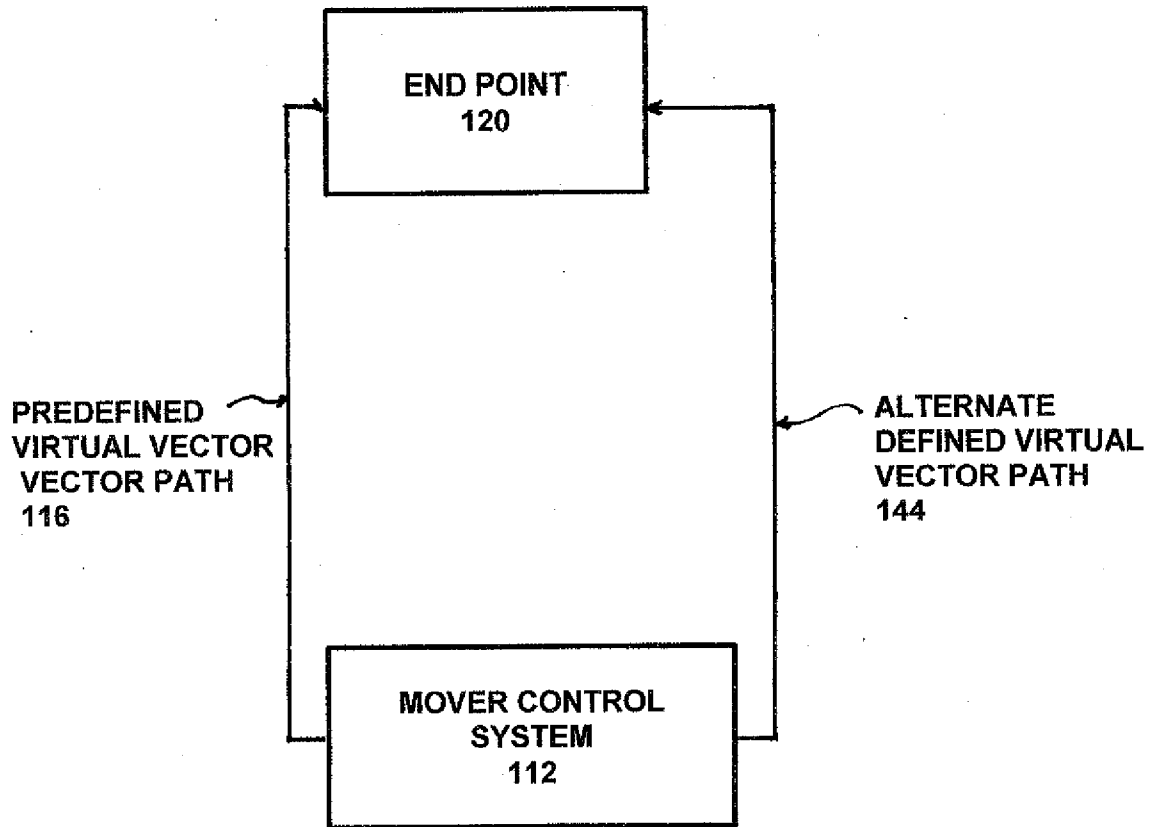

FIG. 8

8/24

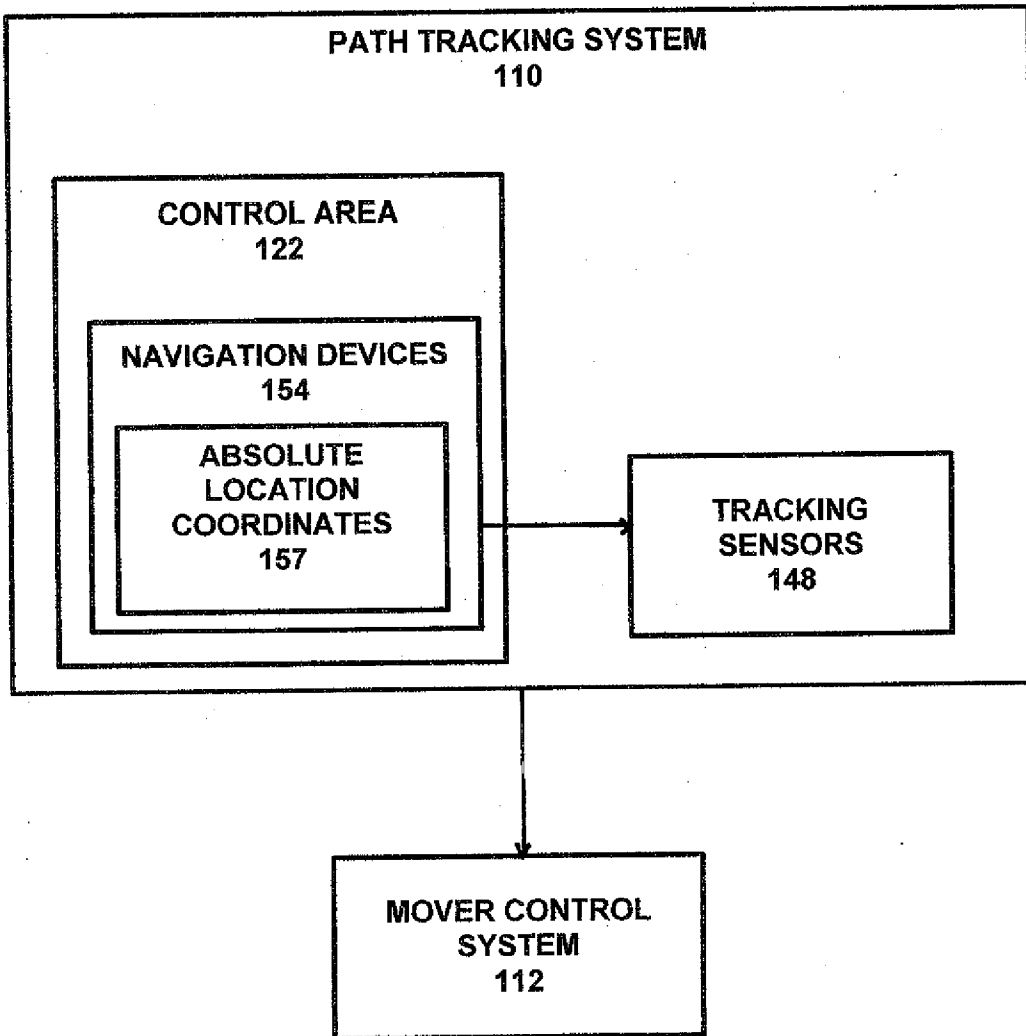

FIG. 9

9/24

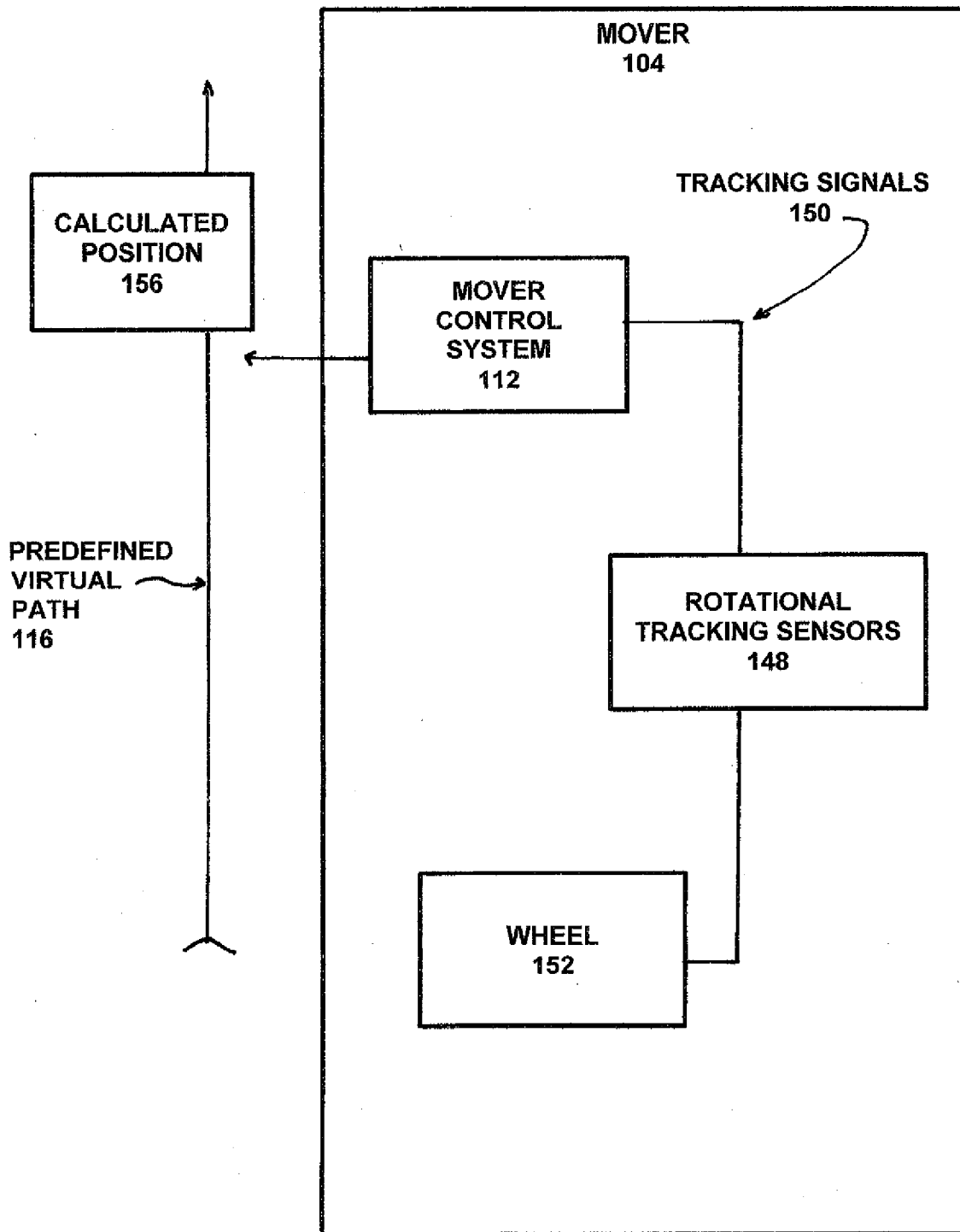

FIG. 10

10/24

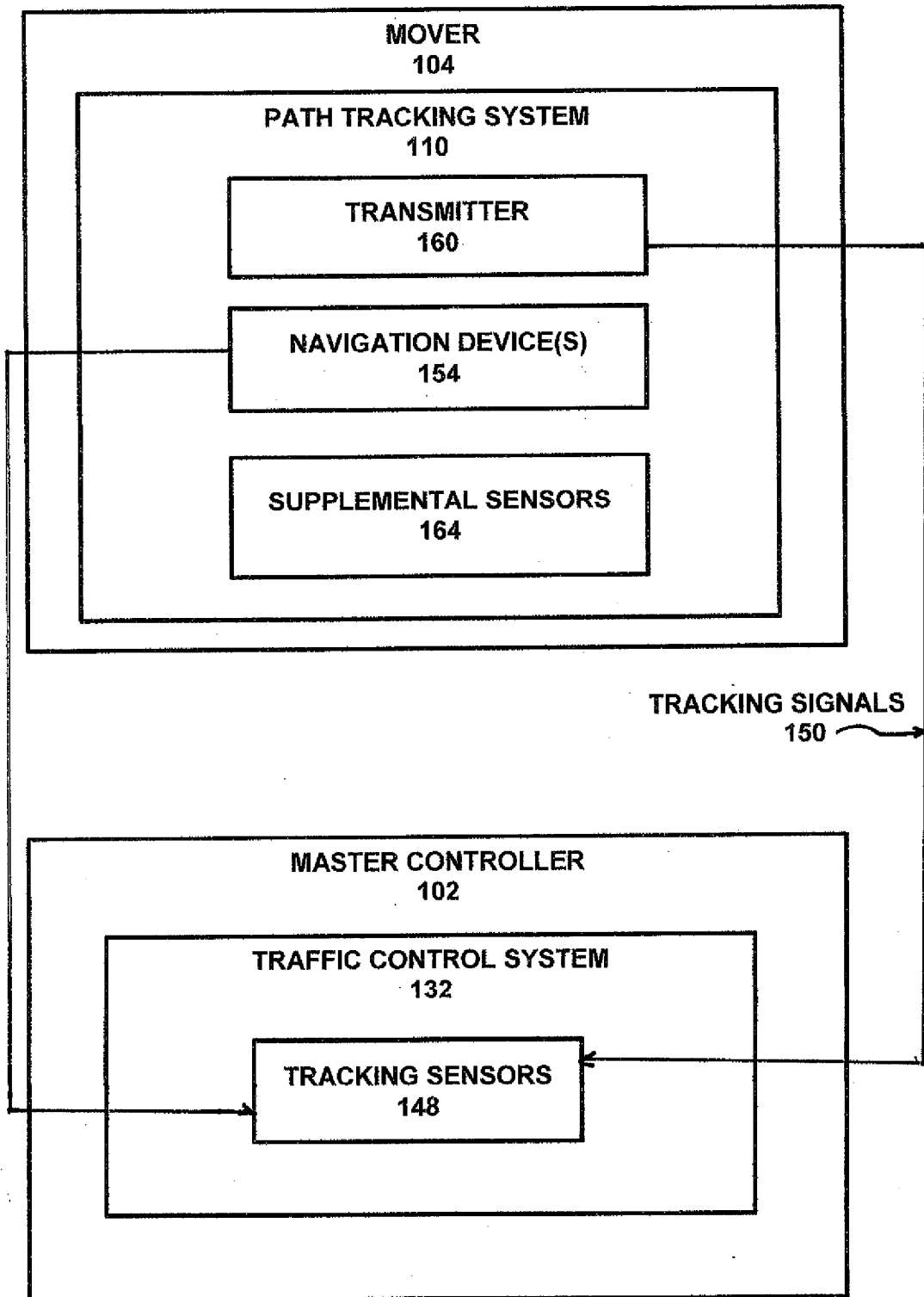

FIG. 11

11/24

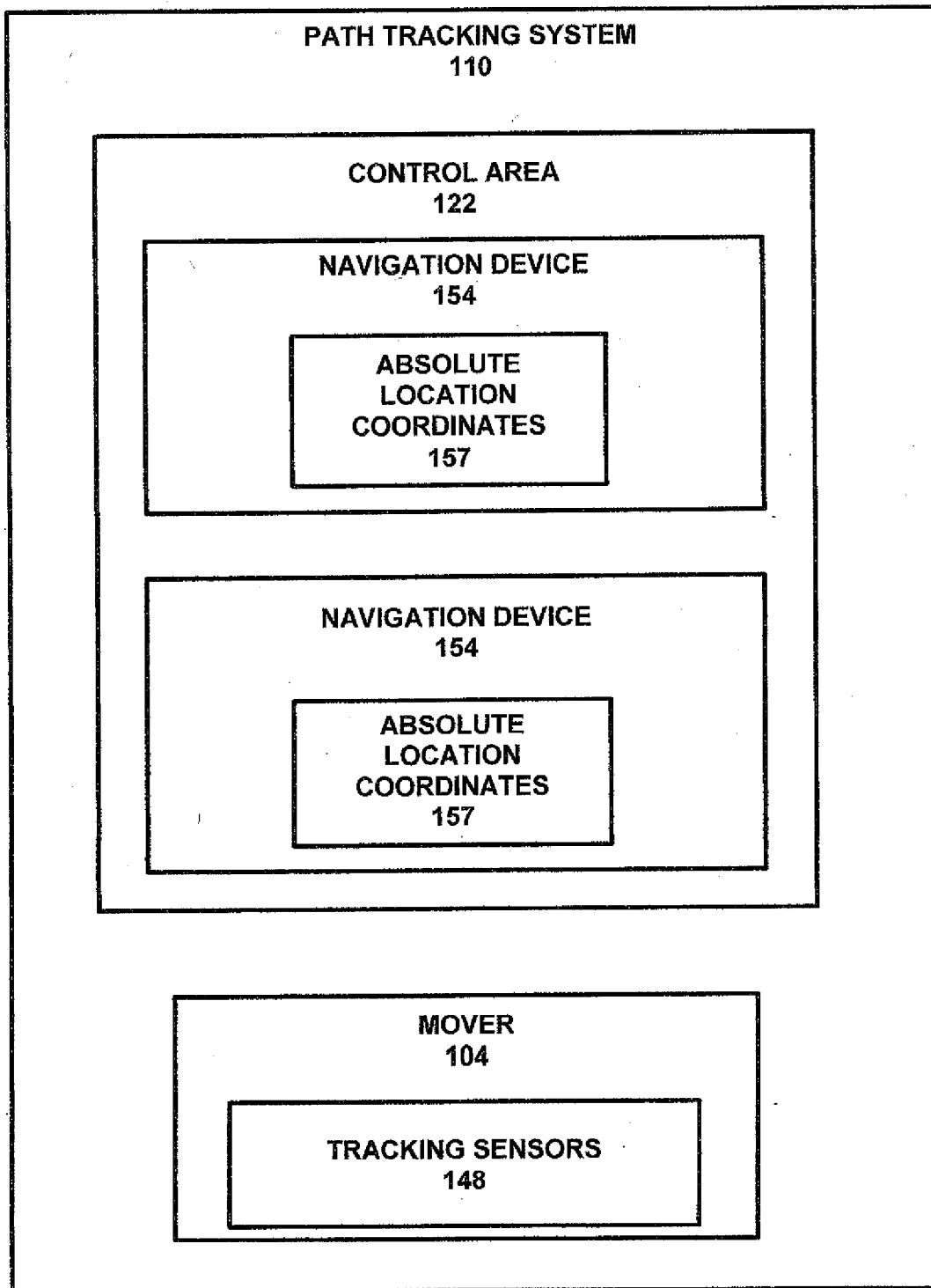

FIG. 12

12/24

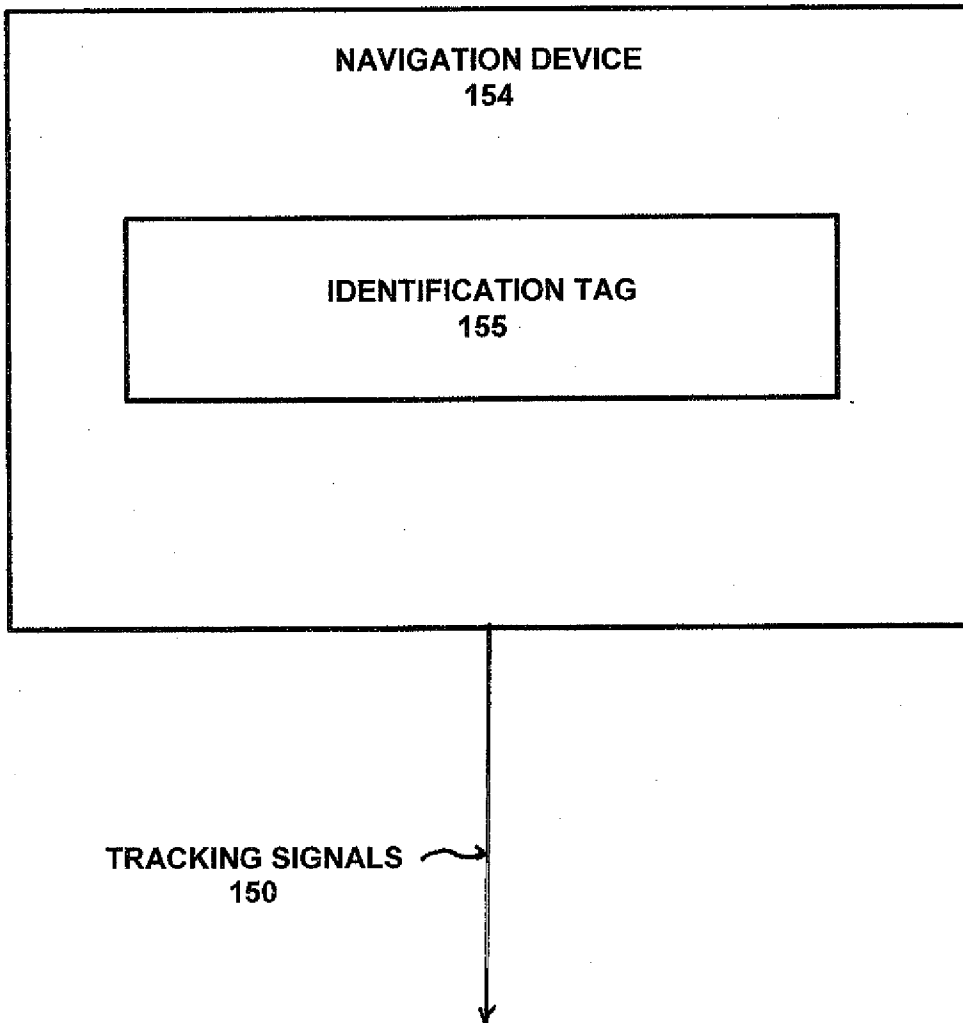

FIG. 13

13/24

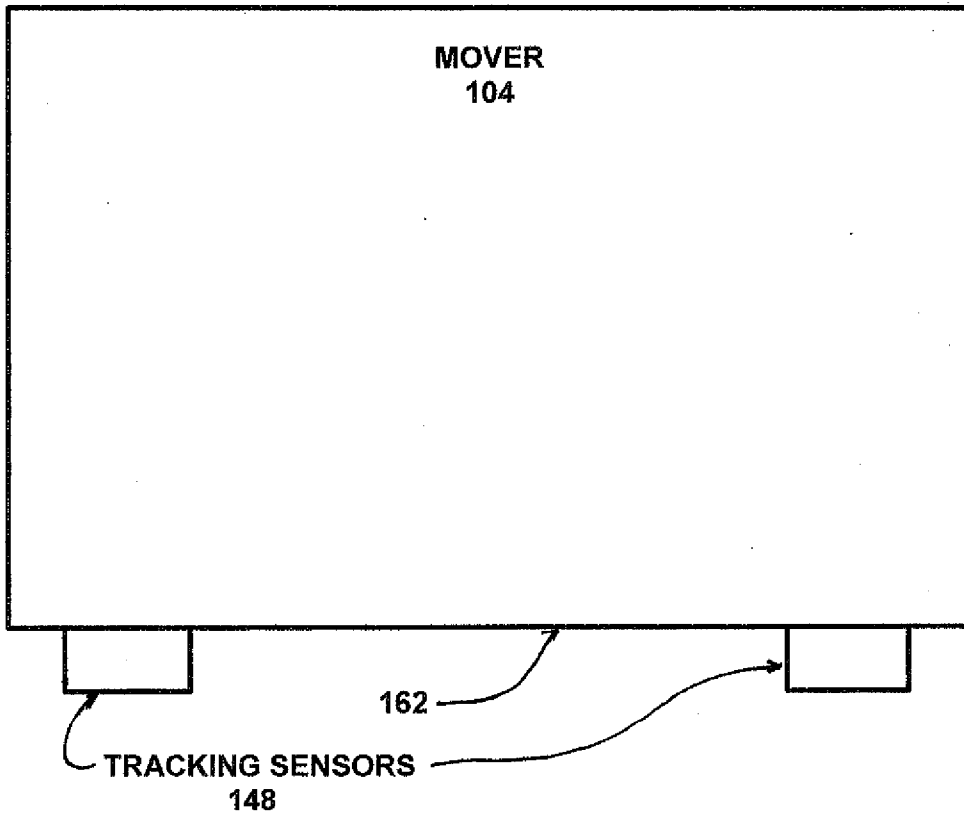

FIG. 14

14/24

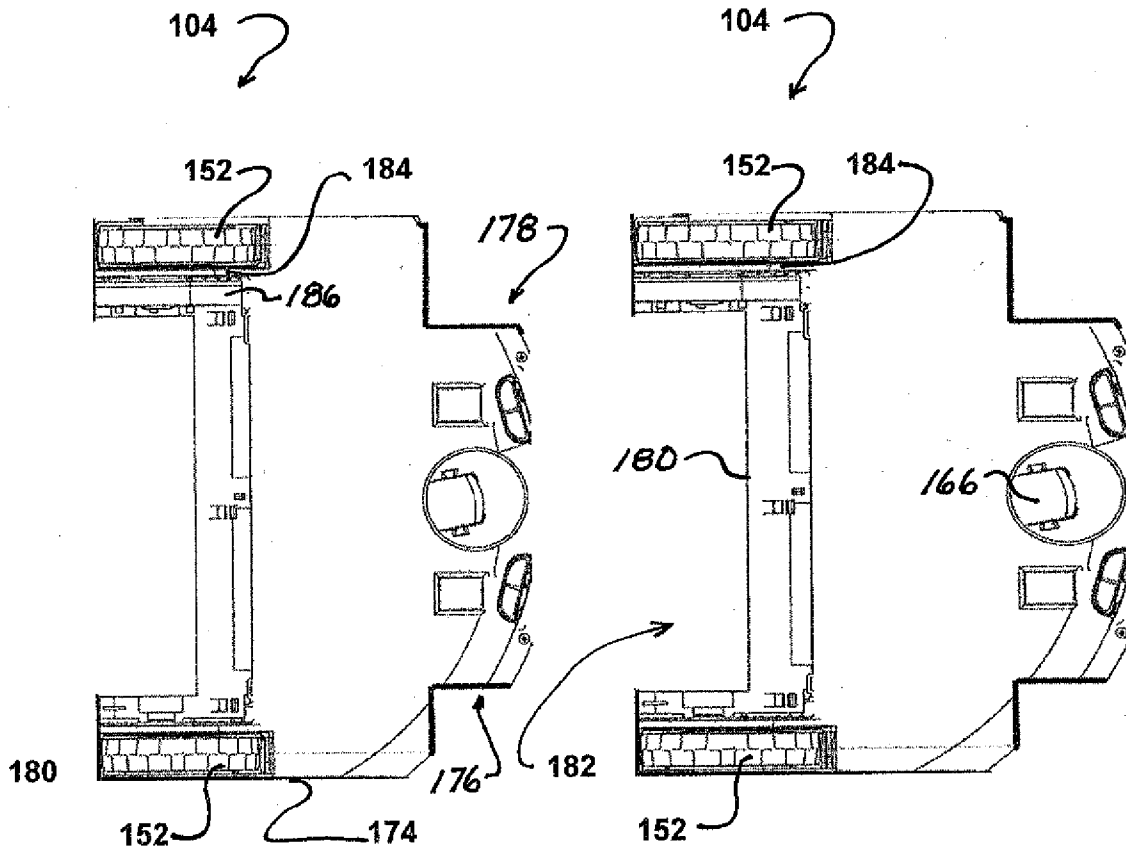

FIG. 15

15/24

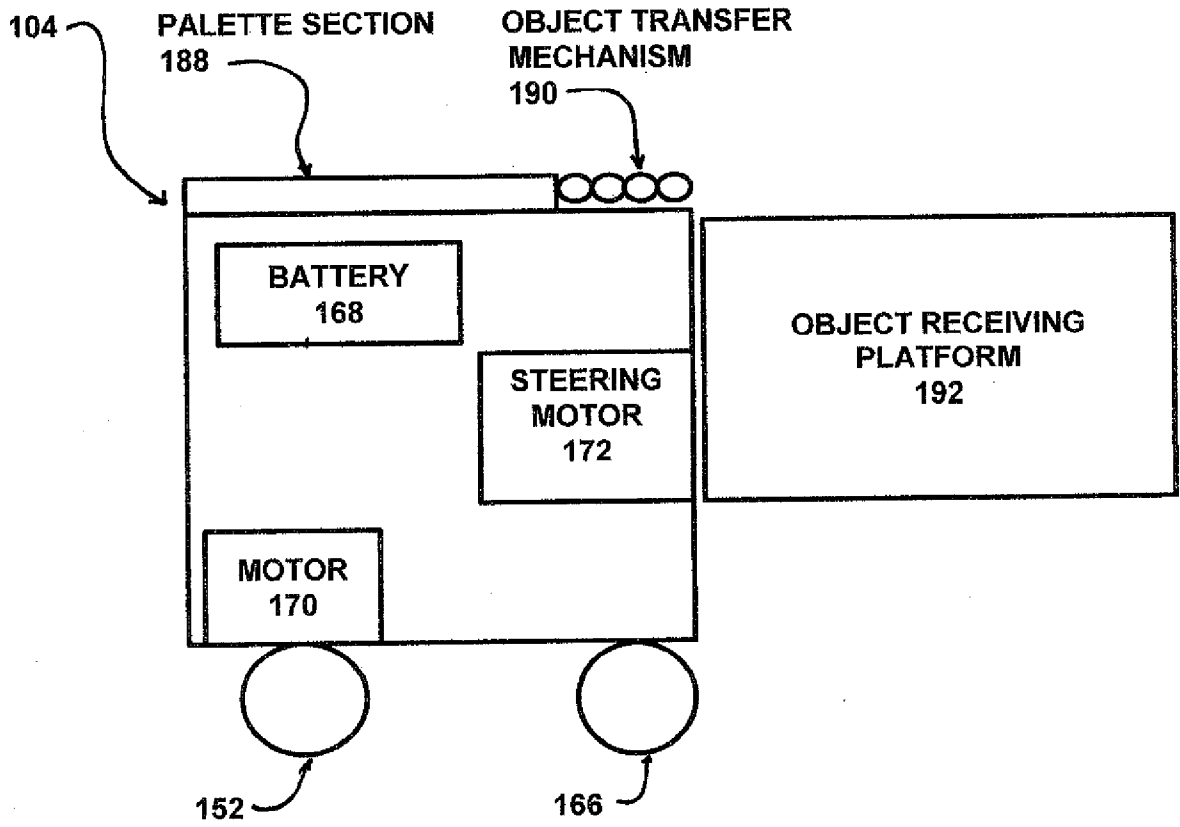

FIG. 16

16/24

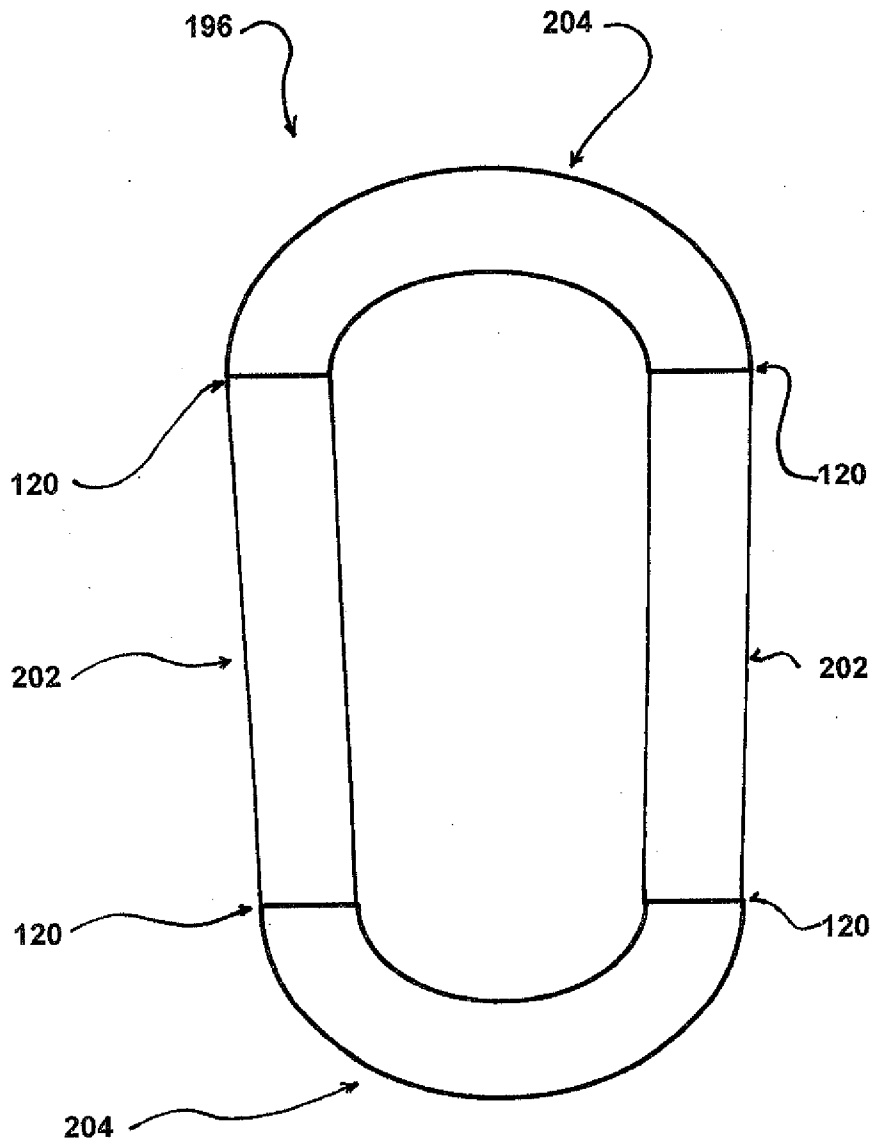

FIG. 17

17/24

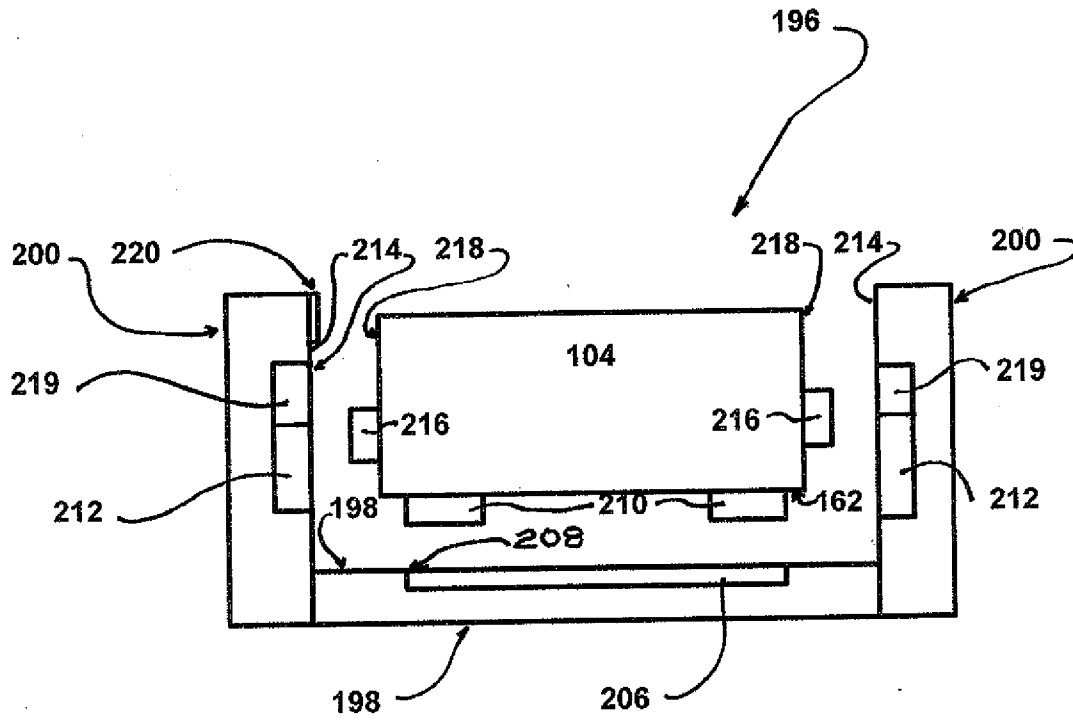

FIG. 18

18/24

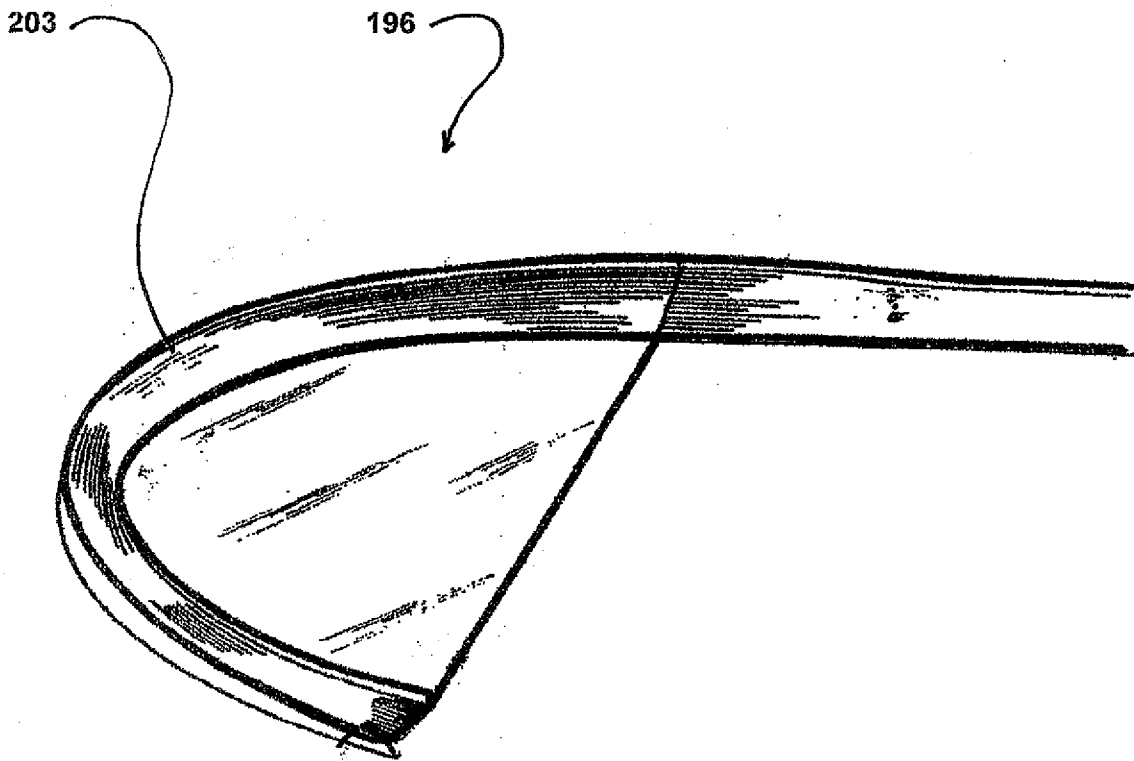

FIG. 19

19/24

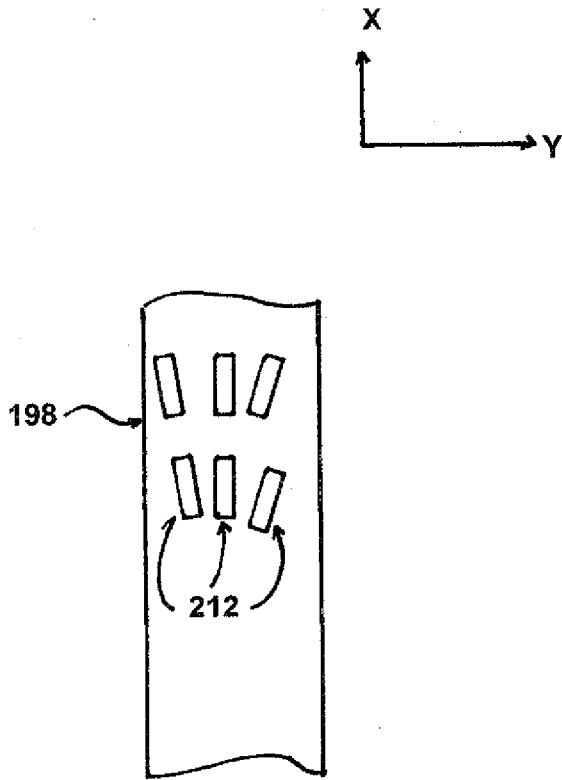

FIG. 20

20/24

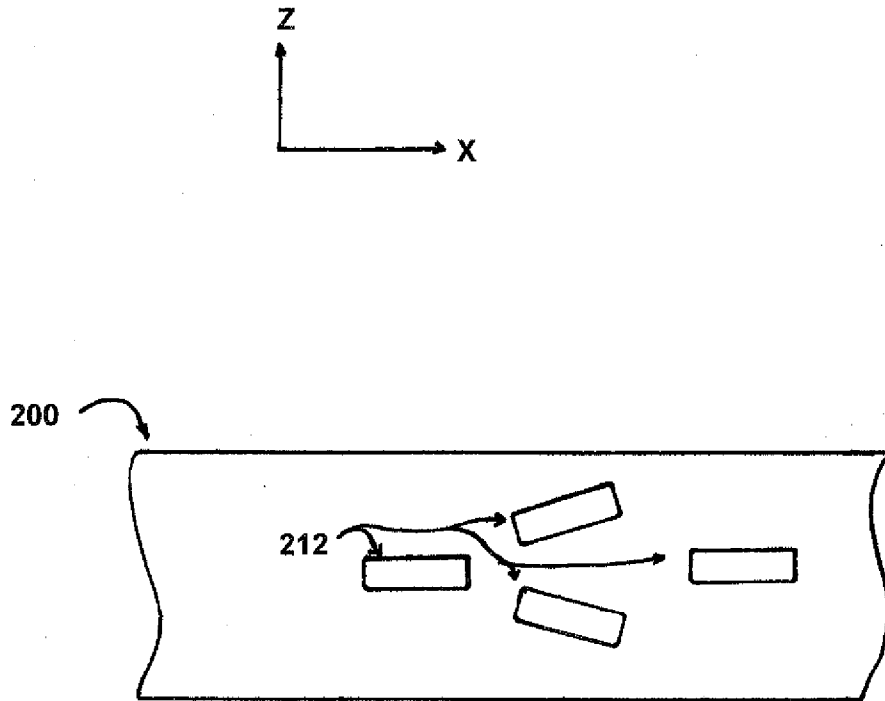

FIG. 21

21/24

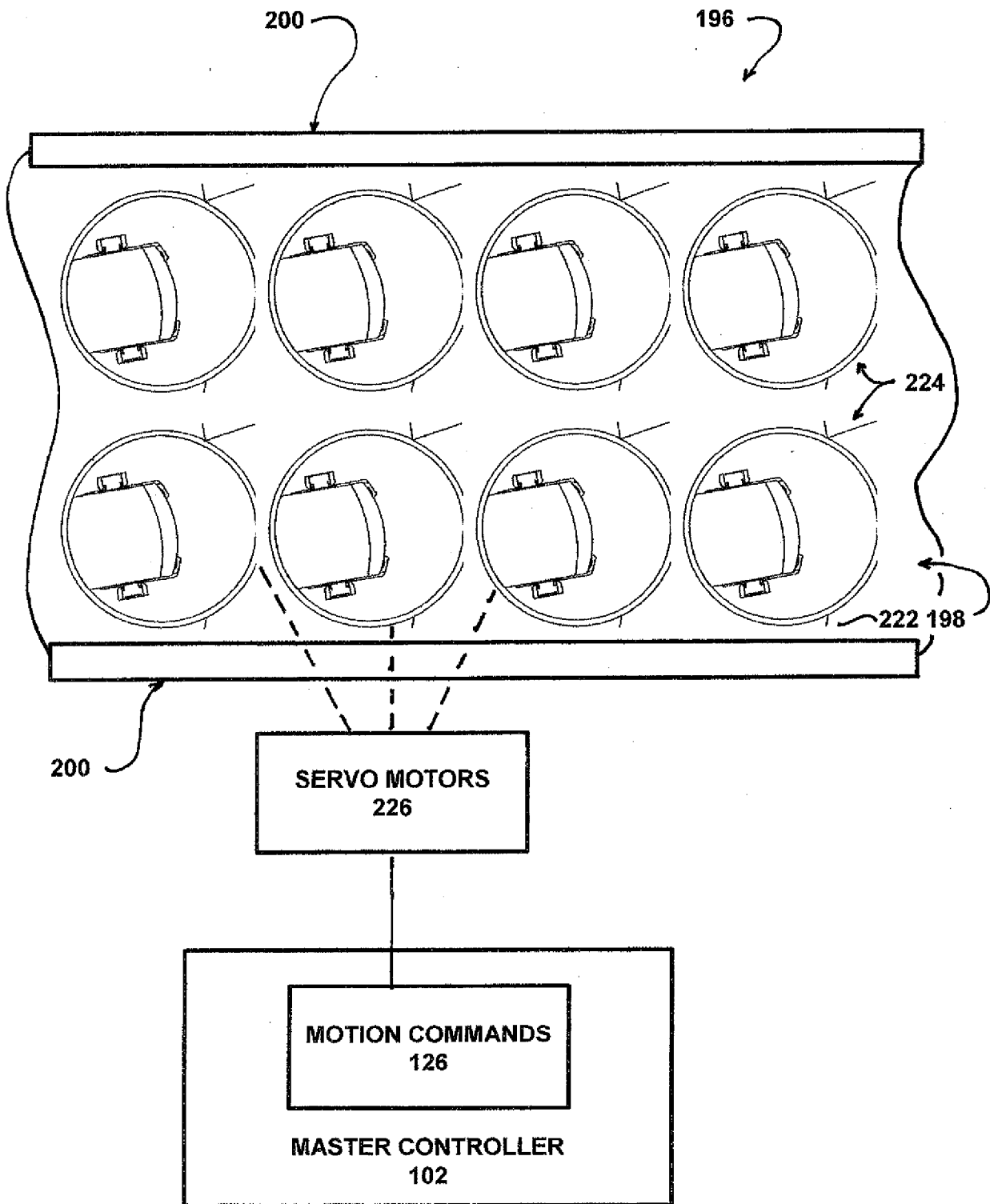

FIG. 22

22/24

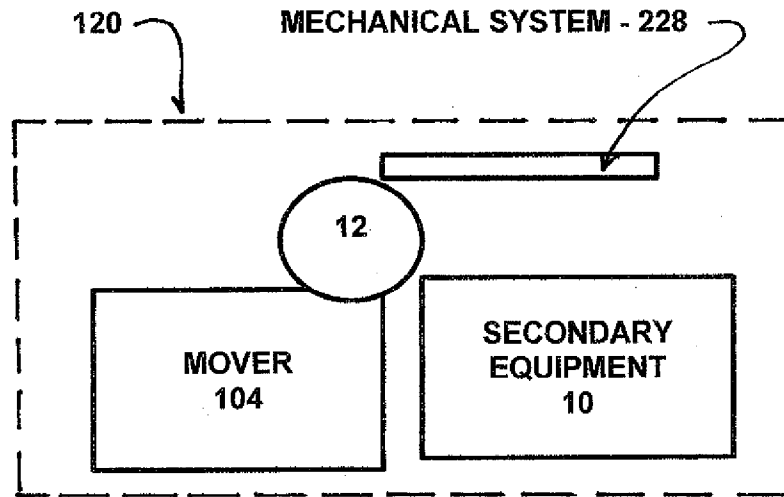

FIG. 23

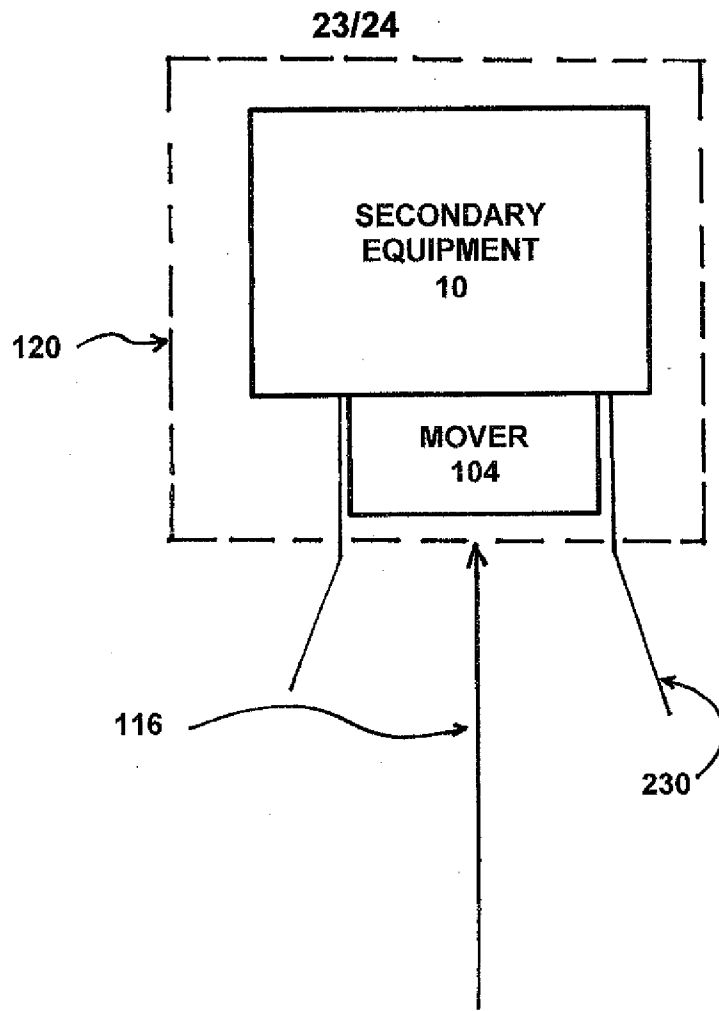
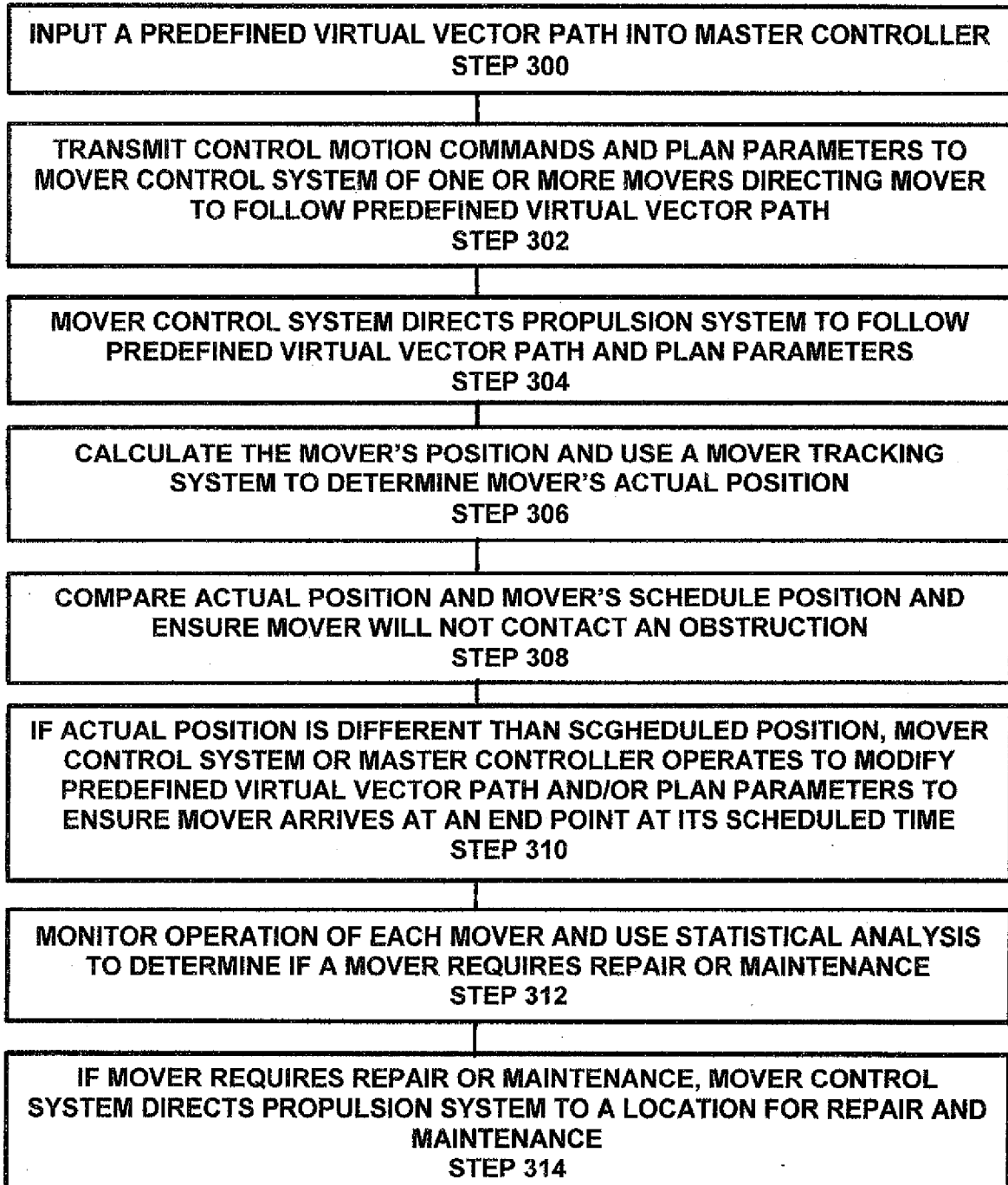

FIG. 24

24/24



INTERNATIONAL SEARCH REPORT

International application No.

PCT/US2017/034445

A. CLASSIFICATION OF SUBJECT MATTER

IPC(8) - B07C 1/02; B61L 27/04; B65H 29/58; G05D 1/02; G06F 7/00 (2017.01)

CPC - B07C 1/16; B61L 27/04; B65H 29/12; B65H 29/6618; B65H 2301/342; B65H 2301/42146; B65H 2301/4474; B65H 2404/2691; B65H 2511/13; B65H 2511/22; B65H 2513/40; B65H 2701/1916; G05D 1/00; G05D 1/0214; G05D 1/0244; G05D 1/0265; G05D 1/0274; G05D 1/028; G05D 1/0285; G05D 2201/0212; G06Q 10/08; G06Q 50/28 (2017.02)

According to International Patent Classification (IPC) or to both national classification and IPC

B. FIELDS SEARCHED

Minimum documentation searched (classification system followed by classification symbols)

See Search History document

Documentation searched other than minimum documentation to the extent that such documents are included in the fields searched

USPC - 246/122.00R; 246/5; 271/279; 455/39; 455/41.200; 700/228; 901/9; 901/47 (keyword delimited)

Electronic data base consulted during the international search (name of data base and, where practicable, search terms used)

See Search History document

C. DOCUMENTS CONSIDERED TO BE RELEVANT

Category*	Citation of document, with indication, where appropriate, of the relevant passages	Relevant to claim No.
X	US 6,810,817 B1 (JAMES) 02 November 2004 (02.11.2004), entire document	1, 4, 10
---		---
Y		2, 3, 5-9, 11-36
Y	US 2013/0116865 A1 (COOPER et al) 09 May 2013 (09.05.2013), entire document	2, 3, 6, 23-36
Y	US 2013/0110281 A1 (JONES et al) 02 May 2013 (02.05.2013), entire document	5-8, 35
Y	US 2012/0055367 A1 (ZAYAS) 08 March 2012 (08.03.2012), entire document	9, 11, 12, 17, 18, 26, 28, 30
Y	US 2013/0304300 A1 (PEAKE et al) 14 November 2013 (14.11.2013), entire document	13, 14
Y	US 2010/0064929 A1 (POST) 18 March 2010 (18.03.2010), entire document	15
Y	US 2012/0239224 A1 (MCCABE et al) 20 September 2012 (20.09.2012), entire document	16, 21, 22
Y	US 2010/0135238 A1 (SADRI et al) 03 June 2010 (03.06.2010), entire document	19, 20
A	US 2007/0135964 A1 (BONHAM et al) 14 June 2007 (14.06.2007), entire document	1-36
A	US 2010/0030375 A1 (HARTMANN et al) 04 February 2010 (04.02.2010), entire document	1-36
A	US 4,974,259 A (TAKAHASHI et al) 27 November 1990 (27.11.1990), entire document	1-36

Further documents are listed in the continuation of Box C. See patent family annex.

* Special categories of cited documents:	"T" later document published after the international filing date or priority date and not in conflict with the application but cited to understand the principle or theory underlying the invention
"A" document defining the general state of the art which is not considered to be of particular relevance	"X" document of particular relevance; the claimed invention cannot be considered novel or cannot be considered to involve an inventive step when the document is taken alone
"E" earlier application or patent but published on or after the international filing date	"Y" document of particular relevance; the claimed invention cannot be considered to involve an inventive step when the document is combined with one or more other such documents, such combination being obvious to a person skilled in the art
"L" document which may throw doubts on priority claim(s) or which is cited to establish the publication date of another citation or other special reason (as specified)	"&" document member of the same patent family
"O" document referring to an oral disclosure, use, exhibition or other means	
"P" document published prior to the international filing date but later than the priority date claimed	

Date of the actual completion of the international search

17 July 2017

Date of mailing of the international search report

02 AUG 2017

Name and mailing address of the ISA/US
Mail Stop PCT, Attn: ISA/US, Commissioner for Patents
P.O. Box 1450, Alexandria, VA 22313-1450
Facsimile No. 571-273-8300

Authorized officer
Blaine R. Copenheaver

PCT Helpdesk: 571-272-4300
PCT OSP: 571-272-7774

INTERNATIONAL SEARCH REPORT

International application No.
PCT/US2017/034445

C (Continuation). DOCUMENTS CONSIDERED TO BE RELEVANT		
Category*	Citation of document, with indication, where appropriate, of the relevant passages	Relevant to claim No.
A	US 2008/0211178 A1 (ZIMMERMANN) 04 September 2008 (04.09.2008), entire document	1-36