



US 20040055214A1

(19) **United States**

(12) **Patent Application Publication**

Weder et al.

(10) **Pub. No.: US 2004/0055214 A1**

(43) **Pub. Date: Mar. 25, 2004**

(54) **DECORATIVE FLORAL ASSEMBLY**

(76) Inventors: **Donald E. Weder**, Highland, IL (US);
William F. Straeter, Breese, IL (US)

Correspondence Address:
DUNLAP, CODDING & ROGERS P.C.
PO BOX 16370
OKLAHOMA CITY, OK 73113 (US)

5,890,343, which is a continuation of application No. 08/463,641, filed on Jun. 5, 1995, now Pat. No. 5,615,532, which is a continuation of application No. 08/427,014, filed on Apr. 24, 1995, now Pat. No. 5,501,059, which is a continuation of application No. 07/941,992, filed on Sep. 8, 1992, now Pat. No. 5,410,856, which is a continuation-in-part of application No. 07/893,586, filed on Jun. 2, 1992, now Pat. No. 5,181,364.

(21) Appl. No.: **10/662,156**

Publication Classification

(22) Filed: **Sep. 12, 2003**

(51) **Int. Cl.⁷** **A01G 9/02**
(52) **U.S. Cl.** **47/72**

Related U.S. Application Data

(63) Continuation of application No. 10/328,089, filed on Dec. 20, 2002, which is a continuation of application No. 10/040,669, filed on Jan. 7, 2002, now Pat. No. 6,513,304, which is a continuation of application No. 09/901,997, filed on Jul. 10, 2001, now Pat. No. 6,345,488, which is a continuation of application No. 09/603,712, filed on Jun. 27, 2000, now Pat. No. 6,269,611, which is a continuation of application No. 09/243,961, filed on Feb. 3, 1999, now Pat. No. 6,101,789, which is a continuation of application No. 08/813,850, filed on Mar. 7, 1997, now Pat. No.

ABSTRACT

(57) A decorative floral assembly comprising a floral holding material, a floral grouping supported by the floral holding material, and a decorative sheet of material. The floral holding material is constructed of a material capable of supporting the floral grouping without a pot. The decorative sheet of material is extended about a portion of the floral holding material and a crimped portion is formed in the decorative sheet of material with the crimped portion cooperating to hold the decorative sheet of material about the floral holding material to provide a decorative covering.

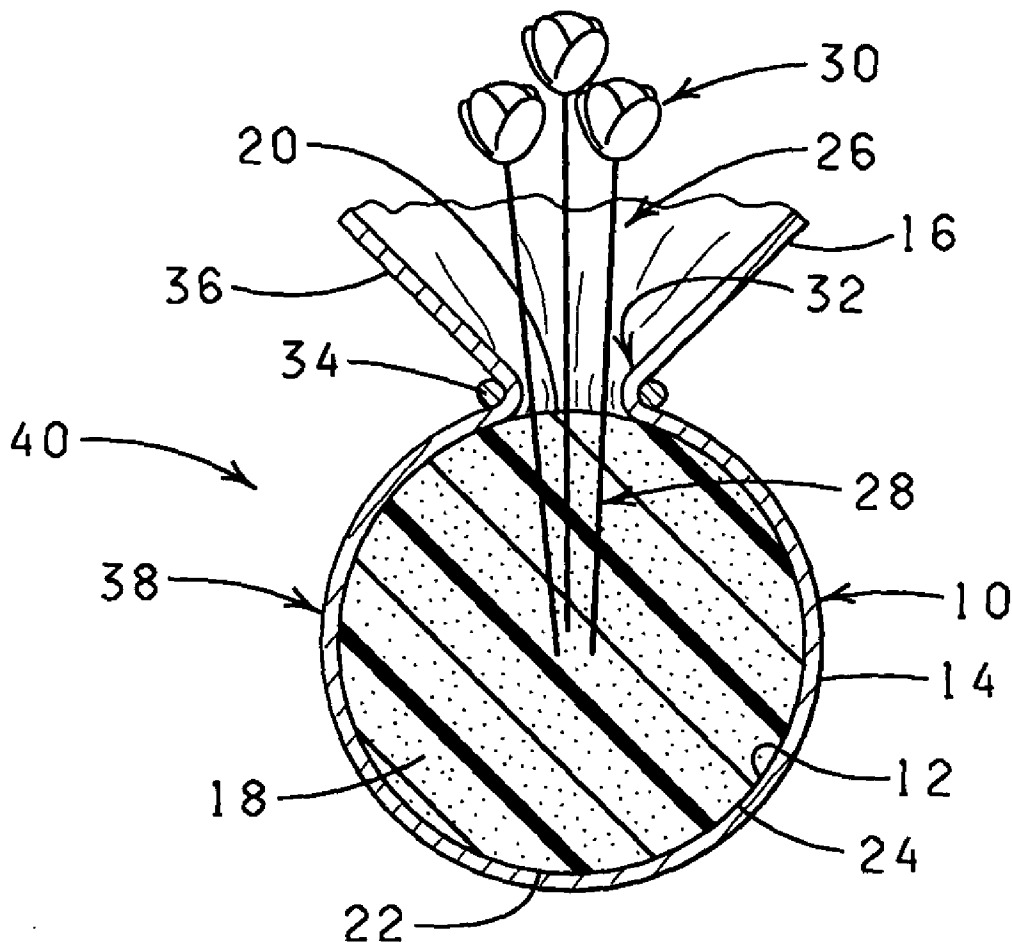

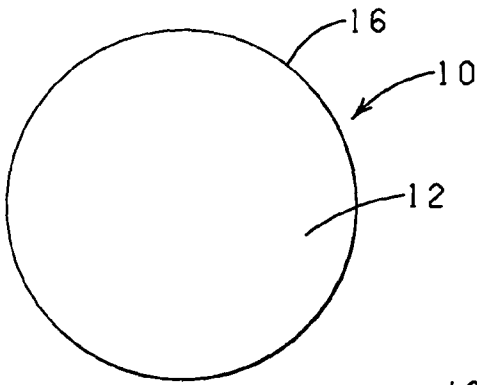

FIG. 1

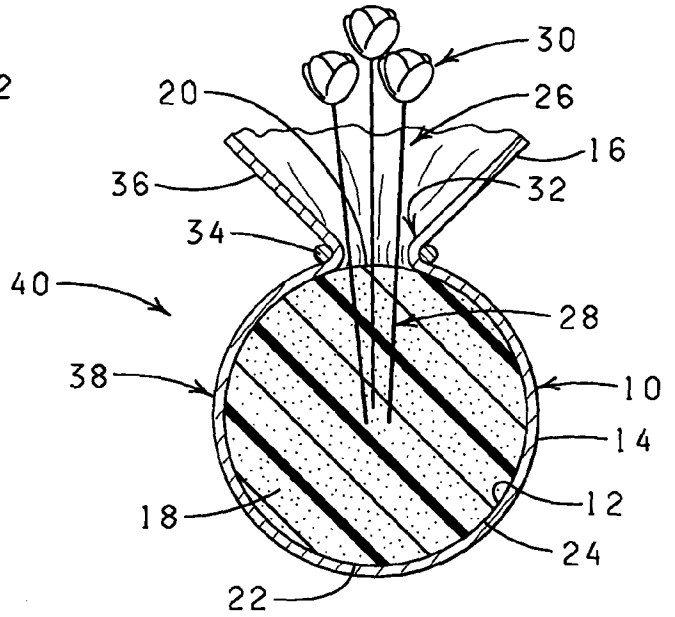

FIG. 2

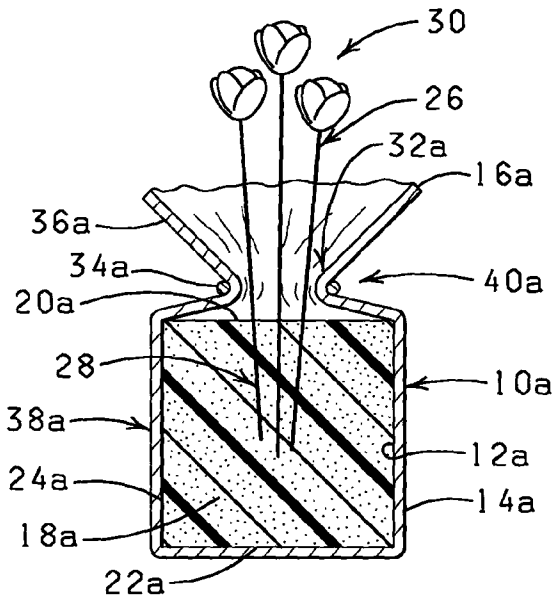

FIG. 3

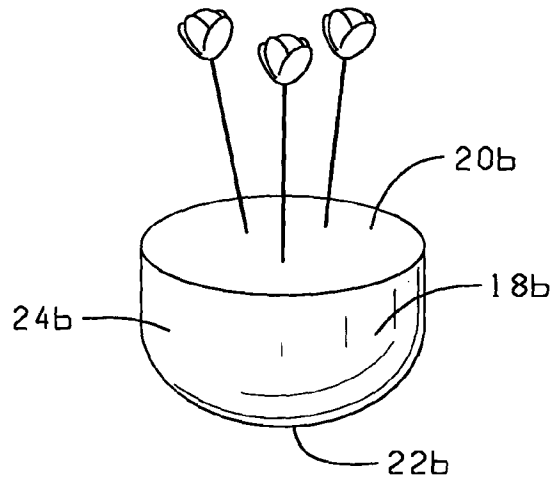

FIG. 4

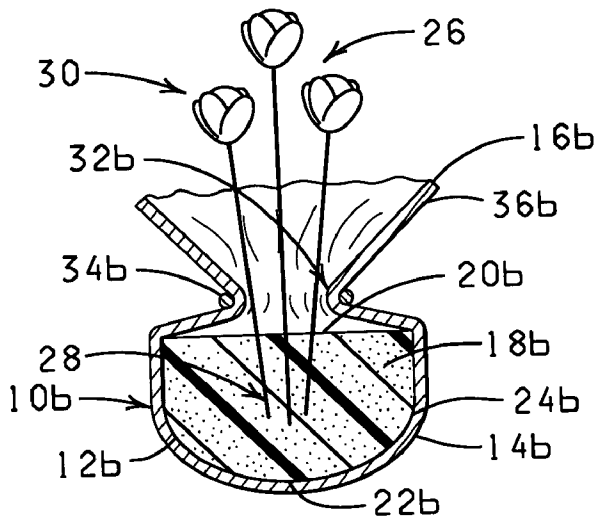

FIG. 5

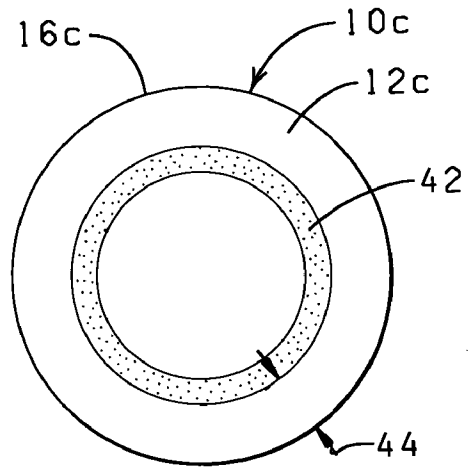

FIG. 6

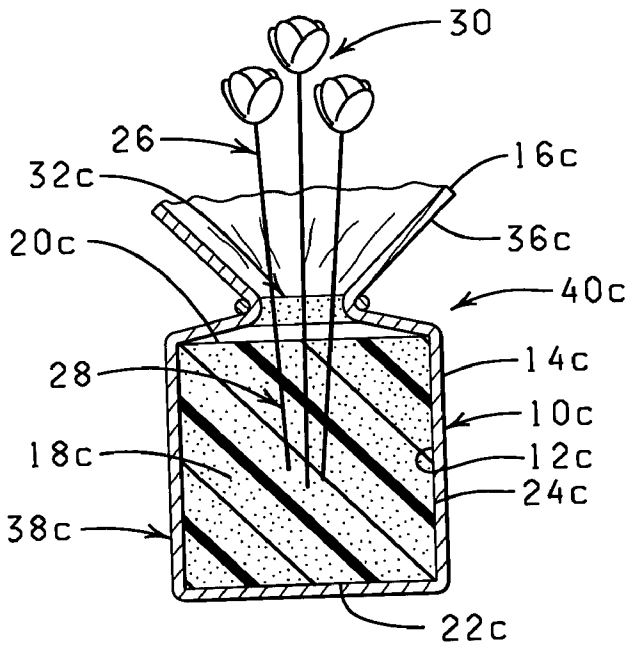
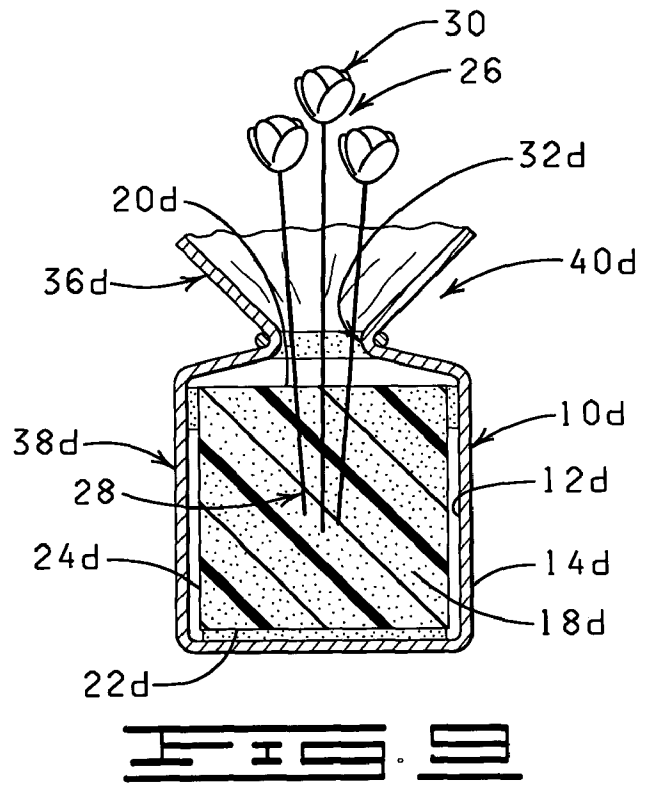
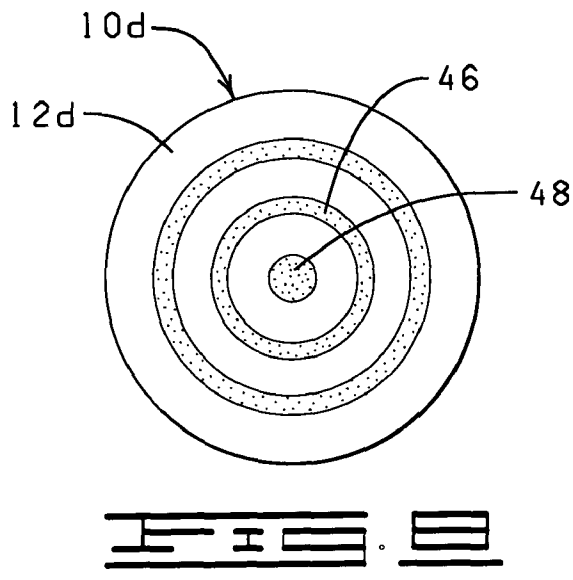

FIG. 7



DECORATIVE FLORAL ASSEMBLY

CROSS REFERENCE TO RELATED APPLICATIONS

[0001] This application is a continuation of U.S. Ser. No. 10/328,089, filed Dec. 28, 2002, which is a continuation of U.S. Ser. No. 10/040,669, filed Jan. 7, 2002, now U.S. Pat. No. 6,513,304, issued Feb. 4, 2003, which is a continuation of U.S. Ser. No. 09/901,997, filed Jul. 10, 2001, now U.S. Pat. No. 6,345,488; which is a continuation of U.S. Ser. No. 09/603,712, filed Jun. 27, 2000, now U.S. Pat. No. 6,269,611, issued Aug. 7, 2001; which is a continuation of U.S. Ser. No. 09/243,961, filed Feb. 3, 1999, now U.S. Pat. No. 6,101,789, issued Aug. 15, 2000; which is a continuation of U.S. Serial No. U.S. Ser. No. 08/813,850, filed Mar. 7, 1997, now U.S. Pat. No. 5,890,343, issued Apr. 6, 1999; which is a continuation of U.S. Ser. No. 08/463,641, filed Jun. 5, 1995, now U.S. Pat. No. 5,615,532, issued Apr. 1, 1997; which is a continuation of U.S. Ser. No. 08/427,014, filed Apr. 24, 1995, now U.S. Pat. No. 5,501,059, issued Mar. 26, 1996; which is a continuation of U.S. Ser. No. 07/941,992, filed Sep. 8, 1992, now U.S. Pat. No. 5,410,856, issued May 2, 1995 which is a continuation-in-part of U.S. Ser. No. 07/893,586, filed Jun. 2, 1992, now U.S. Pat. No. 5,181,364, issued Jan. 26, 1993. Each of the applications listed above is hereby expressly incorporated by reference herein in its entirety.

FIELD OF THE INVENTION

[0002] The present invention relates generally to decorative assemblies for floral groupings and, more particularly, but not by way of limitation, to a decorative assembly for a floral grouping comprising a sheet of material disposed about a floral holding material with a crimped portion formed in the sheet of material for cooperating to hold the sheet of material in position about the floral holding material to provide a decorative covering.

BRIEF DESCRIPTION OF THE DRAWINGS

[0003] FIG. 1 is a plan view of a sheet of material constructed in accordance with the present invention.

[0004] FIG. 2 is a cross-sectional view showing the sheet of material extended about a portion of a floral holding material with a crimped portion being formed in the sheet of material for cooperating to hold the sheet of material in the position extended about the floral grouping to provide a decorative covering in accordance with the present invention.

[0005] FIG. 3 is a cross-sectional view of a modified floral holding material showing the sheet of material of FIG. 1 wrapped about the modified floral holding material to provide a decorative covering.

[0006] FIG. 4 is a perspective view of yet another modified floral holding material.

[0007] FIG. 5 is a cross-sectional view of the modified floral holding material of FIG. 4 showing the sheet of material disposed about a portion of the modified floral holding material with the crimped portion being formed and a portion of the sheet of material.

[0008] FIG. 6 is a plan view of a modified sheet of material.

[0009] FIG. 7 is a cross-sectional view of a floral holding material with the sheet of material of FIG. 6 disposed about a portion of the floral holding material and a modified crimped portion being formed in a portion of the sheet of material.

[0010] FIG. 8 is a plan view of still another modified sheet of material.

[0011] FIG. 9 is a cross-sectional view of a floral holding material showing the sheet of material of FIG. 8 disposed about a portion of the floral holding material with the crimped portion being formed in the sheet of material in a manner like that shown in FIG. 7.

DESCRIPTION OF THE PREFERRED EMBODIMENTS

[0012] Shown in FIG. 1 and designated by the general reference numeral 10 is a sheet of material constructed in accordance with the present invention. The sheet of material 10 has an upper surface 12, a lower surface 14 (not shown) and an outer peripheral edge 16.

[0013] The sheet of material 10 is constructed from any suitable flexible material that is capable of being wrapped or extended about a floral holding material 18 (FIG. 2) in the manner described below. Preferably, the sheet of material 10 is constructed of a material selected from a group of materials consisting of paper, metal foil, cloth (natural or synthetic or combinations thereof), denim, burlap, polymer film or cling material or combinations thereof.

[0014] The term "polymer film" as used herein means any polymer film. For example, but not by way of limitation, one polymer film is a polypropylene film. Another example of a polymer film, but not by way of limitation, is cellophane.

[0015] The sheet of material 10 has a thickness in a range from about 0.1 mil to about 30 mils. Preferably, the sheet of material 10 has a thickness in a range from about 0.1 mil to about 5 mils.

[0016] The sheet of material 10 may be any shape and a circular shape is shown in FIG. 1 only by way of example. The sheet of material 10 for example only may be square or rectangular or any other geometric shape such as heart shaped for example only.

[0017] The sheet of material 10 may be constructed of a single layer of material or a plurality of layers of the same or different types of materials. Any thickness of the sheet of material 10 may be utilized in accordance with the present invention as long as the sheet of material 10 is wrappable about the floral holding material 18, as described herein. Additionally, an insulating material such as bubble film, preferable as one of two or more layers, can be utilized in order to provide additional protection for the item wrapped therein. The layers of material comprising the sheet of material 10 may be connected together or laminated or may be separate layers.

[0018] A decorative pattern, such as a color and/or an embossed pattern, and/or other decorative surface ornamentation may be applied to the upper surface 12 and/or the lower surface 14 of the sheet of material 10 or portions thereof including, but not limited to printed design, coatings, colors, flocking or metallic finishes. The sheet of material 10 also may be totally or partially clear or tinted transparent material.

[0019] “Cling Wrap or Material” as used herein means any material which is capable of connecting to the sheet of material and/or itself upon contacting engagement during the wrapping process and is wrappable about an item whereby portions of the cling material contactingly engage and connect to other portions of the wrapping material for generally securing the sheet of material wrapped about at least a portion of the item. This connecting engagement is preferably temporary in that the wrapping material may be easily removed without tearing same, i.e., the cling material “clings” to the wrapping material. A wrapping material which remains securely connected to and about the wrapped item until the wrapping material is torn therefrom.

[0020] The cling material is constructed and treated if necessary, from polyethylene such as Cling Wrap made by Glad®, First Brands Corporation, Danbury, Conn. The thickness of the cling material will, in part, depend upon the thickness of the sheet of material utilized, i.e., generally, the thicker and therefore heavier sheet of material may require a thicker and therefore stronger cling material. The cling material will range in thickness from less than about 0.2 mil to about 10 mils, and preferably less than about 0.5 mil to about 2.5 mils and most preferably from less than about 0.6 mil to about 2 mils. However, any thickness of cling material may be utilized in accordance with the present invention which permits the cling material to function as described herein.

[0021] As shown in FIG. 2, the floral holding material 18 has an upper end 20, a lower end 22 and an outer peripheral surface 24. The floral holding material 18 shown in FIG. 2 is spherically shaped, although the floral holding material 18 may be any shape desired in any particular application. The floral holding material 18 is constructed of a material capable of receiving a portion of a floral grouping 26 and holding or supporting the floral grouping 26 without any pot such as a separate flower pot for example.

[0022] The floral holding material 18 may be the type of material commonly referred to in the art as floral foam or Oasis™ or may be soil or artificial soil or other earth composition so long as the material is capable of holding its predetermined shape and capable of receiving and supporting the floral grouping 26 without any additional pot. The floral holding material 18 may be capable of receiving and holding water for supplying water to the floral grouping 26.

[0023] As shown in FIG. 2, the floral grouping 26 has a stem end 28 and a bloom end 30. A portion of the stem end 28 of the floral grouping 26 is extended into the floral holding material 18. The bloom end 30 of the floral grouping 26 extends a distance above the floral holding material 18.

[0024] “Floral grouping” as used herein means cut fresh flowers, artificial flowers, a single flower, other fresh and/or artificial plants or other floral materials and may include other secondary plants and/or ornamentation which add to the aesthetics of the overall floral grouping.

[0025] As mentioned before, the floral holding material 18, as shown in FIG. 2, is generally spherically shaped. A flat portion (not shown) may be formed on the lower end 22 of the floral holding material 18 so that the floral holding material 18 may be supported more easily on a flat surface such as on a table (not shown) for example.

[0026] The sheet of material 10 is disposed adjacent the floral holding material 18 with the upper surface 12 of the

sheet of material 10 being disposed adjacent the outer peripheral surface 24 of the floral holding material 18. In this position, as shown in FIG. 2, the sheet of material 10 is extended about and covers a substantial portion of the floral holding material 18 leaving the upper end 20 of the floral holding material 18 substantially uncovered so that the floral grouping 26 extends outwardly from the upper end 20 of the floral holding material 18.

[0027] In this position, a crimped portion 32 is formed in the sheet of material 10 near the upper end 20 of the floral holding material 18. The crimped portion 32 is formed by crimping together portions of the sheet of material 10 to form the crimped portion 32. The crimped portion 32 extends a distance inwardly toward a central portion of the floral holding material 18. The crimped portion 32 preferably extends circumferentially about the upper end 20 of the floral holding material 18, although the crimped portion 32 could be formed only in portions of the sheet of material 10 thereby forming circumferentially spaced apart crimped portions if desired in a particular application.

[0028] As shown in FIG. 2, the crimped portion 32 is formed by placing a band 34 about a portion of the sheet of material 10 with the band 34 gathering or bringing together portions of the sheet of material 10 pulling portions of the sheet of material 10 toward a central portion of the upper end 20 of the floral holding material 18 to form the crimped portion 32 securing the sheet of material 10 in a position about the floral holding material 18 to provide a decorative covering 38.

[0029] The term “band” as used herein means any material which may be secured about an object such as a flower pot, such bands commonly being referred to as elastic bands or rubber bands and also includes any other type of material such as a string or elastic piece of material, non-elastic piece of material, a round piece of material, a flat piece of material, a ribbon, a piece of paper strip, a piece of plastic strip, a piece of wire, a tie wrap or a twist tie or combinations thereof or any other device capable of gathering the sheet of material 10 to removably or substantially permanently form the crimped portion 32 and secure the crimped portion 32 formed in the sheet of material 10. The band 34 also may include a bow if desired in a particular application.

[0030] A portion of the sheet of material 10 near the outer peripheral edge 16 thereof extends a distance above and beyond the crimped portion 32 to form a skirt 36 (FIG. 2) extending circumferentially about the upper end 20 of the floral holding material 18 and circumferentially about the floral grouping 26. The sheet of material 10 secured about the floral holding material 18 in the manner just described provides a decorative covering 38. The sheet of material 10 and the floral holding material 18 together with the means for forming the crimped portion 32 comprise a decorative assembly 40.

[0031] In one preferred embodiment, the band 34 is automatically placed about the sheet of material 10 using any one of a number of commercially available automatic or semi automatic banding machines such as the automatic shaping machine Model No. Power 260 available from Clements Industries, Inc., South Hackensack, N.J., or the machine Model No. Model BMNS Side Bender available from Saxmayer Corporation, Blissfield, Minn. (MN), for example.

[0032] In this last mentioned embodiment, the floral holding material 18 with the sheet of material 10 extended

thereabout is placed in the banding machine and the banding machine is activated to automatically place the band **34** about the sheet of material **10**.

[0033] A system for automatically placing a band about a sheet of material disposed about a flower pot is disclosed in co-pending application entitled "BAND APPLICATOR FOR APPLYING A BAND ABOUT A SHEET OF MATERIAL AND A POT" and assigned to the assignee of the present invention and one disclosure of the letters application specifically is incorporated herein by reference. This system can be utilized for automatically placing the band **34** about the sheet of material **10** in accordance with the present invention.

[0034] In one other embodiment, the sheet of material **10** is placed about the floral holding material **18** and then placed in a holding device of the type disclosed in copending patent application entitled "METHOD AND APPARATUS FOR WRAPPING A FLORAL GROUPING WITH WATER HOLDING AND RELEASING MATERIAL", and assigned to the assignee of the present invention, the disclosure of which specifically hereby is incorporated herein by reference. This device includes a band holder. After the floral holding material **18** with the sheet of material **10** extended thereabout is placed in the holding device, the operator then takes a band from the band holder and pulls it over the holding device and onto the sheet of material **10**.

[0035] Embodiment of **FIG. 3**

[0036] Shown in **FIG. 3** is a modified decorative assembly **40a** comprising a sheet of material **10a** wrapped about a modified floral holding material **18a**. The floral holding material **18a** is constructed exactly like the floral holding material **18** shown in **FIG. 2** and described in detail before, except the floral holding material **18a** has a generally rectangularly shaped cross section as compared to the circular shaped cross section shown in **FIG. 2** with respect to the floral holding material **18**.

[0037] The sheet of material **10a** is constructed exactly like the sheet of material **10** except the sheet of material **10a** may be rectangularly shaped.

[0038] The sheet of material **10a** is extended about the floral holding material **18a** and a crimped portion **32a** is formed in the sheet of material **10a** via a band **34a** in a manner exactly like that described before in connection with the sheet of material **10** and the floral holding material **18** shown in **FIG. 2**.

[0039] Embodiment of **FIGS. 4 and 5**

[0040] Shown in **FIG. 4** is a modified floral holding material **18b** which is constructed exactly like the floral holding material **18** shown in **FIG. 2** and described in detail before, except the floral holding material **18b** is in the shape of a solid basket.

[0041] Shown in **FIG. 5** is a sheet of material **10b** which is constructed exactly like the sheet of material **10** shown in **FIG. 1** and described in detail before, except the sheet of material **10b** is disposed or extended about the floral holding material **18b**. A crimped portion **32b** is formed in the sheet of material **10b** via a band **34b** for cooperating to hold the sheet of material **10b** in position about the floral holding material **18b** to provide a decorative covering **38b**.

[0042] A decorative assembly **40b** is constructed and operates exactly like the decorative assembly **40** shown in **FIGS. 1 and 2** and described in detail before, except the sheet of material **10b** is extended about the floral holding material **18b** having a basket like shape as opposed to a spherical shape or rectangularly shaped cross section like the floral holding material **18** or **18a** shown in **FIGS. 2 and 3** respectively.

[0043] Embodiment of **FIGS. 6 and 7**

[0044] Shown in **FIG. 6** is a modified sheet of material **10c** which is constructed exactly like the sheet of material **10** shown in **FIG. 1** and described in detail before, except the sheet of material **10c** has a closure bonding material **42** disposed thereon. More particularly, the closure bonding material **42** is disposed on a upper surface **12c** of the sheet of material **10c** and the closure bonding material **42** is spaced a distance **44** from an outer peripheral edge **16c** of the sheet of material **10c**. The closure bonding material **42** extends circumferentially about the sheet of material **10c**. The closure bonding material **42** is spaced a distance **44** radially from a central portion of the sheet of material **10c**. It should be noted that, although the closure bonding material **42** is shown in **FIG. 6** in the form of a continuous strip of closure bonding material **42**, the closure bonding material **42** may be in the form of spots or spaced apart strips and the spots or strips may be of any geometric shape desired in a particular application.

[0045] The term "bonding material" as used herein means an adhesive, preferably a pressure sensitive adhesive, or a cohesive. Where the bonding material is a cohesive, a similar cohesive material must be placed on the adjacent surface for bondingly contacting and bondingly engaging with the cohesive material. The term "bonding material" also includes materials which are heat sealable and, in this instance, the adjacent portions of the material must be brought into contact and then heat must be applied to effect the seal. The term "bonding material" as used herein also means a heat sealing lacquer which may be applied to the sheet of material and, in this instance, heat also must be applied to effect the sealing. The term "bonding material" as used herein means any type of material or thing which can be used to effect the bonding or connecting of the two adjacent portions of the material or sheet of material to effect the connection or bonding described herein.

[0046] Shown in **FIG. 7** is a floral holding material **18c** which is constructed exactly like the floral holding material **18a** shown in **FIG. 3** and described in detail before.

[0047] In operation, the sheet of material **10c** is extended about a portion of an outer peripheral surface **24c** of the floral holding material **18c**. The crimped portion **32c** is formed in the sheet of material **10c** by crimping together portions of the sheet of material **10c** near the closure bonding material **42** and forming overlapping portions of the sheet of material **10c** with the overlapping portions being substantially bonded via the closure bonding material **42** to form the crimped portion **32c**. The crimped portion **32c** will cooperate to hold the sheet of material **10c** about the floral holding material **18c** to provide a decorative covering **38c** in a manner exactly like that described before with respect to the crimped portion **32** formed with the band **34** shown in **FIG. 2**, except in this instance the crimped portion **32c** is formed by bringing together and bonding portions of the

sheet of material **10c** via the closure bonding material **42**. The closure bonding material **42** is positioned on the upper surface **12c** of the sheet of material **10c** so that the crimped portion **32c** is positioned above an upper end **20c** of the floral holding material **18c**, shown in **FIG. 7**.

[0048] The crimping of the sheet of material **10c** may be accomplished by hand or with a machine or device.

[0049] Embodiment of **FIGS. 8 and 9**

[0050] Shown in **FIG. 8** is a modified sheet of material **10d** which is constructed exactly like the sheet of material **10c** shown in **FIG. 6**, except the sheet of material **10d** also includes a first pot bonding material **46** which extends circumferentially about a portion of the sheet of material **10d**. The first pot bonding material **46** is spaced a distance from the closure bonding material **42** and spaced a distance from a central portion of the sheet of material **10d**. The sheet of material **10d** also includes a second pot bonding material **48** which is disposed on an upper surface **12d** of the sheet of material **10d** with the second pot bonding material **48** covering a central portion of the sheet of material **10d**.

[0051] Shown in **FIG. 9** is a sectional view of a floral holding material **18d** which is constructed exactly like the floral holding material **18a** shown in **FIG. 3** and described in detail before. The sheet of material **10d** is extended about the floral holding material **18d** and a crimped portion **32d** is formed in the sheet of material **10d** in a manner exactly like that described before in connection with the sheet of material **10c** shown in **FIG. 7**.

[0052] The first pot bonding material **46** is disposed on the sheet of material **10d** and positioned thereon so that, when the sheet of material **10d** is wrapped or extended about the floral holding material **18d**, the first pot bonding material **46** is disposed adjacent a portion of the outer peripheral surface **24d** near the upper end **20d** of the floral holding material **18b**. The portion of the sheet of material **10d** with the first pot bonding material **46** thereon is bondingly connected to an outer peripheral surface **24d** of the floral holding material **18d** for further cooperating to hold the sheet of material **10d** extended about the floral holding material **18d**. In addition, the second pot bonding material **48** is positioned on the sheet of material **10d** so that the second pot bonding material **48** engages a portion of a lower end **22d** of the floral holding material **18d** and bondingly connected thereto for still further cooperating to hold the sheet of material **10d** extended about the floral holding material **18d** to form a decorative covering **38d**.

[0053] The closure bonding material **42** and the first and second pot bonding materials **46** and **48** may be disposed on the upper surface or the lower surface or both of the sheets of material **10** described herein or in any of the other positions described in the copending application entitled "METHOD AND APPARATUS FOR FORMING A DECORATIVE COVER", owned by the Assignee of the present invention, the disclosure of which specifically hereby is incorporated herein by reference.

[0054] The present invention particularly is useful for providing a decorative covering using a sheet of material constructed of a material which is non-shape sustaining. Non-shape sustaining means that the material may be shaped about the form of the floral holding material, but the sheet of material will not hold that shape and will relax back into

substantially the non-formed shape unless held in the formed shape by some means such as the forming of the crimped portion in the sheet of material. By comparison, a shape sustaining sheet of material would be a material such as a metal foil for example which may be formed about the floral holding material and which will substantially maintain the formed shape.

[0055] Changes may be made in the construction and the operation of the various components, elements and assemblies described herein and changes may be made in the steps or the sequence of steps of the methods described herein without departing from the spirit and scope of the invention as defined in the following claims.

1. A floral assembly, comprising:

a floral holding material having an upper end, a lower end and an outer peripheral surface and capable of receiving a portion of a floral grouping and supporting the floral grouping without a pot;

a floral grouping supported by the floral holding material;

a decorative sheet of material having an upper surface, a lower surface and an outer peripheral edge, the decorative sheet of material disposed about at least a portion of the outer peripheral surface of the floral holding material; and

the decorative sheet of material having a crimped portion therein, the crimped portion having a plurality of overlapping folds, and at least one of a band and an adhesive or cohesive bonding material disposed about the decorative sheet of material to hold the crimped portion in a position about the floral holding material to secure the decorative sheet of material about the floral holding material and floral grouping supported by the floral holding material.

2. The decorative floral assembly of claim 1 wherein the decorative sheet of material is constructed of a material selected from a group of materials consisting of paper, metal foil, natural or synthetic cloth, denim, burlap or polymer film or combinations thereof.

3. The decorative floral assembly of claim 1 wherein the decorative sheet of material has a thickness in a range from less than about 0.1 mil to about 30 mils.

4. The decorative floral assembly of claim 1 wherein the decorative sheet of material is constructed of a non-shape sustaining material.

5. The decorative floral assembly of claim 1 wherein the band is selected from the group consisting of elastic bands, rubber bands, string, an elastic piece of material, a non-elastic piece of material, a round piece of material, a flat piece of material, a ribbon, a paper strip, a plastic strip, wire, tie wraps, twist ties, bows, or combinations thereof.

6. A decorative floral assembly, comprising:

a floral holding material having an upper end, a lower end and an outer peripheral surface and capable of receiving a portion of a floral grouping and supporting the floral grouping without a pot;

a floral grouping supported by the floral holding material;

a decorative sheet of material having an upper surface, a lower surface and an outer peripheral edge, the deco-

rative sheet of material disposed about at least a portion of the outer peripheral surface of the floral holding material; and

a band disposed about the decorative sheet of material in a position causing the decorative sheet of material to have a crimped portion therein, the crimped portion having a plurality of overlapping folds therein and the plurality of overlapping folds held by the band disposed about the decorative sheet of material to secure the decorative sheet of material about the floral holding material and the floral grouping supported by the floral holding material.

7. The decorative floral assembly of claim 6 wherein the crimped portion is formed in the decorative sheet of material near the upper end of the floral holding material.

8. The decorative floral assembly of claim 6 wherein the crimped portion is formed in the decorative sheet of material at a position above the upper end of the floral holding material.

9. The decorative floral assembly of claim 6 wherein the decorative sheet of material is constructed of a material selected from a group of materials consisting of paper, metal foil, natural or synthetic cloth, denim, burlap or polymer film or combination thereof.

10. The decorative floral assembly of claim 6 wherein the decorative sheet of material has a thickness in a range from less than about 0.1 mil to about 30 mils.

11. The decorative floral assembly of claim 6 wherein the decorative sheet of material is constructed of a non-shape sustaining material.

12. The decorative floral assembly of claim 6 wherein the band is selected from the group consisting of elastic bands, rubber bands, string, an elastic piece of material, a non-elastic piece of material, a round piece of material, a flat piece of material, a ribbon, a paper strip, a plastic strip, wire, tie wraps, twist ties, bows, or combinations thereof.

13. A decorative floral assembly, comprising:

a floral holding material having an upper end, a lower end and an outer peripheral surface and capable of receiving a portion of a floral grouping and supporting the floral grouping without a pot;

a floral grouping supported by the floral holding material;

a decorative sheet of material having an upper surface, a lower surface and an outer peripheral edge, the decorative sheet of material disposed about at least a portion of the outer peripheral surface of the floral holding material while leaving at least a portion of the upper end of the floral holding material uncovered; and

the decorative sheet of material having a crimped portion therein, with the crimped portion having a plurality of overlapping folds, and at least one of a band or an adhesive or cohesive bonding material disposed about the decorative sheet of material to hold the crimped portion in a position about the floral holding material to secure the decorative sheet of material about the floral holding material and the floral grouping supported by the floral holding material.

14. The decorative floral assembly of claim 13 wherein the crimped portion is formed in the decorative sheet of material near the upper end of the floral holding material.

15. The decorative floral assembly of claim 13 wherein the crimped portion is formed in the decorative sheet of material at a position above the upper end of the floral holding material.

16. The decorative floral assembly of claim 13 wherein the decorative sheet of material is constructed of a material selected from a group of materials consisting of paper, metal foil, natural or synthetic cloth, denim, burlap or polymer film or combinations thereof.

17. The decorative floral assembly of claim 13 wherein the decorative sheet of material has a thickness in a range from less than about 0.1 mil to about 30 mils.

18. The decorative floral assembly of claim 13 wherein the decorative sheet of material is constructed of a non-shape sustaining material.

19. The decorative floral assembly of claim 13 wherein the band is selected from the group consisting of elastic bands, rubber bands, string, an elastic piece of material, a non-elastic piece of material, a round piece of material, a flat piece of material, a ribbon, a paper strip, a plastic strip, wire, tie wraps, twist ties, bows, or combinations thereof.

20. A decorative floral assembly, comprising:

a floral holding material having an upper end, a lower end and an outer peripheral surface and capable of receiving a portion of a floral grouping and supporting the floral grouping without a pot;

a floral grouping supported by the floral holding material;

a decorative sheet of material having an upper surface, a lower surface and an outer peripheral edge, the decorative sheet of material disposed about at least a portion of the outer peripheral surface of the floral holding material while leaving at least a portion of the upper end of the floral holding material uncovered; and

a band disposed about the decorative sheet of material in a position causing the decorative sheet of material to have a crimped portion therein, the crimped portion having a plurality of overlapping folds therein and the plurality of overlapping folds held by the band disposed about the decorative sheet of material, to secure the decorative sheet of material about the floral holding material and the floral grouping supported by the floral holding material.

21. The decorative floral assembly of claim 20 wherein the crimped portion is formed in the decorative sheet of material near the upper end of the floral holding material.

22. The decorative floral assembly of claim 20 wherein the crimped portion is formed in the decorative sheet of material at a position above the upper end of the floral holding material.

23. The decorative floral assembly of claim 20 wherein the decorative sheet of material is constructed of a material selected from a group of materials consisting of paper, metal foil, natural or synthetic cloth, denim, burlap or polymer film or combination thereof.

24. The decorative floral assembly of claim 20 wherein the decorative sheet of material has a thickness in a range from less than about 0.1 mil to about 30 mils.

25. The decorative floral assembly of claim 20 wherein the decorative sheet of material is constructed of a non-shape sustaining material.

26. The decorative floral assembly of claim 20 wherein the band is selected from the group consisting of elastic

bands, rubber bands, string, an elastic piece of material, a non-elastic piece of material, a round piece of material, a flat piece of material, a ribbon, a paper strip, a plastic strip, wire, tie wraps, twist ties, bows, or combinations thereof.

27. A decorative floral assembly, comprising:

a floral holding material having an upper end, a lower end and an outer peripheral surface, the floral holding material being constructed of a material capable of receiving a portion of a floral grouping and supporting the floral grouping without a pot;

a floral grouping supported by the floral holding material;

a decorative sheet of material having an upper surface, a lower surface and an outer peripheral edge, the decorative sheet of material disposed about at least a portion of the outer peripheral surface of the floral holding material while leaving at least a portion of the upper end of the floral holding material uncovered; and

a band disposed about the decorative sheet of material in a position causing the decorative sheet of material to

engage the floral holding material for securing the decorative sheet of material in a position extended about the floral holding material to provide a decorative covering.

28. The decorative floral assembly of claim 27 wherein the decorative sheet of material is constructed of a material selected from a group of materials consisting of a material selected from a group of materials consisting of paper, metal foil, natural or synthetic cloth, denim burlap or polymer film or combinations thereof.

29. The decorative floral assembly of claim 27 wherein the decorative sheet of material has a thickness in a range from less than about 0.1 mil to about 30 mil.

30. The decorative floral assembly of claim 27 wherein the step of providing the decorative sheet of material further comprises providing the decorative sheet of material constructed of a non-shape sustaining material.

* * * * *