

(12) UK Patent Application (19) GB (11) 2 305 942 (13) A

(43) Date of A Publication 23.04.1997

(21) Application No 9520538.1

(22) Date of Filing 07.10.1995

(71) Applicant(s)
Chin-San You
No.6, Lane 477, Sec 2, Feng-Shyn Rd, Feng Yuan City,
Taichung Hsien, Taiwan

(72) Inventor(s)
Chin-San You

(74) Agent and/or Address for Service
A R Davies & Co
27 Imperial Square, CHELTENHAM, Gloucestershire,
GL50 1RQ, United Kingdom

(51) INT CL⁶
D04C 1/06

(52) UK CL (Edition O)
D1K K14

(56) Documents Cited
GB 2103667 A GB 1261491 A GB 0401772 A
EP 0134864 A EP 0113196 A WO 92/06235 A

(58) Field of Search
UK CL (Edition N) D1K K14 K246 K381
INT CL⁶ D03D , D04C

(54) Fabric structure formed of a plurality of strands interlaced multidirectionally

(57) A fabric structure 10 is made from at least a first fiber strand 11, a second fiber strand 12 and third fiber strands 13. The strands 11, 12, 13 are interlaced, the strand 11 extending spirally along an imaginary axis 14. The strand 12 extends spirally such that strand 12 and strand 11 form therebetween a predetermined angle, and are interlaced to form a tubular network having axis 14. The strands 13 are interlaced with strands 11, 12 such that each strand 13 is parallel to the axis of the tubular network, and such that strands 13 are united with the tubular network by passing through a predetermined number of network meshes 15.

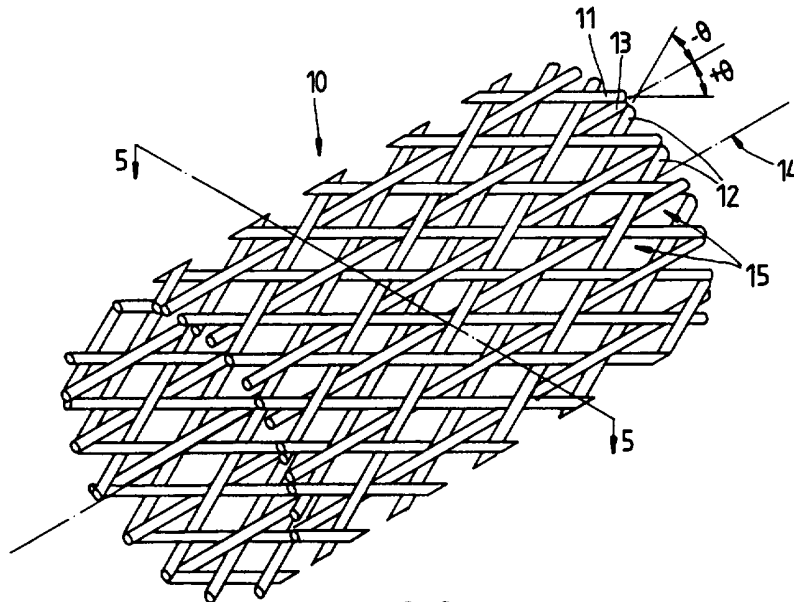

FIG. 3

GB 2 305 942 A

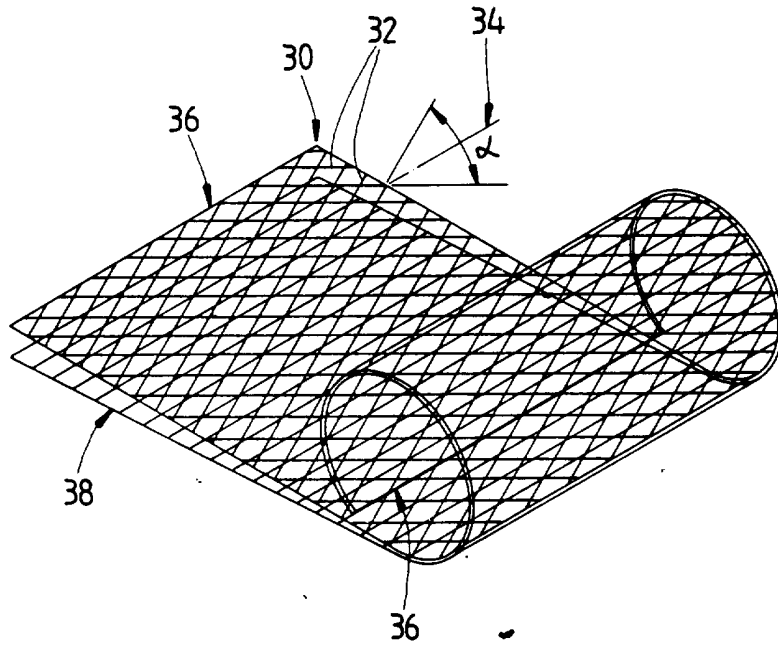

FIG. 1
PRIOR ART

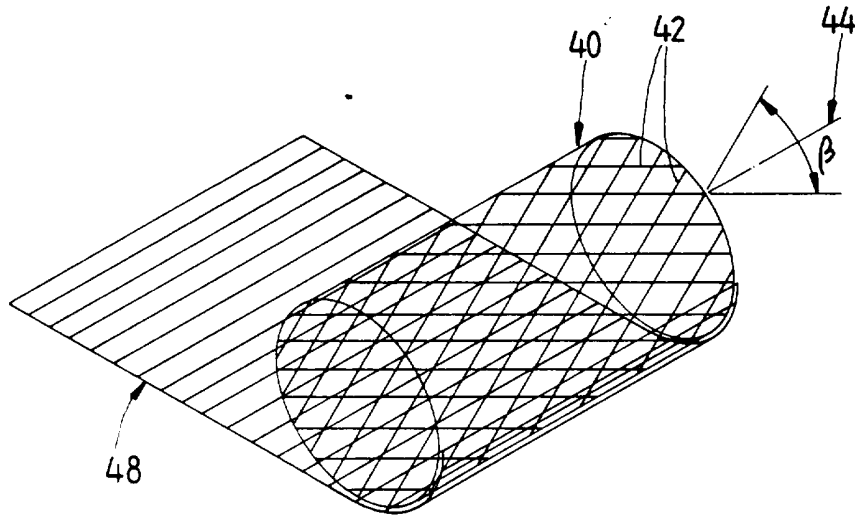

FIG. 2
PRIOR ART

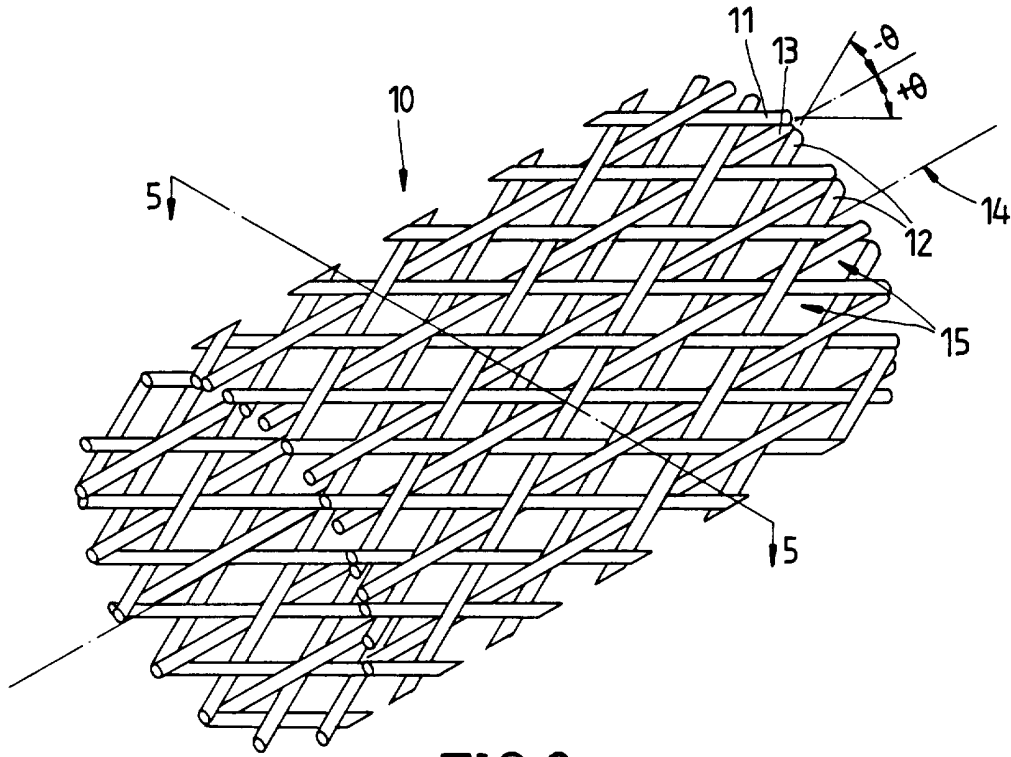

FIG. 3

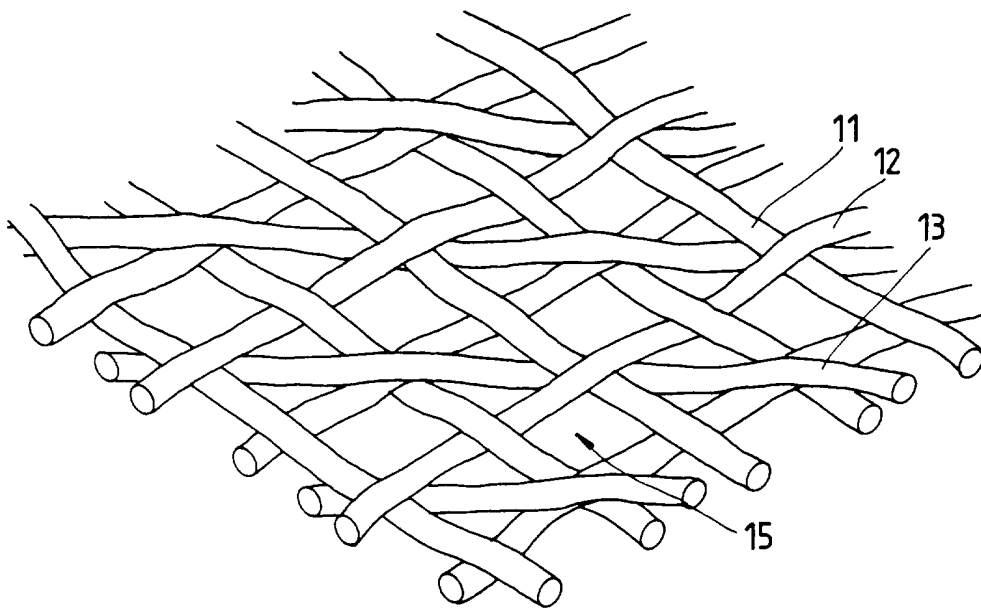

FIG. 4

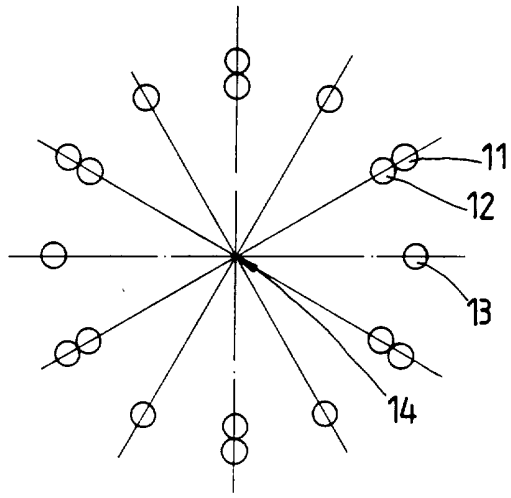

FIG. 5

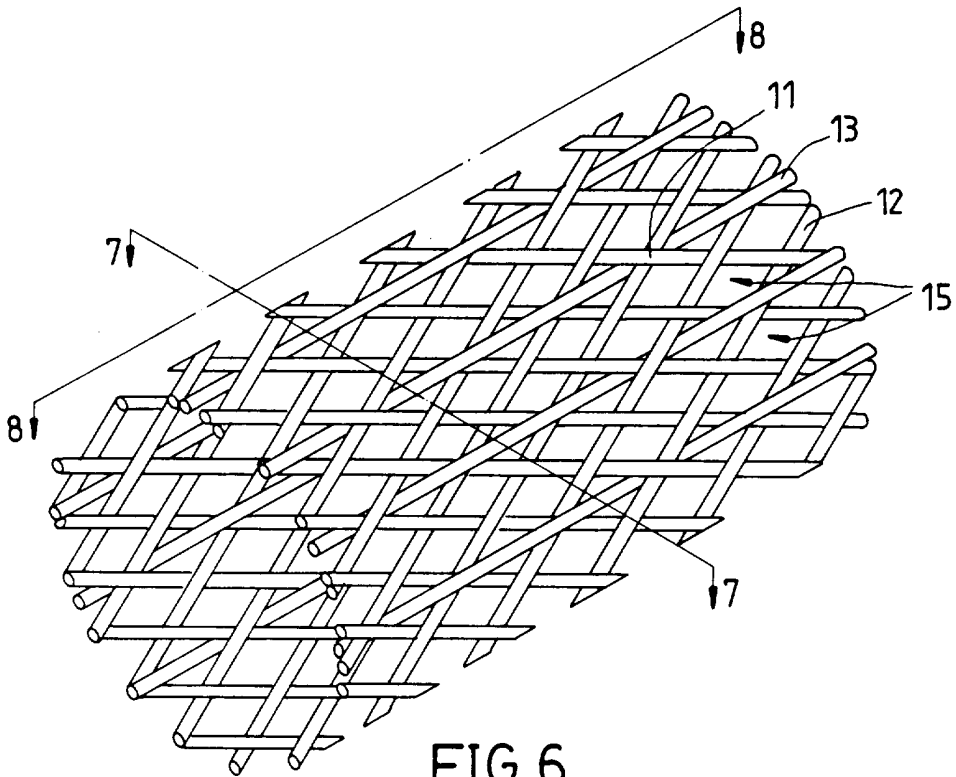

FIG. 6

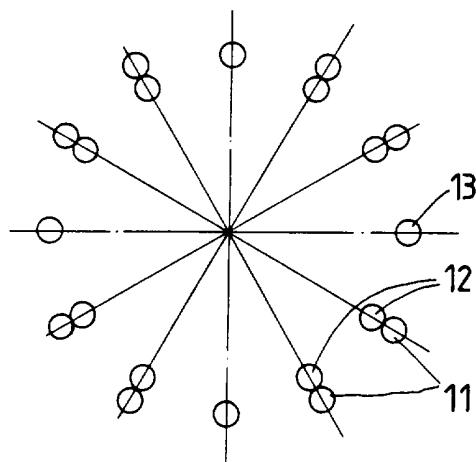

FIG. 7

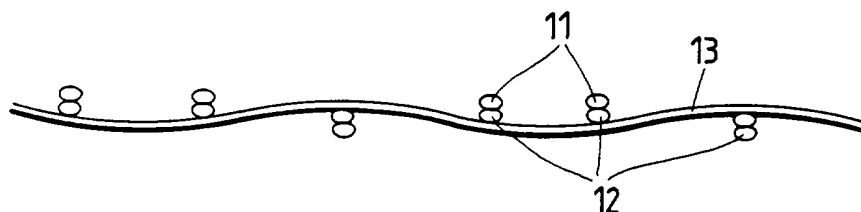

FIG. 8

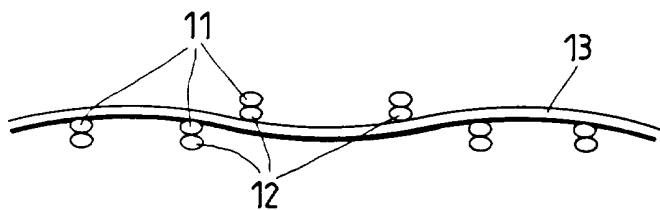

FIG. 9

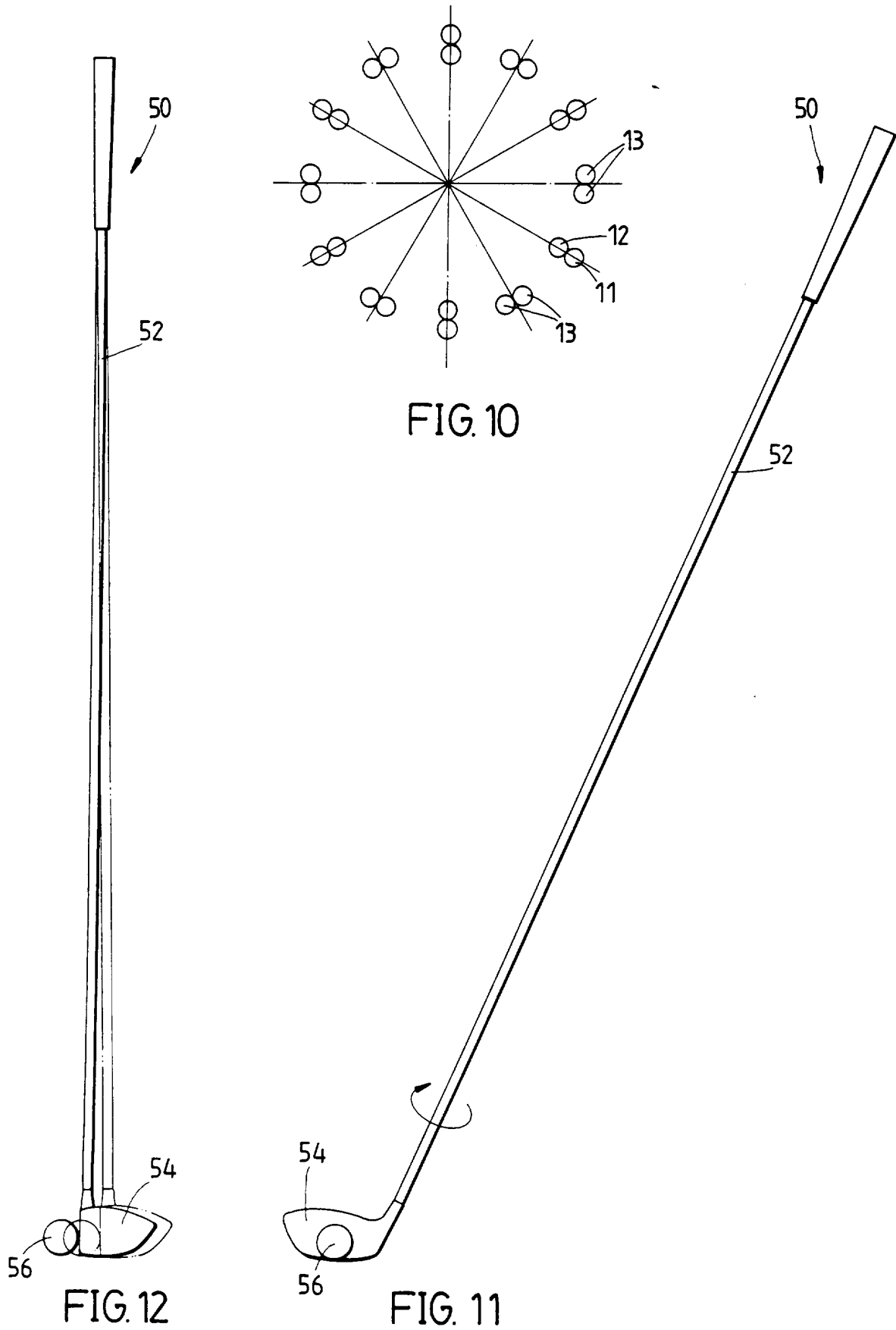

FIG. 10

FIG. 12

FIG. 11

**FIBER FABRIC MATERIAL FORMED OF A PLURALITY OF
FIBER BRAIDS INTERLACED MULTIDIRECTIONALLY**

FIELD OF THE INVENTION

The present invention relates generally to a reinforced fiber fabric material, and more particularly to a reinforced fiber fabric material which is made of a plurality of fiber braids interlaced multidirectionally and is suitable for use in making a tubular article.

BACKGROUND OF THE INVENTION

The fiber fabric materials, such as quartz fiber fabric material, carbon fiber fabric material, glass fiber fabric material, etc., are commonly used in making tubular components of bicycles, golf clubs, hockey sticks, billiard cues, fishing rods, tennis rackets, squash rackets, badminton rackets and so forth.

As illustrated in FIG. 1, a prior art fiber fabric material 30 is made of two sets of fiber braids 32. Each of two sets is composed of a number

of fiber braids 32 which are arranged at intervals and are parallel to one another. Two sets of fiber braids are different in direction in which they extend to form therebetween an angle α . Before the fiber fabric material 30 is used to make a tubular article, the fiber fabric material 30 is impregnated with resin to form a platelike material and is then rolled manually in a direction parallel to a dividing line 34 which divides the angle α into two equal parts. The tubular material so formed is then heated under pressure to take form in a molding tool.

Both ends 36 of the fiber fabric material 30 are weaker in structural strength than other parts of the fiber material 30. For this reason, the fiber material 30 having a greater width is often used to compensate the structural weakness caused by both ends 36 of the fiber fabric material 30. However, there are disadvantages in using a wider fiber fabric material 30 to make a tubular article. Such disadvantages are described hereinafter.

The tubular article made of the wider fiber fabric material 30 is not uniform in structural strength. In other words, the tubular article has a wall which is uneven in thickness in view of the fact that fiber braids 32 of both ends 36 of the fiber fabric material 30 are overlapped to form a thicker wall. In addition, the overlapping of the fiber braids 32 of both ends 36 of the fiber fabric material 30 undermines the esthetic effect of the tubular article made of such fiber fabric material 30. Moreover, the overlapping of the fiber braids 32 of both ends 36 of the fiber fabric material 30 is responsible for an increase in the material cost.

Another prior art fiber fabric material 40 is shown in FIG. 2. The fiber fabric material 40 is made of two sets of fiber braids 42 which are

interlaced such that they form therebetween an angle β . The tubular structure so formed of the fiber fabric material 40 has an axis parallel to a dividing line 44 which divides the angle β into two equal parts. The fiber fabric material 40 is intended to overcome the shortcomings of the prior art fiber fabric material 30 illustrated in FIG. 1.

In view of the fact that the tubular articles made of the fiber fabric materials 30 and 40 are provided with an inadequate flexure strength, the fiber fabric materials 30 and 40 are therefore provided respectively with reinforcing layers 38 and 48, as shown in FIGS. 1 and 2. The reinforcing layers 38 and 48 are provided such that the fiber braids 32 and 42 of the reinforcing layers 38 and 48 are arranged respectively in a direction parallel to the longitudinal axes of the fiber fabric materials 30 and 40 forming the tubular articles.

The addition of the reinforcing layer 38 or 48 is not effective in overcoming the shortcomings of the fiber fabric material 30 or 40. This is due to the fact that the reinforcing layer 38 or 48 is joined with the fiber fabric material 30 or 40 only after the fiber fabric material 30 or 40 is rolled to have a tubular shape. It is therefore readily apparent that the addition of the reinforcing layer is not cost-effective, and that the addition of the reinforcing layer undermines the esthetic effect of the tubular article so made.

SUMMARY OF THE INVENTION

It is therefore the primary objective of the present invention to provide a fiber fabric material capable of overcoming the shortcomings of the prior art fiber materials described above.

In keeping with the principle of the present invention, the foregoing objective of the present invention is attained by a fiber fabric material which is made of at least a first fiber braid, a second fiber braid and a third fiber braid. The fiber braids are interlaced such that the first fiber braid is extended spirally along an imaginary axis. The second fiber braid is extended spirally such that the second fiber braid and the first fiber braid form therebetween a predetermined angle, and that the second fiber braid is interlaced with the first fiber braid to form a tubular network. The third fiber braid is interlaced with the first fiber braid and the second fiber braid such that the third fiber braid is parallel to the axis of the tubular network, and that the third fiber braid is united with the tubular network by passing through a predetermined number of meshes of the tubular network.

BRIEF DESCRIPTION OF THE DRAWINGS

FIG. 1 shows a perspective schematic view of a prior art fiber fabric material.

FIG. 2 shows a perspective schematic view of another prior art fiber fabric material.

FIG. 3 shows a perspective schematic view of a first preferred embodiment of the present invention.

FIG. 4 shows a partial enlarged view of the first preferred embodiment of the present invention.

FIG. 5 shows a sectional view of a portion taken along the direction indicated by a line 5-5 as shown in FIG. 3.

FIG. 6 shows a perspective schematic view of a second preferred embodiment of the present invention.

FIG. 7 shows a sectional view of a portion taken along the direction indicated by a line 7-7 as shown in FIG. 6.

FIG 8 is a sectional schematic view of a portion taken along the direction indicated by a line 8-8 as shown in FIG. 6 for showing the way by which the third fiber braid is arranged.

FIG. 9 is a sectional schematic view taken along the direction of the longitudinal axis of a third preferred embodiment of the present invention for showing the way by which the third fiber braid is arranged.

FIG. 10 is a sectional view taken at right angle to the longitudinal axis of a fourth preferred embodiment of the present invention.

FIG. 11 is a side view illustrating the ball-striking action of a golf club made of the fiber fabric material of the present invention.

FIG. 12 is a front view illustrating the ball-striking action of a golf club made of the fiber fabric material of the present invention.

DETAILED DESCRIPTION OF THE INVENTION

As shown in FIGS. 3-5, a fiber fabric material 10 of the first preferred embodiment of the present invention is composed of a number of first fiber braids 11, second fiber braids 12 and third fiber braids 13, which are interlaced multidirectionally.

The first fiber braids 11 are arranged at a predetermined interval, with each of the first fiber braids 11 being extended spirally to form a first spiral angle $+\theta$ with an imaginary axis 14.

The second fiber braids 12 are arranged at a predetermined interval such that the second fiber braids 12 are extended respectively and spirally to form a second spiral angle $-\theta$ with the imaginary axis 14. The second fiber braids 12 and the first fiber braids 11 are interlaced to form a tubular network having a number of meshes 15.

The third fiber braids 13 are united with the tubular network such that the third fiber braids 13 are parallel to the imaginary axis 14, and that the longitudinal axis of each of the third fiber braids 13 is corresponding in location to a line which divides the sum of the first spiral angle $+\theta$ and the second spiral angle $-\theta$ into two equal parts, and further that the third fiber braids 13 pass through the meshes 15 which

are arranged along the direction of the longitudinal axis of the tubular network.

It is therefore readily apparent that the fiber fabric material 10 of the present invention is relatively cost-effective in view of the fact that the fiber fabric material 10 is devoid of a reinforcing layer which can complicate the process of making a tubular article. In addition, the tubular article made of the fiber fabric material 10 of the present invention is provided with a wall that is uniform in thickness and flexure strength. Moreover, the tubular article made of the fiber fabric material 10 of the present invention is esthetically superior to the tubular article made of the prior art fiber fabric materials. A technical advantage of the fiber fabric material 10 of the present invention must be emphasized here. The flexure strength of the fiber fabric material 10 of the present invention can be easily enhanced by increasing the number of the third fiber braids 13 and by passing each of the third fiber braids 13 through each of the meshes 15. In other words, the third fiber braids 13 can be interlaced with the first fiber braids 11 and the second fiber braids 12 such that the third fiber braids 13 bypass some of the meshes 15.

As shown in FIGS. 6-8, the fiber fabric material of the second preferred embodiment of the present invention is different from the fiber fabric material of the first preferred embodiment of the present invention in that the former is provided with a number of third fiber braids 13 which are interlaced with the first and the second fiber braids 11 and 12 in such a manner that two adjoining third fiber braids 13 are separated by two meshes 15 and that the third fiber braids 13 bypass two meshes 15 before passing through one mesh 15.

As shown in FIG. 9, the fiber fabric material of the third preferred embodiment of the present invention is composed of a number of the third fiber braids 13 which are interlaced with the first and the second fiber braids 11 and 12 in such a manner that the third fiber braids 13 bypass two meshes 15.

As illustrated in FIG. 10, the fiber fabric material of the fourth preferred embodiment of the present invention consists of a number of third fiber braids 13 which are interlaced with the first and the second fiber braids 11 and 12 in such a manner that two of the third fiber braids 13 are put side by side through the same mesh 15.

The relationship between the torsion strength and the flexure strength of a golf club 50 made from the fiber fabric material 10 of the present invention is illustrated in FIGS. 11 and 12. The golf club 50 has a shaft 52 and a head which is fastened with the shaft 52 and is provided with a ball-striking portion 54. When the shaft 52 is swung such that the ball-striking portion 54 hits a golf ball 56, the ball-striking portion 54 is exerted on by a reaction force of the golf ball 56. As a result, a torsional moment indicated by an arrow in FIG. 11 is brought about on the shaft 52. The first and the second fiber braids 11 and 12 of the fiber fabric material 10 serve to prevent the shaft 52 from breaking. In the meantime, the ball-striking portion 54 brings about a flexure moment of force on the shaft 52 by means of the top end of the golf club 50 serving as a fulcrum. The third fiber braids 13 of the fiber fabric material 10 serve to prevent the shaft 52 from breaking. In other words, the structural strength of the golf club 50 is effectively enhanced by the third fiber braids 13 of the fiber fabric material 10 from which the golf club 50 is made.

CLAIMS

1. A fiber fabric material, which comprises:

at least a first fiber braid extending spirally along an imaginary axis such that said first fiber braid form a predetermined angle with said imaginary axis;

at least a second fiber braid extending spirally and coaxially with said first fiber braid such that said second fiber braid and said first fiber braid form a tubular network, with said imaginary axis serving as an axis of said tubular network; and

at least a third fiber braid which is united with said tubular network such that said third fiber braid is extended in a direction parallel to said axis of said tubular network, and that said third fiber braid is put through a predetermined number of meshes of said tubular network.

2. The fiber fabric material as defined in claim 1, wherein said tubular network is united with two or more said third fiber braids which are interlaced with said first fiber braid and said second fiber braid such that said third fiber braids are arranged similarly on both sides of said axis of said tubular network.

3. The fiber fabric material as defined in claim 1, wherein said third fiber braid is interlaced with said first fiber braid and said second fiber braid such that said third fiber braid is caused to bypass a predetermined number of said meshes before said third fiber braid is put through one of said meshes of said tubular network.

4. A fibre fabric material substantially as hereinbefore described with reference to any of Figures 3 to 12 of the accompanying drawings.

Relevant Technical Fields

(i) UK Cl (Ed.N) D1K: K14, K381, K246

(ii) Int Cl (Ed.6) D03D, D04C

Databases (see below)

(i) UK Patent Office collections of GB, EP, WO and US patent specifications.

(ii)

Search Examiner
 MR G WERRETT

Date of completion of Search
 24 NOVEMBER 1995

Documents considered relevant following a search in respect of Claims :-
 1 TO 4

Categories of documents

- | | |
|--|---|
| <p>X: Document indicating lack of novelty or of inventive step.</p> <p>Y: Document indicating lack of inventive step if combined with one or more other documents of the same category.</p> <p>A: Document indicating technological background and/or state of the art.</p> | <p>P: Document published on or after the declared priority date but before the filing date of the present application.</p> <p>E: Patent document published on or after, but with priority date earlier than, the filing date of the present application.</p> <p>&: Member of the same patent family; corresponding document.</p> |
|--|---|

Category	Identity of document and relevant passages	Relevant to claim(s)
X	GB 2103667 A (COM. FRANCE DES ISOCANTS) whole document	1, 2
X	GB 1261491 (AKT. TUDOR) whole document	1, 2
X	GB 0401772 (LONDON) whole document	1, 2
X	EP 0134864 A2 (PLUMMER) see eg Figure 2	1, 2
X	EP 0113196 A1 (CAMBRIDGE) see eg Figure 4	1, 2
X	WO 92/06235 (BENTLEY-HARRIS) whole document	

Databases: The UK Patent Office database comprises classified collections of GB, EP, WO and US patent specifications as outlined periodically in the Official Journal (Patents). The on-line databases considered for search are also listed periodically in the Official Journal (Patents).