

(21) Application No 9904619.5

(22) Date of Filing 01.03.1999

(71) Applicant(s)
John Richard Carew Armstrong
76 Dukes Avenue, London W4, United Kingdom

(72) Inventor(s)
John Richard Carew Armstrong

(74) Agent and/or Address for Service
John Richard Carew Armstrong
76 Dukes Avenue, London W4, United Kingdom

(51) INT CL⁷
F03B 13/10 3/04 13/26 15/00

(52) UK CL (Edition R)
F1T TC TDC TGF T111 T121 T131 T149 T301 T311 T619
U1S S1987 S2081

(56) Documents Cited
GB 2256011 A WO 99/02853 A1 WO 81/00595 A1
US 4864152 A US 4850190 A

(58) Field of Search
UK CL (Edition R) F1T TC TDC TGF
INT CL⁷ F03B 13/10 15/00
ONLINE: EPODOC, JAPIO, WPI

(54) Abstract Title
Submersible water flow turbine with buoyancy chamber

(57) A turbine 1 to harness energy from river or sea water flows or currents has a rotor rotating about a near horizontal axis and supported by a buoyancy chamber 2. A restraining arm 3, which is rigid, telescopic or flexible, ties the turbine 1 to an anchorage 4 via a bearing 5, so that the turbine is free to follow current direction changes and accommodate water level changes. The buoyancy of the chamber may be changed by pumping air into the chamber 2 and water out, to adjust power output and blade tip clearance. Sufficient air can be used to cause the turbine to flip over (fig 3), lifting the rotor clear of the water for maintenance. The chamber 2 may be streamlined, or have rotors on side arms (fig 4), and may include a sealed tank and a tank in which the amount of air and water may be trimmed. An electricity generator in the turbine may be used as a brake. Electricity may be removed by an armoured cable, a controllable rudder ensuring that the turbine swings so as not to wind up the cable in the event of tide change.

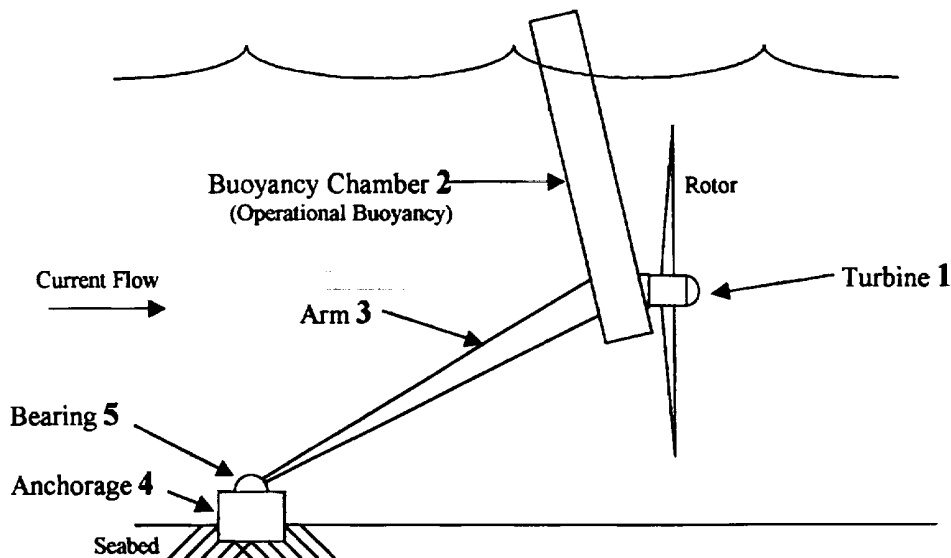

Figure 1 Normal Operation, Single Rotor, Rated Power: Side View

The Drawings

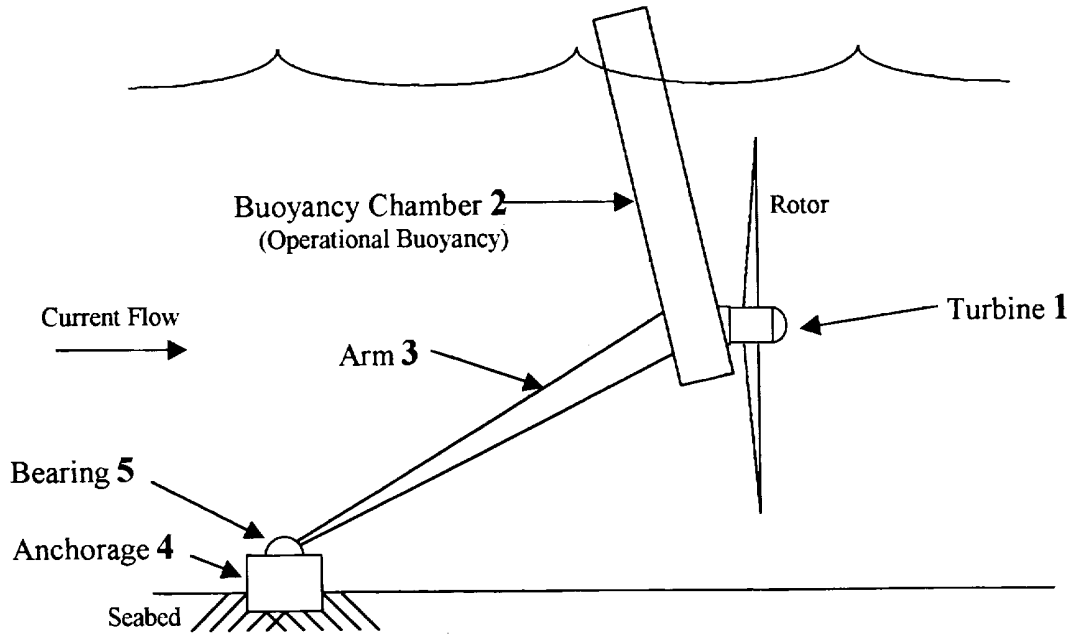

Figure 1 Normal Operation, Single Rotor, Rated Power: Side View

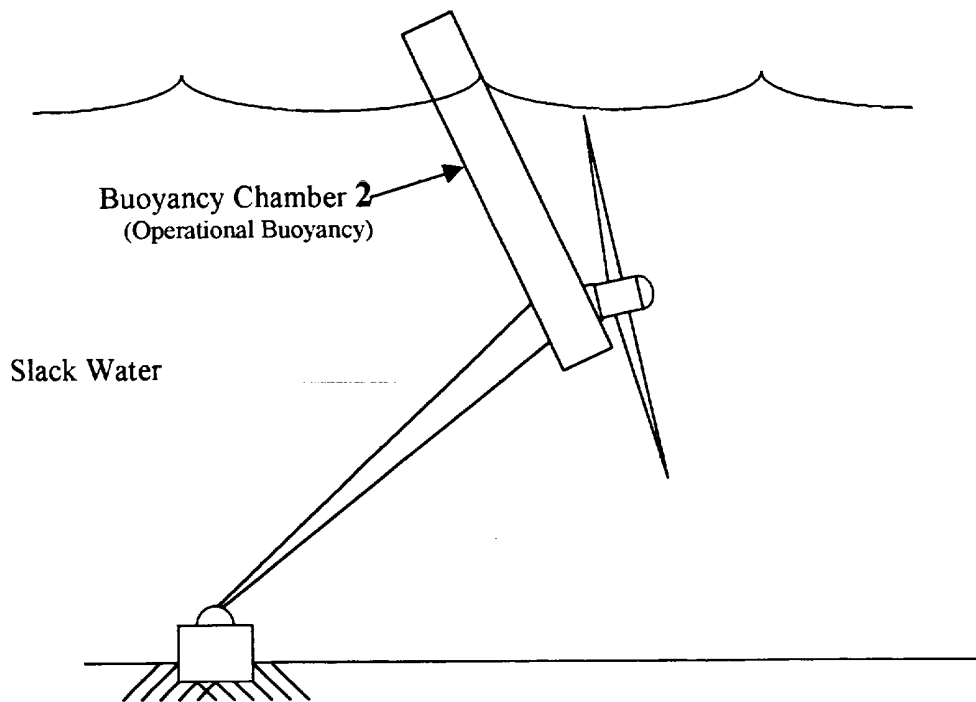

Figure 2 Turbine Off-load or Stopped

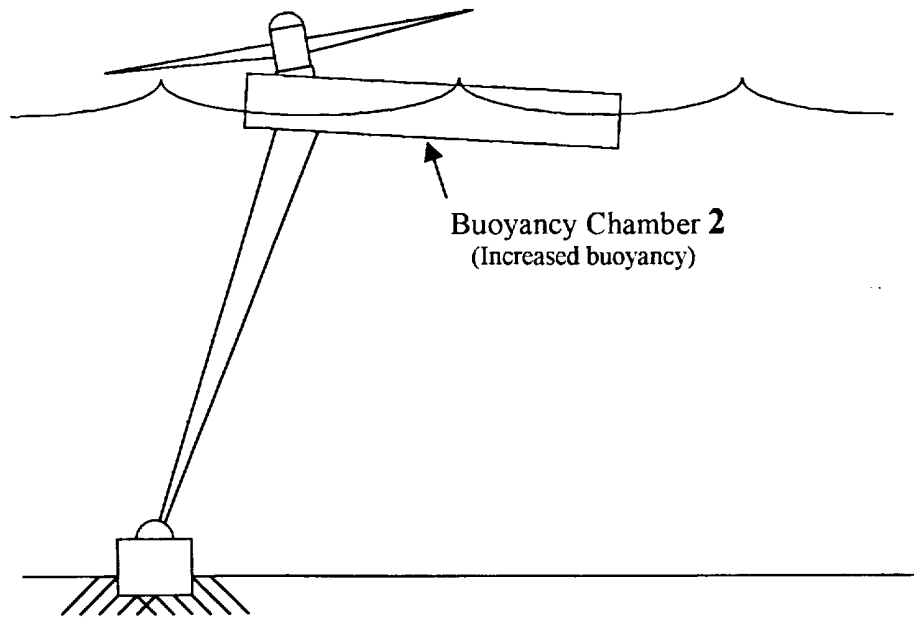

Figure 3 Turbine in Maintenance Position

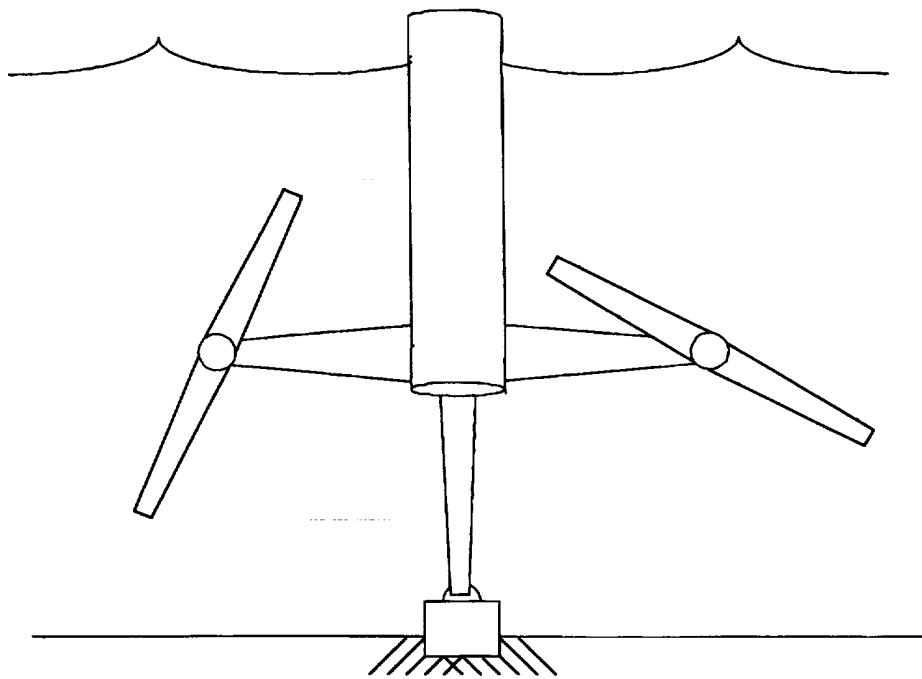

Figure 4 Twin Rotor Alternative (Looking Upstream)

Semi-Submersible Current Turbine

Introduction

It is well known that electricity-producing turbines can be built to harness energy from the free-stream flow of water. There are for instance turbines with horizontal-axis rotors which convert the energy from fast-flowing rivers originating in the Adirondack Mountains into mechanical power, and hence generate electricity for the City of New York. There are also turbines with vertical-axis rotors suspended below tethered platforms floating in rivers and tidal estuaries of third world countries which supply electricity to local communities.

Submerged free-stream turbines offer to generate energy in a sustainable way without environmental impact, like the visual intrusion of wind turbines for instance, and with the predictability of tidal, thermal or river current flows. It is interesting, therefore, that they have not been more used as a renewable energy source in Europe or the United States. Partly, the problem is one of scale: fast-flowing rivers are rarely deep enough for much energy to be gathered without major diversion structures, whereas larger turbines built for deeper offshore flows have to handle major storm loads and still remain economic.

Two types of structure have to date been proposed for these larger turbines: seabed cantilevered towers on which horizontal-axis turbines can swing to align with the current, and floating platforms carrying beneath them vertical-axis turbines (eg of the Francis type). Floating platforms will not be considered further here, since the movements and wave loadings created by storms would tend to render a suitable structure uneconomic.

The seabed cantilevered structure largely avoids storm-loadings, but has a number of major disadvantages. Firstly, a horizontal-axis turbine rotor has to be made to swing (yaw) to align with the current direction. This requires yaw bearings, a motor drive, sensor and control system in the same way as for a wind turbine. Secondly, the thrust on a water current turbine is many times that of an equivalent rated wind turbine, and a foundation firm enough to withstand the moments from this thrust has to be provided in the seabed. Variations in these large thrust forces, due to current turbulence or misalignment of the rotor, give rise to cyclical dynamic forces which the foundation, structure and mechanisms would have to be sturdy enough to withstand. Moreover, the rigid coupling to the ground is likely to give structural eigenfrequencies in the range of the excitational frequencies, amplifying the cyclic dynamic loads at and around conditions of resonance.

The installation of such a foundation, and the mounting of the turbine to it, would require substantial offshore equipment plus suitable weather and tidal windows (in an area, by definition, of very high tidal flow). Similarly, maintenance of the turbine equipment (typically transmission, generator, yaw and control systems) cannot reasonably be done underwater, and so means would have to be provided for all the working systems to be lifted out of the water, for even the smallest maintenance or inspection task.

The feasibility of water current turbines could be much improved if cheaper and more practical means could be found to support the turbines in the water, to transport and install them on site, and to arrange for dry access to all the working parts. This is the aim of the present invention, where these means are provided by controlled buoyancy in a partly

submerged structure. It is well known that, for instance, a semi-submersible offshore drilling rig, where most of the buoyancy comes from structures well below the water-line and is therefore not subject to wave loads, combines great positional and heave stability with the ability to be floated from one site to the next.

Present Invention

The present invention may be understood by reference to Figure 1. A horizontal axis, or near-horizontal axis turbine 1 is supported in the water by a buoyancy chamber 2. A restraining arm 3, which can be either rigid or a flexible and/or telescopic tether, ties the turbine back to an anchorage 4 by means of a bearing 5 which allows the arm and turbine to swing and rotate in all 3 planes. The turbine is therefore free to follow all changes in current direction. The arm 3 may be telescoped to accommodate the turbine to different water depths. The anchorage 4 is sized so as to resist all thrust and uplift forces without shifting, and may for instance consist of a sufficiently heavy concrete block lowered into place from a surface vessel. Under conditions of full current flow, rated power and maximum thrust (Figure 1), the buoyancy is sufficient to hold the turbine up so that the rotor runs with sufficient clearance from the seabed. As the flow decreases, or if the turbine is stopped for any reason, the moment due to thrust also decreases, and the turbine rises in the water (Figure 2). Access may then be gained to the top of the buoyancy chamber where controls and other equipment needing dry access may be located. In particular, for maintenance, the buoyancy may be increased (for instance by pumping air into the chamber and water out) so that the chamber rises more and more out of the water. At some point, the weight of material out of the water will cause the whole turbine to flip on to its back (Figure 3) so that the buoyancy chamber now lies along the surface and the turbine and rotor come clear of the water for access and maintenance.

An attractive feature of this arrangement is that while running, the turbine is free to find its own position of equilibrium relative both to the current direction and to the effects of turbulence and imbalances which would otherwise induce considerable loads if restrained by a rigid structure. There are only vector forces of thrust and uplift, and no moments, acting on the foundation: drive torque for instance is balanced by a few degrees of transverse inclination of the buoyancy chamber. With the free-swinging turbine there are no support cantilever spring effects and any vibrational energy is dissipated by the viscosity of the water and the damping forces on the moving parts. Moreover, the virtually submerged buoyancy chamber isolates the structure from most of the effects of wave-loading, unlike for a floating structure. All these effects reduce loads on the structure and allow a more economic design.

Because the rotor runs downstream of the buoyancy chamber, the latter would preferably be made with an oval or streamlined section to minimise turbulence on the rotor. Alternatively, two or more rotors could be placed on side-arms (Figure 4) and the buoyancy chamber could again be circular in section. This arrangement has the added advantage of increasing the swept area at given water depth. In fact, this downstream tethered arrangement is a preferred one for a two-rotor turbine, because thrust imbalance between the rotors (for instance if one stops before the other) would result merely in a degree of off-stream operation rather than in a massive yaw moment which would need to be resisted in the cantilevered tower system.

When the rotor is stopped, for instance for maintenance, some form of parking brake would be required to hold it still. This could be provided on the electrical generator of the turbine, on the high speed shaft of the speed-up gearbox, if one is used, or on the rotor of the turbine. This brake could also be made of sufficient size and capacity to stop the rotor from any conceivable operating condition, for instance the loss of grid connection at full current flow. This is not necessarily an essential feature of the invention, but a likely requirement of a practical embodiment.

In the maintenance position, the buoyancy chamber and the arm to the seabed help to provide stability for the structure so that there is a steady platform for maintenance, again unlike for the floating structure.

Various operational refinements could be made using the buoyancy system. For instance, buoyancy could be increased during strong flow and decreased at slack water so that the turbine rotor stays more nearly axial with the flow. It may even be possible to limit turbine power at times of full flow by lowering it towards the seabed. This would allow the rotor to run in the slacker deep water and/or tilt the rotor plane to reduce its swept area. Care would have to be taken to ensure adequate blade tip clearance from the seabed; for instance the buoyancy chamber could be continued down to form a physical strut grounding the structure and preventing blade tip strike.

Various methods are available for the provision of buoyancy. Part of the buoyancy could take the form of a "hard tank", in which a hollow structure contains air or gas at a fixed pressure (either atmospheric or local hydrostatic), and is sealed (apart maybe from a bilge pump for evacuating water which has leaked in). Part may be provided by a "soft tank" containing both air (gas) and water, the water being free to enter to a degree which can be controlled by the air pressure. Part may be controlled by a "trim tank" in which the amount of water which can enter is controlled directly, for instance by valves and/or pumps. The air (gas) supply may either be via an on-board compressor, or from high-pressure storage cylinders or an exo-thermal chemical reaction in the event of power failure.

A further advantage of this configuration is that the whole turbine can be made buoyant and floated into position. The attachment to the anchorage can be made before the latter is lowered into position, making the installation simple and far easier than the alternative of driving piles and fitting sleeves. The anchorage can even be a buoyant structure itself, floated out full of air and then flooded or filled with gravel or mud to sink it to the seabed.

It may be advantageous to assist, or even replace, buoyancy trimming by mechanical means for moving the centre of gravity, for instance by the shifting of ballast.

A crucial part of the design will be the power take-off arrangements, specifically, in the case of a turbine generating electricity, the location of subsea cabling and maybe a transformer. In the present invention, it is suggested that the power cables are brought to the dry chamber at the top of the buoyant part, where the switchgear and transformer could be located. The site connection could then, for example, be run as armoured cable down the outside of the structure, a large loop left around the anchorage, and the cable taken off to shore or the next installation. It may be necessary to provide a controllable flap or rudder to ensure, for example, that the turbine always swings at tide change in a direction which does not wind up the cable.

The Claims

1. A free-stream current flow turbine in which the turbine is supported in the water, or partly supported in the water, by one or more buoyancy chambers.
2. A device according to 1 in which the turbine has one or more rotors whose axes are horizontal or near-horizontal.
3. A device according to 1 or 2 in which the turbine is located by rigid or flexible tethers in such a way that it is free to swing around (yaw) to follow the prevailing current direction; and/or to swing up and down (pitch) to follow the net forces on it; and/or is free rotate in the plane of the rotor(s) until the net torque is balanced by buoyancy displacements.
4. A device according to any of 1-3 in which the structure is only partly submerged, so that there is natural stability in the vertical operating level of the turbine under different operational conditions.
5. A device according to any of 1 – 4 in which the buoyancy is trimmed, for instance by changing the amount of water in the buoyancy chamber(s), so as to improve operational performance under different conditions and at different current flows.
6. A device according to any of 1 - 5 in which the provision of further buoyancy, for instance by forcing more water out of the buoyancy chamber(s), positions the turbine in such a way that the operational parts of the turbine are raised clear of the water for access and maintenance.
7. A device according to any of 1 – 6 in which the provision of buoyancy allows the turbine and structure to be floated into position for installation and/or removal.
8. A device according to any of 1 – 7 in which mechanical means are used in addition to or instead of buoyancy changes to move the centre of gravity of the free-swinging structure, for instance by the shifting of ballast.
9. Means for any of 1 – 7 of providing the required degree of buoyancy; either by a powered air compressor, or by the use of pre-compressed gas, or by gas released by chemical reaction or evaporation.
10. Means of providing sensors and an autonomous control system for the automatic operation of elements 1 – 9 in pre-determined response to various conditions.
11. A means of anchorage for any of 1 – 10 in which a buoyant foundation structure is floated into position and then sunk into position by flooding the structure with water, mud, gravel or other material to provide an attachment for the turbine tether, this connection being made either before or after flooding.
12. Means for enhancing or regulating the transfer of water between buoyancy chambers to stabilise the structure (eg pumps, throttles, anti-slosh panels).
13. Means for controlling the attitude of the turbine structure, for instance during current or tidal direction changes to avoid cable wind-up (eg flaps or rudders).

Amendments to the claims have been filed as follows

1. A free-stream current flow turbine in which an electricity-producing turbine is supported in the water, or partly supported in the water, by one or more buoyancy chambers.
2. A device according to 1 in which the turbine has one or more rotors whose axes are horizontal or near-horizontal.
3. A device according to 1 or 2 in which the turbine is located by rigid or flexible tether arms in such a way that it is free to swing around (yaw) to follow the prevailing current direction; and/or to swing up and down (pitch) to follow the net forces on it; and/or is free rotate in the plane of the rotor(s) (roll) until the net rotor torque is balanced by buoyancy displacements.
4. A device according to any of 1-3 in which the buoyant structure is mostly, but not fully submerged, so that there is natural stability in the vertical operating level of the turbine under different operational conditions, whilst the turbine itself remains relatively unaffected by wave action.
5. A device according to any of 1 – 4 in which the buoyancy is trimmed, for instance by changing the amount of water/gas in the buoyancy chamber(s), so as to improve operational performance under different conditions and at different current flows.
6. A device according to any of 1 - 5 in which the provision of additional buoyancy, for instance by forcing more water out of the buoyancy chamber(s), positions the turbine in such a way that the operational parts of the turbine are raised clear of the water for access and maintenance.
7. A device according to any of 1 – 6 in which the provision of buoyancy allows the turbine and structure to be floated into position for installation and/or removal, means being provided at one or other end of the tether arm for coupling/releasing the turbine.
8. A device according to any of 1 – 7 in which the tether arm may be telescoped to allow for differences in water depths at various locations, or for periodic adjustments for changing operational conditions such as water level, or for installation/removal, or for maintenance access.
9. A device according to any of 1 – 8 in which mechanical means are used in addition to or instead of buoyancy changes to move the centre of gravity of the free-swinging structure, for instance by the shifting of ballast.
10. Means for any of 1 – 8 of providing the required degree of buoyancy; either by a powered air compressor, or by the use of pre-compressed gas, or by gas released by chemical reaction or evaporation.
11. Means of providing sensors and an autonomous control system for the automatic operation of elements 1 – 10 in pre-determined response to various conditions.
12. A means of anchorage for any of 1 – 11 in which a buoyant foundation structure is floated into position and then sunk into position by flooding the structure with water, mud, gravel

or other material to provide an attachment for the turbine tether, this connection being made either before or after flooding.

13. Means for enhancing or regulating the transfer of water between buoyancy chambers to stabilise the structure (eg pumps, throttles, anti-slosh panels).

14. Means for controlling the attitude of the turbine structure, for instance during current or tidal direction changes to avoid cable wind-up (eg flaps or rudders).





Application No: GB 9904619.5
 Claims searched: 1-8

Examiner: Terence Newhouse
 Date of search: 19 July 2000

Patents Act 1977
Search Report under Section 17

Databases searched:

UK Patent Office collections, including GB, EP, WO & US patent specifications, in:
 UK CI (Ed.R): F1T(TC,TDC,TGF)
 Int CI (Ed.7): F03B 13/10 15/00
 Other: ONLINE: EPODOC, JAPIO, WPI

Documents considered to be relevant:

Category	Identity of document and relevant passage	Relevant to claims
X	GB 2256011 A (I T POWER), see whole document, particularly pages 6 and 7	1-8 at least
X	WO 99/02853 A1 (SINVENT), see particularly figure 1 noting turbines 16	1,5,7 at least
X	WO 81/00595 A1 (KLEM), see particularly figure 2 noting buoyant turbine casing 1	1-3,7 at least
X	US 4850190 (PITTS), see whole document	1-3,7 at least
X	US 4864152 (PEDERSEN), see particularly figure 1 noting chamber 3 and turbines 21	1-4,7 at least

X	Document indicating lack of novelty or inventive step	A	Document indicating technological background and/or state of the art.
Y	Document indicating lack of inventive step if combined with one or more other documents of same category.	P	Document published on or after the declared priority date but before the filing date of this invention.
&	Member of the same patent family	E	Patent document published on or after, but with priority date earlier than, the filing date of this application.