

(No Model.)

E. KOLL.
WOOD COLUMN.

No. 589,836.

Patented Sept. 14, 1897.

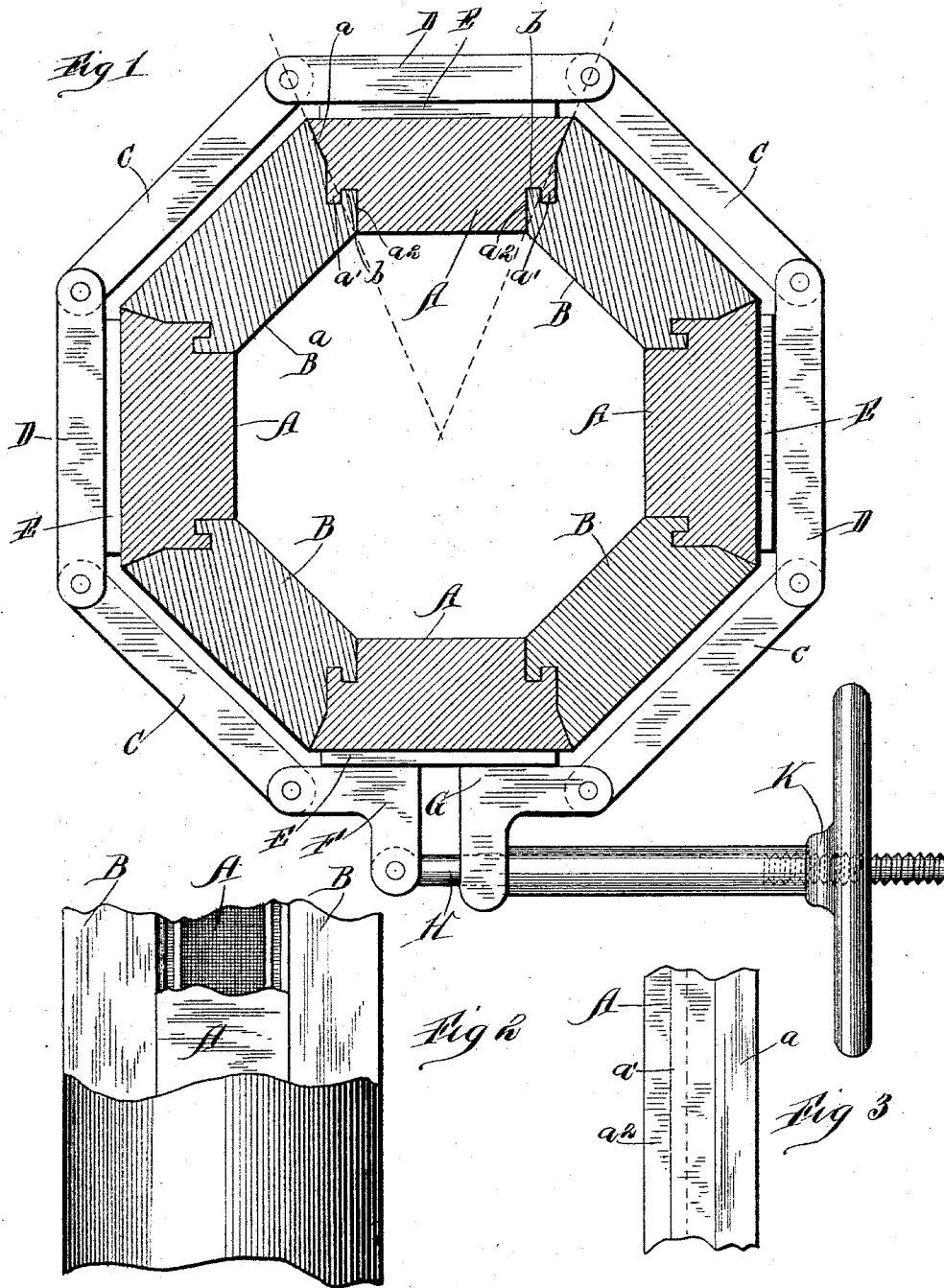

Witnesses
W. C. Coolidge
C. A. Crawford

Inventor
Ernest Koll
By Louis K. Gilson
att.

UNITED STATES PATENT OFFICE.

ERNST KOLL, OF MILWAUKEE, WISCONSIN.

WOOD COLUMN.

SPECIFICATION forming part of Letters Patent No. 589,836, dated September 14, 1897.

Application filed April 1, 1897. Serial No. 630,271. (No model.)

To all whom it may concern:

Be it known that I, ERNST KOLL, a citizen of the United States, residing at Milwaukee, in the county of Milwaukee and State of Wisconsin, have invented certain new and useful Improvements in Wood Columns; and I do declare the following to be a full, clear, and exact description of the invention, such as will enable others skilled in the art to which it appertains to make and use the same, reference being had to the accompanying drawings, and to the letters of reference marked thereon, which form a part of this specification.

This invention relates to that class of wood columns which are built up of a number of longitudinal segmental sections glued together, the column being ordinarily turned to the desired form after assembling. Columns of this kind have usually been made of sections having their meeting edges uniformly beveled, though in some instances the joints have been matched similar to the matched joints in flooring or a key-piece has been inserted.

The object of this invention is to simplify the assembling of the sections of the column, to provide a locked joint, and to secure an extensive gluing-surface.

The invention consists in so forming the several sections of such a column that their joints interlock when alternate sections are forced inwardly, the meeting faces being of such form that the pressure upon these entering sections forces the remaining sections outwardly.

In the drawings, Figure 1 is a plan section of my improved column, showing the parts assembled and held by a clamp. Fig. 2 is a detail elevation of the column, a portion having been turned to cylindrical form and a portion of one of the sections being broken away; and Fig. 3 is a detail edge elevation of one of the sections.

The column is built up of two sets of longitudinal sections A B alternately arranged. The meeting edges of these two sections are so formed that pressure upon one set, as A, to force them inwardly, forces the other set, as B, outwardly and completes the locking of the joints.

The column may be of any desired number of sections. As shown, it is made octagonal, each of these several sections extending through forty-five degrees of the circumference of the column and is generally in the form of a section of a wedge, the outer and inner edges of each of its contacting faces falling upon the same radius of the column. The entering sections A are provided with a longitudinal tongue a' upon each of their contacting faces, these tongues extending inwardly in a direction perpendicular to the cord of the arc subtended by the section. The inner portion a^2 of the contacting faces of these sections are parallel and in planes corresponding to the direction of the tongues, and the outer portions a of these contacting faces are oblique, their planes being upon radii of the column. The conformation of the groove inclosed by the tongue a' is not material, but the outer face of the tongue must not be deflected beyond the perpendicular to the cord in question. The contacting faces of the sections B are the counterparts of those of section A and are provided with outwardly-directed tongues b , adapted to enter the groove inclosed by the tongue a' .

In assembling the sections the column is built up by commencing with one of the outwardly-bearing sections B, and it will be seen that the final section may be inserted without difficulty. When the sections have been assembled, they are forced together by the application of a suitable clamp, such as I have shown, the pressure of the oblique portions a of the contacting faces of the sections A upon the cooperating portions of the sections B forces the latter sections outwardly and causes the firm interlocking of the longitudinal tongues of the two sections.

The clamp shown consists of the links CD, corresponding in number with the sections of which the column is formed, alternate links being provided with bearing-blocks, as E, that pressure may be applied to the entering sections A and not to the intermediate sections B. One of the links of the clamps is transversely divided into the portions F G, each of which has a laterally-extending lug to which pressure may be applied by means of a suitable screw-threaded draw-bar H and

a cooperating nut K. After the glue has set the clamp may be removed and the column turned as may be desired.

I claim as my invention—

- 5 A column composed of a plurality of circumferentially-arranged sections, more than four in number, adjacent sections meeting to form joints, the general direction of which follow radii of the column, the contacting
10 faces of alternate sections having inwardly-directed projections inclined away from the

radius, and the remaining sections having outwardly-directed projections inclined away from the radius, the projections of the two sets of sections being adapted to interlock. 15

In testimony whereof I affix my signature in presence of two witnesses.

ERNST KOLL.

Witnesses:

FRED C. LORENZ,

C. E. ALTER.