

J. O. CLÉMENT.

MACHINE FOR PRINTING AND ADDRESSING CIRCULARS, &c.

APPLICATION FILED JUNE 11, 1902.

NO MODEL.

3 SHEETS—SHEET 2.

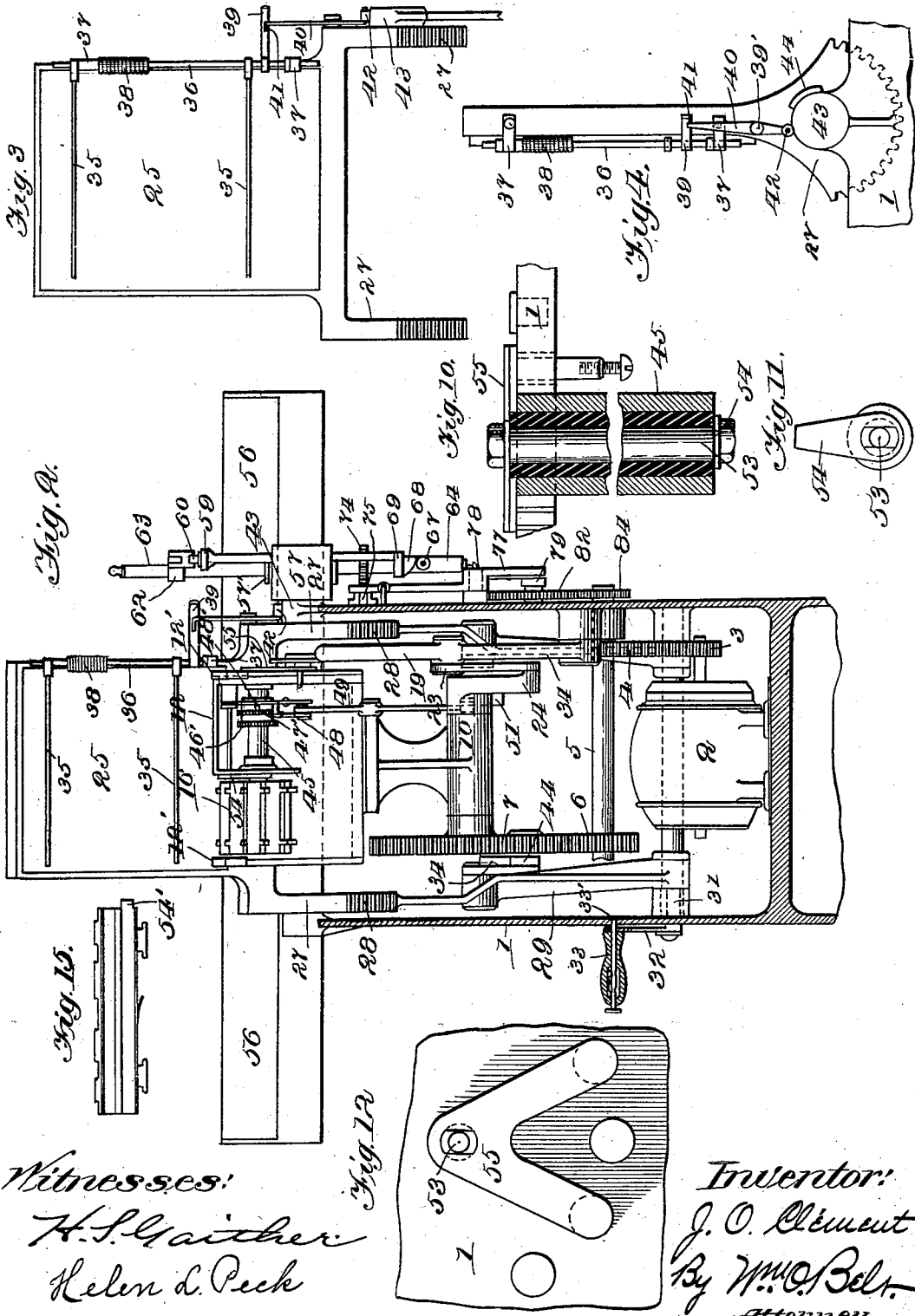

Witnesses:
 H. S. Gaither
 Helen d. Peck

Inventor:
 J. O. Clément
 By Wm. C. Bell
 Attorney

No. 722,811.

PATENTED MAR. 17, 1903.

J. O. CLÉMENT.

MACHINE FOR PRINTING AND ADDRESSING CIRCULARS, &c.

APPLICATION FILED JUNE 11, 1902.

NO MODEL.

3 SHEETS—SHEET 3.

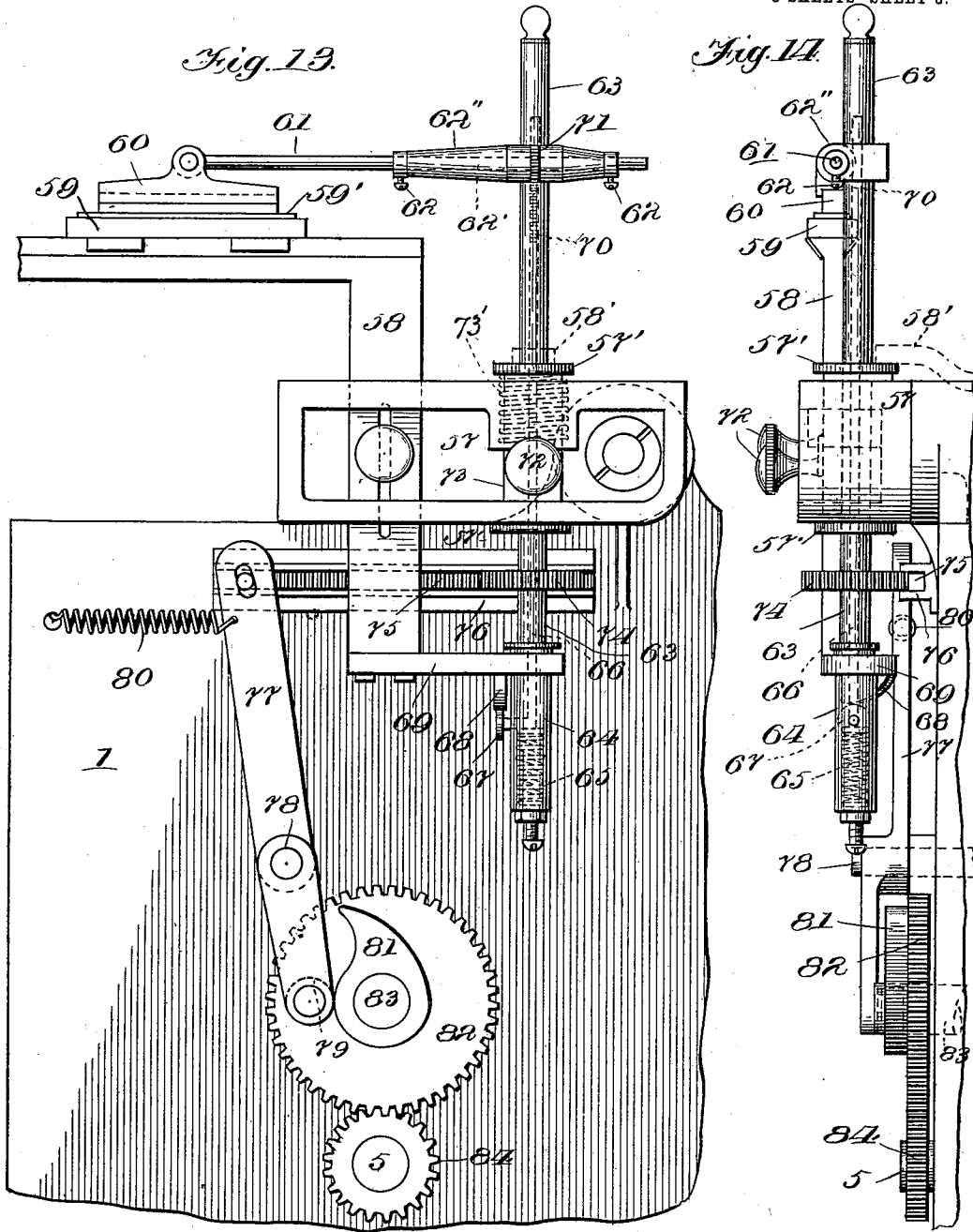

Witnesses:

H. S. Miller
Kelen d. Peck

Inventor:

J. O. Clément
Wm. O. Bell
Attorney.

UNITED STATES PATENT OFFICE.

JOSEPH OSWALD CLÉMENT, OF LONDON, ENGLAND, ASSIGNOR TO
ADDRESSOGRAPH COMPANY, OF CHICAGO, ILLINOIS, A CORPORATION OF ILLINOIS.

MACHINE FOR PRINTING AND ADDRESSING CIRCULARS, &c.

SPECIFICATION forming part of Letters Patent No. 722,811, dated March 17, 1903.

Application filed June 11, 1902. Serial No. 111,165. (No model.)

To all whom it may concern:

Be it known that I, JOSEPH OSWALD CLÉMENT, a subject of the King of Great Britain, residing at London, in the county of Middlesex, England, have invented certain new and useful Improvements in Machines for Printing and Addressing Circulars, &c., of which the following is a specification.

This invention has for its object to print circular-letters and a separate address or superscription on each letter in one machine; and a further object is to print the date or an autograph signature, or both, on the letters at or about the time they are printed.

It is my object to provide a printing-machine capable of printing circulars and the like from one form or printing-surface and also of printing additional matter on the circulars from another form or printing-surface, such as the names or names and addresses of persons to whom the circulars are to be sent, whereby the circulars will be separately addressed, and also to provide for printing the date or autograph signature on the circular, so that the circular is complete and ready for mailing when removed from the machine.

With these and other ends in view the invention consists in the novel construction and arrangement of parts hereinafter pointed out, and illustrated in the accompanying drawings, showing one embodiment of the invention, and in which—

Figure 1 is a sectional view on the line A B of Fig. 2. Fig. 2 is a sectional view showing the front of the machine partly broken away. Figs. 3 and 4 show a front elevation and an end view, respectively, of the platen and the devices for holding the sheets of paper in position while being printed. Fig. 5 is a plan view, and Fig. 6 is a side view, partly in section, of a portion of the bed on which the type-forms are arranged. Fig. 7 is a transverse sectional view of one side of the bed and the bar by which the type-holders are held in position. Fig. 7^a is a side view of the other side of the printing-table. Fig. 8 is a transverse sectional view of one of the inking-rollers, and Fig. 9 is a longitudinal sectional view of a portion of the roller, showing also the lever-arm in section. Fig. 10 is a horizontal sec-

tion, and Figs. 11 and 12 are opposite end views, of the mechanism for automatically stopping the machine after the last form on the chain of address-forms has been printed. Figs. 13 and 14 are elevations at right angles to each other of attachments for printing additional matter, such as the date, autograph signature, &c. Fig. 15 shows a tray which may be used.

Referring to the drawings, in which like reference characters indicate similar parts in all of the figures, 1 designates the main frame of the machine, and 2 is an electric motor which furnishes the driving power and which carries a pinion 3, gearing with a spur-wheel 4 on a counter-shaft 5, which also carries a pinion 6, gearing with a spur-wheel 7 on the main driving-shaft 8, which is mounted in a bearing-bracket 10, depending within the main frame from the top thereof.

The machine shown in the drawings is constructed to print a circular and at the same time print on each circular an address, as well as the date or autograph signature. The types from which the body of the circular is to be printed are arranged in trays 11, Figs. 5 and 6, each line of type being preferably set up in a separate tray, although this is not shown, and an entire form may be set up in a tray, or the trays may be constructed to contain several lines of type. The trays are arranged in proper order on the printing-table 12, which I prefer should be inclined, as shown in Fig. 1, and each tray is provided at its ends with lips 13, the lip on one end of the tray engaging a groove or undercut in one side 12' of the printing-table and the lip on the other end of the tray being arranged beneath a removable locking-bar 14, which is fitted in a groove or recess in the opposite side 12'' of the printing-table. The locking-bar is secured in its depressed position by means of a pin 15, arranged in a hole in the side 12'' of the printing-table and a registering hole in the bar, and when it is desired to remove any one or more of the trays from the printing-table the pin 15 is first withdrawn from the holes to permit the locking-bar to be removed, so that any one of the lines of type and the tray holding it may be removed and, if de-

sired, replaced. The types carried by the trays constitute the form from which the body of the circular is printed, and it is apparent that the same choice as to arrangement and display may be exercised as in preparing an ordinary printing-form. This form may be used repeatedly when a number of circulars are struck off; but it is apparent that the address-form must be constantly changed if it is desired to separately address each circular. This I accomplish by employing a rotating drum 16, which is suitably supported in an opening 16' in the printing-table and over which runs an endless chain of trays, each tray containing type for printing the address or name and address of a person or company to whom the circular is to be sent. These chains may be made up of trays constructed in any suitable manner for holding rubber or metal type or printing forms or plates of any kind and in any way, and they are connected together, preferably, in the form of an endless chain to pass over the drum, so that each circular will be separately addressed at the same time it is printed, and as each tray in the chain contains an address different from the others it is apparent that each circular will be correspondingly addressed to different parties. Both the body-form and the address-form are arranged to lie in the same plane, so that they can both be inked by a single inking device, which consists, preferably, of a pair of inking-rollers 17, Figs. 1, 8, 9, carried by a frame 18, which comprises a radially-adjustable post 18', arranged in a socket 19' in the lever-arm 19, which is mounted on the stud 20 in the interior of the frame. These inking-rollers may be constructed and supplied with ink in any suitable manner; but I prefer that each roller should comprise a cylindrical core 21, Figs. 8 and 9, surrounded by felt or other suitable absorbent material 22, to hold the ink and provided with a covering 22' of silk. The core may be made hollow and perforated, as shown, and the ink introduced therein at one end and permitted to pass through the perforations to the felt. The lever-arm 19 is connected by a link 23, Figs. 1 and 2, to a crank 24 on the main shaft 8, so that when the shaft is rotated the lever-arm will be actuated to carry the inking-rollers back and forth over both the body-form 11' and the address-form then in operative position on the drum 16. The inking-rollers are caused to contact properly with the type by means of a spring 24', Fig. 9, in the socket of the lever-arm, which is connected at one end to the arm and at its other end to the post 18' and which exerts its tension on the post to draw it inwardly and press the rollers against the type.

The sheets to be printed are placed one at a time on a platen 25, Figs. 1 and 2, which is mounted to turn on studs 26 on the main frame. This platen is provided with toothed segments 27, which mesh with corresponding segments 28 on levers 29, which are carried

by the eccentric shaft 30, mounted in bearings 31 on the main frame. This shaft is provided with a crank-arm 32, Fig. 2, outside of the frame, by which the said shaft can be turned in its bearings to move the segments 28 into and out of engagement with the segments 27, as required, said crank-arm being provided with a detent or other device which may be in the form of a spring-controlled bolt 33, arranged to enter an opening 33' in the frame to lock the shaft and hold the segments in engaged or disengaged position. The levers 29 are connected by links 34 to crank-pins 44, one of said crank-pins being on the crank 24, whereby the inking-rollers are operated, and the other crank-pin being on the spur-wheel 7, fast on the main shaft 8. When the segments are disengaged, the platen will remain inoperative while the other parts of the machine continue to work, so that the inking-rollers can be caused to travel back and forth over the type as often as required to thoroughly ink the forms before commencing to print. The sheet to be printed is held in position on the platen 25, Figs. 3 and 4, by rods 35, carried by a spindle 36 and adjustably mounted thereon, so that they can be adapted to hold sheets of different sizes. The spindle 36 is mounted in bearings 37 on one side of the platen and is acted on by a torsion-spring 38, which operates to force the rods against the face of the platen. Projecting from the spindle 36 is an arm 39, and mounted on a stud 39' on the side of the platen is a lever 40, one end 41 of which bears on the arm 39, and its other end carries a roller 42, arranged to travel on the curved surface of a lug 43 on the frame. This lug is provided with a cam-surface 44, onto which the roller 42 passes as the platen moves into position to have a printed sheet removed therefrom, the end 41 of the lever 40 being thereby caused to press on the arm 39 and turn the spindle 36 in its bearings against the tension of the spring 38 and release the rods 35 from engagement with the printed sheet and carry them away from the platen, so that a fresh sheet can be placed thereon.

The drum 16 is mounted on a hollow shaft or spindle 45, carried in bearings beneath the printing-table 12, and a portion 46 of the side 12' of the printing-table is hinged, so that it can be turned outward to permit the endless chain to be placed on or removed from the drum. On the hollow shaft 45 is a wheel 45', having teeth 46', which are engaged by a pawl 47 on a rod 48, carried by a lever 49, pivoted in the frame, and provided at its lower end with a roller 50, which is held against a cam or tappet 51 on the main shaft 8 by a spring 52, connected to the rod 48, Fig. 1, and the table. The rotation of the main shaft will communicate an intermittent motion of partial rotation to the drum, and thereby bring a different address-form of the endless chain into printing position at each partial rotation of the drum. The drum is held rigidly during the printing

operation by means of a detent 48', carried by an arm 48'' and arranged to engage teeth 47' on the wheel 45', this detent being held normally in engagement with the teeth by means of a spring 48'''. The detent is released by the end of the rod 48 engaging a lug 48'''' on the arm 48'' during its forward movement, so that the drum can turn to present a new address-form in printing position.

10 Within the hollow shaft 45 is a rod 53, Figs. 10 to 12, carrying at one end an arm 54 and on its opposite end a contact-piece 55 for making and breaking the electric-motor circuit. On the form following the last of the series 15 in the endless chain of address-forms is a projection 54', which at the next partial rotation of the drum 16 after the last address is printed strikes the arm 54 and causes the rod 53 to partially rotate and move the contact-piece 20 55 so as to break the motor-circuit and automatically stop the machine. If the machine be driven by mechanical power, the lever-arm 54 may be constructed to act on a clutch to automatically stop the machine. I also provide a switch 9, Fig. 1, for switching on and 25 off the electric current by which the motor is driven. After all of the addresses on one chain of address-forms have been printed the chain may be removed from the drum 16 and 30 another chain arranged thereon, the contact-piece replaced in position to complete the motor-circuit, and the machine again started in operation.

The sheets to be printed are fed one by one 35 from a table 56 onto the platen 25 when the latter is in its complete open position, at which time the rods 35 are carried away from the face of the platen by reason of the roller 42 on the lever 40 engaging the cam-surface 44 and throwing the lever against the arm 39, 40 projecting from the spindle 36. As the platen moves forward into printing position the roller 42 leaves the cam-surface 44, and the spring 38 thereupon throws the rods 35 onto 45 the sheet and holds it securely in position while being printed. During the time the platen is moving into printing position the inking-rollers travel over the type-forms in one direction, and while the platen is moving 50 backward with the printed sheet the inking-rollers will travel over the type-forms in the reversed direction, so that the forms are inked twice for each impression.

In addition to the mechanism for printing 55 the body and address of a circular-letter I may also provide for printing additional matter—such as an autograph signature or a date, or both—and this is preferably done after the body and address have been printed and before the sheet is removed from the platen. 60 For this purpose a supplemental frame 57, Figs. 2, 13, and 14, is secured to the main frame and carries a vertically-adjustable bracket 58, which supports a horizontally-adjustable holder 59 for the ink-pad 59' for 65 supplying ink to the form. This pad may be made like the roller 17, Figs. 8 and 9, for a

continuous supply of ink or in any other desired manner. The form is carried in a holder 70 60, hinged to a horizontal rod 61, adjustably secured by one or more set-screws 62 in the socket 62' of a support 62'', which is attached to or made integral with a square or equivalently shaped hollow rod 63, which is adjustable vertically in the frame 57. The lower 75 end of the rod 63 is connected to a cylinder 64, containing a spring 65, which exerts upward pressure on the lower end of a rod 66, fitted to slide longitudinally in the hollow rod 63. This rod 66 carries a roller 67 at its lower 80 end, which travels in contact with a stationary cam-surface 68 on an arm 69, projecting from the bracket 58. The upper end of the rod 66 is provided with teeth 70, in the form of a rack which gears with a pinion 71 or 85 toothed segment mounted on the horizontal rod 61, so that a longitudinal movement of the rod 66 will impart a partial rotation to the rod 61. The rod 61 is free to slide through the pinion 71 or segment to permit of its being 90 adjusted in the socket 62'. The hollow rod 63 passes through and is adjustably connected by a thumb-screw 72 to a hollow sleeve 73, which is movable vertically to a limited extent in the frame 57, the said sleeve having 95 a collar or flange 57' at each end to engage with the frame 57 and limit its vertical movement. On one side of the platen is a projection 58', which is arranged to engage the upper end of the sleeve 73 when the platen descends in the printing operation to depress 100 said sleeve in opposition to the spring 73', contained in a recess in the frame 57, through which the sleeve 73 passes. As the sleeve is depressed in this manner the form carried in 105 the holder 60 is brought into contact with and inked by the ink-pad 59', and as the platen rises after the sheet is printed the pressure of the projection 58' is removed from the sleeve 73, so that the spring 73' may act to raise the 110 form from the ink-pad into position to be operated to print on the sheet carried by the platen. A toothed wheel 74 or segment is mounted on the rod 63, so that they will both 115 rotate together, but also permit the rod to slide freely in the wheel or segment, and this wheel gears with a rack 75, fitted to slide in guides 76 on the main frame and connected to one end of a lever 77, mounted on a stud 78 and carrying at its other end a roller 79, which 120 is held by a spring 80 in contact with a cam or tappet 81. The cam or tappet is rotatable with a spur-wheel 82, mounted on a stud 83 and meshing with a pinion 84, fastened on the counter-shaft 5, which is rotated through 125 gearing with the motor. The wheels 82 and 84 are so proportioned relatively to the driving-wheels that when the platen is in its vertical or nearly vertical position after the first printing operation is completed the rack 75 130 is caused by the cam or tappet 81 and lever 77 to slide in its guides and impart, through the wheel or segment 74, a partial rotation to the hollow rod 63, thereby bringing the auto-

graph signature form into contact with the sheet on the platen, the face of this form being turned in opposition to the platen by the rotation of the hollow rod, and this is effected as follows: As the hollow rod 63 is being 5 turned by the operation of the rack 75 the roller 67 on the lower end of the internal rod 66 is caused by the pressure of the spring 65 to travel up the cam-surface 68, and the 10 rod 66 slides upward in the hollow rod 63, so that the rack 70 on the upper end of the internal rod will impart, through the pinion or segment 71, a partial rotation to the rod 61, thereby bringing the face of the autograph-signature form into proper position. The 15 movement of the autograph-signature form is very rapid, and immediately after the impression thereof has been made on the sheet the form is returned to its normal position, 20 the cam or tappet 81 permitting the rack 75 to be moved by the spring 80 in the reverse direction, thereby returning the rod 63 and the parts carried thereby into their initial position in readiness for the next operation. 25 By constructing the parts to be adjustable vertically and horizontally the signature can be printed on any desired part of the sheet.

It is apparent that I may print a date instead of a signature by the mechanism just 30 described, or both a signature and date, or a printing-form of any character whatsoever may be provided for this supplemental printing operation. In some instances it may be found desirable to print matter in a letter or 35 circular in a different color, and this mechanism may be adapted for that purpose.

The machine may be operated in any manner—by electric power, as shown, or by hand 40 or foot power, or in any other suitable manner; but I have found an electric motor to be a very convenient source of power.

The machine is simple in construction, compact, and it is constructed to operate easily 45 and quickly and does not require any particular degree of skill.

I do not make any claim in this application to the forms which are used on the drum 16, as it is apparent that the operation of the machine is not dependent in any way upon the 50 particular construction of the forms which are used, and I may employ printing-plates in which the characters are stamped up directly from the plate itself or holders of suitable character and containing rubber or metal 55 type, the plates or holders being linked together in a suitable manner; nor do I limit myself to the use of an endless chain of such forms, as it is apparent that the requirements of the machine will be fully complied with 60 by feeding the forms to and around the drum in any manner which will bring them one at a time into printing position.

It will be observed from the foregoing description of my invention that it is particularly 65 useful in preparing circular-letters personally addressed and bearing an autograph signature, the latter being printed in a dif-

ferent color from the body and address of the letter, if desired; but the invention is by no means limited to this or any other particular 70 use, for it may be employed in printing letters, circulars, and any matter of any kind which may be found possible or desirable.

A great many manufacturers and others who send circulars or other matter to the 75 same persons from time to time now preserve their names and addresses in the form of the address-forms of some suitable character, to which I have referred, and it will be understood that with my machine circular-letters 80 in imitation of type-writing, if desired, can be quickly and repeatedly prepared and sent out with the expenditure of very little time and labor.

While the machine which I have shown and 85 described constitutes a desirable embodiment of the invention, it is apparent that many changes in the form, construction, and arrangement of parts may be made without departing from the spirit or sacrificing the ad- 90 vantages of the invention, and I therefore reserve the right to make all such changes and modifications as fairly fall within the spirit and scope of the invention.

Having thus fully described my invention, 95 what I claim, and desire to secure by Letters Patent, is—

1. In a machine of the character described, the combination with a platen for carrying a sheet into printing position, of a fixed form 100 for printing on the sheet and another form with means for automatically operating the same to print on the sheet after it is removed from the fixed form and while carried by said platen. 105

2. In a machine of the character described, the combination with a platen arranged to travel in the arc of a circle and carry a sheet forward into printing position, of means for 110 again printing on the sheet while carried by the platen and after the platen has moved back from the first printing position to its initial position.

3. In a machine of the character described, the combination of a platen for carrying a 115 sheet into printing position, means for oscillating the platen, a fixed form for printing on the sheet, and another form with means for automatically operating the same to print on the sheet after the first printing operation 120 and against said platen.

4. In a machine of the character described, the combination of a platen for carrying a sheet into printing position, means for moving said platen in the arc of a circle, and means 125 normally at one side of the path of travel of said platen and adapted to be operated to print on the sheet after the first printing operation is completed and while the sheet is carried by the platen. 130

5. In a machine of the character described, the combination of a fixed form, another form adapted to be changed for each sheet, said forms being arranged to print simultaneously

on the sheet, and an additional form adapted to print on the sheet after the first printing operation.

6. In a machine of the character described, the combination of a fixed form, another form adapted to be changed for each sheet, said forms being arranged to print simultaneously on the sheet, an oscillating platen for carrying the sheet into printing position, and an additional form adapted to print on the sheet after the first printing operation.

7. In a machine of the character described, the combination with means for carrying a sheet into printing position, of a fixed form, a series of independent forms with means for automatically feeding them to print successively on the sheets simultaneously with the fixed form, and another form with means for automatically operating the same to print on the sheet after it has been withdrawn from the first printing operation.

8. In a machine of the character described, the combination with means for carrying a sheet into printing position, of a main form and a supplemental form to print on the sheet at the same time, an additional form to print on the sheet after the first printing operation, and means for changing the supplemental form after each printing operation.

9. In a machine of the character described, the combination with means for carrying a sheet into printing position, of a main form and a supplemental form to print on the sheet at the same time, means for changing the supplemental form after each printing operation, an additional form and means for automatically operating the additional form to print on the sheet after the first printing operation and before it is removed from the carrying means.

10. In a machine of the character described, the combination with a main form and means for carrying a sheet of paper into printing position, of an intermittently-rotated drum, a series of forms traveling over said drum to print successively on the sheets and changing at each printing operation, and an additional form to print on the sheet after the first printing operation and before it is removed from the carrying means.

11. In a machine of the character described, the combination with means for carrying a sheet into printing position, of a series of forms arranged to print successively on the sheet, suitable operating means, and means carried with the series of forms to stop the machine after an impression has been taken from the last form, said means comprising a projection on one of the forms, a rod, an arm carried by the rod and arranged to be engaged by said projection, and means at the other end of the rod for disconnecting the operating devices of the machine.

12. In a machine of the character described, the combination with means for carrying a sheet into printing position, of a series of forms arranged to print successively on the sheets, electric operating means comprising

a contact-piece, a rock-shaft carrying said contact-piece, an arm on the end of said shaft, and a projection on one of the forms to engage said arm and rock the shaft.

13. In a machine of the character described, the combination with suitable operating means, of a platen for carrying the sheet into printing position, inking-rollers arranged to travel back and forth over the form, and means for disconnecting the platen to permit the same to remain stationary while the inking-rollers continue to operate.

14. In a machine of the character described, the combination of a pivoted platen, an eccentric-shaft, levers carried by said shaft, toothed segment connections between the levers and the platen, means for operating the levers to reciprocate the platen, and means for disconnecting the segments to permit the platen to remain stationary.

15. In a machine of the character described, the combination of a platen for carrying the sheet into printing position, a spindle supported on said platen, spring-controlled rods carried by the spindle, an arm on said spindle, a fixed cam-surface on the frame of the machine, and a lever adapted to be thrown by said surface to engage the arm and operate said holding-rods.

16. In a machine of the character described, a printing-table having a groove in one side thereof, a type-tray with lips at its ends, one of which is adapted to enter said groove, and a locking-bar arranged on the other lip and removably secured to the table.

17. In a machine of the character described, a printing-table provided with an opening therein, a drum arranged to rotate in said opening, a chain of printing-forms traveling over said drum, one side of said table being provided with a hinged portion to permit said chain to be placed on and removed from the drum.

18. In a machine of the character described, the combination with a platen and means for moving said platen in the arc of a circle, of a printing-form located at one side of the path of travel of said platen, and means for operating said form to print on the sheet carried by the platen after the latter has reached its normal position at rest.

19. In a machine of the character described, the combination of a printing-form, a horizontally-adjustable support therefor, and means for partly rotating said support to bring the form into operative printing position.

20. In a machine of the character described, the combination with a printing-form, of a horizontally-adjustable support therefor, a vertically-movable rod having toothed connection with said support, and means for automatically operating said rod to actuate the support and move the form into printing position.

21. In a machine of the character described, the combination with a platen and an ink-

pad, of a printing-form, an adjustable support therefor, and means for swinging said form horizontally between the pad and the platen and into alternate engagement there-
5 with.

22. In a machine of the character described, the combination with a printing-form, of a horizontal support therefor, a rod carrying said horizontal support, and means for im-
10 parting a rotary motion to the rod and to the support.

23. In a machine of the character described, the combination of a reciprocating platen carrying the sheet to be printed, a printing-
15 form supported alongside of the path of travel of said platen, and means for moving said form into the path of travel of the platen to print on the sheet carried thereby.

24. In a machine of the character described, the combination with a printing-form, of a support therefor, means for partly rotating
20 the form, and means for swinging the support and form in a horizontal plane.

25. In a machine of the character described, the combination with a printing-form, of a holder for the form, a support, and a rod
25 hinged to the holder and carried by said support.

26. In a machine of the character described, the combination with a printing-form, of a holder for said form, a support, means for
30 swinging and rotating the form, and a rod connected with the holder and support.

27. In a machine of the character described, the combination with a printing-form, of a holder for said form, a rod hinged to the
35 holder, a support for the rod, means operat-

ing on the rod to partly rotate the form, and means operating on the support for swinging the form in a horizontal plane. 40

28. In a machine of the character described, the combination of a printing-form, means for carrying a sheet into printing position, an additional printing-form, an inking-pad for
45 said form, and a device on said carrying means for causing the additional form to engage its inking-pad during the first printing operation.

29. In a machine of the character described, the combination of a printing-form, means
50 for carrying a sheet into printing position, an additional printing-form, an ink-pad and a support for said additional form, a device on the carrying means to move said additional form into contact with its ink-pad, and a
55 spring for raising said additional form.

30. In a machine of the character described, the combination of an upright rod, a horizontal rod supported on the upright rod, a printing-form carried by said horizontal rod,
60 and means for turning the upright rod to swing the form in a horizontal plane.

31. In a machine of the character described, the combination of an upright rod, a horizontal rod supported on the upright rod, a
65 printing-form carried by said horizontal rod, means for partly rotating the horizontal rod, and independent means operating at the same time for partly rotating the horizontal rod.

JOSEPH OSWALD CLÉMENT.

Witnesses:

WM. O. BELT,
J. S. DUNCAN.