

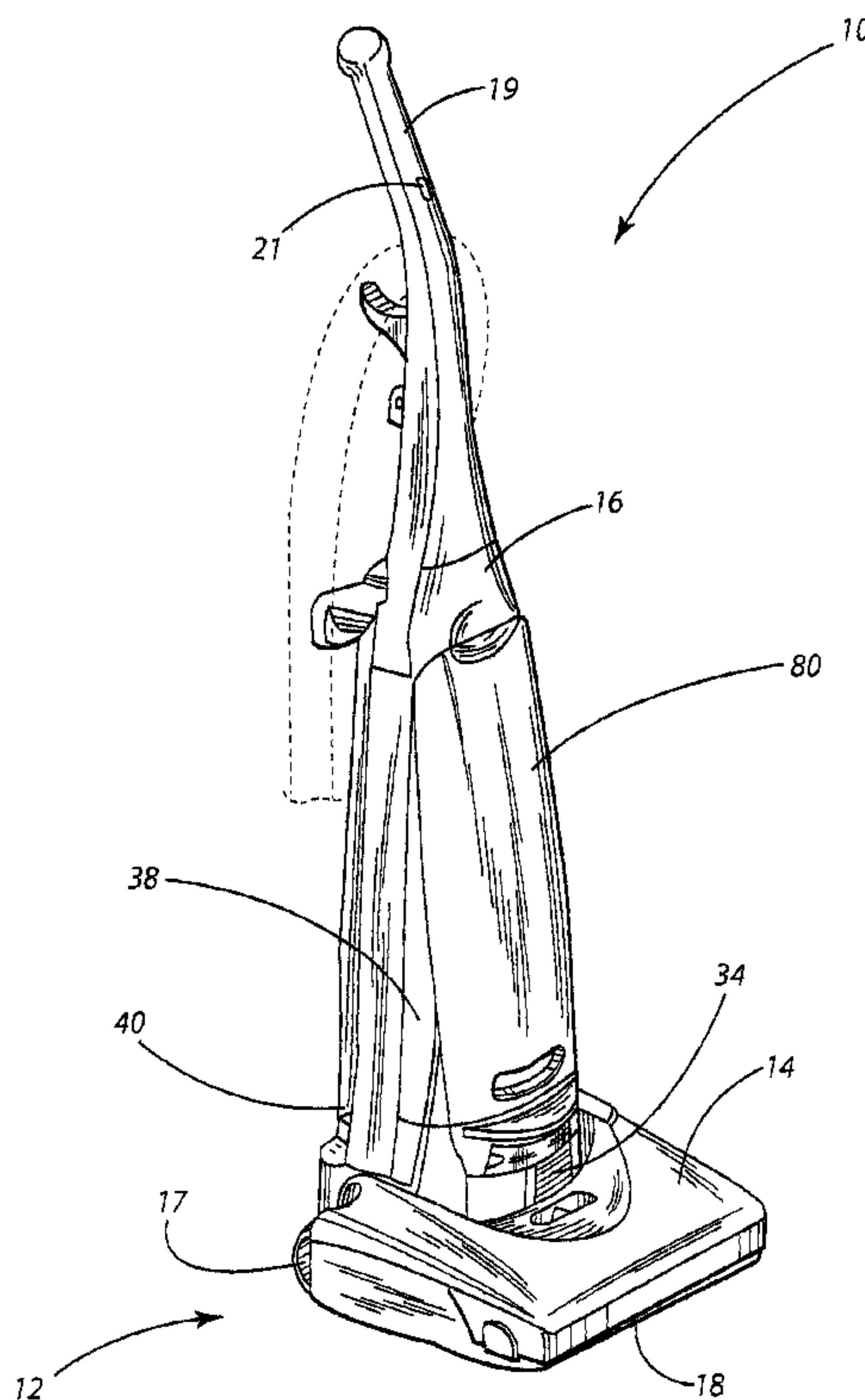

(22) Date de dépôt/Filing Date: 2006/07/12  
(41) Mise à la disp. pub./Open to Public Insp.: 2007/01/28  
(30) Priorité/Priority: 2005/07/28 (US11/191,736)

(51) Cl.Int./Int.Cl. *A47L 9/14* (2006.01),  
*A47L 5/28* (2006.01)  
(71) Demandeur/Applicant:  
PANASONIC CORPORATION OF NORTH AMERICA,  
US  
(72) Inventeurs/Inventors:  
MAYES, R. MICHAEL, US;  
DAVIS, RONALD E., US;  
DEVER, KERRY L., US;  
HITZELBERGER, J.ERIK, US  
(74) Agent: SMART & BIGGAR

(54) Titre : ASPIRATEUR EQUIPE D'UN ELEMENT A SAC COMPRENANT UNE CAGE A SAC  
(54) Title: VACCUM CLEANER EQUIPPED WITH BAG COMPONENT INCLUDING A BAG CAGE



(57) **Abrégé/Abstract:**

A vacuum cleaner includes a housing, a suction generator carried by the housing, a bag compartment and a bag cage. The bag compartment is defined by a bag compartment wall including an airflow inlet and an airflow outlet. The bag cage is received in the bag compartment. The bag cage defines a bag cavity that hold a filter bag in a position spaced from the bag compartment wall so as to maintain a clear airflow passage.

Abstract of the Disclosure

A vacuum cleaner includes a housing, a suction generator carried by the housing, a bag compartment and a bag cage. The bag compartment is defined by a bag compartment wall including an airflow inlet and an airflow outlet.

5 The bag cage is received in the bag compartment. The bag cage defines a bag cavity that hold a filter bag in a position spaced from the bag compartment wall so as to maintain a clear airflow passage.

## **VACUUM CLEANER EQUIPPED WITH BAG COMPARTMENT INCLUDING A BAG CAGE**

### Technical Field

The present invention relates generally to the floor care equipment field and, more particularly, to a vacuum cleaner equipped with a novel dirt containment or entrapment mechanism..

### Background of the Invention

A vacuum cleaner is an electrically powered, mechanical appliance utilized for the dry removal of dust and loose dirt from carpets, rugs, fabrics, bare floors and other surfaces. Vacuum cleaners have been widely  
5 utilized for years in domestic and industrial cleaning applications.

In operation, a pressure drop is utilized to force air entrained with loose dirt and dust into the nozzle of a vacuum cleaner. The dust and dirt laden air is then drawn through a bag which traps and retains the dirt. The air is then exhausted by electric fan through an additional filter to remove  
10 relatively fine particles. It is this fan that provides the air pressure drop or vacuum that provides the cleaning action.

It is only possible to maximize free airflow and thus cleaning ability by employing uniform airflow through the entire available surface area of

the filter bag: that is the area above the level of accumulated dirt and debris. However, an inherent problem in the design of current bag vacuum cleaners prevents the filter bag from maximizing its full volume and, accordingly, air power (i.e. suction and air velocity) drops off rapidly with material  
5 ingestion. Specifically two primary functional flaws combine to decrease cleaning efficiency.

First, the filter bag expands with airflow to contact the surrounding vacuum or bag chamber walls. As a consequence, no air gap or passage is maintained between the filter bag and the inner chamber wall surface. This  
10 functions to seal off airflow through the entire circumferential surface area of the filter bag. With no alternative pathway available, air is then forced to flow entirely through the bottom of the bag and any accumulated material therein. This decreases the total airflow and the motor efficiency.

Second, the vacuum chamber outlet or plenum mouth is typically  
15 undersized, requiring a sharp bend in the flow path from the outer periphery of the bag bottom resulting in increased flow resistance and back pressure. When considered together these two problems have a very significant adverse effect on the cleaning efficiency of the vacuum cleaner as the filter bag is filled with material.

20 The present invention addresses and resolves both of these problems. As a result, the vacuum cleaner of the present invention advantageously affords prolonged air power with progressive ingestion of material thus maximizing the capacity of the filter bag and the cleanability of the vacuum cleaner.

### Summary of the Invention

In accordance with the purposes of the present invention as described herein, a new and improved floor care appliance or vacuum cleaner is provided. The vacuum cleaner may take substantially any form including an upright vacuum cleaner, a canister vacuum cleaner or a handheld vacuum cleaner. The vacuum cleaner may be generally described as including a housing and a suction generator carried by the housing. In addition the vacuum cleaner includes a bag compartment wall defining a bag compartment in the housing. The bag compartment wall includes an airflow inlet and an airflow outlet. Still further, the vacuum cleaner includes a bag cage. The bag cage is received in the bag compartment. The bag cage defines a bag cavity. That bag cavity is spaced from the bag compartment wall so as to maintain an airflow passage or gap between the bag cavity and the bag compartment wall.

A filter bag is provided in the bag cavity. The filter bag includes an inlet connected to the airflow inlet in the bag compartment wall. More specifically, an inlet fitting projects through the bag compartment wall and defines the airflow inlet. The bag cage may be mounted to this inlet fitting. The bag compartment wall includes a front surface, a rear surface, a top surface, a bottom surface, a right side surface and a left side surface. In one possible embodiment the airflow inlet is provided in the rear surface and the airflow outlet is provided in the bottom surface.

The bag cage includes multiple openings allowing airflow from the bag cavity to the bag compartment. Typically the bag cage is greater than 50% open space for free airflow in substantially any direction.

The bag cavity has a first volume of between about 4.0 liter and about 7.5 liter and the bag compartment has a second volume of between

about 5.5 liter and about 10.5 liter. The volume of the bag cavity is between about 40 and about 80 percent of the volume of the bag compartment.

The bag cage functions to hold the filter bag in a position where the filter bag is spaced from the bag compartment wall. As a consequence an  
5 airflow passage is maintained between the bag cage and the bottom surface of the bag compartment wall. Further, the airflow passage is maintained between the bag cage (and the filter bag maintained therein) and at least one of the right side surface, left side surface, rear surface and front surface of the bag compartment wall. In one particularly useful embodiment, the  
10 airflow passage is maintained between the bag cage (and the filter bag contained therein) and all surfaces of the bag compartment wall. Preferably the airflow passage has a cross sectional area between the bag cage and the bag compartment wall of between about 38.0 cm<sup>2</sup> and about 90.0 cm<sup>2</sup>. Advantageously, the airflow passage allows free airflow that is unimpeded  
15 by the bag compartment wall from the entire surface of the bag above the level of accumulated dirt and debris within the bag to the airflow outlet leading from the bag compartment to the suction generator.

The airflow outlet has a cross sectional area of at least 13.0 cm<sup>2</sup> and typically between about 13.0 cm<sup>2</sup> and about 58.0 cm<sup>2</sup> so as to enable the  
20 suction generator to freely draw the air from the filter bag and thereby maintain good air power or suction air velocity for optimal cleaning efficiency at all times.

In accordance with yet another aspect of the present invention the airflow inlet has a cross sectional area of between about 4.5 cm<sup>2</sup> and about  
25 19.0 cm<sup>2</sup> to aid in achieving this beneficial result.

In accordance with yet another aspect of the present invention an upright vacuum cleaner is provided. The upright vacuum cleaner may be

more specifically defined as including a nozzle assembly having a suction inlet and a canister assembly pivotally connected to the nozzle assembly. In addition the upright vacuum cleaner includes a suction generator carried on one of the nozzle assembly and the canister assembly and a bag  
5 compartment wall defining a bag compartment on the canister assembly. The bag compartment wall includes an airflow inlet and an airflow outlet. Further the upright vacuum cleaner includes a bag cage received in the bag compartment. The bag cage defines a bag cavity. The bag cavity is spaced from the bag compartment wall so as to maintain an airflow passage  
10 between the bag cavity and the bag compartment wall.

In accordance with yet another aspect of the present invention, a canister vacuum cleaner is provided. The canister vacuum cleaner includes a nozzle assembly including a suction inlet and a canister housing. A flexible hose connects the nozzle assembly to the canister housing. In  
15 addition the canister vacuum cleaner includes a suction generator carried by the canister housing. A bag compartment wall defines a bag compartment in the canister housing. The bag compartment wall includes both an airflow inlet and an airflow outlet. A bag cage is received in the bag compartment. The bag cage defines a bag cavity. The bag cavity is spaced from the bag  
20 compartment wall so as to maintain an airflow passage between the bag cavity and the bag compartment wall.

In accordance with yet another aspect of the present invention, a method is provided for increasing the cleanability of a vacuum cleaner equipped with a filter bag. That method includes the step of positioning the  
25 filter bag in a bag cavity inside a bag compartment of the vacuum cleaner. Further the method includes the holding of the filter bag in a position spaced from a wall of the vacuum cleaner defining the bag compartment and the

maintaining of an airflow passage between the filter bag and that wall along a length of the filter bag so as to allow clean air flow around the filter bag within the bag compartment.

In the following description there is shown and described a preferred embodiment of the invention, simply by way of illustration of one of the modes best suited to carry out the invention. As it will be realized, the invention is capable of other different embodiments and its several details are capable of modification in various, obvious aspects all without departing from the invention. Accordingly, the drawings and descriptions will be regarded as illustrative in nature and not as restrictive.

#### Brief Description of the Drawing

The accompanying drawing incorporated in and forming a part of this specification illustrates several aspects of the present invention and together with the description serves to explain certain principles of the invention. In the drawing:

Figure 1 is a perspective view of one possible embodiment of the vacuum cleaner of the present invention;

Figure 2 is a detailed, exploded perspective view illustrating the relationship between the bag compartment, the bag cage and the filter bag;

Figure 3a is a detailed, transverse cross sectional and schematical view illustrating the airflow passage maintained between the bag cage, the filter bag held in the bag cage and the right side, left side, front and rear surfaces of the bag compartment wall;

Figure 3b is a detailed, longitudinal cross sectional and schematical view illustrating the airflow passage maintained between the bag cage and the right side, left side, top and bottom surfaces of the bag compartment



wall; and

Figure 4 is a perspective view of an alternative embodiment of the invention.

Reference will now be made in detail to the present preferred  
5 embodiment of the invention, an example of which is illustrated in the accompanying drawings.

#### Detailed Description of the Invention

Reference is now made to Figure 1 illustrating one possible  
embodiment of the vacuum cleaner 10 of the present invention. The  
10 illustrated embodiment is an upright vacuum cleaner 10.

The vacuum cleaner 10 includes a housing, generally designated by  
reference numeral 12, including a nozzle section or assembly 14 and a  
canister section or assembly 16. As is known in the art, the canister section  
16 is pivotally connected to the nozzle section 14 to aid the operator in  
15 manipulating the vacuum cleaner 10 back and forth across the floor.  
Wheels 17 (only one illustrated in Figure 1) carried on the housing 12 allow  
the vacuum cleaner 10 to be moved smoothly across the floor. As  
illustrated, the nozzle section 14 is equipped with a suction inlet 18. In the  
illustrated embodiment, the suction inlet 18 also includes a rotary agitator  
20 17.

As best illustrated in Figure 2, the canister section 16 houses a  
suction generator 22 (i.e. a fan and motor assembly) and a bag compartment  
24 that will be described in greater detail below. The canister section 16  
also includes a control handle 19 and an actuator switch 21 for controlling  
25 the operation of the vacuum cleaner 10 and thereby driving the rotary  
agitator 17 and the suction generator 22 as desired. In the illustrated

embodiment the actuator switch 21 comprises a series of touch controls.

During the cleaning operation the rotary agitator 17 brushes and beats dirt and debris from the nap of an underlying carpet being cleaned. The dirt and debris are then drawn by the suction generator 22 through the suction inlet 18, the airflow inlet 25, the filter bag 26 in the bag compartment 24 and the secondary filter 28 that is provided across the airflow outlet 30. Dirt and debris are collected in the filter bag 26 and fine debris is screened by the secondary filter 28. The airstream is then directed through the motor of the suction generator 22 to provide cooling before being routed through a final filter (not shown), to remove any carbon particles stripped from the brushes of the motor by the airstream, before exhausting the airstream through an exhaust port 34 into the environment.

As best illustrated in Figures 2 and 3, the canister section 16 includes two cooperating housing members or sections 38 and 40. The housing members 38 and 40 carry the wall 42 that defines the bag compartment 24. In the illustrated embodiment, the bag compartment wall 42 includes a top surface 44, a bottom surface 46, a right side surface 48, a left side surface 50, a front surface 52 and a rear surface 54. As illustrated, the front surface 52 may be formed by the access door 80 of the canister housing member 38 while the rear surface 54 may be formed by the housing member 40. The remaining surfaces 44, 46, 48 and 50 of the bag compartment wall 42 may be formed by cooperating segments projecting from both the housing members 38, 40 which meet and form a substantially airtight seal.

An inlet fitting 60 in the rear surface 54 of the bag compartment wall 42 defines the airflow inlet 25 into the bag compartment 24. The airflow outlet 30 is provided in the bottom surface 46 of the bag compartment wall 42. A secondary filter 28, such as a fine screen, polymeric filter media or

the like, extends across the airflow outlet 30 so as to capture any fine dirt and debris that might pass through the filter bag 26 in the bag compartment 24 and thereby prevent its passage into the motor of the suction generator 22.

5           A bag cage, generally designated by reference numeral 64, defines a cavity 66 for receiving and holding the filter bag 26. In the illustrated embodiment, the bag cage 64 includes a first section 68, secured to the inlet fitting 60 and the housing section 38 by means of struts 61, and a second removable access section 70 which may be selectively secured to the first  
10           section 68 by resilient clips 71.

          As should be appreciated, the bag cage 64 is fully received in the bag compartment 24. The cavity 66 defined by the bag cage 64 has a first volume of between about 4.0 liter and about 7.5 liter and the bag compartment 24 has a second volume of between about 5.5 liter and about  
15           10.5 liter. Typically, the volume of the bag cavity 66 is between about 40 and about 80 percent of the volume of the bag compartment 24.

          As best illustrated in Figures 3a and 3b, the bag cage 64 is mounted in the bag compartment 24 so as to provide an airflow passage 72 completely surrounding the filter bag 26 between the bag cage 64 and the  
20           surfaces 44, 46, 48, 50, 52 and 54 of the bag compartment wall 42. Typically the air passage has a width between the bag cage 64 and the bag compartment wall 42 of between about 6.0 mm and about 32.0 mm at all points.

          During vacuum cleaner operation, as air entrained with dirt and  
25           debris is drawn by the suction generator 22 from the suction inlet 18 through the airflow inlet 25 into the filter bag 26, the filter bag 26 expands and is held up against the bag cage 64. The bag cage 64 prevents the filter

bag 26 from expanding into engagement with any surface 44, 46, 48, 50, 52 and 54 of the bag compartment wall 42 thereby positively maintaining the airflow passage 72 all the way around the filter bag. Advantageously, the airflow passage 72 provides a continuously free and open air path for clean air to be drawn quickly through the entire circumferential surface area of the filter bag 26 even as the filter bag fills with dirt and debris. As a consequence, the suction generator 22 is never forced to draw air through the dirt and debris collecting in the bottom of the filter bag 26. As such, airflow is not significantly diminished by the collected dirt and debris and cleaning efficiency is maintained at high levels even as the filter bag 26 fills. Further, suction air velocity remains high at all times even as the filter bag 26 fills with dirt and debris.

In contrast, in bag vacuum cleaners of prior art design, the filter bag has a tendency to expand into engagement with the sidewalls of the bag compartment thereby effectively sealing and substantially preventing the free passage of air through the sidewall of the filter bag. As a consequence, the air being drawing through the vacuum cleaner by the suction generator is forced to travel through the dirt and debris in the filter bag toward the air flow outlet. The dirt and debris interferes with the free passage of the air thereby reducing the air velocity and, accordingly the cleaning power of the vacuum cleaner as the air bag fills with the dirt and debris. This problem is effectively avoided utilizing the cooperating bag cage 64 and the bag compartment 24 of the vacuum cleaner of the present invention.

It should be appreciated that the bag cage 64 is greater than 50% open space in order to promote free airflow. Further, the volume  $V_1$  of the bag cavity 66, the volume  $V_2$  of the bag compartment 24, the cross sectional area  $A_i$  of the airflow inlet 25, the cross sectional area  $A_p$  of the portion of

the airflow passage 72 between the bag cage and the bag compartment wall and the cross sectional area  $A_o$  of the airflow outlet are all designed to function together in order to insure clean and efficient airflow from the time the filter bag is empty to the time it is full and ready for changing.

5           When it becomes necessary to service the filter bag 26, the access door 80 of the canister housing member 38 is removed from the vacuum cleaner 10 so as to expose the access section 70 of the bag cage 64. The access section 70 is then removed from the first section 68 of the bag cage 64 so as to allow the operator access to the filter bag 26. The full filter bag 10 26 is then pulled out of the bag compartment 24 and disposed of in a garbage receptacle. A new filter bag 26 is then inserted into the bag cage 64 by fitting the inlet 27 of the filter bag 26 over the inlet fitting 60. The access section 70 is then repositioned on the first section 68 and held in place by the resilient fasteners 71 providing a snap fit. Next the door 80 is 15 replaced on the vacuum cleaner 10 so as to properly mate with the section 38. The vacuum cleaner 10 is then once again ready for use.

The foregoing description of a preferred embodiment of the present invention has been presented for purposes of illustration and description. It is not intended to be exhaustive or to limit the invention to the precise form 20 disclosed. Obvious modifications or variations are possible in light of the above teachings. For example, the canister vacuum cleaner illustrated in Figure 4 and generally designated by reference numeral 100 may be equipped with a bag compartment 24 and bag cage 64 as described above with respect to the Figure 1 embodiment. Such a canister vacuum cleaner 25 100 includes a nozzle assembly 102 connected by a flexible dirty air hose 106 to a canister assembly 104. The nozzle assembly 102 may or may not be equipped with a rotary agitator. The canister assembly 104 carries the

bag compartment 24 that holds the bag cage, and the associated suction generator. An access door 108 allows the operator to access the bag cage and change the filter bag.

The embodiment was chosen and described to provide the best  
5 illustration of the principles of the invention and its practical application to  
thereby enable one of ordinary skill in the art to utilize the invention in  
various embodiments and with various modifications as are suited to the  
particular use contemplated. All such modifications and variations are  
within the scope of the invention as determined by the appended claims  
10 when interpreted in accordance with the breadth to which they are fairly,  
legally and equitably entitled. The drawings and preferred embodiments do  
not and are not intended to limit the ordinary meaning of the claims and  
their fair and broad interpretation in any way.

What is claimed

1. A vacuum cleaner, comprising:
  - a housing;
  - a suction generator carried by said housing;
  - a bag compartment wall defining a bag compartment in said5 housing, said bag compartment wall including an airflow inlet and an airflow outlet; and
  - a bag cage received in said bag compartment, said bag cage defining a bag cavity, said bag cavity being spaced from said bag compartment wall so as to maintain an airflow passage between said bag10 cavity and said bag compartment wall.
2. The vacuum cleaner of claim 1 further including a filter bag in said bag cavity.
3. The vacuum cleaner of claim 2, wherein said filter bag includes an inlet connected to said airflow inlet.
4. The vacuum cleaner of claim 1, wherein said bag cage includes multiple openings allowing airflow from said bag cavity to said bag compartment.
5. The vacuum cleaner of claim 1, wherein said bag compartment wall includes a front surface, a rear surface, a top surface, a bottom surface, a right side surface and a left side surface.

6. The vacuum cleaner of claim 5, wherein said airflow inlet is in said rear surface and said airflow outlet is in said bottom surface.
7. The vacuum cleaner of claim 6, wherein a secondary filter is provided across said airflow outlet.
8. The vacuum cleaner of claim 5, wherein an inlet fitting projects through said bag compartment wall and defines said airflow inlet.
9. The vacuum cleaner of claim 8, wherein said bag cage is mounted to said inlet fitting.
10. The vacuum cleaner of claim 5, wherein said airflow passage is maintained between said bag cage and said bottom surface of said bag compartment wall.
11. The vacuum cleaner of claim 10, wherein said airflow passage is maintained between said bag cage and at least one of said right side surface, said left side surface, said rear surface and said front surface of said bag compartment wall.
12. The vacuum cleaner of claim 10, wherein said airflow passage is maintained between said bag cage and said right side surface, said left side surface, said front surface and said rear surface of said bag compartment wall.



13. The vacuum cleaner of claim 12, wherein said airflow passage is maintained between said bag cage and said top surface of said bag compartment wall.
14. The vacuum cleaner of claim 13, wherein said airflow passage has a cross sectional area between said bag cage and said bag compartment wall of between about 38.0 cm<sup>2</sup> and about 90.0 cm<sup>2</sup>.
15. The vacuum cleaner of claim 1, wherein said bag cavity has a first volume and said bag compartment has a second volume wherein said first volume is between about 40 and about 80 percent of said second volume.
16. The vacuum cleaner of claim 1, wherein said bag cavity has a first volume of between about 4.0 liter and about 7.5 liter and said bag compartment has a second volume of between about 5.5 liter and about 10.5 liter.
17. The vacuum cleaner of claim 16, wherein said airflow inlet has a cross sectional area of between about 4.5 cm<sup>2</sup> and about 19.0 cm<sup>2</sup> and said airflow outlet has a cross sectional area of between about 13.0 cm<sup>2</sup> and about 58.0 cm<sup>2</sup>.
18. The vacuum cleaner of claim 1, wherein said bag cage is greater than 50% open space for free airflow.

19. An upright vacuum cleaner, comprising:

a nozzle assembly having a suction inlet;

a canister assembly pivotally connected to said nozzle assembly;

a suction generator carried on one of said nozzle assembly and

5 said canister assembly;

a bag compartment wall defining a bag compartment in said  
canister assembly, said bag compartment wall including an airflow inlet and an  
airflow outlet; and

10 a bag cage received in said bag compartment, said bag cage  
defining a bag cavity, said bag cavity being spaced from said bag compartment  
wall so as to maintain an airflow passage between said bag cavity and said bag  
compartment wall.

20. The upright vacuum cleaner of claim 19 further including a rotary  
agitator carried on said nozzle assembly in said suction inlet.

21. The upright vacuum cleaner of claim 20, wherein said suction inlet is in  
fluid communication with said airflow inlet and said airflow outlet is in fluid  
communication with said suction generator.

22. The upright vacuum cleaner of claim 19, further including a filter bag in  
said bag cavity.

23. A canister vacuum cleaner, comprising:

a nozzle assembly including a suction inlet;

a canister housing;

a flexible hose connecting said nozzle assembly to said canister housing;

a suction generator carried by said canister housing;

5 a bag compartment wall defining a bag compartment in said canister housing, said bag compartment wall including an airflow inlet and an airflow outlet; and

10 a bag cage received in said bag compartment, said bag cage defining a bag cavity, said bag cavity being spaced from said bag compartment wall so as to maintain an airflow passage between said bag cavity and said bag compartment wall.

24. A method for increasing cleanability of a vacuum cleaner equipped with a filter bag, comprising:

positioning said filter bag in a bag cavity inside a bag compartment of a vacuum cleaner;

5 holding said filter bag in a position spaced from a wall of said vacuum cleaner defining said bag compartment and maintaining an airflow passage between said filter bag and said wall along a length of said filter bag so as to allow clean air flow around said filter bag within said bag compartment.

25. The method of claim 24 further including maintaining airflow through substantially the entire surface area of said filter bag thereby allowing maximum airflow through any portion of said surface area that may exist above a level of accumulated dirt and debris in said filter bag at any time.

Smart & Biggar  
Ottawa, Canada  
Patent Agents

*Fig. 1*

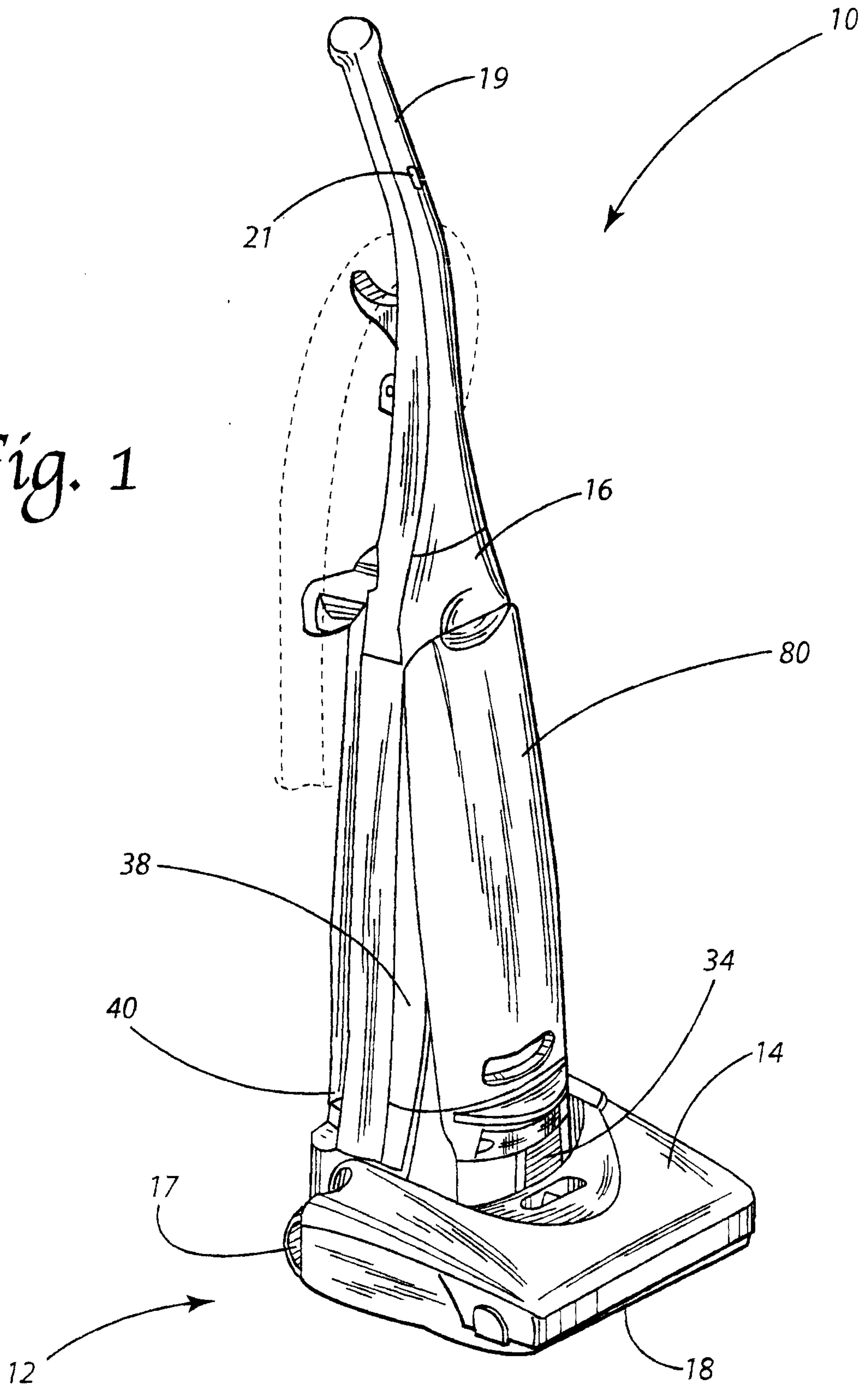

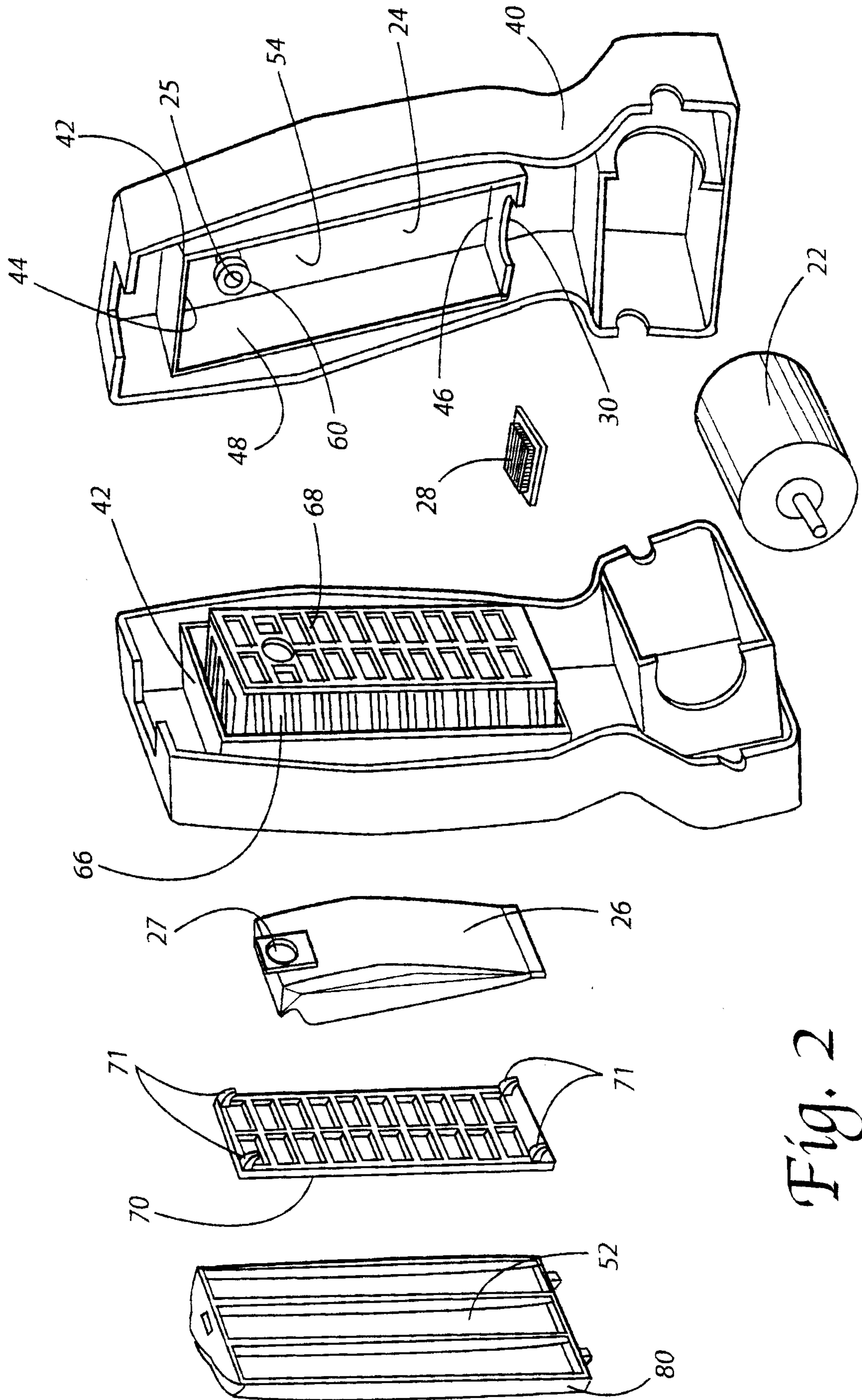

Fig. 2

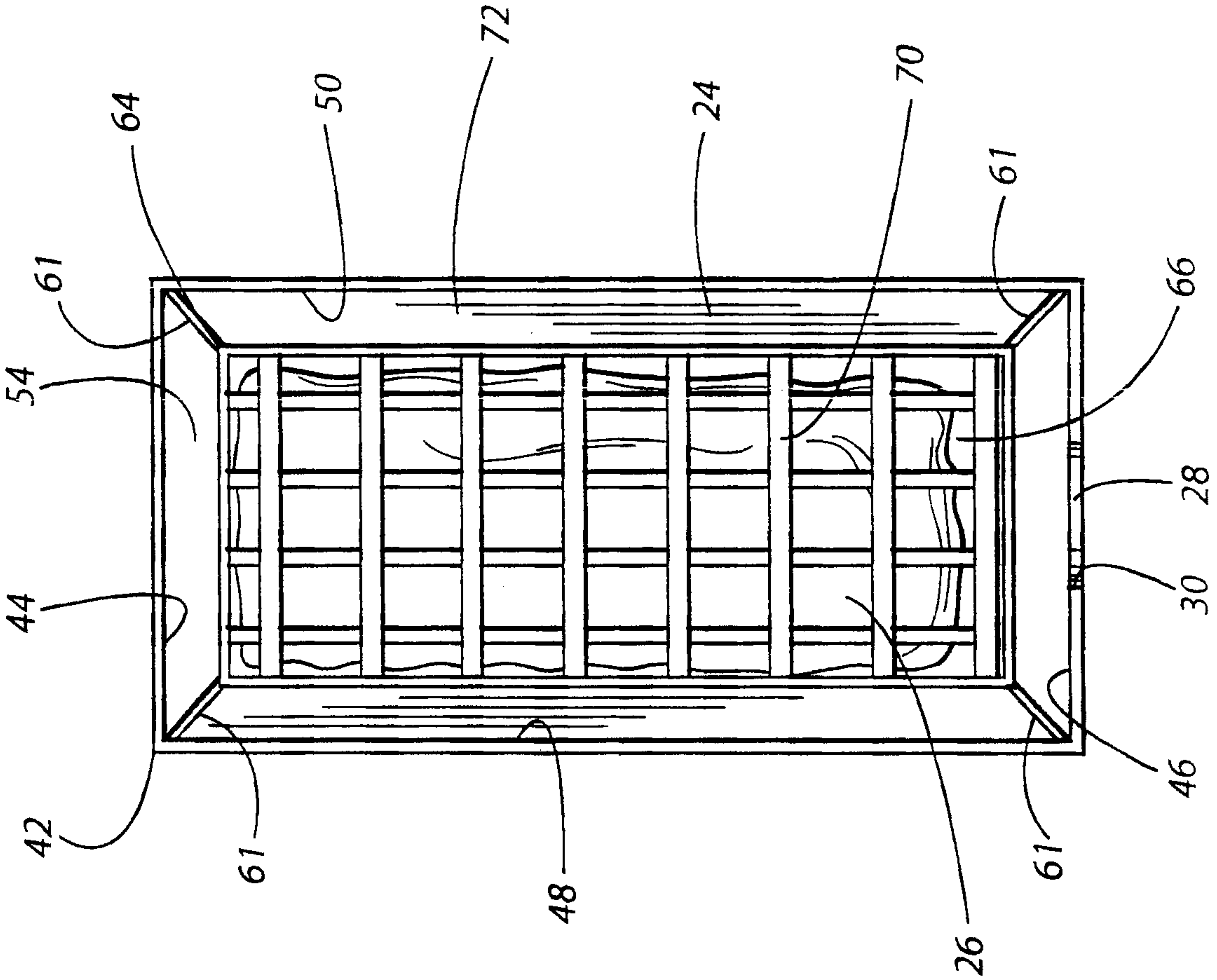

Fig. 36

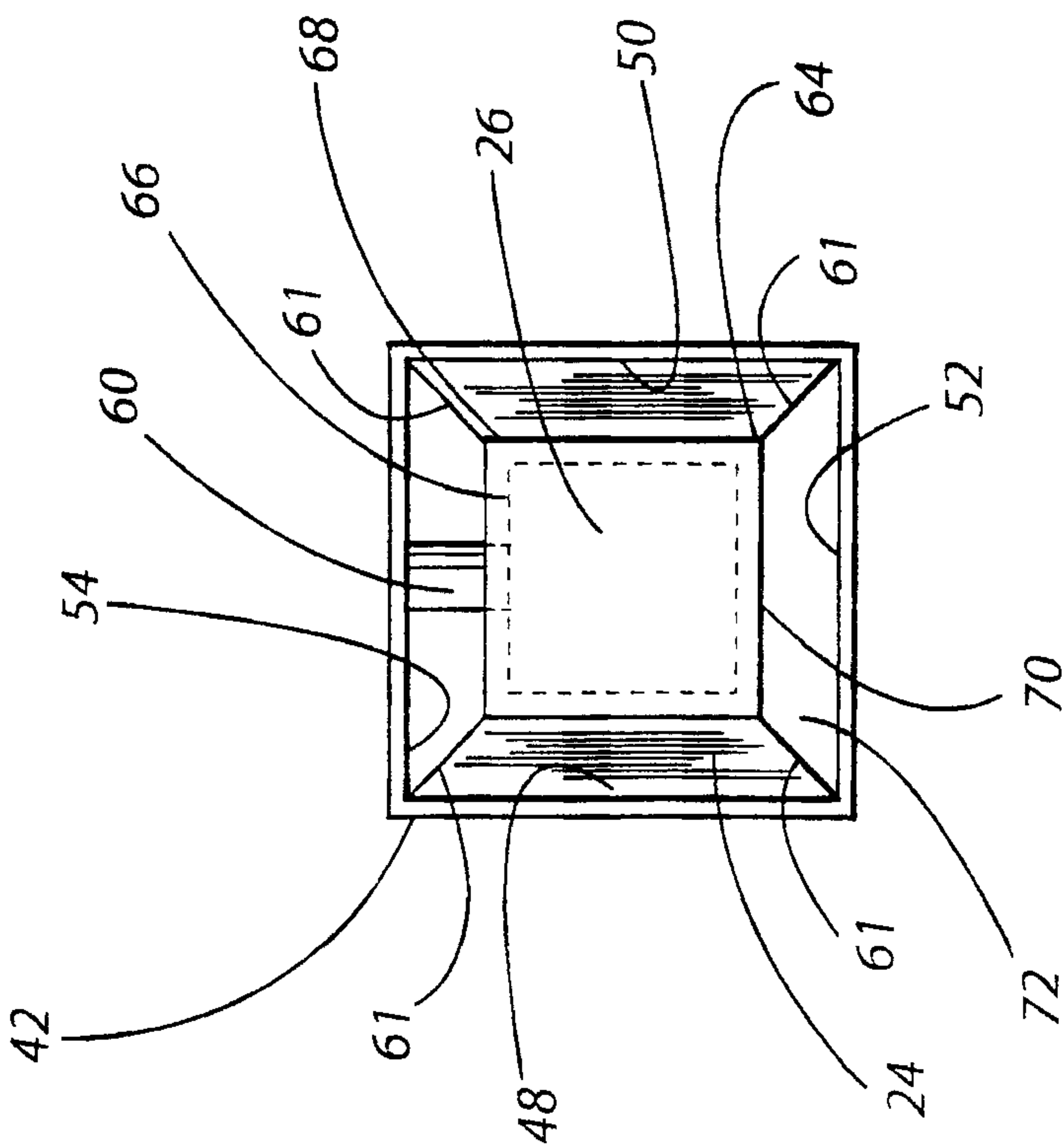

Fig. 3a

Fig. 4

