

(19) (KR)
(12) (Y1)

(51) 。 Int. Cl. ⁷ (45) 2001 11 22
F16B 37/10 (11) 20 - 0250964
(24) 2001 10 06

(21) 20 - 2001 - 0022361
(22) 2001 07 24

(73) 409 - 1

(72) 409 - 1

(74)
:
가 :

(54)

가 ,
(2) ,
(23) 가 가 (22) (21), (21)
(24) (20) , (20) (21) (21)
(31) ,
(24) (32) 2 (30) ,
(線材) 가 (24) (24) (32)
(40) .

, , ,

1

2

3

4

5 a)

b)

c)

*

*

2; 20;

21; 22;가

23; 24;

30; 32;

40; 3;

가

가

가

(四角)

가

가
 가
 가

가

1 가 , 2
 , 4 , 3 , 5 a)
 가 , b)
 , c)
 (2) 1 3 ,
 (20) ,
 (20) (21) 2 (30) ,
 (20) (30) (40) .
 (20) (30) (21) 가 (22) ,
 , (21) (30)
 (21) (30) (23) 가 .
 (20) (21) (30) (40)
 (24) (21)

1 2 (20) (21) (30)

2 (21) (20) (24) (31) (40) (32)

(20) (30) (40) (線材) 가

(20) (24) (30) (32) (30)

(20) (21) (2) 3 2 (30) (32)

(20) (24) (32) (24) (40)

(20) (30) (40) (24) 4

(20) (30) (2) (2) ,

5 a), b) (30) (31) (3)

(50) 가 가

가 (2) (3)

(2) 가 5 c) (20)

(40) (30) (20)가

30) (20) (30) (20)가 (40) (20) (30) (3) (

(2)

(2) ,

가 가 , 가

(57)

1.

;

(2) ,

(23) 가
(24)

가 (22)
(20) ,

(21),

(21)

(20) (21)

(21)

(31) ,

(24)

(32)

2

(30) ,

(線材) 가
(40)

(24)

(32)

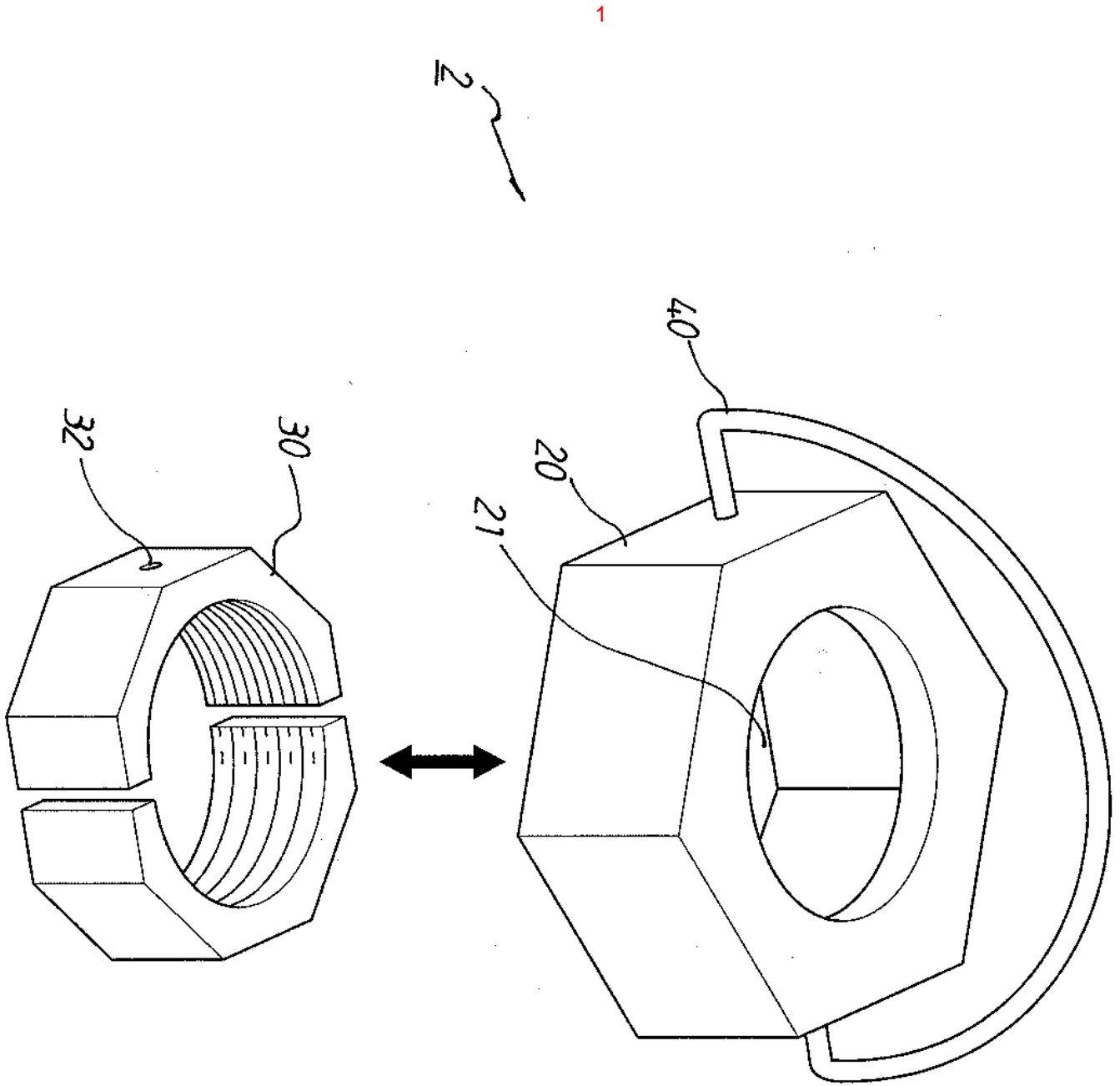

2

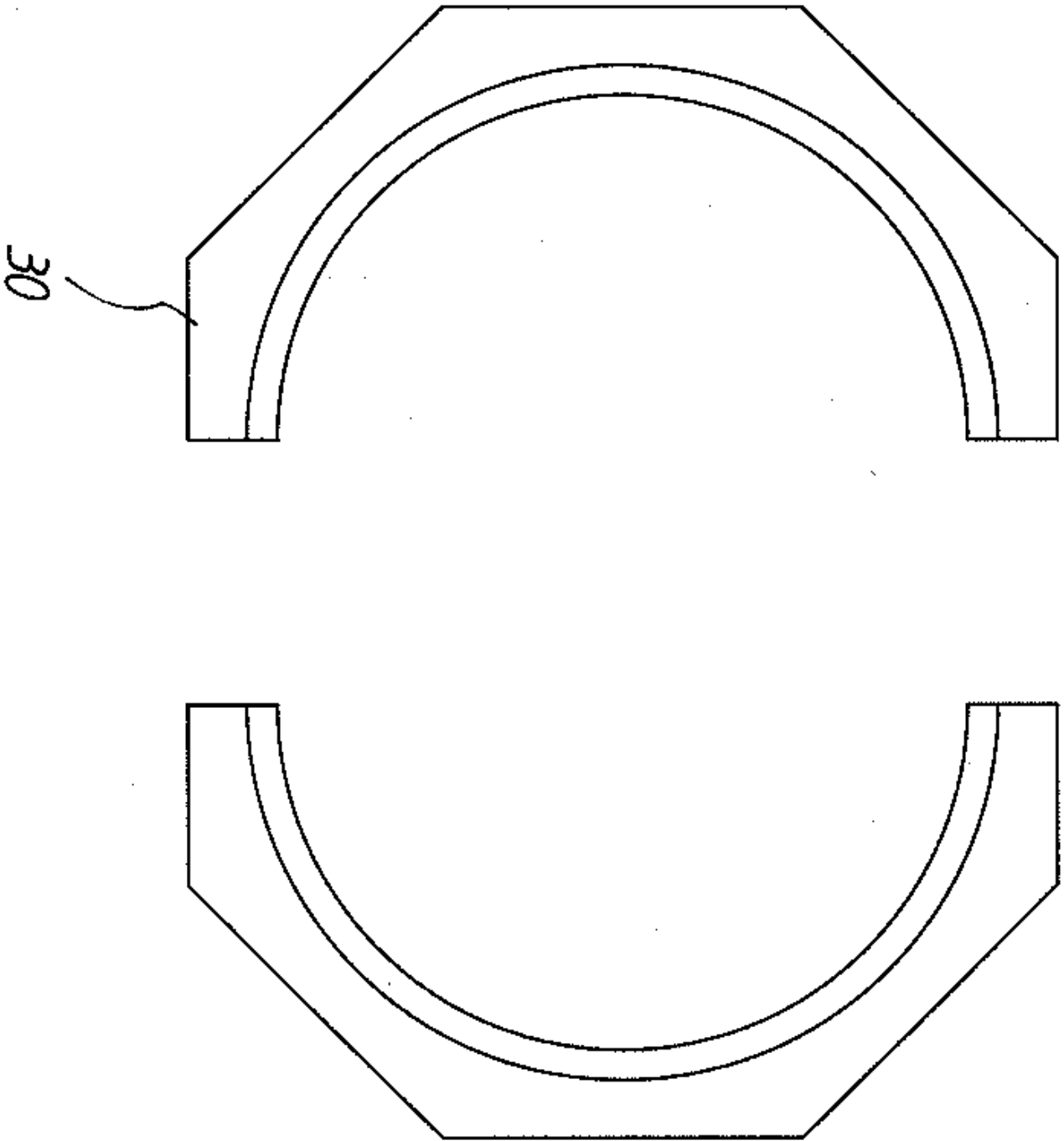

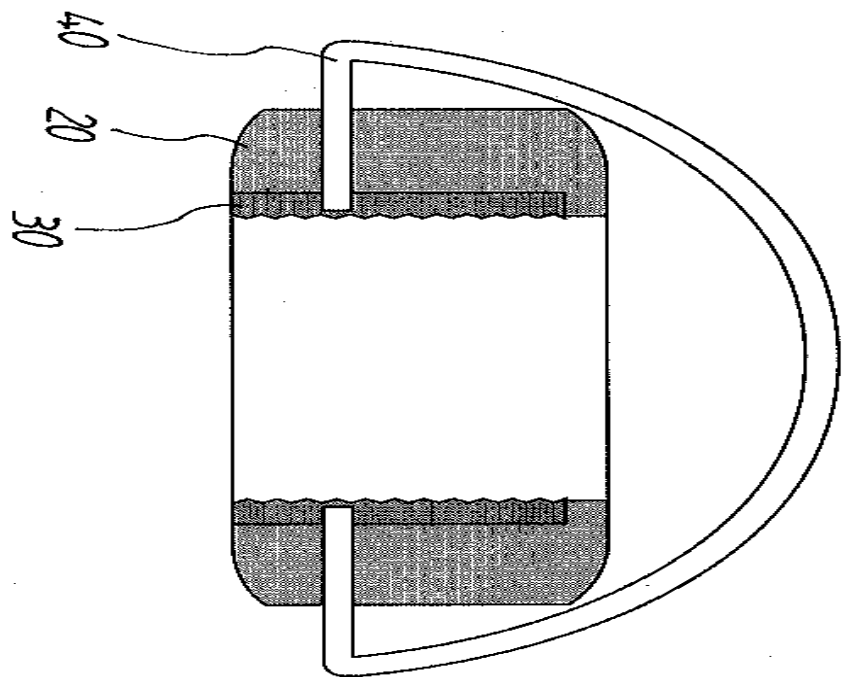
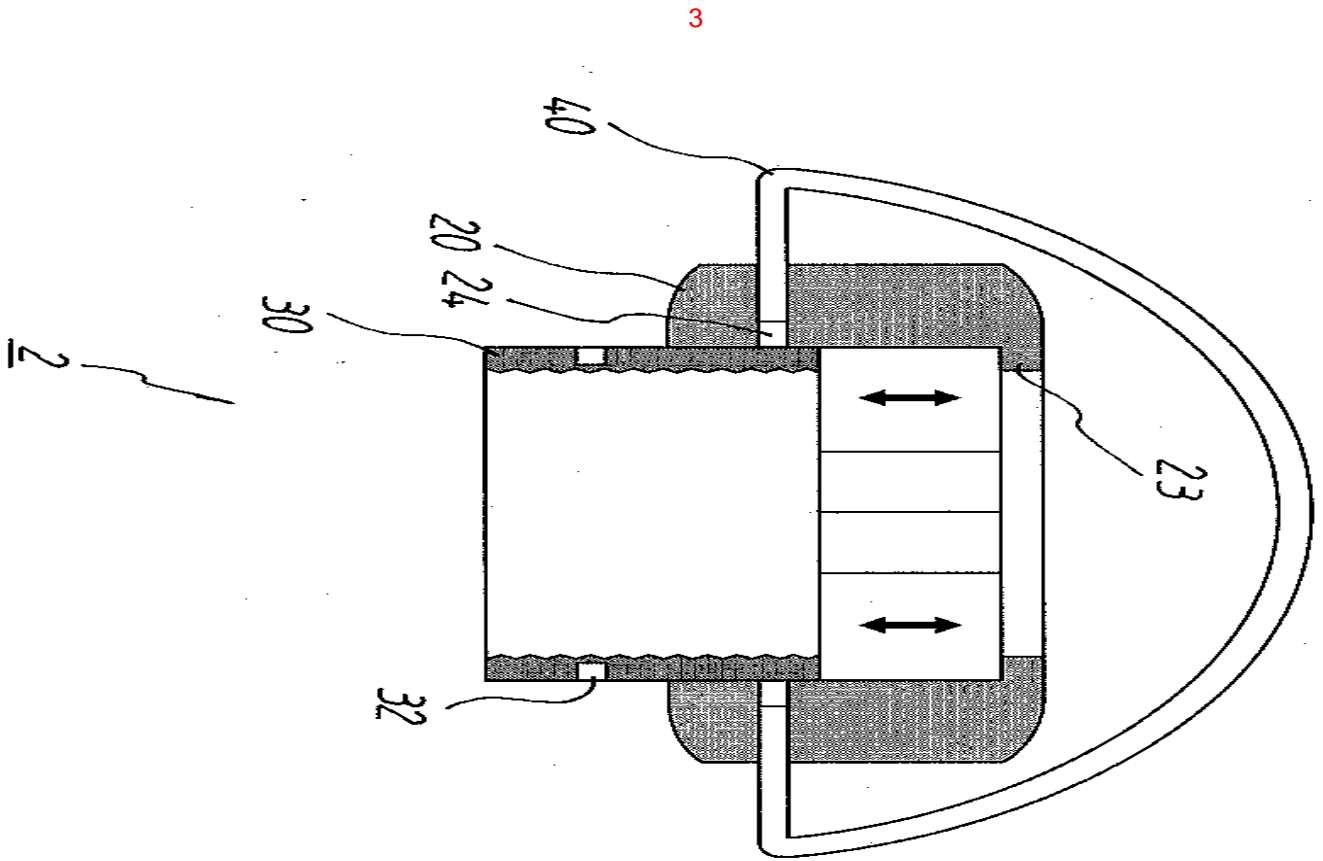

4

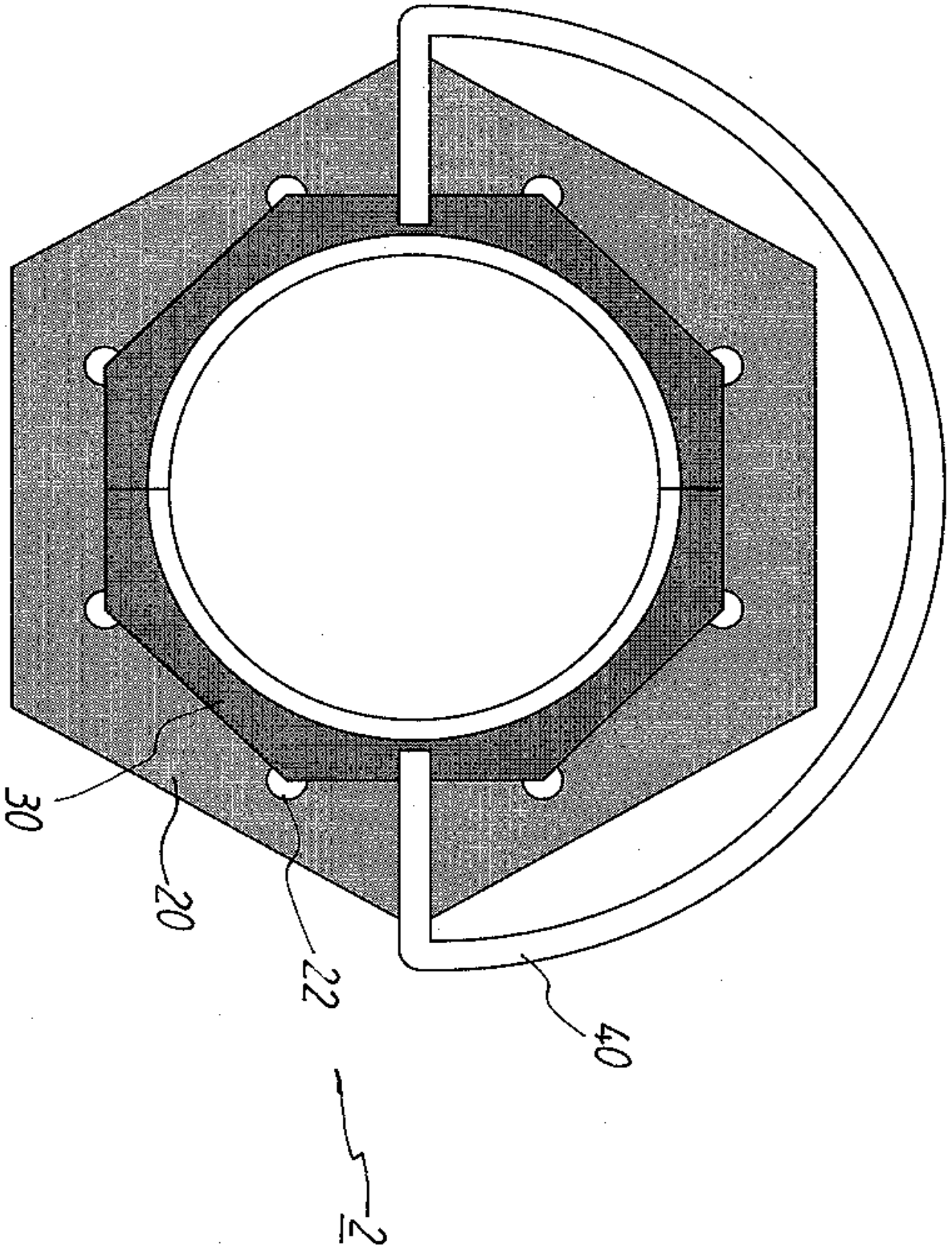

[a]

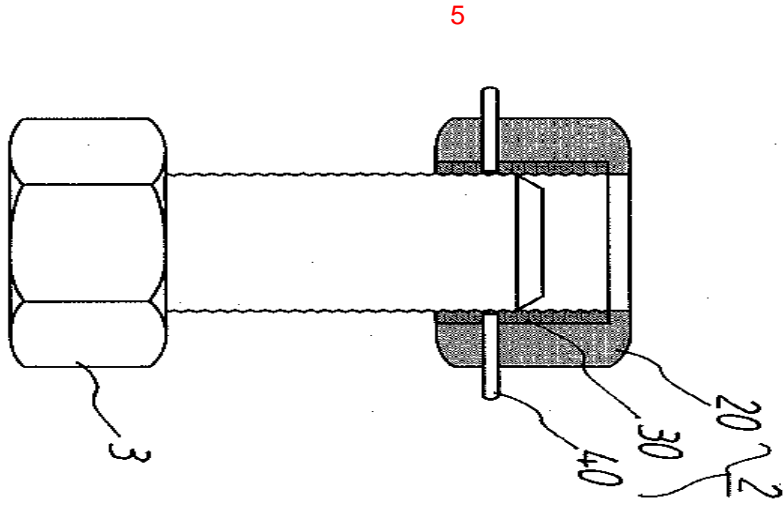

[b]

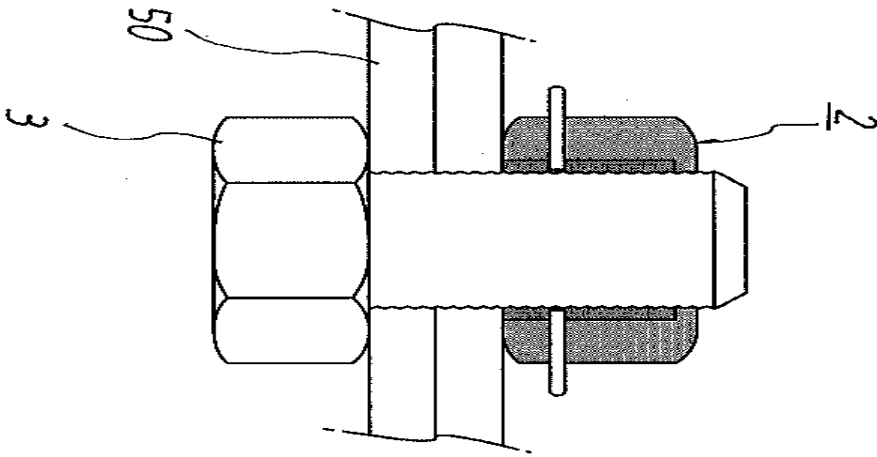

[c]

