

(19)



(11)

EP 2 213 076 B1

(12)

EUROPEAN PATENT SPECIFICATION

(45) Date of publication and mention of the grant of the patent:
12.07.2017 Bulletin 2017/28

(51) Int Cl.:
H04L 29/08 (2006.01)

(21) Application number: **08807928.0**

(86) International application number:
PCT/IB2008/054128

(22) Date of filing: **08.10.2008**

(87) International publication number:
WO 2009/050617 (23.04.2009 Gazette 2009/17)

(54) METHOD AND SERVICE PROVIDER FOR MANAGING EXPIRED OR CONSUMED APPLICATIONS BEING STORED IN MOBILE COMMUNICATION DEVICES

VERFAHREN UND DIENSTANBIETER ZUR VERWALTUNG VON ABGELAUFENEN ODER VERBRAUCHTEN ANWENDUNGEN, DIE IN MOBILKOMMUNIKATIONSGERÄTEN GESPEICHERT SIND

PROCÉDÉ ET FOURNISSEUR DE SERVICES POUR GÉRER DES APPLICATIONS EXPIRÉES OU UTILISÉES, STOCKÉES DANS DES DISPOSITIFS DE COMMUNICATION SANS FIL

(84) Designated Contracting States:
AT BE BG CH CY CZ DE DK EE ES FI FR GB GR HR HU IE IS IT LI LT LU LV MC MT NL NO PL PT RO SE SI SK TR

- **AZOULAI, Jonathan**
A-1102 Vienna (AT)
- **LEMONNIER, Vincent**
A-1102 Vienna (AT)

(30) Priority: **15.10.2007 EP 07291255**

(74) Representative: **Hardingham, Christopher Mark**
NXP SEMICONDUCTORS
Intellectual Property Group
Abbey House
25 Clarendon Road
Redhill, Surrey RH1 1QZ (GB)

(43) Date of publication of application:
04.08.2010 Bulletin 2010/31

(73) Proprietor: **NXP B.V.**
5656 AG Eindhoven (NL)

(56) References cited:
WO-A-2007/068991 US-A1- 2004 235 450
US-A1- 2007 156 436

(72) Inventors:
• **CORDA, Alexandre**
A-1102 Vienna (AT)

EP 2 213 076 B1

Note: Within nine months of the publication of the mention of the grant of the European patent in the European Patent Bulletin, any person may give notice to the European Patent Office of opposition to that patent, in accordance with the Implementing Regulations. Notice of opposition shall not be deemed to have been filed until the opposition fee has been paid. (Art. 99(1) European Patent Convention).

Description

FIELD OF THE INVENTION

[0001] The invention relates to a method for managing expired or consumed applications being stored in mobile communication devices.

[0002] The invention further relates to a computer program product directly loadable into the memory of a mobile communication device, comprising software code portions for performing the steps of a method according to the first paragraph when said product is run on the device.

[0003] The invention further relates to a mobile communication device being adapted to process the computer program product mentioned in the above paragraph.

[0004] The invention further relates to a Service Provider.

BACKGROUND OF THE INVENTION

[0005] There are mobile communication devices known which contain memory devices having unique memory device identifications, e.g. the MIFARE® classic family, developed by NXP Semiconductors, a contactless smart card IC operating in the 13.56 MHz frequency range with read/write capability. Recently, secure memory elements have been developed which are memory devices providing enhanced security features, particularly for the use in mobile phones and other mobile communication devices with Near Field Communication (NFC) capabilities. Said secure memory elements are also known as "Smart Cards". One of the leading representatives of these secure memory elements is the SmartMX (Memory extension) smart card family that has been designed by NXP Semiconductors for high-security smart card applications requiring highly reliable solutions, with or without multiple interface options. Key applications are e-government, banking / finance, mobile communications and advanced public transportation. SmartMX architecture combines coprocessors for RSA, ECC, DES and AES and enables implementation of operating systems including Java Open Platform and MULTOS. The ability of SmartMX cards to run the MIFARE protocol concurrently with other contactless transmission protocols implemented by the User Operating System enables the combination of new services and existing applications based on MIFARE (e.g. ticketing) on a single Dual Interface controller based smart card. SmartMX cards are able to emulate MIFARE Classic devices and thereby makes this interface compatible with any installed MIFARE Classic infrastructure. The contactless interface can be used to communicate via any protocol, particularly the MIFARE protocol and self defined contactless transmission protocols. SmartMX enables the easy implementation of state-of-the-art operating systems and open platform solutions including JCOP (the Java Card Operating System) and offers an optimized

feature set together with the highest levels of security.

[0006] Service Providers like banks, public transport companies, loyalty programs owners etc. provide contactless services to customers who are defined as persons using the mobile communication devices, e.g. NFC mobile phones, for mobile communications and contactless services. These contactless services comprise the provision of transport passes, cinema tickets, coupons, etc. which can be subsumed by the generic terms "applications" and "services". In the following description the term "application" will be used which has to be understood in a broad sense.

[0007] A customer buys applications for instance by ordering them from the website of a Service Provider. In the course of the purchasing procedure the customer inputs a unique identification number of his/her communication device, e.g. the telephone number of a NFC mobile phone, so that the Service Provider knows unambiguously where to send the application.

[0008] Then the Service Provider transmits the application to the customer's mobile communication device via any communication channel, e.g. the Over The Air (OTA) transport services of a Mobile Network Operator to which the customer is subscribed. Alternatively, the Service Provider communicates indirectly with the mobile communication device via a Trusted Service Manager which securely distributes and manages the Service Provider's applications and transmits them to the mobile communication device. The Trusted Service Manager does not participate in the transaction stage of the applications, thus ensuring that the Service Provider's business models are not disrupted. Trusted Service Managers can be managed by one or a plurality of Mobile Network Operators, or by independent Trusted Third Parties.

[0009] When the applications are received by the mobile communication device they are stored in a secure memory element of the mobile communication device and can be consumed by the customer by positioning the mobile communication device within the range of transmission of a reading device which reads and processes the application in an appropriate manner, e.g. by giving the user access to an entrance of a concert hall. After the applications have been consumed or expired they have to be deleted from the memory element in order to free memory space for future applications.

[0010] However, deleting the expired applications from the memory element is problematic if the customer wants to keep a trace (could be a receipt) of the applications that he/she has consumed. The same problem arises if the customer wants to acquire a collector object from the applications consumed (for instance if the applications corresponds to a concert ticket).

[0011] WO2007/068991A1 relates to a method, device, and system for network-based remote control over contactless secure storages. It discloses that application related code sections may be stored in a secure memory element, and may be deleted from the secure memory element upon a command of the remote, secure storage

maintenance centre.

[0012] US 2004/0235450 discloses a mobile communication device with security mechanisms for enabling wireless personal information transfer with increased security. It discloses providing an electronic receipt to the user's mobile communication device.

OBJECT AND SUMMARY OF THE INVENTION

[0013] It is an object of the invention to provide a mechanism that enables the customer to keep applications that have been consumed or expired or representations of them and yet to delete the applications from the memory element of his/her mobile communication device. This is achieved by a method according to claim 1.

[0014] In order to achieve the object defined above, with a computer program product according to the invention characteristic features are provided so that a computer program product according to the invention is directly loadable into the memory of a mobile communication device and comprising software code portions for performing the steps of a method according to the invention when said product is run on the mobile communication device.

[0015] In order to achieve the object defined above, a mobile communication device according to the invention comprises an arithmetic-logic unit and a memory and processes the computer program product according to the above paragraph.

[0016] The characteristic features according to the invention provide the advantage that even when an expired or consumed application is deleted from the memory element of a mobile communication device the customer can keep a representation of the applications that he/she has consumed.

[0017] The measures as claimed in claim 2 provide the advantage that the customer has immediately access to the requested representation of the expired application.

[0018] The measures as claimed in claim 3 provide the advantage that free memory space is provided for installing future applications in the memory element.

[0019] The measures as claimed in any of claim 4 to claim 6 list different preferred formats of representations of expired applications.

[0020] The measures as claimed in claim 7 or claim 8, respectively, provide the advantage that making representations available to the customer is handled by the Service Provider which has originally generated the application for the customer. This embodiment of the application enables the customer to choose among different formats of representations of the expired applications and different channels through which he can receive the representations.

[0021] The aspects defined above and further aspects of the invention are apparent from exemplary embodiments to be described hereinafter and are explained with reference to these exemplary embodiments.

BRIEF DESCRIPTION OF THE DRAWINGS

[0022] The invention will be described in more detail hereinafter with reference to exemplary embodiments. However, the invention is not limited to these exemplary embodiments.

Fig. 1 shows a schematic diagram of a system for providing contactless services from Service Providers to mobile communication devices.

Fig. 2 and Fig. 3 show schematic flow charts of a first embodiment of a method for managing expired or consumed applications according to the present invention.

Fig. 4 shows a schematic flow charts of a second embodiment of a method for managing expired or consumed applications according to the present invention.

DESCRIPTION OF EMBODIMENTS

[0023] Fig. 1 shows a schematic diagram of a system for providing contactless services to mobile communication devices MOB. The system comprises a Service Provider SP (it should be noted that the number of Service Providers is not limited), a Mobile Network Operator MNO providing the full range mobile services, particularly UICC and NFC terminals plus Over The Air (OTA) transport services, and a mobile communication device MOB representing an unlimited number of mobile communication devices. The mobile communication device MOB belongs to a customer CS who is a subscriber of the Mobile Network Operator MNO. Let us assume that over the time the customer has ordered a number of NFC (Near Field Communication) applications app1, app2 ... appx, e.g. tickets, transport passes and so on. The Service Provider SP has transmitted the applications app1, app2 ... appx either directly to the customer's mobile communication device MOB via the Over The Air transport services of the Mobile Network Operator MNO, or indirectly by sending them to a Trusted Service Manager TSM which then has forwarded the applications app1, app2 ... appx to the mobile communication device MOB via the Over The Air transport services of the Mobile Network Operator MNO. The Service Provider SP communicates with the Trusted Service Manager TSM via a computer network, such as the Internet, wherein the preferred data transmission protocol is HTTPS.

[0024] Additionally or alternatively, the Service Provider SP communicates with the mobile communication device MOB via a computer network and wireless services, e.g. NFC reading devices RD.

[0025] The mobile communication device MOB may e.g. be configured as a NFC mobile phone. The mobile communication device MOB comprises a secure memory element SE which is a memory device with enhanced security features, such as for instance a MIFARE device or a smart card like a SmartMX device. The mobile com-

munication device MOB further comprises a service manager SM that is implemented as a computer program and is configured to manage the received applications app1, app2 ... appx, particularly to install them in the secure memory element SE and to delete them, if necessary. The customer CS consumes or uses the stored applications app1, app2 ... appx by positioning the mobile communication device MOB within the range of the reading device RD which reads and processes the applications in an appropriate manner, e.g. when one application is a transport pass by giving the customer CS access to a public transport system and at the same time reducing the number of remaining public transport tickets by one. In the end, making use of the applications app1, app2 ... appx results in consumed or expired applications that should be deleted from the secure memory element SE in order to free memory space for other applications.

[0026] For the following explanations, let us assume that the application app2 has expired and shall be deleted from the secure memory element SE as shown in the schematic block diagram of Fig. 2. At the time when the application app2 has to be deleted the consumer CS chooses to keep the application app2. Alternatively he could also choose to keep a representation thereof. The consumer CS inputs a collecting request CL into his mobile communication device MOB, e.g. by pressing a combination of keys. The service manager SM in the mobile communication device MOB receives the collecting request CL and handles it by reading the application app2 from the secure memory element SE and storing a copy thereof in a collector memory MM separate from the secure memory element SE. The collector memory MM is either a dedicated memory element such as a memory card inserted into the mobile communication device MOB or an internal memory of the mobile communication device. When copying of the application app2 to the collector memory MM has successfully been completed the service manager SM deletes the expired or consumed application app2 from the secure memory element SE. In other words, the service manager SM handles the customer's CM collecting request CL by moving the application app2 from the secure memory element SE to the collector memory MM. The final state of this operation is shown in Fig. 3. It should be noted that deleting the application app2 from the secure memory element SE can be carried out by the service manager either automatically or upon a specific deleting request of the customer CS.

[0027] With reference to Fig. 3 a second embodiment of the invention will be explained now. Again, it is assumed that the application app2 has expired and shall be deleted from the secure memory element SE. The consumer CS chooses to keep a representation of the application app2. He inputs a collecting request CL into his mobile communication device MOB, e.g. by pressing a combination of keys. The service manager SM in the mobile communication device MOB receives the collecting request CL and handles it by connecting to the Serv-

ice Provider SP, for instance via a wireless Internet connection, and sending a retrieval request RTR to the Service Provider SP asking the Service Provider SP to retrieve the application app2 from its application data base DB and to make it available for the customer CS in a format that has been chosen by the customer CS when inputting the collecting request CL. The chosen format can for instance be selected from the application app2 itself provided in a binary format, an electronic document containing specific information of the application app2 like the price, the name, a release number, a receipt, a characteristic image and so on, or a human-readable format, e.g. by printing it on a printable substrate like a sheet of paper. After the Service Provider SP has formatted the representation RP of the application app2 as requested it transmits it to the customer CS via any suitable communication channel, e.g. via e-mail, or download from a remote server, or mail transport, etc.

[0028] After the service manager SE has sent the retrieval request RTR to the Service Provider SP it will delete the expired or consumed application app2 from the secure memory element SE. Deleting the application app2 from the secure memory element SE can be carried out by the service manager SM either automatically or upon a specific deleting request of the customer CS.

[0029] It should be noted that the above-mentioned embodiments illustrate rather than limit the invention, and that those skilled in the art will be able to design many alternative embodiments without departing from the scope of the appended claims. In the claims, any reference signs placed between parentheses shall not be construed as limiting the claim. The word "comprising" does not exclude the presence of elements or steps other than those listed in a claim. The indefinite article "a" or "an" preceding an element does not exclude the presence of a plurality of such elements. In the device claim enumerating several means, several of these means may be embodied by one and the same item of hardware. The mere fact that certain measures are recited in mutually different dependent claims does not indicate that a combination of these measures cannot be used to advantage.

Claims

1. A method for managing expired or consumed applications (app1, app2 ... appx) that have been provided by a Service Provider (SP) and are stored in a secure memory element (SE) of a mobile communication device (MOB), wherein the method comprises storing a representation (RP) of expired or consumed applications (app1, app2 ... appx) in or on a storage medium that is separate from the secure memory element (SE) and is a memory element (MM) of the mobile communication device (MOB), deleting the expired or consumed application from the secure memory element (SE) of the mobile communication device (MOB),

wherein the mobile communication device (MOB) sends a retrieval request (RTR) to the Service Provider (SP) asking the Service Provider (SP) to format a representation (RP) of the expired or consumed application (app1, app2 ... appx) in a format that has been chosen by the customer (CS), wherein the Service Provider (SP) when receiving the retrieval request (RTR) formats the representation (RP) according to the retrieval request (RTR) and transmits the formatted representation (RP) of the expired or consumed application (app1, app2 ... appx) to the customer (CS) via a communication channel, such as e-mail, or download from a remote server, or mail transport.

2. The method as claimed in claim 1, wherein the representation (RP) of the expired or consumed application is stored in an electronic document that is made available to a customer (CS) of the mobile communication device (MOB).
3. The method as claimed in claim 1, wherein the representation (RP) of the expired or consumed application is stored in a human-readable format by printing it on a printable substrate and making the printed substrate available to a customer (CS) of the mobile communication device (MOB).
4. The method as claimed in claim 1, wherein the representation (RP) of the expired or consumed application is selected from the application itself, or a graphic or written element.
5. A computer program product being directly loadable into a mobile communication device (MOB) with an arithmetic-logic unit and a memory, wherein the computer program product comprises software code portions for performing - when running on the mobile communication device (MOB) - the steps of the method according to any of claims 1 to 4.
6. A computer program product as claimed in claim 5, wherein the computer program product is stored on a computer readable medium or downloadable from a server via a data network.
7. A mobile communication device (MOB) with an arithmetic-logic unit and a memory, being adapted to perform the method steps according to any of claims 1 to 4.

Patentansprüche

1. Ein Verfahren zum Verwalten von abgelaufenen oder verbrauchten Anwendungen (app1, app2 ... appx), welche mittels eines Service Providers (SP) bereitgestellt wurden und in einem sicheren Speicher-

element (SE) einer mobilen Kommunikationsvorrichtung (MOB) gespeichert sind, wobei das Verfahren aufweist Speichern einer Darstellung (RP) von abgelaufenen oder verbrauchten Anwendungen (app1, app2 ... appx), in oder auf einem Speichermedium, das von dem sicheren Speicherelement (SE) getrennt ist und ein Speicherelement (MM) der mobilen Kommunikationsvorrichtung (MOB) ist, Löschen der abgelaufenen oder verbrauchten Anwendung von dem sicheren Speicherelement (SE) der mobilen Kommunikationsvorrichtung (MOB), wobei die mobile Kommunikationsvorrichtung (MOB) eine Retrieval Anfrage zu dem Service Provider (SP) sendet, welche den Service Provider (SP) aufruft, eine Darstellung (RP) der abgelaufenen oder verbrauchten Anwendung (app1, app2 ... appx) in ein Format zu formatieren, welches von dem Verbraucher (CS) ausgewählt wurde, wobei der Service Provider (SP), wenn er die Retrieval Anfrage (RTR) erhält, die Darstellung (RP) gemäß der Retrieval Anfrage formatiert und die formatierte Darstellung (RP) der abgelaufenen oder verbrauchten Anwendung (app1, app2 ... appx) via einen Kommunikationskanal, beispielsweise einer E-Mail oder einem Download von einem entfernten Server oder einer Postbeförderung, zu dem Verbraucher (CS) überträgt.

2. Das Verfahren gemäß Anspruch 1, wobei die Darstellung (RP) der abgelaufenen oder verbrauchten Anwendung in einem elektronischen Dokument gespeichert ist, das einem Verbraucher (CS) der mobilen Kommunikationsvorrichtung (MOB) zugänglich gemacht ist.
3. Das Verfahren gemäß Anspruch 1, wobei die Darstellung (RP) der abgelaufenen oder verbrauchten Anwendung in einem Menschen-lesbaren Format gespeichert ist, indem Sie auf einem bedruckbaren Substrat gedruckt wird und das bedruckte Substrat einem Verbraucher (CS) der mobilen Kommunikationsvorrichtung (MOB) zugänglich gemacht wird.
4. Das Verfahren gemäß Anspruch 1, wobei die Darstellung (RP) der abgelaufenen oder verbrauchten Anwendung ausgewählt ist aus der Anwendung selbst oder einer Graphik oder einem geschriebenen Element.
5. Ein Computerprogramm Produkt, welches in eine mobile Kommunikationsvorrichtung (MOB) mit einer arithmetisch-logischen Einheit und einem Speicher direkt ladbar ist, wobei das Computerprogramm Produkt Softwarecode Teile zum Ausführen der Schritte des Verfahrens gemäß irgendeinem der Ansprüche 1 bis 4 aufweist, wenn es auf der mobilen Kommunikationsvorrichtung (MOB) läuft.

6. Ein Computerprogramm Produkt gemäß Anspruch 5, wobei das Computerprogramm Produkt auf einem Computer lesbaren Medium gespeichert ist oder von einem Server via ein Datennetzwerk herunterladbar ist. 5
7. Eine mobile Kommunikationsvorrichtung (MOB) mit einer arithmetisch-logischen Einheit und einem Speicher, welche eingerichtet ist zum Ausführen der Verfahrensschritte gemäß irgendeinem der Ansprüche 1 bis 4. 10

Revendications

1. Procédé pour gérer des applications expirées ou consommées (app1, app2 ... appx) qui ont été fournies par un fournisseur de services (SP) et sont stockées dans un élément de mémoire sécurisé (SE) d'un dispositif de communication mobile (MOB), dans lequel le procédé comprend de : 15 20

stocker une représentation (RP) d'applications expirées ou consommées (app1, app2 ... appx) dans ou sur un support de stockage qui est distinct de l'élément de mémoire sécurisé (SE) et est un élément de mémoire (MM) du dispositif de communication mobile (MOB), 25

supprimer l'application expirée ou consommée de l'élément de mémoire sécurisé (SE) du dispositif de communication mobile (MOB), 30

dans lequel le dispositif de communication mobile (MOB) envoie une demande de récupération (RTR) au fournisseur de services (SP) demandant au fournisseur de services (SP) de formater une représentation (RP) de l'application expirée ou consommée (app1, app2 ... appx) dans un format choisi par le client (CS), 35

dans lequel le fournisseur de services (SP), lorsqu'il reçoit la demande de récupération (RTR), formate la représentation (RP) en fonction de la demande de récupération (RTR) et transmet la représentation formatée (RP) de l'application expirée ou consommée (app1, app2 ... appx) au client (CS) par l'intermédiaire d'un canal de communication, tel qu'un courrier électronique, ou un téléchargement à partir d'un serveur distant, ou un transport postal. 40 45

2. Procédé selon la revendication 1, dans lequel la représentation (RP) de l'application expirée ou consommée est stockée dans un document électronique qui est mis à la disposition d'un client (CS) du dispositif de communication mobile (MOB). 50 55
3. Procédé selon la revendication 1, dans lequel la représentation (RP) de l'application expirée ou consommée est stockée dans un format lisible par l'homme

en l'imprimant sur un substrat imprimable et en mettant le substrat imprimé à la disposition d'un client (CS) du dispositif de communication mobile (MOB).

4. Procédé selon la revendication 1, dans lequel la représentation (RP) de l'application expirée ou consommée est sélectionnée à partir de l'application elle-même, ou d'un élément graphique ou écrit.
5. Produit de programme informatique pouvant être chargé directement dans un dispositif de communication mobile (MOB) avec une unité arithmétique logique et une mémoire, dans lequel le produit de programme informatique comprend des parties de code logiciel pour effectuer - lorsqu'il est exécuté sur le dispositif de communication mobile (MOB) - les étapes du procédé selon l'une quelconque des revendications 1 à 4.
6. Produit de programme informatique selon la revendication 5, dans lequel le produit de programme informatique est stocké sur un support lisible par ordinateur ou téléchargeable depuis un serveur par l'intermédiaire d'un réseau de données.
7. Dispositif de communication mobile (MOB) avec une unité arithmétique logique et une mémoire, étant conçu pour exécuter les étapes de procédé selon l'une quelconque des revendications 1 à 4.

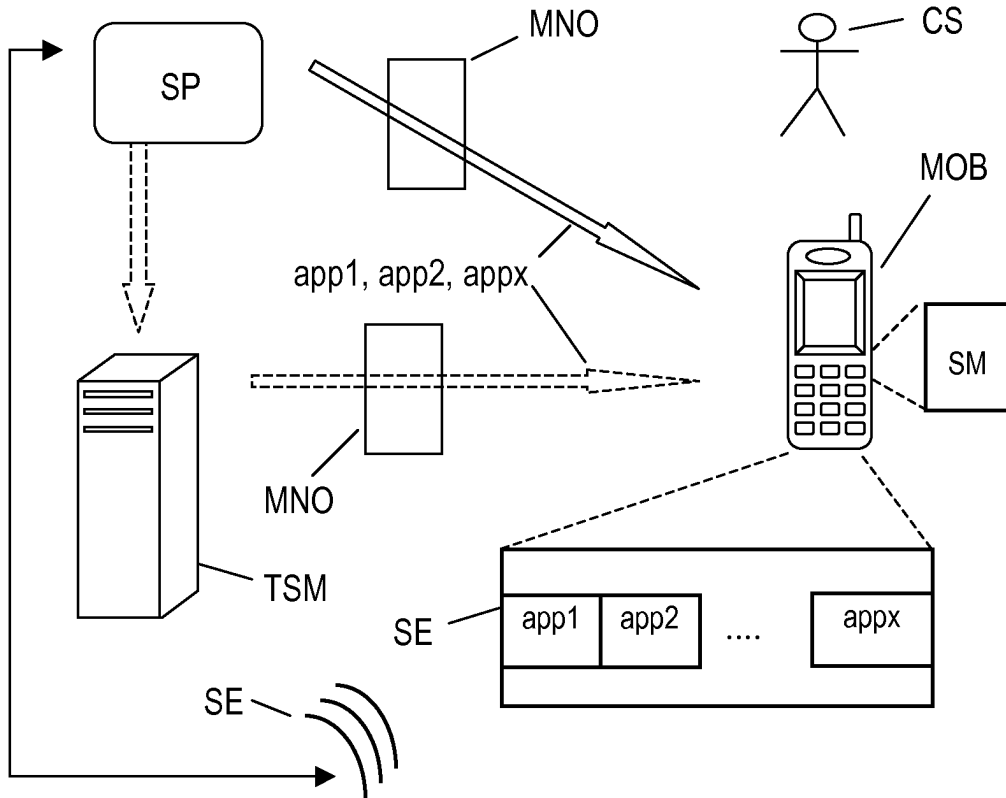

Fig. 1

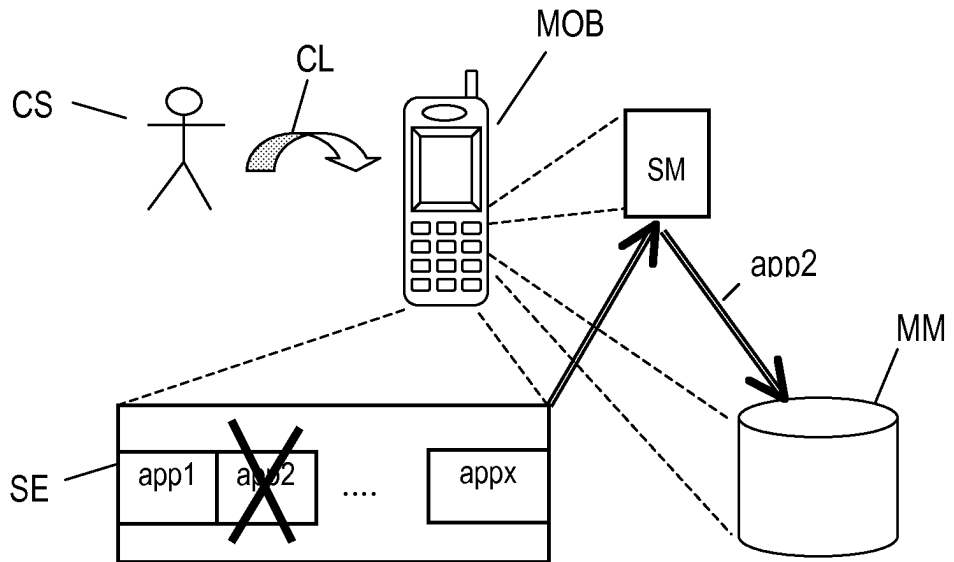

Fig. 2

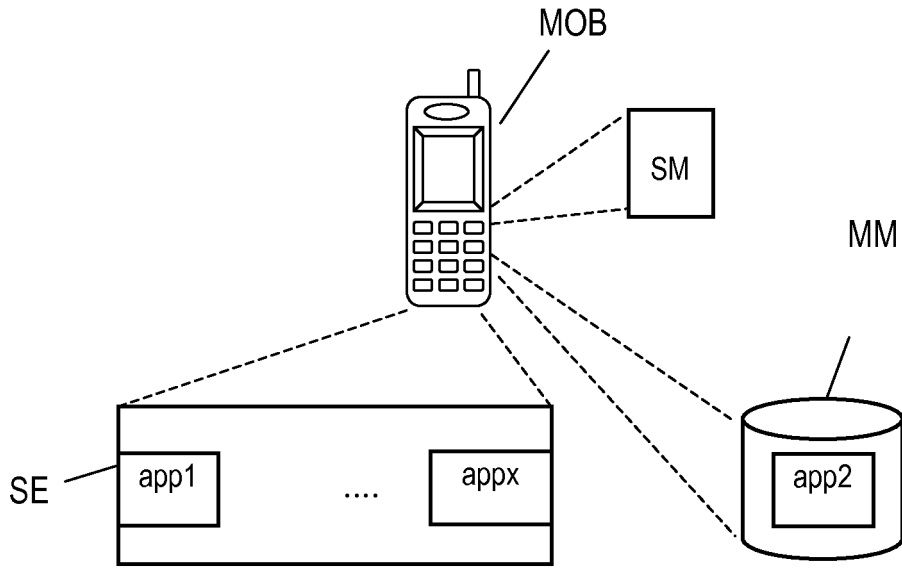

Fig. 3

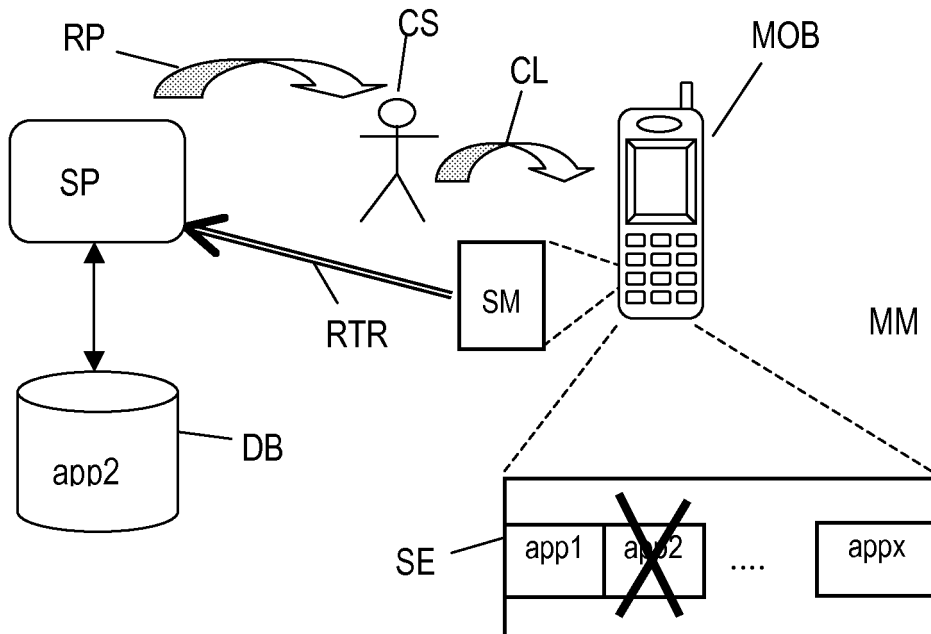

Fig. 4

REFERENCES CITED IN THE DESCRIPTION

This list of references cited by the applicant is for the reader's convenience only. It does not form part of the European patent document. Even though great care has been taken in compiling the references, errors or omissions cannot be excluded and the EPO disclaims all liability in this regard.

Patent documents cited in the description

- WO 2007068991 A1 [0011]
- US 20040235450 A [0012]