



12

EUROPEAN PATENT APPLICATION

21 Application number: 83306944.6

71 Int. Cl.³: B 05 B 9/06, E 01 C 23/16

22 Date of filing: 14.11.83

30 Priority: 15.11.82 US 441864

71 Applicant: **REDLAND PRISMO CORPORATION,**
300 Lanidex Plaza, Parsippany New Jersey 08045 (US)

43 Date of publication of application: 23.05.84
Bulletin 84/21

72 Inventor: **Mark, Gary L., 390 Harding Avenue,**
Williamsport Pennsylvania 17701 (US)
Inventor: **Wands, Kenneth, 306 Gearhart Street,**
Riverside Pennsylvania, 17868 (US)

84 Designated Contracting States: CH DE FR GB LI

88 Date of deferred publication of search
report: 07.11.84 Bulletin 84/45

74 Representative: **Laight, Martin Harvey et al, W H Beck,**
Greener & Company 7 Stone Buildings Lincoln's Inn,
London WC2A 3SZ (GB)

54 Apparatus for and method of controlling rate of deposition of material from a moving vehicle.

57 Apparatus for and method of spraying a substance such as paint onto a road surface or the like to form a coating of uniform thickness in which the speed of the vehicle (10) mounting the system is detected and a speed signal produced which controls air flow through a variable flow air valve (34) to a diaphragm air pump (50) which supplies paint or other substance to a spray gun (22, 24). The speed is detected by a road wheel (40) which feeds a train of pulses to a frequency to D.C. converter (39). The converter (39) produces an electrical signal which controls a transducer (44) for controlling the variable air valve (34).

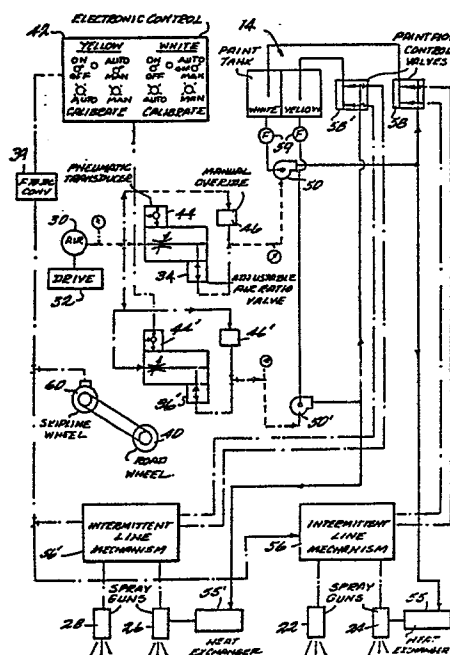



DOCUMENTS CONSIDERED TO BE RELEVANT			
Category	Citation of document with indication, where appropriate, of relevant passages	Relevant to claim	CLASSIFICATION OF THE APPLICATION (Int. Cl. ³)
D, A	US-A-4 247 045 (MITCHELL) * Whole document *	1, 3, 6 8, 10	B 05 B 9/06 E 01 C 23/16
A	--- GB-A- 792 060 (AEROSTYLE LTD.) * Whole document *	1, 9	
A	--- GB-A- 946 541 (THE SANDALL PRECISION CO., LTD.) * Page 4, lines 75-114; page 8, line 33 - page 9, line 95; fig- ures 1-7 *	1	

The present search report has been drawn up for all claims			TECHNICAL FIELDS SEARCHED (Int. Cl. ³)
			E 01 C B 05 B
Place of search THE HAGUE	Date of completion of the search 07-08-1984	Examiner DIJKSTRA G.	
CATEGORY OF CITED DOCUMENTS		T : theory or principle underlying the invention E : earlier patent document, but published on, or after the filing date D : document cited in the application L : document cited for other reasons	
X : particularly relevant if taken alone Y : particularly relevant if combined with another document of the same category A : technological background O : non-written disclosure P : intermediate document		& : member of the same patent family, corresponding document	

