

(21) Application No: **1918612.1**
(22) Date of Filing: **22.05.2018**
Date Lodged: **17.12.2019**
(30) Priority Data:
(31) **62509550** (32) **22.05.2017** (33) **US**
(86) International Application Data:
PCT/GB2018/051383 En 22.05.2018
(87) International Publication Data:
WO2018/215754 En 29.11.2018

(51) INT CL:
H02M 1/44 (2007.01) **H02M 3/156** (2006.01)
(56) Documents Cited:
US 6127816 A **US 20150229211 A1**
US 20140354257 A1 **US 20140035654 A1**
(58) Field of Search:
INT CL **H02M**
Other: **EPO-Internal, WPI Data**

(71) Applicant(s):
Cirrus Logic International Semiconductor Limited
7B Nightingale Way, Quartermile, Edinburgh,
EH3 9EG, United Kingdom
(72) Inventor(s):
Ullas Pazhayaveetil
Sarang Vadnerkar
Theodore Burk
Jeffrey May
(74) Agent and/or Address for Service:
Haseltine Lake Kempner LLP
Redcliff Quay, 120 Redcliff Street, Bristol, BS1 6HU,
United Kingdom

(54) Title of the Invention: **A DC-DC converter**
Abstract Title: **A DC-DC converter**

(57) A DC-DC converter and a corresponding method for maintaining an output voltage of the DC-DC converter, wherein the DC-DC converter is configured to operate in a discontinuous conduction mode, within a predetermined voltage range. The method comprises adjusting a duty cycle of the DC-DC converter based on the output voltage to maintain the output voltage within a predetermined voltage range; wherein the duty cycle of the DC-DC converter is adjusted by switching between a first switching frequency to a second switching frequency, and the first switching frequency and the second switching frequency are selected such that the first switching frequency and the second switching frequency fall outside of at least one predefined disallowed frequency band.

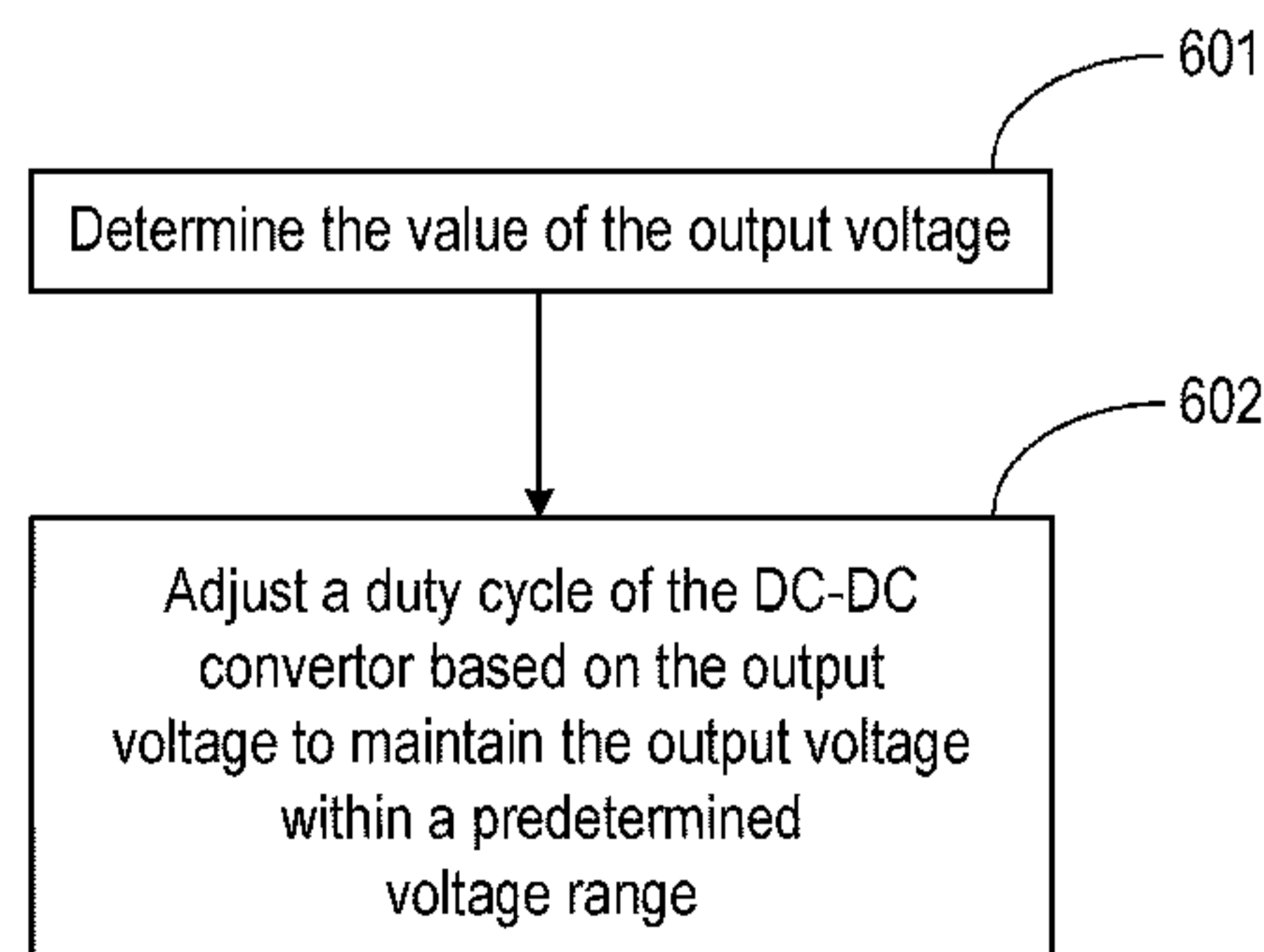

FIG. 6