



## INTERNATIONAL APPLICATION PUBLISHED UNDER THE PATENT COOPERATION TREATY (PCT)

<p>(51) International Patent Classification<sup>6</sup> : <b>A61M 15/00</b></p>	<p><b>A1</b></p>	<p>(11) International Publication Number: <b>WO 96/19253</b></p> <p>(43) International Publication Date: 27 June 1996 (27.06.96)</p>
<p>(21) International Application Number: PCT/SE95/01539</p> <p>(22) International Filing Date: 19 December 1995 (19.12.95)</p> <p>(30) Priority Data: 9404439-3                      21 December 1994 (21.12.94)      SE</p> <p>(71) Applicant (for all designated States except US): ASTRA AKTIEBOLAG [SE/SE]; S-151 85 Södertälje (SE).</p> <p>(72) Inventor; and (75) Inventor/Applicant (for US only): WETTERLIN, Kjell [SE/SE]; Västervång 19, S-247 34 Södra Sandby (SE).</p> <p>(74) Agent: ASTRA AKTIEBOLAG; Patent Dept., S-151 85 Södertälje (SE).</p>		<p>(81) Designated States: AL, AM, AT, AU, BB, BG, BR, BY, CA, CH, CN, CZ, DE, DK, EE, ES, FI, GB, GE, HU, IS, JP, KE, KG, KP, KR, KZ, LK, LR, LS, LT, LU, LV, MD, MG, MK, MN, MW, MX, NO, NZ, PL, PT, RO, RU, SD, SE, SG, SI, SK, TJ, TM, TT, UA, UG, US, UZ, VN, European patent (AT, BE, CH, DE, DK, ES, FR, GB, GR, IE, IT, LU, MC, NL, PT, SE), OAPI patent (BF, BJ, CF, CG, CI, CM, GA, GN, ML, MR, NE, SN, TD, TG), ARIPO patent (KE, LS, MW, SD, SZ, UG).</p> <p><b>Published</b> <i>With international search report. Before the expiration of the time limit for amending the claims and to be republished in the event of the receipt of amendments.</i></p>

(54) Title: AN INHALATION DEVICE, A METHOD OF DISPERSING A PHARMACEUTICALLY ACTIVE SUBSTANCE AND A METHOD OF ADMINISTERING A DOSE OF A PHARMACEUTICALLY ACTIVE SUBSTANCE

## (57) Abstract

An inhalation device for inhalation of a pharmaceutically active substance from a reservoir in an inhaler (12) comprising an inhalation channel with an air inlet and an air outlet, said device comprising a dispersing chamber (20) having an air inlet and an air outlet into which the active substance may be sucked from said reservoir through the air outlet and means for allowing a user to inhale the active substance from said dispersing chamber, said dispersing chamber being defined by at least a first non-movable element (10) and a second movable element (6), said second element being substantially cylindrical, said first element being arranged in said second element whereby a vacuum or negative pressure is created in said dispersing chamber when said first and second elements are moved in relation to each other, wherein said first non-movable element is fixed on the inhaler so that the second element will move in relation to both the first element and the inhaler when the device is activated for inhalation. The invention also relates to a method of dispersing a pharmaceutically active substance in a dispersing chamber by creating a negative pressure or vacuum in said dispersing chamber. The invention also relates to a method of administering a dose of a pharmaceutically active substance through the mouth piece (22).

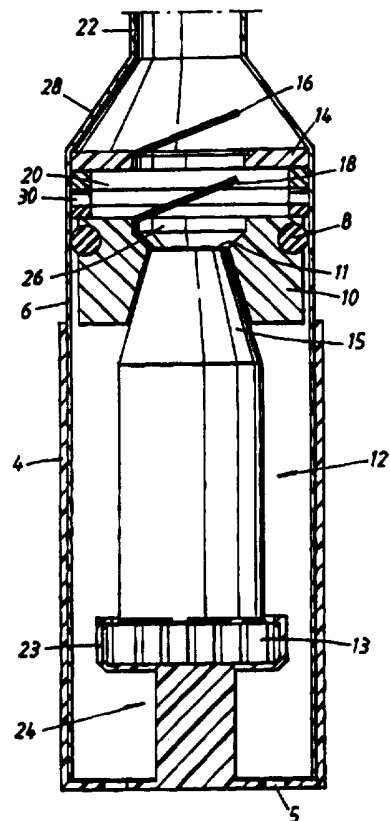

**FOR THE PURPOSES OF INFORMATION ONLY**

Codes used to identify States party to the PCT on the front pages of pamphlets publishing international applications under the PCT.

<b>AT</b>	Austria	<b>GB</b>	United Kingdom	<b>MR</b>	Mauritania
<b>AU</b>	Australia	<b>GE</b>	Georgia	<b>MW</b>	Malawi
<b>BB</b>	Barbados	<b>GN</b>	Guinea	<b>NE</b>	Niger
<b>BE</b>	Belgium	<b>GR</b>	Greece	<b>NL</b>	Netherlands
<b>BF</b>	Burkina Faso	<b>HU</b>	Hungary	<b>NO</b>	Norway
<b>BG</b>	Bulgaria	<b>IE</b>	Ireland	<b>NZ</b>	New Zealand
<b>BJ</b>	Benin	<b>IT</b>	Italy	<b>PL</b>	Poland
<b>BR</b>	Brazil	<b>JP</b>	Japan	<b>PT</b>	Portugal
<b>BY</b>	Belarus	<b>KE</b>	Kenya	<b>RO</b>	Romania
<b>CA</b>	Canada	<b>KG</b>	Kyrgystan	<b>RU</b>	Russian Federation
<b>CF</b>	Central African Republic	<b>KP</b>	Democratic People's Republic of Korea	<b>SD</b>	Sudan
<b>CG</b>	Congo	<b>KR</b>	Republic of Korea	<b>SE</b>	Sweden
<b>CH</b>	Switzerland	<b>KZ</b>	Kazakhstan	<b>SI</b>	Slovenia
<b>CI</b>	Côte d'Ivoire	<b>LI</b>	Liechtenstein	<b>SK</b>	Slovakia
<b>CM</b>	Cameroon	<b>LK</b>	Sri Lanka	<b>SN</b>	Senegal
<b>CN</b>	China	<b>LU</b>	Luxembourg	<b>TD</b>	Chad
<b>CS</b>	Czechoslovakia	<b>LV</b>	Larvia	<b>TG</b>	Togo
<b>CZ</b>	Czech Republic	<b>MC</b>	Monaco	<b>TJ</b>	Tajikistan
<b>DE</b>	Germany	<b>MD</b>	Republic of Moldova	<b>TT</b>	Trinidad and Tobago
<b>DK</b>	Denmark	<b>MG</b>	Madagascar	<b>UA</b>	Ukraine
<b>ES</b>	Spain	<b>ML</b>	Mali	<b>US</b>	United States of America
<b>FI</b>	Finland	<b>MN</b>	Mongolia	<b>UZ</b>	Uzbekistan
<b>FR</b>	France			<b>VN</b>	Viet Nam
<b>GA</b>	Gabon				

An inhalation device, a method of dispersing a pharmaceutically active substance and a method of administering a dose of a pharmaceutically active substance.

The present invention relates to an inhalation device for inhalation of a pharmaceutically active substance from a reservoir in an inhaler comprising an inhalation channel with an air inlet and an air outlet, said device comprising a dispersing chamber having an air inlet and an air outlet into which the active substance may be sucked from said reservoir through the air outlet and means for allowing a user to inhale the active substance from said dispersing chamber, said dispersing chamber being defined by at least a first non-movable element and a second movable element, said second element being substantially cylinder-formed, said first element being arranged in said second element whereby a vacuum or negative pressure is created in said dispersing chamber when said first and second elements are moved in relation to each other, as described in the preamble of claim 1.

The inhalation device according to the invention is preferably a breath-actuated dry-powder inhaler, containing multiple doses of a medicament containing an active substance, the inhaler having manoeuvring unit comprising a manoeuvring unit for loading one dose of the medicament to a dosing unit and providing said dose in a position for inhalation. An inhaler of the prescribed type is described in EP-A-0 069 715 and EP-A-0 237 507.

The device according to the invention is especially designed for patients who are not able to actively inhale or who are not able to create the inhalation flow necessary to release and lift the dose of the substance into the inhalation channel and to the lungs when using a breath-actuated inhaler.

### **Background of invention**

Inhalable pharmaceutically active substances are generally used for treatment of diseases in the bronchial and pulmonary area, such as asthma and chronic bronchitis. Various embodiments of inhalation devices or apparatus are used for the purpose. The function of these known devices is depending on the creation of an airflow through the inhalation device caused by an inhalation by the patient. The airflow causes active substance to

moved from a release position into the airflow in which it is dispersed. A specially advantageous inhaler of the above mentioned type is the dry-powder, breath-actuated multidose inhaler Turbuhaler®, schematically described in the above mentioned EP-patents.

5

Some patients such as small children and elderly people with diseases in the bronchial area are not able to use a breath-actuated inhaler as it might be hard or even impossible for these patients to achieve the necessary inhalation flow and these patients are today reduced to the use of inhalers using pressurised gas, i.e. freon. Such inhalers suffer from many known disadvantages, such as unwanted side effects.

10

Furthermore, it is presently a problem to administer an Inhalable substance to an asthma patient who is anaesthetised during an operation and the patient can not actively inhale. For many asthmatic patients the administration of asthma pharmaceuticals during an operation is vital.

15

### **Prior art**

In order to facilitate the inhalation of pharmaceutically active substances being administered by the use of pressurised metered dose inhalers, so called pMDI:s, it is known to provide expansion chambers into which the substance, with the pressurised gas, is dispersed. These devices are generally called spacers and a typical spacer is known from GB 1 565 029.

20

Furthermore, inhalation devices including dispersion chambers have been developed for breath-actuated dry-powder inhalers of the above mentioned type. Such an inhalation device is described in EP-A-0 548 152. This device is however bulky and contains several mechanical parts which makes the device complicated and expensive to produce and to use. The reliability is not very high due to the complexity of the device.

25

The present invention relates to an inhalation device of the above mentioned type which can be used by patients having reduced ability to create an inhalation flow necessary to lift the dose from the release position into the inhalation channel when using a breath-actuated inhaler, and which can be used to administer Inhalable substances to a patient being  
5 anaesthetised.

The invention provides a device which facilitates the use of especially a Turbuhaler® for patients presently being reduced to the use of pressurised metered-dose inhalers.

10 The inhalation device according to the invention has a non-complicated construction with few mechanical parts, is simple and cheap to produce and is easy to use by the patient.

In the device according to the invention a first non-movable element is fixed on the inhaler so that a second element will move in relation to both the first element and the inhaler  
15 when the device is activated for inhalation, as described in the characterising part of claim 1.

Further advantages with the present invention are clear from the depending claims 2 to 16.

20 The present invention also includes a method of dispersing a pharmaceutically active substance, in a dispersing chamber by creating a negative pressure or vacuum in said dispersing by using a device as according to the invention. The dispersed substance could thereby be inhaled using an ordinary inhalation flow or it could be pressed out from the inhalation device, as described in claims 17 to 19.

25

#### **Brief description of the drawing**

The inhalation device according to the present invention will now be described by way of example with reference to the appended drawings, in which

30 Fig. 1 shows a schematic view of a section of the inhalation device according to a first

embodiment of the invention; and

Fig. 2 shows a schematic view of a section of the second embodiment of the inhalation device according to the invention.

5 **Detailed description of the drawing**

The device according to the invention is intended to be used in connection with an inhaler for inhalation of a pharmaceutically active substance, e.g. the breath-actuated, dry-powder, multidose inhaler 12 sold under the trademark Turbuhaler®. The inhalation device according to the invention may be modified within the scope of the appended claims to be used with any dry-powder inhaler which when activated positions a dose of the medicament in a release position in the inhalation channel.

The preferred inhaler 12 is provided with a reservoir for storing the substance, a metering or dosing unit, an air flow path having an air inlet and an air outlet. The inhaler is also provided with operating means comprising a manoeuvring unit 13 for moving a metering device from a loading position in which a predetermined dose of the substance to be inhaled is metered into the metering device and a release position where the dose is placed in the inhalation channel, released and carried by the inhalation air through the channel to the air outlet or mouthpiece 15 of the inhaler.

20 As can be seen in the drawings the inhalation device according to the invention comprises a first substantially non-moving element 10 which is provided on the air outlet or mouth piece 15 of the inhaler. The first element 10 is formed as a piston having an opening 26 which, when the piston is arranged on the air outlet of the inhaler, coincides with the opening 11 of the air outlet. The connection between the air outlet or mouth piece 15 of the inhaler and the piston is air tight through a sealing or as in the preferred embodiment the piston is rigidly mounted on the outer walls of the air outlet or mouth piece 15 of the inhaler in order to prevent air from entering between the two parts. The piston could be glued, welded or rigidly fastened in any other manner to the inhaler.

Around said first substantially non-moving element, i.e. the piston 10, a movable second element 6 is provided. Said second element 6 is hollow and substantially formed as a cylinder. In the upper part of the cylinder the walls merge and define a cone-shaped part 28. Above this cone-shaped part 28 a further cylinder 22 having a smaller diameter than the cylinder 6 defining the second element is arranged. Said cylinder 22 defines the air outlet of the dispersing chamber 20 and the inhalation device and is formed as a mouth piece or nose adapter part.

The piston 10 is arranged inside the cylinder 6. The piston thereby defines the bottom of the second element 6. A dispersing chamber 20 is defined in the cylinder 6 above the piston 10. Sealing means 8 are provided between the first and second elements at their mutual area of connection. The sealing means 8 are preferably provided as an O-ring sealing member and could be arranged in a groove provided on the outer surface of the piston.

As mentioned above the piston is formed with an opening 26 which coincides with the opening 11 of the air outlet or mouth piece 15 of the inhaler. First valve means 18 are provided regulating the air flow through the air outlet and the opening in the piston to the dispersing chamber. The valve means are provided as a one way valve arranged to only open when the air flows from the inhaler to the dispersing chamber. The valve could be of any known type and is in the preferred embodiment formed as a thin membrane of which one part is fixed to the wall of the piston and the other end is free moving.

The cylinder 6 is formed with a limiting wall member 14 having an outlet opening coinciding with the air outlet of the inhaler. The wall member 14 defines the upper restriction of the dispersing chamber 20 and is provided with holding means 30 for holding the inhaler in a fixed position in relation to the rotation when the manoeuvring unit 13 are rotated. These means could be provided as a ratchet mechanism, as teeth rings or have any other construction. Second valve means 16 are provided in said opening for regulating the air flow out from the dispersing chamber upon inhalation of a user. A mouth piece 22 or

nose adapter is provided at the end of the cylinder 6.

The first and second valves 18 and 16 are preferably of similar construction and must be sensitive and easy to open in order to minimise the inhalation flow resistance and retention  
5 of substance within the inhalation device. For this purpose the valve could preferably be made as thin membranes of plastic or the like. The membranes could be fixed at one end in the opening of the piston 10 and the wall member 14 respectively, as can be seen in the figure. The wall member 14 acts as a valve seat for the valve 18.

10 In a first preferred embodiment a further hollow cylinder element 4 is provided. The cylinder is defined by a bottom and wall parts and is opened in its upper region. The bottom of said further cylinder is provided with air inlet openings 5 communicating with the inside of said further cylinder element 4. A mounting element 24 for the inhaler is provided inside said further cylinder and fixed to the bottom of the cylinder. The mounting  
15 element 24 comprises a portion 23 adapted to the form of the manoeuvring unit 13 of the inhaler in order for it to be fixedly mounted in said mounting means 24.

Due to this fixed and rigid mounting of the manoeuvring unit 13 of the inhaler 12 in the mounting part 23 the unit 13 is rotated an angle proportional to the rotation of the outer  
20 cylinder-formed element 4. The rotation of the outer cylinder-formed element 4 and thereby the manoeuvring unit 13 activates the inhaler 12 for inhalation as the manoeuvring unit places the dosing unit and thereby a dose in the release position within the inhalation channel.

25 The function of this embodiment will now be described.

In the inactive position, which is shown in fig. 1, the inner cylinder-formed element 6 is totally interposed into the outer cylinder-formed element 4. When the outer element 4 is turned the manoeuvring unit 13 and the dosing unit of the inhaler is turned and a dose is  
30 placed in release position in the inhalation channel. The two cylinder formed element 4 and



6 are thereafter moved axially in relation to each other whereby the inhaler 12 with the piston 10 is pressed downwards along the inner wall of the inner element 6. A low-pressure or vacuum is created in the inner chamber 20 which is created when the elements are moved away from each other. The second valve 16 closes.

5

The valve 18 opens and air is drawn into the inhalation device through the air inlets 5 in the bottom part of the outer element 4. When the air passes the inhaler, the dose placed in the inhalation channel is released and dispersed into the inner chamber 20.

10 The dispersed substance could now be actively inhaled by the patient, a method which could be used also by small children, elderly people and others with reduced inhalation capacity .

Alternatively the substance can be forced out of the inner chamber by pressing the piston  
15 10 and the second element 6 together again after the activation and dispersion of the dose has taken place. The volume in the dispersing chamber will then decrease and an over pressure or positive pressure will be created. The valve 18 will open and air/substance contents of the dispersing chamber will be forced out through the mouth piece 22 of the device. In this manner substance can be forced down into the lungs of the patient. This  
20 active pressing out of the substance is especially intended to be used when treating an anaesthetised patient but could also be used under other circumstances, e.g. by small children or elderly people refusing to inhale.

The inhalation device could also be constructed without the outer cylinder 4.

25

A biasing element 32 is thereby provided between the piston 10, which is mounted on the mouthpiece and/or upper part of the inhaler, and the cylinder 6. The cylinder 6 is provided with stop means 35 provided at the opened end of the cylinder preventing the cylinder from being separated from the piston 10. Further sealing means 36 are provided between the  
30 piston 10 and the cylinder 6. In this embodiment in the inactivated position of the device

the piston 10 is arranged in relation to the cylinder in such an manner that the dispersing chamber has its largest volume, i.e. the piston and the cylinder are in the retracted position in relation to each other. When the device is activated for inhalation a dose is placed in the inhalation channel by the rotating movement of the manoeuvring unit 13, which in this  
5 embodiment is handled directly by the user. The piston 10 is then moved within the cylinder 6, i.e. the piston is pushed towards the outlet of the cylinder 6, against the force of the biasing element 32. The volume of the dispersing chamber is decreased. The piston 10 is then released and will due to the force of the biasing element travel instantly towards the  
10 bottom of the cylinder thereby creating a negative pressure or vacuum in the dispersing chamber as the volume increases. The dose will be sucked with the air entering into the air inlets of the inhaler to the inhalation channel and further up to the dispersing chamber. When the pressure has been compensated the valve 18 will close and the user can inhale through the mouth piece as described above.

15 Further sealing means could be provided in order to secure an airtight sealing between the inhaler 12, the piston 10 and the cylinder 6.

The biasing element is preferably a spiral spring but any other type of resilient element could be used.

20

The use of the device to force the dose to be inhaled down into the lungs of a patient as described above could of course also be used with a device constructed in accordance with the second embodiment of the invention.

25 The volume of the spacer could be varied due to requirements and needs, and a preferred maximum volume of the dispersing chamber is between 50 - 250 ml.

The different parts of the inhalation device are preferably made of plastics, metallized plastics or metal but other materials are also possible.

30

The present invention is preferably directed to the use of a pharmaceutically active substance in powdered form wherein the powder is dispersed into the inner chamber of the inhalation device in a finely divided form wherein the particles are smaller than 10 $\mu$ m, preferably smaller than 3 $\mu$ m.

5

**Possible modifications of the invention**

The inhalation device according to the present invention could of course be modified within the scope of the appended claims.

10 In the preferred embodiment the means for generating the negative pressure or vacuum are two cylinder-formed elements provided telescopically in relation to each other. In the preferred embodiment the elements have a circular cross-section but any other form such as squared is possible.

15 In the second embodiment a further cylinder could be provided in the second element 6. Said further cylinder is arranged to be separately movable in relation to the second element 6, whereby the biasing means are provided in a space between the two cylinders.

**Claims**

1. An inhalation device for inhalation of a pharmaceutically active substance from a reservoir in an inhaler (12) comprising an inhalation channel with an air inlet and an air outlet, said device comprising a dispersing chamber (20) having an air inlet and an air outlet into which the active substance may be sucked from said reservoir through the air outlet and means (16, 22) for allowing a user to inhale the active substance from said dispersing chamber (20), said dispersing chamber (20) being defined by at least a first non-movable element (10) and a second movable element (6), said second element (6) being substantially cylinder-formed, said first element (10) being arranged in said second element (6) whereby a vacuum or negative pressure is created in said dispersing chamber (20) when said first and second elements (10, 6) are moved in relation to each other, characterized in that said first non-movable element (10) is fixed on the inhaler (12) so that the second element (6) will move in relation to both the first element (10) and the inhaler when the device is activated for inhalation.

2. Inhalation device according to claim 1, characterized in that the first non-movable element (10) is fixed on the inhaler on the air outlet (15) adjacent the air outlet (11).

3. Inhalation device according to claim 1 or 2, characterized in that an air tight sealing (8) is provided between the outer surface of the piston (10) and the inner surface of the second element (6).

4. Inhalation device according to claim 1,2 or 3, characterized in that said first element (10) is formed as a piston having an opening (26) and being provided on and surrounding the air outlet of the inhaler (12), whereby an air tight sealing is provided between the piston and the air outlet of the inhaler.

5. Inhalation device according to claim 4,

characterised in that said opening of the piston is provided in direct alignment with the opening of the air outlet of the inhaler (12).

5 6. Inhalation device according to claim 4 or 5,

characterised in that first valve means (18) are provided closing the opening of the piston (10), said valve means (18) being provided to open when negative pressure or vacuum is created in said dispersing chamber (20) and air is sucked through the inhaler to said chamber.

10

7. Inhalation device according to any of the preceding claims,

characterised in that further valve means (16) are provided closing the opening or air outlet (22) of the second element (6), said further valve means (16) being provided to open when a user inhales through said air outlet (22).

15

8. Inhalation device according to claims 6 or 7,

characterised in that said valve means (16, 18) are formed as thin membranes rigidly attached at their one end to the walls of the first and second elements respectively and freely movable at their other end.

20

9. Inhalation device according to any of the preceding claims,

characterised in that inhaler is a conventional dry-powder inhaler.

10. Inhalation device according to claim 9,

25

characterised in that said inhaler comprises manoeuvring means (13), said means comprising a dosing unit and a dosing disc for feeding a dose of the pharmaceutically active powdered substance from a loading position to a position for inhalation in the inhalation channel of the inhaler.

- 11. Inhalation device according claim 10,**  
c h a r a c t e r i s e d in that said inhaler is a breath-actuated dry-powder inhaler, preferably a Turbuhaler®.
- 5 **12. Inhalation device according to any of the preceding claims,**  
c h a r a c t e r i s e d in that the piston (10) is rigidly mounted on the air outlet or mouth piece 15 of the inhaler (12).
- 13. Inhalation device according to any of the preceding claims,**  
10 c h a r a c t e r i s e d in that a further substantially cylinder formed element (4) is provided around the outer surface of the first cylinder formed element (6) and being rotatable relative to said second element (6), said further cylinder formed element (4) having mounting means (24) in its lower part for mounting the inhaler in said element (4).
- 15 **14. Inhalation device according to claim 13,**  
c h a r a c t e r i s e d in that the manoeuvring means (13) of the inhaler are fixedly provided in the mounting means of the further cylinder formed element (4) so that a rotation of the further cylinder formed element (4) in relation to the second element (6) will rotate the manoeuvring means of the inhaler and activate the inhaler for inhalation.
- 20 **15. Inhalation device according to claims 1 to 11,**  
c h a r a c t e r i s e d in that biasing means (32) are provided between the piston (10) and the second element (6).
- 25 **16. Inhalation device according to claims 15,**  
c h a r a c t e r i s e d in that said biasing means (26) are a spiral spring.

**17. Method of dispersing a pharmaceutically active substance in a dispersing chamber (20) by creating a negative pressure or vacuum in said dispersing chamber by using a device as according to claims 1 to 14.**

5 **18. Method of administering a dose of a pharmaceutically active powdered substance by using an inhalation device according to claims 1 to 16 whereby the device is also used to force the dose in the dispersing chamber (20) out through the air outlet/mouth piece (22) of the device.**

10 **19. Method according to claim 18, wherein the piston (10) and the second element (6) are forced to move in a direction opposite to the direction of creating said negative pressure or vacuum in the dispersing chamber whereby a over pressure or positive pressure will be created in the dispersing chamber forcing the dose out of the device.**

**Abstract**

An inhalation device for inhalation of a pharmaceutically active substance from a reservoir in an inhaler comprising an inhalation channel with an air inlet and an air outlet, said  
5 device comprising a dispersing chamber having an air inlet and an air outlet into which the active substance may be sucked from said reservoir through the air outlet and means for allowing a user to inhale the active substance from said dispersing chamber, said dispersing chamber being defined by at least a first non-movable element and a second movable element, said second element being substantially cylinder-formed, said first element being  
10 arranged in said second element whereby a vacuum or negative pressure is created in said dispersing chamber when said first and second elements are moved in relation to each other, wherein said first non-movable element is fixed on the inhaler so that the second element will move in relation to both the first element and the inhaler when the device is activated for inhalation.

15

The invention also relates to a method of dispersing a pharmaceutically active substance in a dispersing chamber by creating a negative pressure or vacuum in said dispersing chamber.

20 **Fig. 1**



Fig. 1

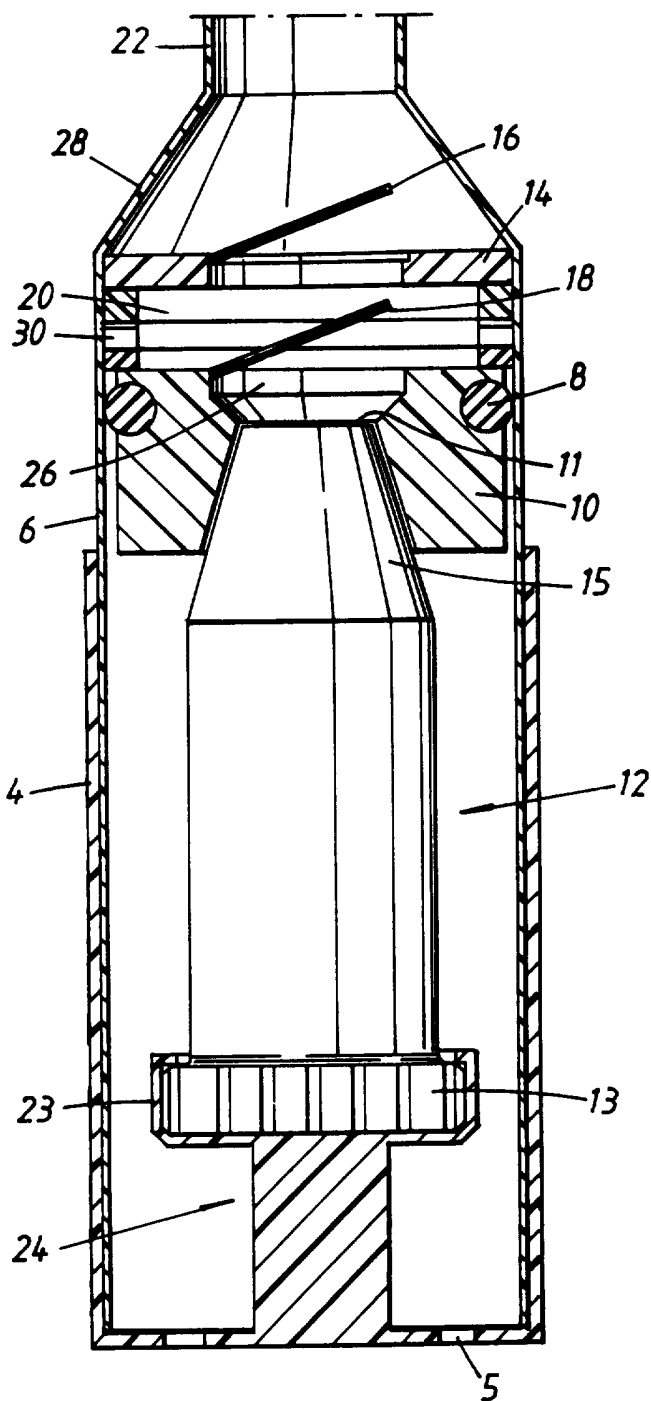
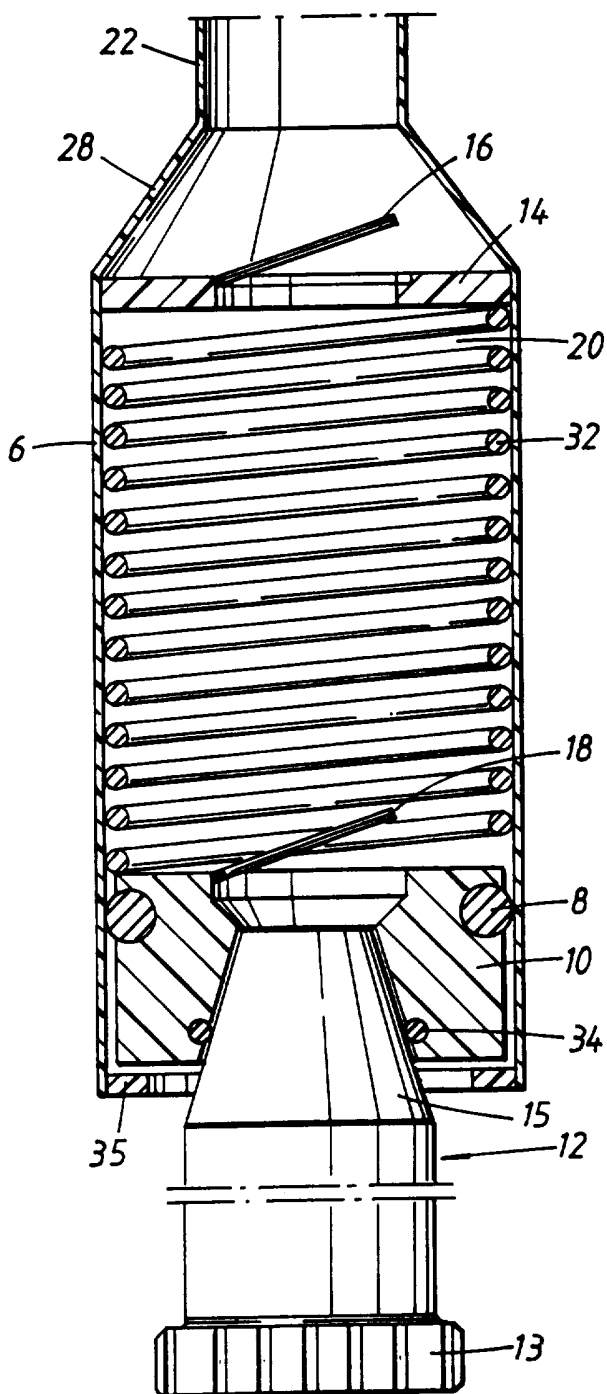

Fig. 2



## INTERNATIONAL SEARCH REPORT

International application No.

PCT/SE 95/01539

## A. CLASSIFICATION OF SUBJECT MATTER

IPC6: A61M 15/00

According to International Patent Classification (IPC) or to both national classification and IPC

## B. FIELDS SEARCHED

Minimum documentation searched (classification system followed by classification symbols)

IPC6: A61M

Documentation searched other than minimum documentation to the extent that such documents are included in the fields searched

SE,DK,FI,NO classes as above

Electronic data base consulted during the international search (name of data base and, where practicable, search terms used)

## C. DOCUMENTS CONSIDERED TO BE RELEVANT

Category*	Citation of document, with indication, where appropriate, of the relevant passages	Relevant to claim No.
A	US 5341801 A (KURT ZEICHNER), 30 August 1994 (30.08.94), see the whole document  -----	1-12

Further documents are listed in the continuation of Box C.

See patent family annex.

## \* Special categories of cited documents:

- "A" document defining the general state of the art which is not considered to be of particular relevance
- "E" earlier document but published on or after the international filing date
- "L" document which may throw doubts on priority claim(s) or which is cited to establish the publication date of another citation or other special reason (as specified)
- "O" document referring to an oral disclosure, use, exhibition or other means
- "P" document published prior to the international filing date but later than the priority date claimed

"T" later document published after the international filing date or priority date and not in conflict with the application but cited to understand the principle or theory underlying the invention

"X" document of particular relevance: the claimed invention cannot be considered novel or cannot be considered to involve an inventive step when the document is taken alone

"Y" document of particular relevance: the claimed invention cannot be considered to involve an inventive step when the document is combined with one or more other such documents, such combination being obvious to a person skilled in the art

"&" document member of the same patent family

Date of the actual completion of the international search

24 May 1996

Date of mailing of the international search report

29 -05- 1996

Name and mailing address of the ISA/  
Swedish Patent Office  
Box 5055, S-102 42 STOCKHOLM  
Facsimile No. +46 8 666 02 86

Authorized officer

Anette Hall  
Telephone No. +46 8 782 25 00

# INTERNATIONAL SEARCH REPORT

Information on patent family members

01/04/96

International application No.

PCT/SE 95/01539

Patent document cited in search report	Publication date	Patent family member(s)	Publication date
US-A- 5341801	30/08/94	AT-T- 136225 CA-A- 2084214 EP-A,A,A 0546996 JP-A- 5237189	15/04/96 04/06/93 16/06/93 17/09/93

---