



US00D582875S

(12) **United States Design Patent**
Haspil et al.

(10) **Patent No.:** **US D582,875 S**

(45) **Date of Patent:** **** Dec. 16, 2008**

(54) **COMMUNICATION TABLET**

(75) Inventors: **John Haspil**, Boerne, TX (US); **Susan S. Steele**, Alpharetta, GA (US); **David Mornhineway**, San Antonio, TX (US); **Jerry O'Leary**, Chicago, IL (US); **Larry B. Pearson**, San Antonio, TX (US); **Tyler Wallis**, San Antonio, TX (US)

(73) Assignee: **AT&T Intellectual Property I, L.P.**, Reno, NV (US)

(**) Term: **14 Years**

(21) Appl. No.: **29/284,419**

(22) Filed: **Sep. 7, 2007**

(51) **LOC (8) Cl.** **14-03**

(52) **U.S. Cl.** **D14/138 G; D14/341**

(58) **Field of Classification Search** D14/137, D14/138, 147, 191, 218, 247-248, 341-347, D14/496; D10/65, 78, 104; D13/168; D18/7; 455/556.1, 566, 575.1, 575.3; 345/169

See application file for complete search history.

(56) **References Cited**

U.S. PATENT DOCUMENTS

D341,823 S *	11/1993	Sakai	D14/341
6,282,082 B1 *	8/2001	Armitage et al.	361/681
D458,252 S *	6/2002	Palm et al.	D14/343
D476,005 S *	6/2003	Peng et al.	D14/375
D481,719 S *	11/2003	Okawa et al.	D14/341
D490,420 S *	5/2004	Solomon et al.	D14/341
D501,007 S *	1/2005	Heng	D14/341
D502,179 S *	2/2005	Cha et al.	D14/375
D505,676 S *	5/2005	Porter et al.	D14/388
D521,524 S *	5/2006	Chang	D14/496
D528,541 S *	9/2006	Maskatia	D14/315
D532,791 S *	11/2006	Kim	D14/496
D548,733 S *	8/2007	Johansson	D14/341
D553,153 S *	10/2007	Kim	D14/496
D556,211 S *	11/2007	Howard	D14/496
D558,460 S *	1/2008	Yu et al.	D6/308

D563,804 S *	3/2008	Kimura et al.	D10/65
D563,806 S *	3/2008	Jeon	D10/65
D563,807 S *	3/2008	Jeon	D10/65
D565,978 S *	4/2008	Stevens et al.	D10/65
2003/0236102 A1 *	12/2003	Kawai et al.	455/550.1
2004/0174137 A1 *	9/2004	Kim et al.	320/114
2005/0227737 A1 *	10/2005	Moon et al.	455/566
2005/0272483 A1 *	12/2005	Ko et al.	455/575.1
2007/0032273 A1 *	2/2007	Hsiao et al.	455/575.1
2008/0069323 A1 *	3/2008	Walter et al.	379/111

FOREIGN PATENT DOCUMENTS

WO DM/068932 * 3/2007

OTHER PUBLICATIONS

Nokia 7710, announced 4th quarter 2004, [online], [retrieved on May 23, 2008]. Retrieved from Internet ,<URL: <http://www.gsmarena.com>>.*

Motorola Sidekick Slide, announced Sep. 2007, [online], [retrieved on May 23, 2008]. Retrieved from Internet ,<URL: <http://www.gsmarena.com>>.*

Samsung F700, announced Feb. 2007, [online], [retrieved on Feb. 8, 2007]. Retrieved from Internet ,<URL: <http://www.gsmarena.com>>.*

* cited by examiner

Primary Examiner—Jeffrey D Asch

Assistant Examiner—Bridget L Eland

(74) *Attorney, Agent, or Firm*—Ed Guntin; Akerman Senterfitt

(57) **CLAIM**

What is claimed is the ornamental design for a communication tablet, as shown and described.

DESCRIPTION

FIG. 1 is a perspective front view of a communication tablet showing a first embodiment of a new design;

FIG. 2 is a front view of the ornamental design of FIG. 1;

FIG. 3 is a rear view of the ornamental design of FIG. 1;

FIG. 4 is a left side view of the ornamental design of FIG. 1;

FIG. 5 is a right side view of the ornamental design of FIG. 1;

FIG. 6 is a top plan view of the ornamental design of FIG. 1;

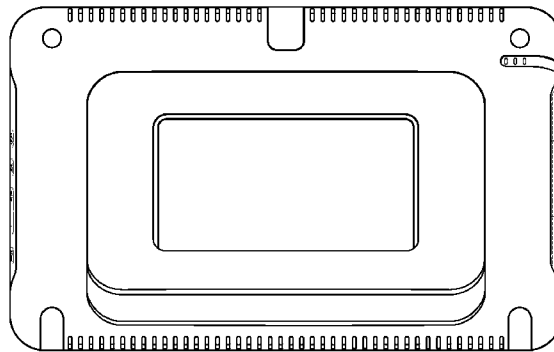
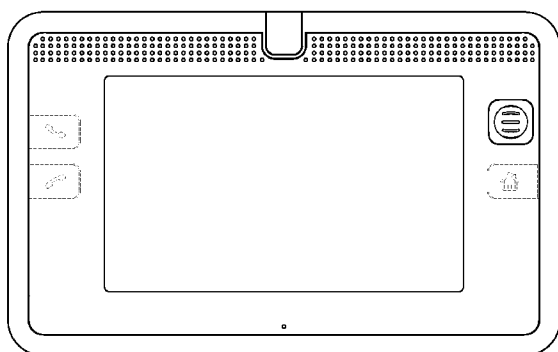

FIG. 7 is a bottom plan view of the ornamental design of FIG. 1;

FIG. 8 is a perspective view of the ornamental design of FIG. 1 in a first position of a stand;

FIG. 9 is a perspective view of the ornamental design of FIG. 1 in a second position of the stand; and

FIG. 10 is a perspective view of a second embodiment of the communication tablet of FIG. 1 with the FIGS. 1–7 views being the same with the exception of the unclaimed stand;

FIG. 11 is an alternative perspective rear view of FIG. 10; and

FIG. 12 is a perspective front view of a third embodiment of the communication tablet of FIG. 1 with the FIGS. 4–5, and 7 views being the same;

FIG. 13 is a front view of the ornamental design of FIG. 12;

FIG. 14 is a rear view of the ornamental design of FIG. 12; and

FIG. 15 is a top plan view of the ornamental design of FIG. 12; and

FIG. 16 is a perspective front view of a fourth embodiment of the communication tablet of FIG. 1 with the FIGS. 4–5, and 7 views being the same with the exception of the unclaimed camera;

FIG. 17 is a front view of the ornamental design of FIG. 16;

FIG. 18 is a rear view of the ornamental design of FIG. 16;

FIG. 19 is a top plan view of the ornamental design of FIG. 16; and

FIG. 20 is a perspective view of a fifth embodiment of the communication tablet of FIG. 16 with the FIGS. 16–19 views being the same with the exception of the unclaimed stand; and,

FIG. 21 is an alternative perspective rear view of FIG. 20.

The broken lines shown in Embodiments 1 and 3 that are immediately adjacent to the claimed surfaces represent the bounds of the embodiment in which they are shown.

The broken lines shown in Embodiment 4 that are immediately adjacent to the claimed surfaces represent the bounds of the embodiment in which they are shown, while the broken line showing of the camera is directed to environment shown superimposed on a continuous surface.

The broken lines shown in Embodiments 2 and 5 that are immediately adjacent to the claimed surfaces represent the bounds of the embodiment in which they are shown, while the broken line showing of the stand is directed to environment.

All other broken lines are directed to environment and are for illustrative purposes only; the broken lines form no part of the embodiment in which they are shown.

1 Claim, 13 Drawing Sheets

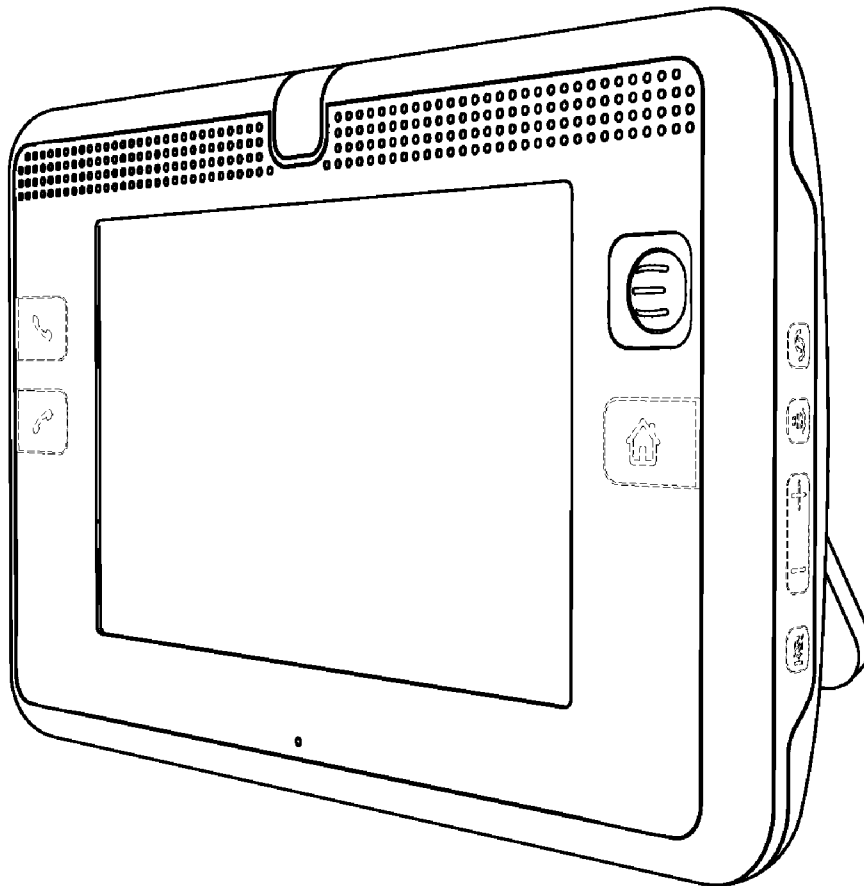

FIG. 1

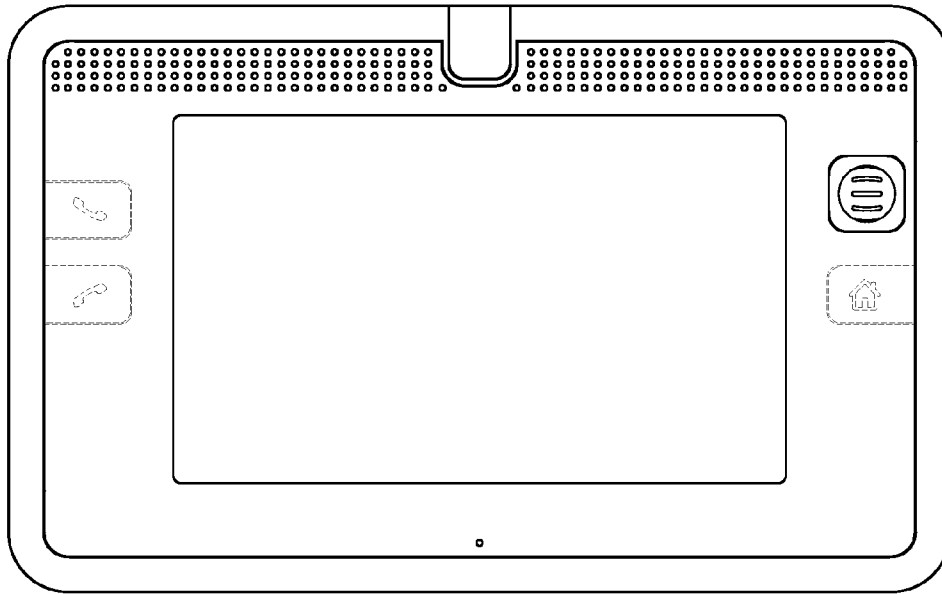

FIG. 2

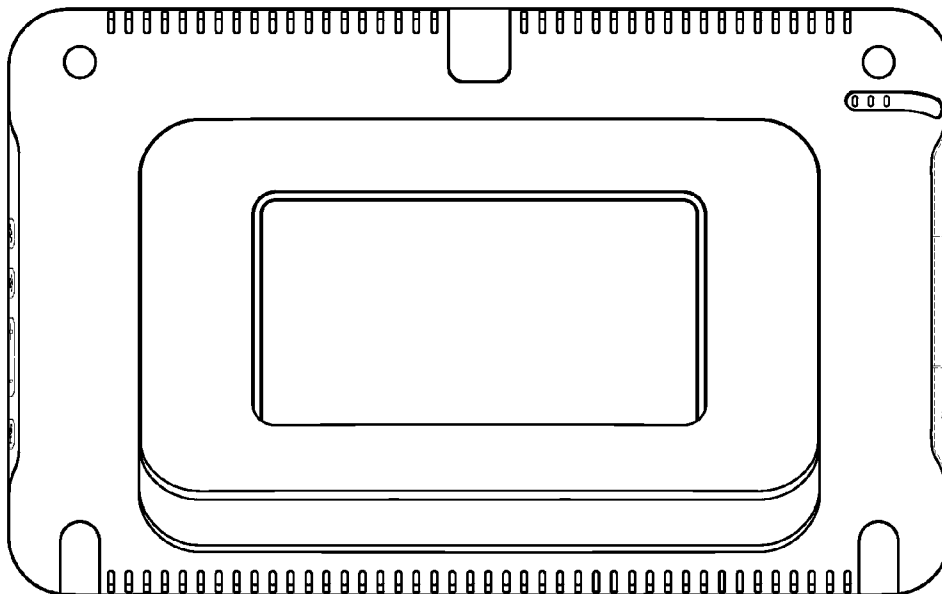

FIG. 3

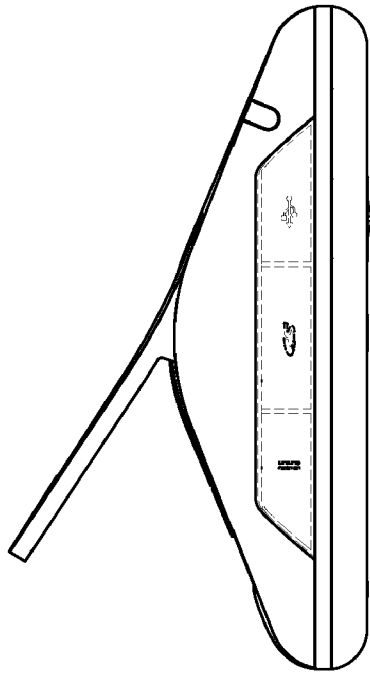

FIG. 4

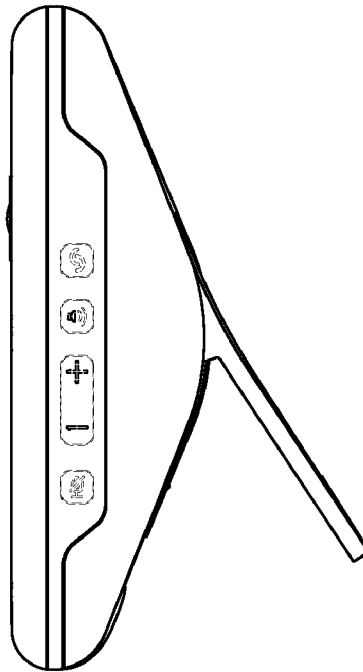

FIG. 5

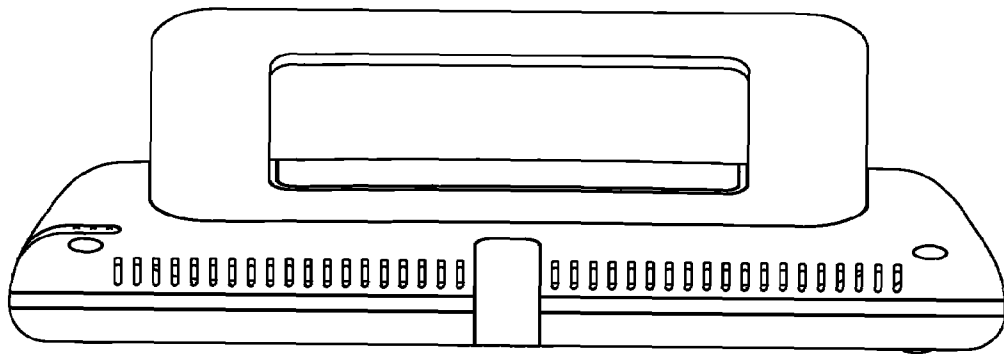

FIG. 6

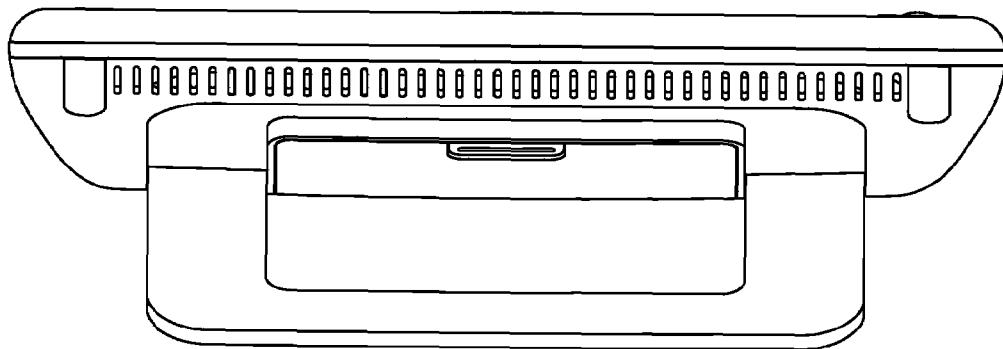

FIG. 7

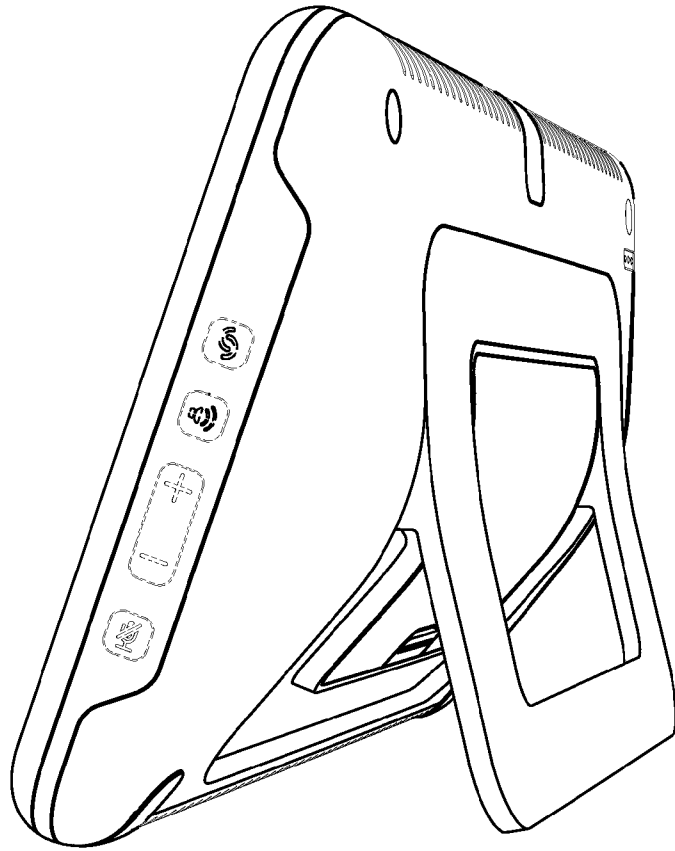

FIG. 8

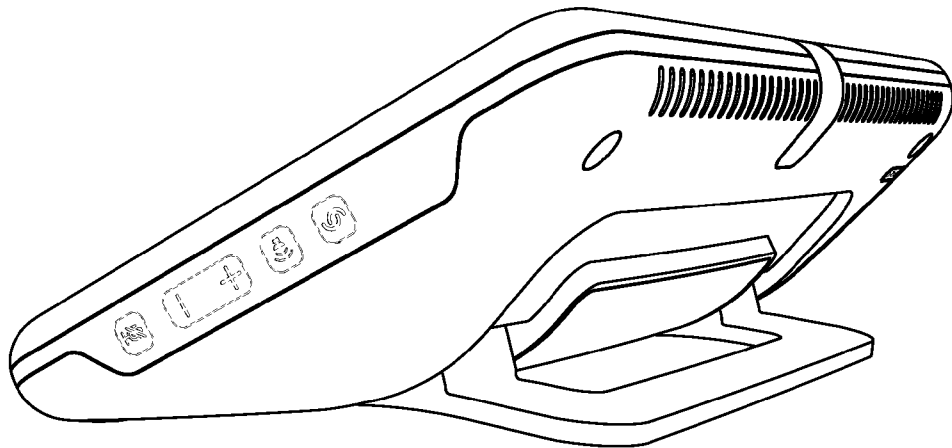

FIG. 9

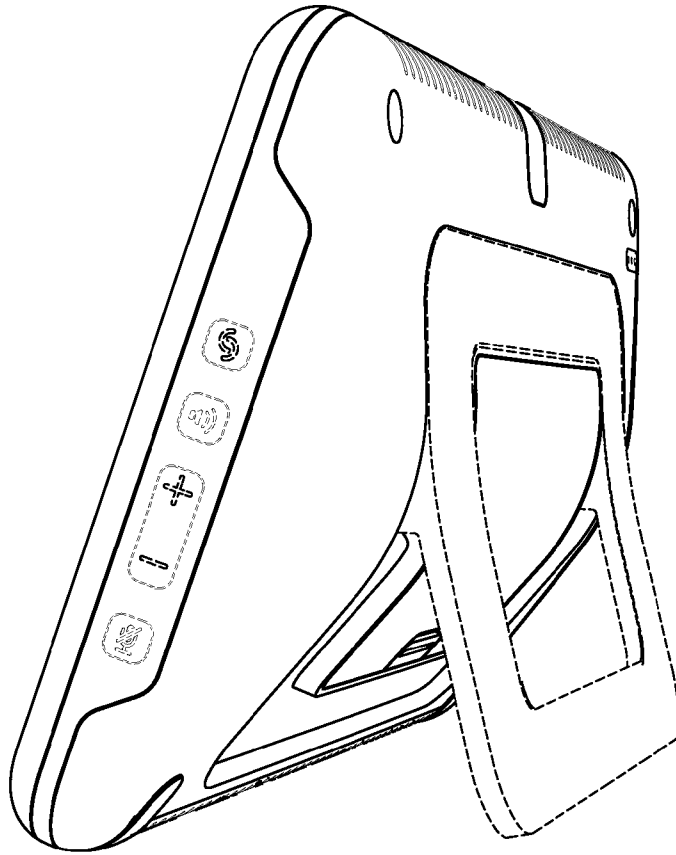

FIG. 10

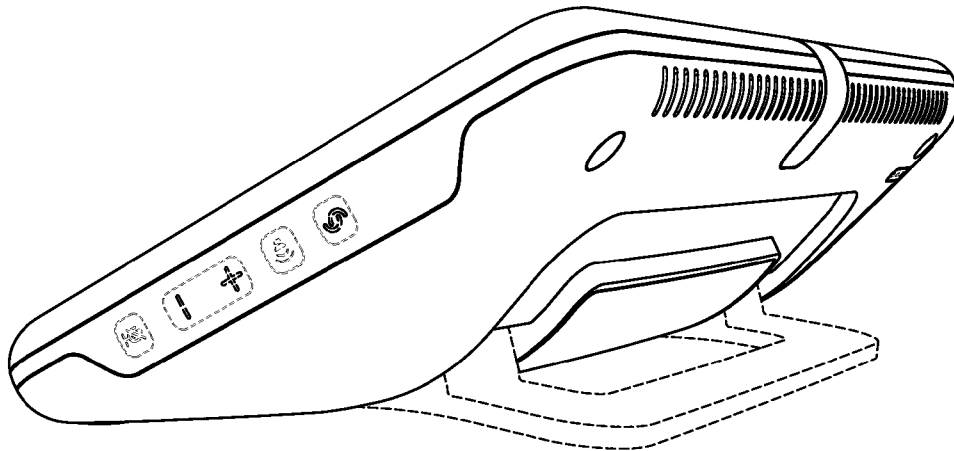

FIG. 11

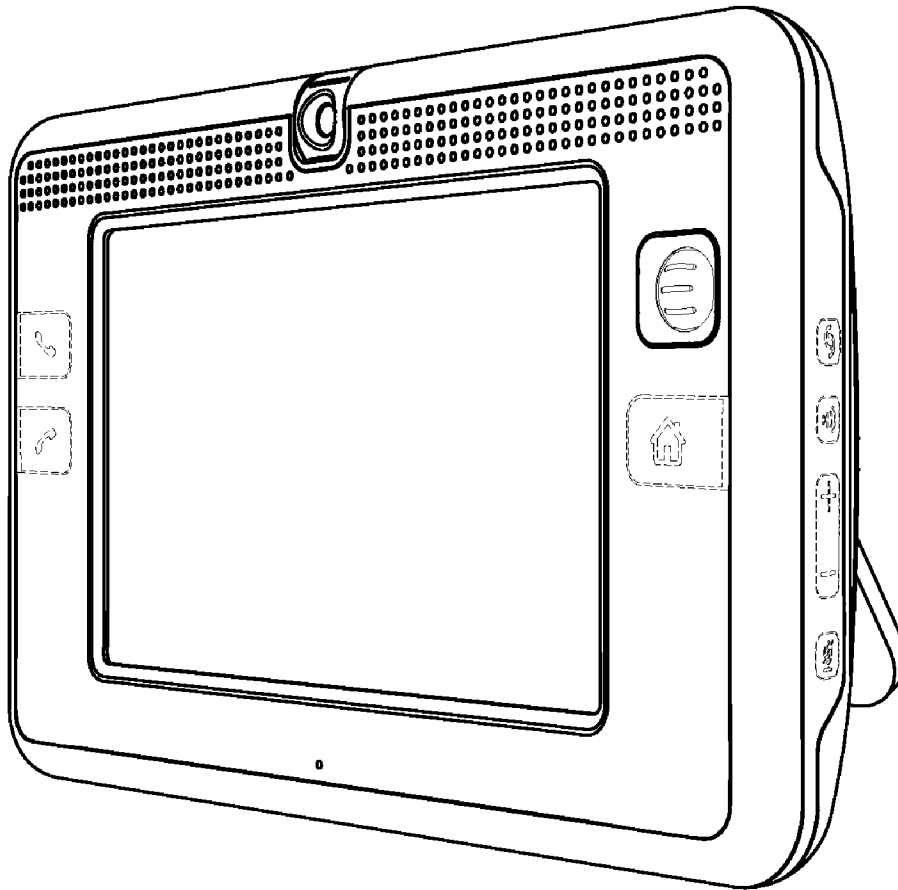

FIG. 12

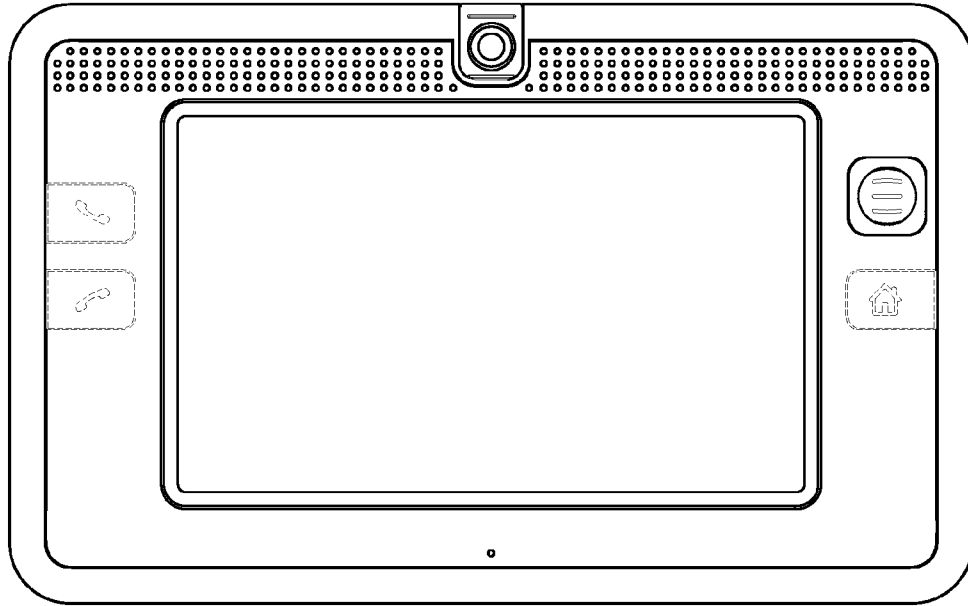

FIG. 13

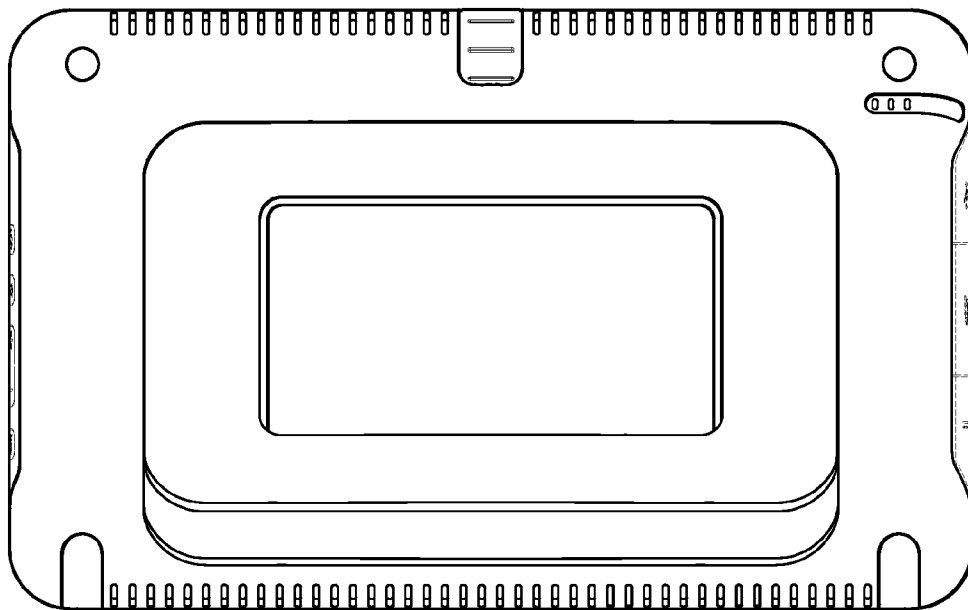

FIG. 14

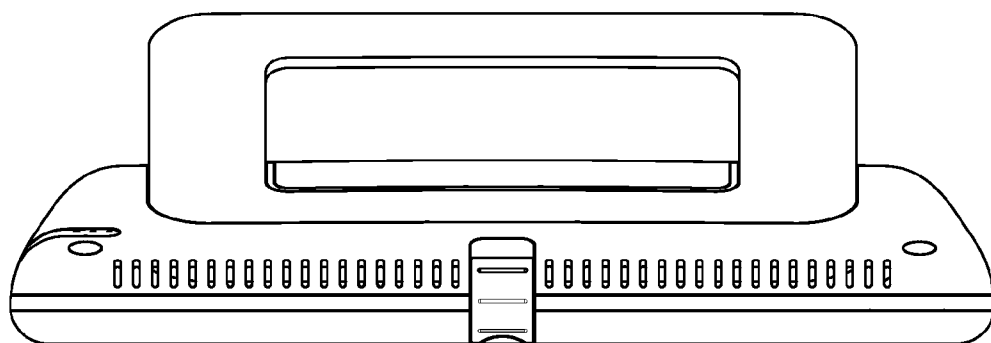

FIG. 15

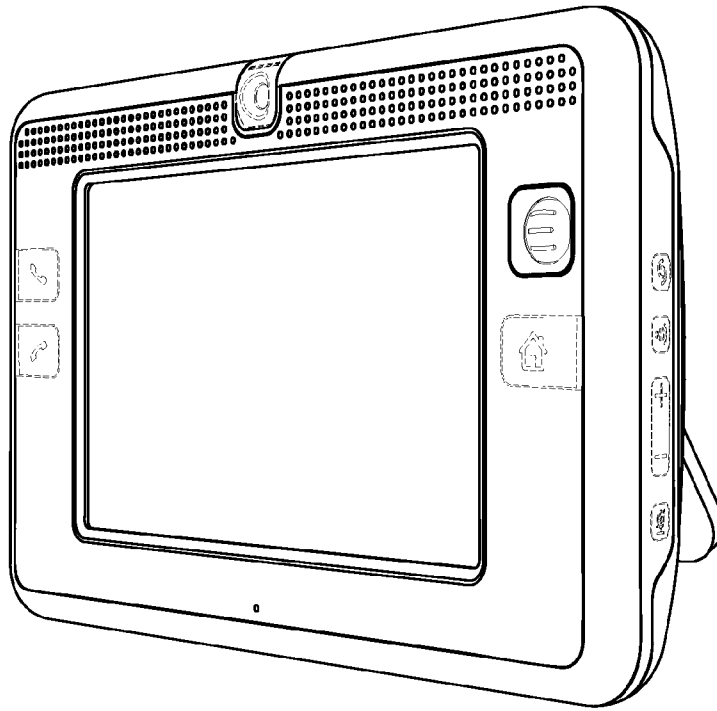

FIG. 16

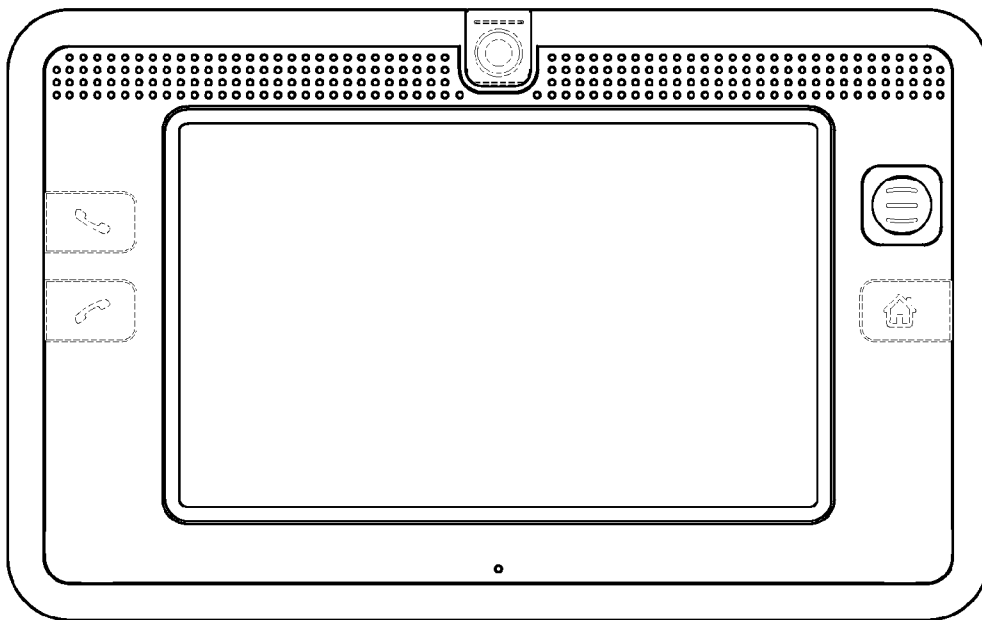

FIG. 17

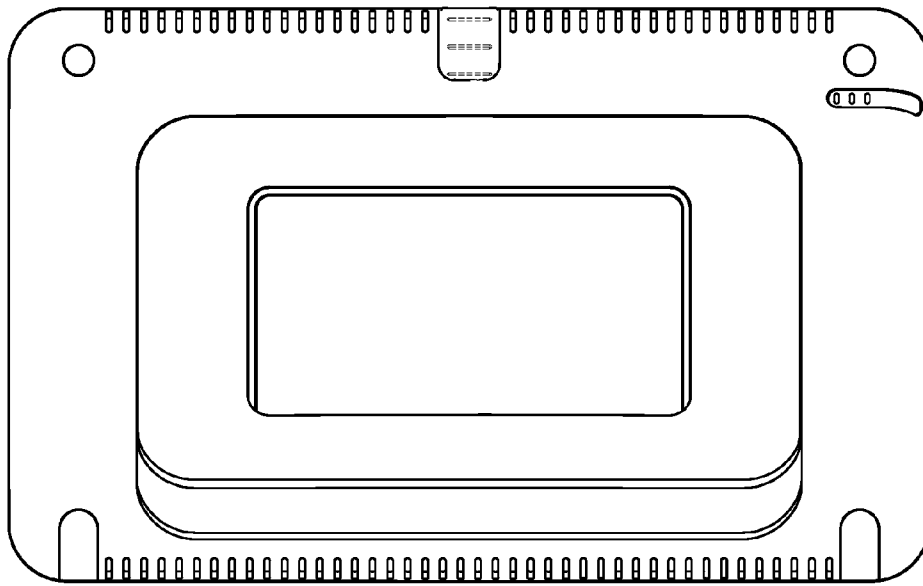

FIG. 18

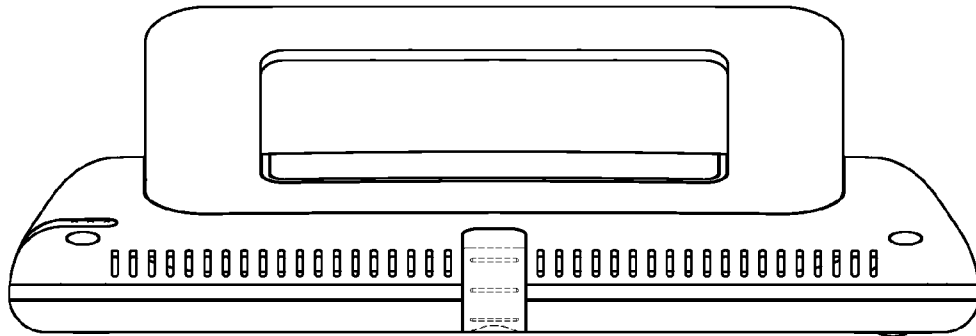

FIG. 19

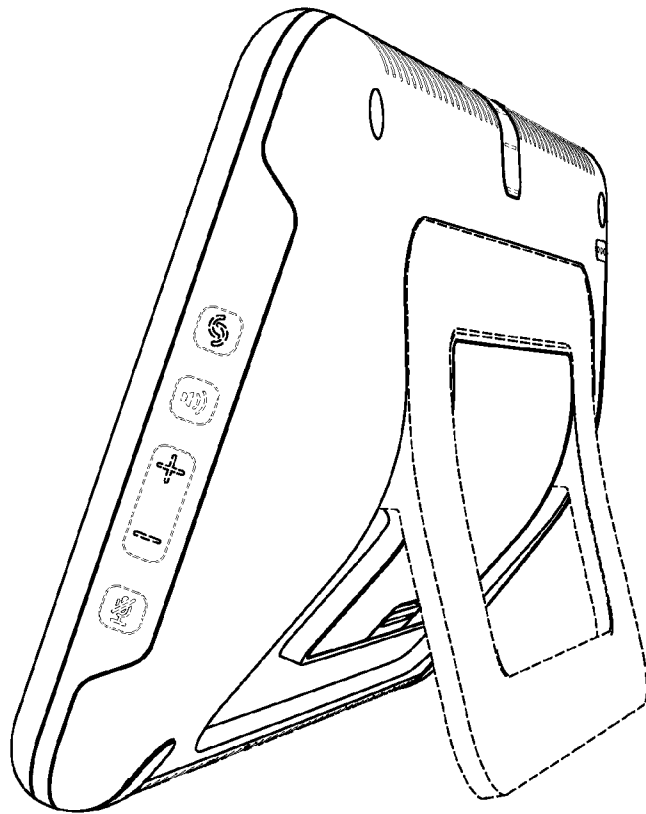

FIG. 20

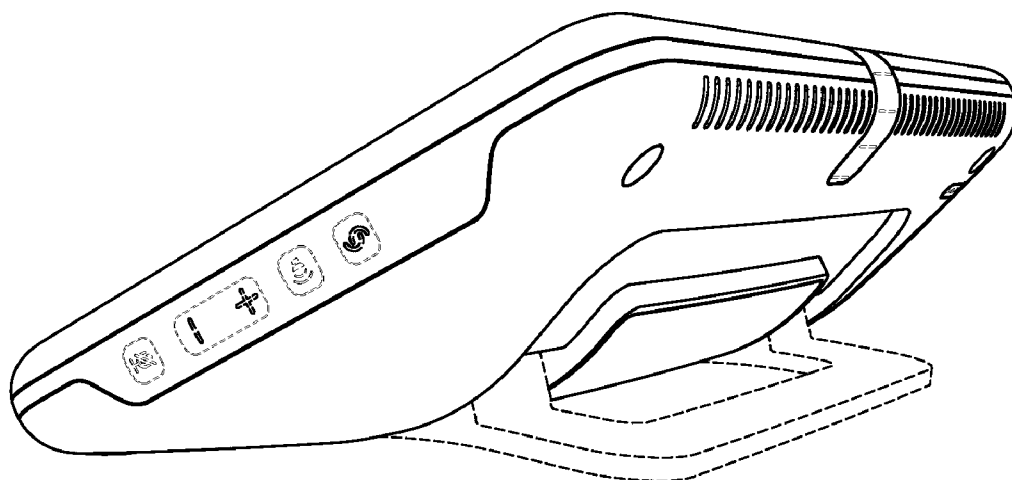

FIG.21