



US00D891569S

(12) **United States Design Patent** (10) **Patent No.:** **US D891,569 S**  
**Burrow et al.** (45) **Date of Patent:** **\*\* Jul. 28, 2020**

(54) **AMMUNITION CARTRIDGE NOSE HAVING AN ANGLED SHOULDER**

676,000 A 6/1901 Henneberg  
743,242 A 11/1903 Bush  
865,979 A 9/1907 Bailey  
869,046 A 10/1907 Bailey  
905,358 A 12/1908 Peters  
957,171 A 5/1910 Loeb  
963,911 A 7/1910 Loeble

(Continued)

(71) Applicant: **True Velocity IP Holdings, LLC,**  
Garland, TX (US)

(72) Inventors: **Lonnie Burrow,** Carrollton, TX (US);  
**Christopher William Overton,** Wylie,  
TX (US); **Nimmy Mammoottil,**  
Richardson, TX (US); **Florian Herzog,**  
Dallas, TX (US)

**FOREIGN PATENT DOCUMENTS**

CA 2813634 A1 4/2012  
CN 102901403 B 6/2014

(Continued)

(73) Assignee: **True Velocity IP Holdings, LLC,**  
Garland, TX (US)

**OTHER PUBLICATIONS**

AccurateShooter.com Daily Bulletin "New PolyCase Ammunition and Injection-Molded Bullets" Jan. 11, 2015.

*Primary Examiner* — Michael A. Pratt  
(74) *Attorney, Agent, or Firm* — Chainey P. Singleton

(\*\*) Term: **15 Years**

(21) Appl. No.: **29/683,248**

(22) Filed: **Mar. 12, 2019**

(51) **LOC (12) Cl.** ..... **22-16**

(52) **U.S. Cl.**  
USPC ..... **D22/116**

(58) **Field of Classification Search**  
USPC ..... D22/115–116  
See application file for complete search history.

(57) **CLAIM**

The ornamental design for an ammunition cartridge nose having an angled shoulder, as shown and described.

**DESCRIPTION**

FIG. 1 is an isometric view of an ammunition cartridge nose having an angled shoulder showing my new design of the nose portion of an ammunition cartridge.

FIG. 2 is a top view of my new design of the nose portion of an ammunition cartridge.

FIG. 3 is a cross sectional view along 3-3 of FIG. 2 showing my new design of the nose portion of an ammunition cartridge; and,

FIG. 4 is a cross sectional view along 4-4 of FIG. 2 showing my new design of the nose portion of an ammunition cartridge.

**1 Claim, 4 Drawing Sheets**

(56) **References Cited**

**U.S. PATENT DOCUMENTS**

99,528 A 2/1870 Boyd  
113,634 A 4/1871 Crispin  
130,679 A 8/1872 Whitmore  
159,665 A 2/1875 Gauthey  
169,807 A 11/1875 Hart  
207,248 A 8/1878 Bush et al.  
462,611 A 11/1891 Comte de Sparre  
475,008 A 5/1892 Bush  
498,856 A 6/1893 Overbaugh  
498,857 A 6/1893 Overbaugh  
640,856 A 1/1900 Bailey  
662,137 A 11/1900 Tellerson

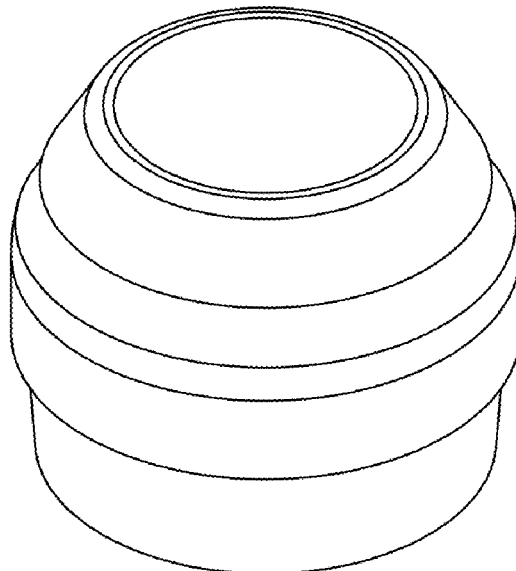

(56)

## References Cited

## U.S. PATENT DOCUMENTS

1,060,817	A	5/1913	Clyne	5,090,327	A	2/1992	Bilgeri
1,060,818	A	5/1913	Clyne	5,127,331	A	7/1992	Stoops
1,064,907	A	6/1913	Hoagland	5,151,555	A	9/1992	Vatsvog
1,187,464	A	6/1916	Offutt	5,165,040	A	11/1992	Andersson et al.
1,936,905	A	11/1933	Gaidos	5,237,930	A	8/1993	Belanger et al.
1,940,657	A	12/1933	Woodford	5,247,888	A	9/1993	Conil
2,294,822	A	9/1942	Norman	5,259,288	A	11/1993	Vatsvog
2,465,962	A	3/1949	Allen et al.	5,265,540	A	11/1993	Ducros et al.
2,654,319	A	10/1953	Roske	D345,676	S	4/1994	Biffle
2,823,611	A	2/1958	Thayer	5,433,148	A	7/1995	Barratault et al.
2,862,446	A	12/1958	Lars	5,535,495	A	7/1996	Gutowski
2,918,868	A	12/1959	Lars	5,563,365	A	10/1996	Dineen et al.
2,936,709	A	5/1960	Seavey	5,616,642	A	4/1997	West et al.
2,953,990	A	9/1960	Miller	D380,650	S	7/1997	Norris
2,972,947	A	2/1961	Fitzsimmons et al.	5,679,920	A	10/1997	Hallis et al.
3,034,433	A	5/1962	Karl	5,758,445	A	6/1998	Casull
3,099,958	A	8/1963	Daubenspeck et al.	5,770,815	A	6/1998	Watson
3,157,121	A	11/1964	Daubenspeck et al.	5,798,478	A	8/1998	Beal
3,159,701	A	12/1964	Herter	5,950,063	A	9/1999	Hens et al.
3,170,401	A	2/1965	Johnson et al.	5,961,200	A	10/1999	Friis
3,171,350	A	3/1965	Metcalf et al.	5,969,288	A	10/1999	Baud
3,242,789	A	3/1966	Woodring	5,979,331	A	11/1999	Casull
3,256,815	A	6/1966	Davidson et al.	6,004,682	A	12/1999	Rackovan et al.
3,288,066	A	11/1966	Hans et al.	6,048,379	A	4/2000	Bray et al.
3,292,538	A	12/1966	Hans et al.	6,070,532	A	6/2000	Halverson
3,332,352	A	7/1967	Olson et al.	D435,626	S	12/2000	Benini
3,444,777	A	5/1969	Lage	6,257,148	B1	7/2001	Toivonen et al.
3,446,146	A	5/1969	Stadler et al.	6,257,149	B1	7/2001	Cesaroni
3,485,170	A	12/1969	Scanlon	D447,209	S	8/2001	Benini
3,485,173	A	12/1969	Morgan	6,272,993	B1	8/2001	Cook et al.
3,491,691	A	1/1970	Vawter	6,283,035	B1	9/2001	Olson et al.
3,565,008	A	2/1971	Gulley et al.	6,357,357	B1	3/2002	Glasser
3,590,740	A	7/1971	Herter	D455,052	S	4/2002	Gullickson et al.
3,609,904	A	10/1971	Scanlon	D455,320	S	4/2002	Edelstein
3,614,929	A	10/1971	Herter et al.	6,375,971	B1	4/2002	Hansen
3,659,528	A	5/1972	Santala	6,408,764	B1	6/2002	Heitmann et al.
3,688,699	A	9/1972	Horn et al.	6,450,099	B1	9/2002	Desgland
3,690,256	A	9/1972	Schnitzer	6,460,464	B1	10/2002	Attarwala
3,745,924	A	7/1973	Scanlon	6,523,476	B1	2/2003	Riess et al.
3,749,021	A	7/1973	Burgess	6,644,204	B2	11/2003	Pierrot et al.
3,756,156	A	9/1973	Schuster	6,649,095	B2	11/2003	Buja
3,765,297	A	10/1973	Skochko et al.	6,672,219	B2	1/2004	Mackerell et al.
3,768,413	A	10/1973	Ramsay	6,708,621	B1	3/2004	Forichon-Chaumet et al.
3,797,396	A	3/1974	Reed	6,752,084	B1	6/2004	Husseini et al.
3,842,739	A	10/1974	Scanlon et al.	6,796,243	B2	9/2004	Schmees et al.
3,866,536	A	2/1975	Greenberg	6,810,816	B2	11/2004	Rennard
3,874,294	A	4/1975	Hale	6,840,149	B2	1/2005	Beal
3,955,506	A	5/1976	Luther et al.	6,845,716	B2	1/2005	Husseini et al.
3,977,326	A	8/1976	Anderson et al.	7,000,547	B2	2/2006	Amick
3,990,366	A	11/1976	Scanlon	7,014,284	B2	3/2006	Morton et al.
4,005,630	A	2/1977	Patrick	7,032,492	B2	4/2006	Meshirer
4,020,763	A	5/1977	Iruetagoyena	7,056,091	B2	6/2006	Powers
4,132,173	A	1/1979	Amuchastegui	7,059,234	B2	6/2006	Husseini
4,147,107	A	4/1979	Ringdal	7,165,496	B2	1/2007	Reynolds
4,157,684	A	6/1979	Clausser	D540,710	S	4/2007	Charrin
4,173,186	A	11/1979	Dunham	7,204,191	B2	4/2007	Wiley et al.
4,179,992	A	12/1979	Ramnarace et al.	7,213,519	B2	5/2007	Wiley et al.
4,187,271	A	2/1980	Rolston et al.	7,231,519	B2	6/2007	Joseph et al.
4,228,724	A	10/1980	Leich	7,232,473	B2	6/2007	Elliott
4,276,830	A	7/1981	Alice	7,299,750	B2	11/2007	Schikora et al.
4,353,304	A	10/1982	Hubsch et al.	7,353,756	B2	4/2008	Leasure
4,475,435	A	10/1984	Mantel	7,380,505	B1	6/2008	Shiery
4,483,251	A	11/1984	Spalding	7,383,776	B2	6/2008	Amick
4,598,445	A	7/1986	O'Connor	7,392,746	B2	7/2008	Hansen
4,614,157	A	9/1986	Grelle et al.	7,441,504	B2	10/2008	Husseini et al.
4,679,505	A	7/1987	Reed	D583,927	S	12/2008	Benner
4,718,348	A	1/1988	Ferrigno	7,458,322	B2	12/2008	Reynolds et al.
4,719,859	A	1/1988	Ballreich et al.	7,461,597	B2	12/2008	Brunn
4,726,296	A	2/1988	Leshner et al.	7,568,417	B1	8/2009	Lee
4,763,576	A	8/1988	Kass et al.	7,585,166	B2	9/2009	Buja
4,867,065	A	9/1989	Kaltmann et al.	7,610,858	B2	11/2009	Chung
4,970,959	A	11/1990	Bilsbury et al.	7,750,091	B2	7/2010	Maljkovic et al.
5,021,206	A	6/1991	Stoops	D626,619	S	11/2010	Gogol et al.
5,033,386	A	7/1991	Vatsvog	7,841,279	B2	11/2010	Reynolds et al.
5,063,853	A	11/1991	Bilgeri	D631,699	S	2/2011	Moreau
				D633,166	S	2/2011	Richardson et al.
				7,930,977	B2	4/2011	Klein
				8,007,370	B2	8/2011	Hirsch et al.
				8,056,232	B2	11/2011	Patel et al.

(56)

## References Cited

## U.S. PATENT DOCUMENTS

8,156,870	B2	4/2012	South	D779,024	S	2/2017	Burrow
8,186,273	B2	5/2012	Trivette	D780,283	S	2/2017	Burrow
8,201,867	B2	6/2012	Thomeczek	9,587,918	B1	3/2017	Burrow
8,206,522	B2	6/2012	Sandstrom et al.	9,599,443	B2	3/2017	Padgett et al.
8,240,252	B2	8/2012	Maljkovic et al.	9,625,241	B2	4/2017	Neugebauer
D675,882	S	2/2013	Crockett	9,631,907	B2	4/2017	Burrow
8,408,137	B2	4/2013	Battaglia	9,644,930	B1	5/2017	Burrow
D683,419	S	5/2013	Rebar	9,658,042	B2	5/2017	Emary
8,443,729	B2	5/2013	Mittelstaedt	9,683,818	B2	6/2017	Lemke et al.
8,443,730	B2	5/2013	Padgett	D792,200	S	7/2017	Baiz et al.
8,511,233	B2	8/2013	Nilsson	9,709,368	B2	7/2017	Mahnke
D689,975	S	9/2013	Carlson et al.	D797,880	S	9/2017	Seecamp
8,522,684	B2	9/2013	Davies et al.	9,759,554	B2	9/2017	Ng et al.
8,540,828	B2	9/2013	Busky et al.	D800,244	S	10/2017	Burczynski et al.
8,561,543	B2	10/2013	Burrow	D800,245	S	10/2017	Burczynski et al.
8,573,126	B2	11/2013	Klein et al.	D800,246	S	10/2017	Burczynski et al.
8,641,842	B2	2/2014	Hafner et al.	9,784,667	B2	10/2017	Lukay et al.
8,689,696	B1	4/2014	Seeman et al.	9,835,423	B2	12/2017	Burrow
8,763,535	B2	7/2014	Padgett	9,835,427	B2	12/2017	Burrow
8,790,455	B2	7/2014	Borissov et al.	9,857,151	B2	1/2018	Dionne et al.
8,807,008	B2	8/2014	Padgett et al.	9,869,536	B2	1/2018	Burrow
8,813,650	B2	8/2014	Maljkovic et al.	9,879,954	B2	1/2018	Hajjar
D715,888	S	10/2014	Padgett	9,885,551	B2	2/2018	Burrow
8,850,985	B2	10/2014	Maljkovic et al.	D813,975	S	3/2018	White
8,857,343	B2	10/2014	Marx	9,921,040	B2	3/2018	Rubin
8,869,702	B2	10/2014	Padgett	9,927,219	B2	3/2018	Burrow
D717,909	S	11/2014	Thrift et al.	9,933,241	B2	4/2018	Burrow
8,875,633	B2	11/2014	Padgett	9,939,236	B2	4/2018	Drobockyi et al.
8,893,621	B1	11/2014	Escobar	9,964,388	B1	5/2018	Burrow
8,978,559	B2	3/2015	Davies et al.	D821,536	S	6/2018	Christiansen et al.
9,003,973	B1	4/2015	Padgett	9,989,339	B2	6/2018	Riess
9,032,855	B1	5/2015	Foren et al.	10,041,770	B2	8/2018	Burrow
9,091,516	B2	7/2015	Davies et al.	10,041,771	B1	8/2018	Burrow
9,103,641	B2	8/2015	Nielson et al.	10,041,776	B1	8/2018	Burrow
9,157,709	B2	10/2015	Nuetzman et al.	10,041,777	B1	8/2018	Burrow
9,170,080	B2	10/2015	Poore et al.	10,048,049	B2	8/2018	Burrow
9,182,204	B2	11/2015	Maljkovic et al.	10,048,050	B1	8/2018	Burrow
9,188,412	B2	11/2015	Maljkovic et al.	10,048,052	B2	8/2018	Burrow
9,200,157	B2	12/2015	El-Hibri et al.	10,054,413	B1	8/2018	Burrow
9,200,880	B1	12/2015	Foren et al.	D828,483	S	9/2018	Burrow
9,212,876	B1	12/2015	Kostka et al.	10,081,057	B2	9/2018	Burrow
9,212,879	B2	12/2015	Whitworth	D832,037	S	10/2018	Gallagher
9,213,175	B2	12/2015	Arnold	10,101,140	B2	10/2018	Burrow
9,254,503	B2	2/2016	Ward	10,124,343	B2	11/2018	Tsai
9,255,775	B1	2/2016	Rubin	10,145,662	B2	12/2018	Burrow
D752,397	S	3/2016	Seiders et al.	10,190,857	B2	1/2019	Burrow
D754,223	S	4/2016	Pederson et al.	10,234,249	B2	3/2019	Burrow
9,329,004	B2	5/2016	Pace	10,234,253	B2	3/2019	Burrow
9,335,137	B2	5/2016	Maljkovic et al.	10,240,905	B2	3/2019	Burrow
9,337,278	B1	5/2016	Gu et al.	10,254,096	B2	4/2019	Burrow
9,347,457	B2	5/2016	Ahrens et al.	10,260,847	B2	4/2019	Viggiano et al.
9,366,512	B2	6/2016	Burczynski et al.	D849,181	S	5/2019	Burrow
9,377,278	B2	6/2016	Rubin	10,302,403	B2	5/2019	Burrow
9,389,052	B2	7/2016	Conroy et al.	10,302,404	B2	5/2019	Burrow
9,395,165	B2	7/2016	Maljkovic et al.	10,330,451	B2	6/2019	Burrow
D764,624	S	8/2016	Masinelli	10,345,088	B2	7/2019	Burrow
D765,214	S	8/2016	Padgett	10,352,664	B2	7/2019	Burrow
9,429,407	B2	8/2016	Burrow	10,352,670	B2	7/2019	Burrow
9,441,930	B2	9/2016	Burrow	10,359,262	B2	7/2019	Burrow
9,453,714	B2	9/2016	Bosarge et al.	10,365,074	B2	7/2019	Burrow
D773,009	S	11/2016	Bowers	D861,118	S	9/2019	Burrow
9,500,453	B2	11/2016	Schluckebier et al.	D861,119	S	9/2019	Burrow
9,506,735	B1	11/2016	Burrow	10,408,582	B2	9/2019	Burrow
D774,824	S	12/2016	Gallagher	10,408,592	B2	9/2019	Boss et al.
9,513,096	B2	12/2016	Burrow	10,415,943	B2	9/2019	Burrow
9,518,810	B1	12/2016	Burrow	10,429,156	B2	10/2019	Burrow
9,523,563	B1	12/2016	Burrow	10,458,762	B2	10/2019	Burrow
9,528,799	B2	12/2016	Maljkovic	10,466,020	B2	11/2019	Burrow
9,546,849	B2	1/2017	Burrow	10,466,021	B2	11/2019	Burrow
9,551,557	B1	1/2017	Burrow	10,480,911	B2	11/2019	Burrow
D778,391	S	2/2017	Burrow	10,480,912	B2	11/2019	Burrow
D778,393	S	2/2017	Burrow	10,480,915	B2	11/2019	Burrow et al.
D778,394	S	2/2017	Burrow	10,488,165	B2	11/2019	Burrow
D778,395	S	2/2017	Burrow	10,533,830	B2	1/2020	Burrow et al.
D779,021	S	2/2017	Burrow	2003/0127011	A1	7/2003	Mackerell et al.
				2004/0074412	A1	4/2004	Kightlinger
				2004/0200340	A1	10/2004	Robinson et al.
				2005/0056183	A1	3/2005	Meshirer
				2005/0081704	A1	4/2005	Husseini

(56)

References Cited

U.S. PATENT DOCUMENTS

2005/0257712 A1 11/2005 Husseini et al.  
 2006/0027125 A1 2/2006 Brunn  
 2006/0278116 A1 12/2006 Hunt  
 2006/0283345 A1 12/2006 Feldman et al.  
 2007/0056343 A1 3/2007 Cremonesi  
 2007/0181029 A1 8/2007 Mcaninch  
 2007/0214992 A1 9/2007 Dittrich  
 2007/0214993 A1 9/2007 Cerovic et al.  
 2007/0267587 A1 11/2007 Dalluge  
 2010/0101444 A1 4/2010 Schluckebier et al.  
 2010/0212533 A1 8/2010 Brunn  
 2010/0234132 A1 9/2010 Hirsch et al.  
 2010/0258023 A1 10/2010 Reynolds et al.  
 2010/0282112 A1 11/2010 Battaglia  
 2011/0179965 A1 7/2011 Mason  
 2012/0024183 A1 2/2012 Klein  
 2012/0111219 A1 5/2012 Burrow  
 2012/0180685 A1 7/2012 Se-Hong  
 2012/0180687 A1 7/2012 Padgett et al.  
 2012/0180688 A1\* 7/2012 Padgett ..... F42B 5/313  
 102/466  
 2012/0291655 A1 11/2012 Jones  
 2013/0008335 A1 1/2013 Menefee  
 2013/0014664 A1\* 1/2013 Padgett ..... F42B 5/313  
 102/439  
 2013/0076865 A1 3/2013 Tateno et al.  
 2013/0186294 A1 7/2013 Davies et al.  
 2013/0291711 A1 11/2013 Mason  
 2014/0224144 A1 8/2014 Neugebauer  
 2014/0260925 A1 9/2014 Beach et al.  
 2014/0261044 A1 9/2014 Seecamp  
 2014/0311332 A1 10/2014 Carlson et al.  
 2015/0075400 A1 3/2015 Lemke et al.  
 2015/0226220 A1 8/2015 Bevington  
 2015/0268020 A1 9/2015 Emary  
 2016/0003585 A1 1/2016 Carpenter et al.  
 2016/0003588 A1\* 1/2016 Burrow ..... C22C 33/0257  
 102/466  
 2016/0003589 A1 1/2016 Burrow  
 2016/0003590 A1 1/2016 Burrow  
 2016/0003593 A1 1/2016 Burrow  
 2016/0003594 A1 1/2016 Burrow  
 2016/0003595 A1 1/2016 Burrow  
 2016/0003596 A1 1/2016 Burrow  
 2016/0003597 A1 1/2016 Burrow  
 2016/0003601 A1 1/2016 Burrow  
 2016/0033241 A1 2/2016 Burrow  
 2016/0102030 A1 4/2016 Coffey et al.  
 2016/0146585 A1 5/2016 Padgett  
 2016/0245626 A1 8/2016 Drieling et al.  
 2016/0265886 A1 9/2016 Aldrich et al.  
 2016/0349022 A1\* 12/2016 Burrow ..... F42B 5/307  
 2016/0349023 A1 12/2016 Burrow  
 2016/0349028 A1 12/2016 Burrow  
 2016/0356588 A1 12/2016 Burrow  
 2016/0377399 A1 12/2016 Burrow  
 2017/0030690 A1 2/2017 Viggiano et al.  
 2017/0030692 A1 2/2017 Drobockyi et al.  
 2017/0080498 A1 3/2017 Burrow  
 2017/0082409 A1 3/2017 Burrow  
 2017/0082411 A1 3/2017 Burrow  
 2017/0089673 A1 3/2017 Burrow  
 2017/0089674 A1 3/2017 Burrow  
 2017/0089675 A1 3/2017 Burrow  
 2017/0089679 A1 3/2017 Burrow  
 2017/0115105 A1 4/2017 Burrow  
 2017/0153093 A9 6/2017 Burrow  
 2017/0153099 A9 6/2017 Burrow  
 2017/0191812 A1 7/2017 Padgett et al.  
 2017/0199018 A9 7/2017 Burrow  
 2017/0205217 A9 7/2017 Burrow  
 2017/0261296 A1 9/2017 Burrow  
 2017/0299352 A9 10/2017 Burrow  
 2018/0066925 A1 3/2018 Skowron et al.  
 2018/0106581 A1 4/2018 Rogers

2018/0224252 A1 8/2018 O'Rourke  
 2018/0224253 A1 8/2018 Burrow  
 2018/0224256 A1 8/2018 Burrow  
 2018/0259310 A1 9/2018 Burrow  
 2018/0292186 A1 10/2018 Padgett et al.  
 2018/0306558 A1 10/2018 Padgett et al.  
 2018/0321023 A1\* 11/2018 Teig ..... F42B 12/02  
 2019/0011232 A1\* 1/2019 Boss ..... F42C 19/0807  
 2019/0011233 A1 1/2019 Boss et al.  
 2019/0011234 A1 1/2019 Boss et al.  
 2019/0011235 A1 1/2019 Boss et al.  
 2019/0011236 A1 1/2019 Burrow  
 2019/0011237 A1 1/2019 Burrow  
 2019/0011238 A1 1/2019 Burrow  
 2019/0011239 A1 1/2019 Burrow  
 2019/0011240 A1 1/2019 Burrow  
 2019/0011241 A1 1/2019 Burrow  
 2019/0025019 A1 1/2019 Burrow  
 2019/0025020 A1 1/2019 Burrow  
 2019/0025021 A1 1/2019 Burrow  
 2019/0025022 A1 1/2019 Burrow  
 2019/0025023 A1 1/2019 Burrow  
 2019/0025024 A1 1/2019 Burrow  
 2019/0025025 A1 1/2019 Burrow  
 2019/0025026 A1 1/2019 Burrow  
 2019/0025035 A1 1/2019 Burrow  
 2019/0025036 A1 1/2019 Burrow  
 2019/0078862 A1 3/2019 Burrow  
 2019/0106364 A1 4/2019 James  
 2019/0107375 A1 4/2019 Burrow  
 2019/0137228 A1 5/2019 Burrow et al.  
 2019/0137229 A1 5/2019 Burrow et al.  
 2019/0137230 A1 5/2019 Burrow et al.  
 2019/0137231 A1 5/2019 Burrow et al.  
 2019/0137232 A1 5/2019 Burrow et al.  
 2019/0137233 A1 5/2019 Burrow et al.  
 2019/0137234 A1 5/2019 Burrow et al.  
 2019/0137235 A1 5/2019 Burrow et al.  
 2019/0137236 A1 5/2019 Burrow et al.  
 2019/0137237 A1 5/2019 Burrow et al.  
 2019/0137238 A1 5/2019 Burrow et al.  
 2019/0137239 A1 5/2019 Burrow et al.  
 2019/0137240 A1 5/2019 Burrow et al.  
 2019/0137241 A1 5/2019 Burrow et al.  
 2019/0137242 A1 5/2019 Burrow et al.  
 2019/0137243 A1 5/2019 Burrow et al.  
 2019/0137244 A1 5/2019 Burrow et al.  
 2019/0170488 A1 6/2019 Burrow  
 2019/0204050 A1 7/2019 Burrow  
 2019/0204056 A1 7/2019 Burrow  
 2019/0212117 A1 7/2019 Burrow  
 2019/0242679 A1 8/2019 Viggiano et al.  
 2019/0242682 A1 8/2019 Burrow  
 2019/0242683 A1 8/2019 Burrow  
 2019/0249967 A1 8/2019 Burrow et al.  
 2019/0257625 A1 8/2019 Burrow  
 2019/0310058 A1 10/2019 Burrow  
 2019/0310059 A1 10/2019 Burrow  
 2019/0316886 A1 10/2019 Burrow  
 2019/0360788 A1 11/2019 Burrow  
 2019/0376773 A1 12/2019 Burrow  
 2019/0376774 A1 12/2019 Boss et al.  
 2019/0383590 A1 12/2019 Burrow  
 2020/0011645 A1 1/2020 Burrow et al.  
 2020/0011646 A1 1/2020 Burrow et al.  
 2020/0025536 A1 1/2020 Burrow et al.  
 2020/0025537 A1 1/2020 Burrow et al.

FOREIGN PATENT DOCUMENTS

DE 16742 C 1/1882  
 EP 2625486 A4 8/2017  
 FR 1412414 A 10/1965  
 GB 183023 A 9/1957  
 RU 2172467 C1 8/2001  
 WO 0034732 6/2000  
 WO 2007014024 A2 2/2007  
 WO 2012047615 A1 4/2012  
 WO 2012097320 A1 7/2012

(56)

**References Cited**

FOREIGN PATENT DOCUMENTS

WO	2012097317	A3	11/2012
WO	2013070250	A1	5/2013
WO	2013096848	A1	6/2013
WO	2014062256	A2	4/2014
WO	2016003817	A1	1/2016
WO	2019094544	A1	5/2019
WO	2019160742	A2	8/2019

\* cited by examiner

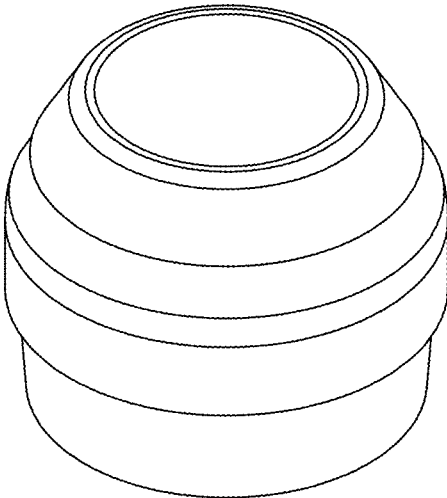

FIG. 1

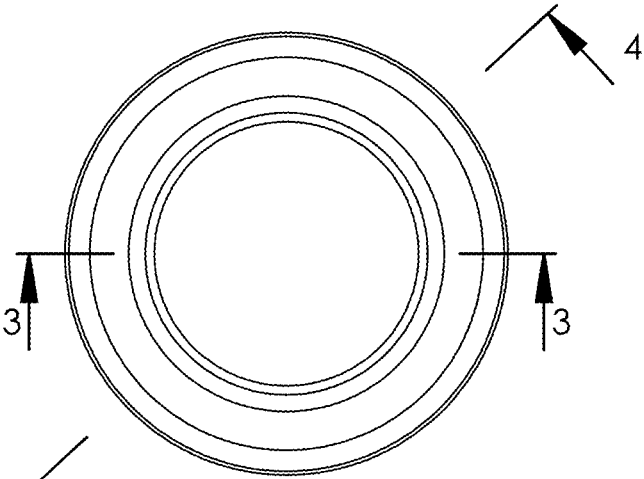

FIG. 2

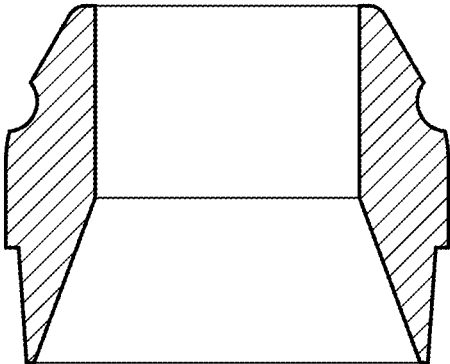

FIG. 3



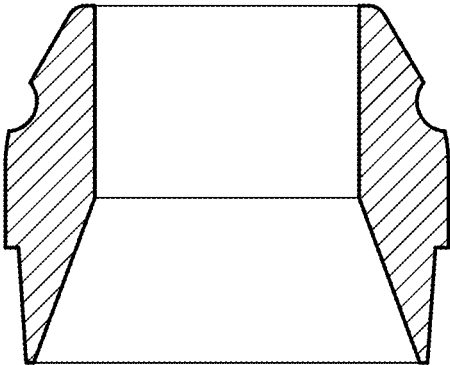

FIG. 4