



(43) International Publication Date
13 August 2015 (13.08.2015)

(51) International Patent Classification:

B01F 15/04 (2006.01) *G01J 3/46* (2006.01)
B29C 47/92 (2006.01) *G05D 25/00* (2006.01)
C08J 3/22 (2006.01) *B29B 7/72* (2006.01)

(21) International Application Number:

PCT/IL2015/050130

(22) International Filing Date:

5 February 2015 (05.02.2015)

(25) Filing Language:

English

(26) Publication Language:

English

(30) Priority Data:

230879 6 February 2014 (06.02.2014) IL

(71) Applicant: **O.E.D.A. LIAD HOLDINGS (2006) LTD.**
[IL/IL]; Sky Street, 2017900 Misgav Industrial Park (IL).

(72) Inventors: **REGELMAN, Vadim (Dan)**; 6/6 Tavor Street,
2701342 Kiryat Bialik (IL). **MARGALIT, Eli**; 2015500
Moshav Yaad (IL). **HOFMANN, Daniel**; 30 Yefe Nof
Street, 3437120 Haifa (IL). **JACOBOVICH, Ofer**; 20
Hashalva Street, 4062420 Tel Mond (IL). **ADANI, Aviad**;
2015500 Moshav Yad (IL).

(74) Agents: **ALPERT, Bruce** et al.; Luzzatto & Luzzatto, P.O.
Box 5352, 8415202 Beer Sheva (IL).

(81) Designated States (unless otherwise indicated, for every kind of national protection available): AE, AG, AL, AM, AO, AT, AU, AZ, BA, BB, BG, BH, BN, BR, BW, BY, BZ, CA, CH, CL, CN, CO, CR, CU, CZ, DE, DK, DM, DO, DZ, EC, EE, EG, ES, FI, GB, GD, GE, GH, GM, GT, HN, HR, HU, ID, IL, IN, IR, IS, JP, KE, KG, KN, KP, KR, KZ, LA, LC, LK, LR, LS, LU, LY, MA, MD, ME, MG, MK, MN, MW, MX, MY, MZ, NA, NG, NI, NO, NZ, OM, PA, PE, PG, PH, PL, PT, QA, RO, RS, RU, RW, SA, SC, SD, SE, SG, SK, SL, SM, ST, SV, SY, TH, TJ, TM, TN, TR, TT, TZ, UA, UG, US, UZ, VC, VN, ZA, ZM, ZW.

(84) Designated States (unless otherwise indicated, for every kind of regional protection available): ARIPO (BW, GH, GM, KE, LR, LS, MW, MZ, NA, RW, SD, SL, ST, SZ, TZ, UG, ZM, ZW), Eurasian (AM, AZ, BY, KG, KZ, RU, TJ, TM), European (AL, AT, BE, BG, CH, CY, CZ, DE, DK, EE, ES, FI, FR, GB, GR, HR, HU, IE, IS, IT, LT, LU, LV, MC, MK, MT, NL, NO, PL, PT, RO, RS, SE, SI, SK, SM, TR), OAPI (BF, BJ, CF, CG, CI, CM, GA, GN, GQ, GW, KM, ML, MR, NE, SN, TD, TG).

Declarations under Rule 4.17:

— of inventorship (Rule 4.17(iv))

Published:

— with international search report (Art. 21(3))

(54) Title: SPECTRAL PROPERTIES-BASED SYSTEM AND METHOD FOR FEEDING MASTERBATCHES INTO A PLASTIC PROCESSING MACHINE

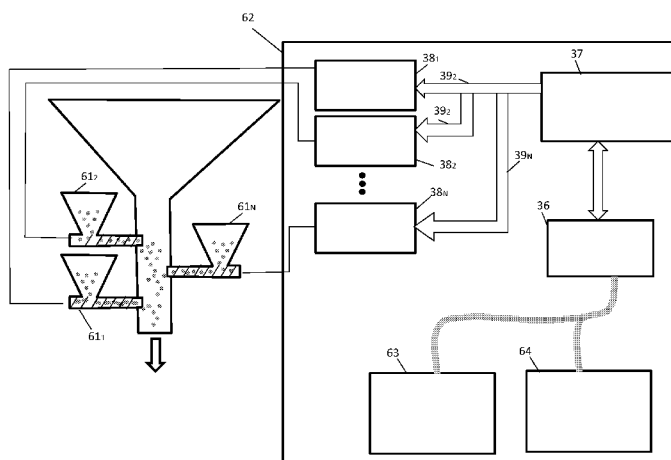

Fig. 6

(57) Abstract: A method and system for optimizing a match between the color of an in-line part manufactured by a plastic product production machine and the color of a reference part by adjusting the concentration of masterbatch in the mixture of raw material fed to the plastic product production machine. The optimization of the color is based on spectra of the in-line part and reference part obtained within a short time interval using the same spectrometer, thereby eliminating the requirement for high accuracy spectrometer calibration and allowing the method, which determines the rates at which the base masterbatches are added to the raw material, to be carried out in real time on the manufacturing floor while the plastic product production machine is being operated to manufacture in-line parts.

WO 2015/118535 A1

- 1 -

**SPECTRAL PROPERTIES-BASED SYSTEM AND METHOD FOR
FEEDING MASTERBATCHES INTO A PLASTIC PROCESSING
MACHINE**

5 **Field of the invention**

The present invention relates to the dispensing of additive material into plastic processing machines in the plastics industry. In particular, the present invention discloses a method and system for optimizing the amount of fed color additive materials (color masterbatches) by in-line measurement
10 of the molded product spectral properties, comparing them to a reference material and controlling the feeding device of the dispensing system by using the signal obtained from the comparison and the processing of spectral properties.

Background of Invention

15 In the modern world, plastics are the material of choice for the manufacture of a seemingly unlimited number of products. These products are produced by a variety of industrial processes, e.g. injection molding, blow molding, extrusion, and 3-D printers. The raw material that is fed into the machines used to produce the final products is a mixture consisting of: polymers
20 (called resin or virgin in the industry) in the form of small beads, colorants and other additives, e.g. UV inhibitors. The colorants and other additives are supplied as masterbatches, which are concentrated mixtures of pigments and/or additives encapsulated during a heat process into a carrier resin which is then cooled and cut into a granular shape.

25 Herein the term "masterbatch" is used to refer to a masterbatch that contain pigment, i.e. color masterbatch, and the term "base material" is used to refer to polymers or mixtures of polymers.

- 2 -

Herein the term "screw" is used to refer to a screw, dosing mechanism, auger, belt conveyer, or vibratory mechanism of the dispensing system

In order to dispense the required amount of the additives material – mainly color masterbatch – to be mixed with the base material volumetric or gravimetric are commonly utilized. One or more such feeders are installed on the throat of the plastic processing machine.

The volumetric system releases a pre-defined volume of additive/masterbatch into the mixing machine. The advantage of this system is implementation simplicity by using a feeding screw, where the released volume is calibrated to the screw rotation speed. This method compromises accuracy for simplicity, since the exact weight (calculated to be volume multiplied by density) of the released masterbatch material for the same rotation speed varies with the masterbatch density, granule size and other parameters.

US 5,103,401, US 6,688,493B2 and US 6,966,456B2 describe gravimetric methods. The gravimetric methods add a weighing mechanism with a control system to the feeding screw, and then, periodically the exact weight of the released material is measured. The difference between the actual weight and the set point is used as the error signal for the control electronics. The gravimetric method has much greater accuracy compared to the volumetric method, resulting in saving of masterbatch material. A gravimetric system allows the material to be released exactly in the amount defined by the set point, usually defined in mass per time unit or percent of the base material. A prior art gravimetric system is shown schematically in Fig. 1.

In both the volumetric and gravimetric cases the masterbatch material set point is defined empirically and no actual measurements of the properties of the mixture are made in-line to confirm/adjust it.

- 3 -

Precision color measurement based on optical spectrum is an extremely challenging process, since fractions of percent of calibration accuracy are required in order to achieve color accuracy better than the color resolution of the human eye.

- 5 It is therefore an object of the present invention to provide a method and a system for adjusting and controlling the masterbatch release rate according to an in-line measurement of spectral properties of a product to fit a pre-defined spectral signature of a given reference sample.

Summary of the Invention

- 10 In a first aspect the invention is a method for optimizing a match between the color of an in-line part manufactured by a plastic product production machine and the color of a reference part by adjusting the concentration of masterbatch in the mixture of raw material fed to the plastic product production machine. The method comprises:
- 15 a. measuring the spectrum of the in-line part with a spectrometer;
- b. measuring the spectrum of the reference part with a spectrometer;
- c. determining the color coordinates of the in-line part and the reference part from the spectra measured in steps a and b;
- d. determining the color coordinates of a set point, which corresponds to
20 the lowest concentration of masterbatch required to make the color of the in-line part indistinguishable to the human eye from the color of the reference part;
- e. determining the distance ΔE between the color coordinates of the in-line part and the color coordinates of a set point determined in step d;

- 4 -

f. determining a signal for controlling the feed speed of the mechanism that adds masterbatch to the mixture of raw material fed to the plastic product production machine; and

5 g. controlling the feed speed of the mechanism that adds masterbatch to the mixture of raw material fed to the plastic product production machine by means of the signal determined in step f.

Steps a and b are carried out within a short time interval using the same spectrometer, thereby eliminating the requirement for high accuracy spectrometer calibration and allowing steps a to g of the method to be
10 carried out in real time on a manufacturing floor while the plastic product production machine is being operated to manufacture in-line parts.

In embodiments of the method of the invention the set point is the lowest saturation point on the MacAdam ellipse around the reference material sample color. The set point can be found in one of the following ways:

- 15 a. by maximizing the distance from the boundaries of the chromaticity diagram;
- b. by minimizing the distance from the color coordinates of the in-line part to the white center point 223; and
- 20 c. by mathematical definition of saturation (S) value by transformation from xyY color space into the HSV color space.

In embodiments of the method of the invention the set point is determined by means of an iterative process.

In embodiments of the method of the invention the distance ΔE between the in-line color part and the set point on the chromaticity diagram is
25 determined using the CIEDE2000 formula.

- 5 -

In embodiments of the method of the invention the signal for controlling the feed speed of the mechanism that adds masterbatch to the mixture of raw material fed to the plastic product production machine is defined as

$$Err = \Delta E * f(S_0 - S),$$

5 where S_0 and S are saturation values of the reference sample and the in-line part colors respectively, and $f(S_0 - S) = f(x)$ is a weighting function.

In embodiments of the method of the invention the color of the in-line part is determined by the combination of three base masterbatches and the signals for controlling the feed speed of the mechanism that adds masterbatch to the mixture of raw material fed to the plastic product production machine are determined by projecting the ΔE vector on the axes defined by vectors connecting the locations of the base masterbatches on the chromaticity diagram.

In a second aspect the invention is a system for controlling the concentration of at least one base masterbatch in the mixture of raw material fed to a plastic product production machine in order to optimize the match of the color of an in-line part manufactured by the plastic product production machine to the color of a reference part. The system comprises:

- a. at least one white light source;
- 20 b. at least one measurement head for configured for measuring the spectrum of an in-line part;
- c. at least one measurement head configured for measuring the spectrum a reference part;
- d. a spectrometer;
- 25 e. a network adapted to provide illumination light from the at least one light source to each of the measurement heads;

- 6 -

- f. an optical network to guide return light that is either reflected from the surface of or transmitted through the in-line and reference parts from each of the measurement heads to the spectrometer;
- 5 g. a spectrum processing and control unit configured to receive electric signals representative of the spectra of the in-line and reference parts from the spectrometer, to process the signals and to determine error signals that are sent to at least one feed controller;
- 10 h. at least one feed controller for each base masterbatch, each feed controller configured to receive an error signal from the spectrum processing and control unit and to send it to a masterbatch feed controller; and
- 15 i. at least one masterbatch feed controller for each base masterbatch, each masterbatch feed controller configured to adjust the concentration of the base masterbatch in the mixture of raw material fed to the plastic product production machine by optimizing the rate at which the base masterbatch is added to the raw material.

The system is configured to measure the spectra of the in-line part and reference part within a short time interval using the same spectrometer, thereby eliminating the requirement for high accuracy spectrometer
20 calibration and allowing the rates at which the base masterbatches are added to the raw material to be adjusted in real time on the manufacturing floor while the plastic product production machine is being operated to manufacture in-line parts.

In embodiments of the system of the invention the measurement heads
25 comprise light baffles and polarizers to reduce the effects of specular reflections and stray light.

- 7 -

In embodiments of the system of the invention at least one light source is located in each measurement head and the optical network for return light is comprised of optical elements composed of at least one of each of at least one of the following: lenses, mirrors, beam splitters, cosine correctors, and
5 homogenizers.

In embodiments of the system of the invention at least one light source is located in each measurement head and the optical network for return light from each measurement head is comprised of optical fibers and a Nx1 optical fiber combiner is used to combine the separate optical fibers from
10 each measurement head into a single optical fiber that is connected to the input of the spectrometer.

In embodiments of the system of the invention only one measurement head and a mechanism for alternately moving one of the reference part or the in-line part under the beginning of the optical network for returning light to
15 the spectrometer.

Embodiments of the system of the invention comprise a single light source and a network of optical fibers adapted to distribute light from the light source to each of the measurement heads, in these embodiments the network comprises one of:

- 20 a. a 1xN optical fiber splitter which divides light from a single fiber that is optically coupled to the light source to one or more fibers that conduct light from the optical fiber splitter to the measurement heads; and
- b. an apparatus located in front of the light source comprising a motor
25 and a rotatable disk comprising at least one hole or slit the apparatus configured such that when the motor is activated to rotate the disk light is able to enter only one of a plurality of optical fibers that each lead to a measurement head at a time.

- 8 -

Embodiments of the system of the invention comprise a plurality of reference samples located on a mechanism configured to place one of the reference samples at a time opposite a measurement head.

In embodiments of the system of the invention the spectrometer is a Czerny-
5 Turner monochromator comprising a grating to diffract the return light from the measurement heads, a linear sensor array at its output to detect the diffracted light, and a corrector element or elements to compensate for aberrations of the optical elements.

Embodiments of the system of the invention comprise a measurement head
10 for use in reflective measurements from a sample located a distance h from the front surface of a lens having focal length f and both the end facets of illumination and light return (collection) fibers are located near the focal point on the back side of the lens, wherein $h \leq f$.

Embodiments of the system of the invention comprise a measurement head
15 for use in transmissive measurements from a sample whose front side is located a distance h_1 from the front surface of a first lens having focal length f_1 and the end facets of either the illumination or the light return (collection) fibers is located near the focal point on the back side of the first lens, wherein $h_1 \leq f_1/2$ and the back side of the sample is located a distance h_2
20 from the front surface of a second lens having focal length f_2 and the end facets of the other of the illumination or light return (collection) fibers is located near the focal point on the back side of the second lens, wherein $h_2 \leq f_2/2$.

All the above and other characteristics and advantages of the invention will
25 be further understood through the following illustrative and non-limitative description of embodiments thereof, with reference to the appended drawings.

Brief description of drawings

- Fig. 1 schematically shows a gravimetric additive feeder system for an injection molding machine according to the prior art;
- 5 – Fig. 2(a) schematically shows a calculation method of the reference and the part color coordinates from the spectrum data according to an embodiment of the invention;
- 10 – Figs. 2(b) – 2(c) schematically shows a derivation of the optimal error signal for the screw control loop on the chromaticity diagram, based on minimum saturation requirement, corresponding to the minimum consumption of the color masterbatch, lying within MacAdam ellipse of undistinguishable colors, according to an embodiment of the invention;
- 15 – Fig. 2(d) schematically shows an additional algorithm for derivation of the optimal error signal for the screw control loop on the chromaticity diagram, based directly on the minimum consumption of the color masterbatch, lying within MacAdam ellipse of undistinguishable colors, according to an embodiment of the invention;
- 20 – Fig. 3 shows a schematic layout of the comparative spectral measurement based masterbatch feeding screw control system concept according to an embodiment of the invention;
- 25 – Fig. 4(a) schematically shows an external lighting optical fiber based implementation example of the comparative spectral measurement masterbatch feeding screw control system, according to an embodiment of the invention;
- Fig. 4(b) schematically shows an alternative implementation of the comparative spectral measurement masterbatch feeding screw control

- 10 -

system according to an embodiment of the invention, when the reference sample is periodically measured with the same spectrometer as the in-line manufactured parts;

- 5 – Fig. 4(c) schematically shows an external lighting optical fiber based implementation example of the comparative spectral measurement system with multiple measurement heads, according to an embodiment of the invention;
- 10 – Fig. 5 schematically shows a fiber delivered lighting optical fiber based implementation example of the comparative spectral measurement masterbatch feeding screw control system, according to an embodiment of the invention;
- Fig 6 schematically shows the system of the invention according to an embodiment of the invention which is intended for mixing multiple color masterbatches;
- 15 – Figs. 7(a) - 7(b) schematically show an example of the method of the invention according to an embodiment of the invention to control the mixing quantities of the masterbatches;
- Fig. 8 schematically shows a layout of the illumination module of the invention with reduced effect of specular reflections, used for the measurement head of the comparative spectral measurement based masterbatch feeding screw control system;
- 20 – Fig.9 schematically shows a layout of the system of the invention according to an embodiment of the present invention where the reference part is substituted by interchangeable reference samples array with known spectral properties, used for automatic absolute calibration of the spectrometer system;
- 25

- 11 -

- Fig. 10 schematically shows an embodiment of spectrometer 36 that can be used to carry out the invention;
- Figs. 11(a) and 11(b) schematically show in more detail an example of an optical probe assembly comprising two measurement heads such as shown in Fig. 5;
- Figs. 12(a) and 12(b) schematically show in more detail an example of an optical probe assembly comprising multiple measurement heads such as shown in Fig. 4(c);
- Fig. 13 schematically shows an embodiment of a setup for introducing a single light source into a plurality of optical fibers while only one fiber at a time is illuminated;
- Fig. 14(a) schematically shows an embodiment of an optical layout for a measurement head for use in reflective measurements;
- Fig. 14(b) schematically shows an embodiment of an optical layout for a measurement head for use in transmissive measurements; and
- Fig. 14(c) shows an example of the dependence of the color difference between the reference and the sample parts on the distance from the lens of the measurement head to the sample part surface.

Detailed description of the invention

The present invention is a method and system for optimizing the amount of fed color masterbatches in a plastic product production line by in-line measurement of the spectral properties of the product and a reference object, processing of spectral properties of the product and reference object, comparing the processed spectral properties, and controlling feeding screws by using the signals obtained from the. Implementation of the method of the invention by using a spectrometer based system with robust calibration-free

- 12 -

differential measurement of the manufactured part and the reference part is also disclosed.

Fig. 1 schematically shows a prior art gravimetric additive mixing system. The feed screw 11 meters masterbatch or another additive into the main flow of material. The masterbatch is drawn from supply container 12 into hopper 13 where it is weighed with a loss-in-weight balance and distributed in the flow of base material out of hopper 14. Metering of the masterbatch is synchronized with the molding machine's feed screw 15.

Since it is impossible in most of the cases to weigh a discrete portion of the additive that is fed during a cycle time due to its tiny weight and the very noisy and shaky environment of the production area, the system uses a closed loop feedback operation to control the weight of the portion by weighing a number of dispensed portions using loss-in-weight of the hopper, dividing the weight by the number of portions and, controlling the speed of the screw feeder motor to dispense in a given time portions each with a predetermined weight for a given interval of time.

Fig. 2(a) schematically shows a method for optimal control of the feeding screw speed according to an embodiment of the present invention. In the first step 201 an optical spectrum is measured for a reference material part and for an in-line part. Fig. 2(b) shows the optical spectrum of the reference part 210 and of the in-line part 220 and the color response functions. In the second step 202 the color coordinates of the in-line part (x, y, Y) and of the reference material (x0, y0, Y0) in xyY color space are determined as follows:

25

$$X = \int_{380}^{780} I(\lambda) \bar{x}(\lambda) d\lambda$$

$$Y = \int_{380}^{780} I(\lambda) \bar{y}(\lambda) d\lambda$$

- 13 -

$$Z = \int_{380}^{780} I(\lambda) \bar{z}(\lambda) d\lambda$$

where $I(\lambda)$ is the spectral power density of the measured sample. The obtained coordinates are translated into the CIE xyY color space which can be seen in Fig. 2(c), by well-known linear transformation. Where $\bar{x}, \bar{y}, \bar{z}$, are standard observer color matching functions and the transformation from XYZ to xyY is:

$$x = \frac{X}{X + Y + Z}$$

$$y = \frac{Y}{X + Y + Z}$$

$$Y = Y$$

Fig. 2(c) shows the chromaticity diagram. The "star" point 228 is the color coordinates of the masterbatch material. Point 225 and point 226 are the color coordinates received in step 202 of the in-line part and the reference part respectively. Star 223 in the center of the chromaticity diagram is the white color, which is the lowest saturation value point. As a first approximation, varying the masterbatch concentration will move the color coordinate of the in-line part along the dashed line. The maximum saturation value colors are located on the boundaries. To achieve higher saturation value, more color masterbatch should be added to the base material.

A human eye cannot differentiate colors within a certain area 224, called the MacAdam ellipse, surrounding a point on the chromaticity diagram. The size of the ellipse varies with the location of the point on the chromaticity diagram. Boundaries of the undistinguishable colors region are defined by the CIEDE2000 standard.

- 14 -

In step 203 a set point 227 is determined. The set point 227 is the lowest saturation point on the undistinguishable color boundary. i.e. the MacAdam ellipse, around the reference material sample color 226 (x0,y0,Y0). The saturation point corresponds to the lowest concentration of masterbatch
5 required to make the color of the in-line part indistinguishable to the human eye from the color of the reference part. The lowest saturation point can be found by maximizing the distance from the boundaries of the chromaticity diagram or by minimizing the distance from the color coordinates of the in-line part to the white center point 223 or by mathematical definition of
10 saturation (S) value by transformation from xyY color space into the HSV color space.

In step 204, using the CIEDE2000 formula the distance ΔE between the in-line part color 225 and the above defined set point 227 is determined. In
15 step 205 the signal used for controlling the feeding screw rotation speed is calculated. This signal is defined as:

$$Err = \Delta E * f(S_0 - S),$$

20 where S_0 and S are saturation values of the reference sample and the in-line part colors respectively, and $f(S_0 - S) = f(x)$ is a weighting function, which, for example, can take the values: $f(x) = -1$, if $x < -1$; $f(x) = 1$, if $x > 1$ and $f(x) = x$ otherwise.

25 In the last step 206, the error signal is used to control the feeding screw rotation speed.

Fig. 2(d) provides a refined method for determination of the optimal feeding screw error input, based on the fact that the color resulting from various
30 pigment (masterbatch) concentrations does not follow a straight line but

- 15 -

follows a curved path 238 as shown in Fig. 2(c). The more exact behavior is described by a well know Kubelka Munk model (see for example Georg A. Klein, "Industrial Color Physics", Springer 2010, pg. 326 - 337). In this case the initial error is evaluated following the straight line between the color coordinates of the in-line part 225 and those of the reference part 226
5 resulting in a correction ΔE_1 in the same manner as described in the Fig. 2(c). The color of the in-line part resulting from the masterbatch concentration adjusted using ΔE_1 will not lie on the MacAdam ellipse 224 but will have coordinates 229. From this point, the error is evaluated again
10 using a straight line between points 229 and 224 and the process is iterated, until the in-line part color coordinate crosses the MacAdam ellipse 224 (or its approximation by some constant ΔE value, typically about 2.5) from the low saturation side. The actual end result of this method is that the resulting in-line part color coordinate is 210 instead of 227 as is expected
15 from the simpler model of Fig. 2(c).

Fig. 3 shows a system according to an embodiment of the present invention. A schematic layout of the comparative spectral measurement based masterbatch feeding screw control system is shown. Precision color
20 measurement based on optical spectrum is an extremely challenging process, since fractions of percents of calibration accuracy are required. Due to this fact, spectrometers are rarely used on manufacturing floors, but rather in analytic and quality control laboratories, since maintaining those high accuracy calibrations is rather impractical on manufacturing floors.
25 The method of the present invention which is described above in Fig. 2 is implemented by measuring the reference sample and the in-line part spectrum simultaneously using the same spectrometer. In this case deviations from nominal spectrometer calibration are the same for both the measurement and the reference; that is no high accuracy spectrometer
30 calibration is required. Due to a control feedback loop used for the feeding

- 16 -

screw control, color difference error inaccuracy resulting from the spectrometer calibration deviation turns out to be insignificant.

The schematic layout of the differential spectrometer, which measures the in-line part and the reference part while comparing their color coordinates, is shown in Fig. 3). The optical signals reflected back from the measurement heads for the reference material part 31 and the in-line sample 32 are combined by 50%/50% beamsplitter 35 and sent to a spectrometer 36. Each measurement head utilizes a white light source 33 (implemented by LED, halogen lamp, fluorescent lamp, incandescent source, supercontinuum laser or any other wide spectrum light source). A cosine corrector or homogenizer 34 is used on the entrance into the light collection optics in order to minimize the spectrum dependence on the measurement geometry. The light sources 33 for the reference and in-line measurement heads are operated intermittently while enabling interlaced the measurement of the reference sample and the in-line part spectra. Both spectra are analyzed in the spectrum processing and illumination control unit 37, according to the method of the present invention as described above and the resulting value of the "error signal" 39 is sent to the feeding screw rotation velocity controller 38.

Fig. 4(a) schematically shows an example of another implementation of the system of the present invention according to an embodiment of the invention, wherein the light is collected from both measurement heads for both samples 31, 32 using optical fibers 41 and 42, combined by 2x1 fiber combiner 43 and conducted through optical fiber 44 to the spectrometer 36.

Fig. 4(b) schematically shows an alternative implementation of the system using a single spectral measurement head for both the reference part 31 and the in-line part 32. A mechanism, symbolically shown by double headed

- 17 -

arrow 45, periodically moves the in-line part 32 to the side and moves the reference part 31 under the measurement head to measure its color spectrum. The parameters of the color of the reference part are stored in the memory and used for calculating the feeding screw control error in the manner as disclosed in Fig. 2.

Fig. 4(c) schematically shows an example of an implementation of the system according to an embodiment of the invention. According to this embodiment of the invention the system utilizes multiple (more than 2) measurement heads for measuring the in-line part samples $32_1, 32_2 \dots 32_{n-1}$ at different locations in order to evaluate the color homogeneity for quality assurance. In this embodiment the feeding screw control 38 uses the average signal of all measurement heads, their scatter and their color deviation from the reference part 31. Nx1 fiber combiner 43 is utilized to combine the multiple n-1 measurement heads into a single fiber attached to a spectrometer 36.

Fig. 5 schematically shows an implementation of a system according to another embodiment of the invention, wherein a single light source 33 used. The light from source 33 passes through fiber branch 57 until it is split into two equal parts by 2x2 optical fiber splitter/combiner 55 from which light is transmitted to both measurement heads through the fiber branches 58 and 59. The return signal from both measurement heads are transmitted through the same fiber branches 58 and 59 and are combined by the same 2x2 splitter/combiner 55 and sent to the spectrometer via the fiber branch 56. Alternatively, the light source 33 may comprise a plurality of separate light sources with the same or different properties like spectral intensity distribution and power, all combined with a beam combiner into a single fiber 57. This way a specific required spectral distribution may be achieved, for example a more balanced intensity distribution spectrum may be

- 18 -

achieved by combining a halogen lamp, lacking intensity at short wavelengths, with a blue or white light emitting diode.

In the embodiment shown in Fig. 5, separate measurements of the reference
5 and of the in-line parts is achieved by the following method. The light source
operates continuously. The reference sample 31 is always in place and its
spectrum is measured by the spectrometer 36 when there is no in-line part
near the measurement head. Once a discrete signal 50 from the in-line
10 parts measurement head indicates that an in-line part moving on the
production line (symbolically shown by arrow 51) is in place under the
measurement head, a combined signal from the in-line part and the
reference part is measured. The spectrum of the in-line part is obtained by
subtracting the spectrum of the reference part from the combined signal.
The inherent advantage of this embodiment of the method of the invention
15 compared to separate intermittent illumination is that precisely the same
illumination is used for measuring both the reference and the in-line parts,
improving the result accuracy. However, this embodiment causes a 50% loss
for the spectrum signal compared to the implementation shown in Fig. 4.

20 Fig. 6 schematically shows the layout of the system of the present invention
which is intended for mixing multiple color masterbatches (called the "base"
masterbatches) in order to obtain a mixture that results in the color of the
in-line part being coincident with that of the reference part after the
masterbatches are added into the processing machine. The system
25 comprises a separate feeding module $61_1, 61_2, \dots, 61_n$ that can be either
volumetric, gravimetric or any other quantification method based (the
gravimetric example is shown in Fig. 1) for each of the base masterbatches.
The feeding mechanisms of those modules are controlled by a differential
spectrometer system 62 that processes signal from measurement heads 63
30 and 64 for the reference part and the in-line parts respectively as disclosed

- 19 -

with respect to the previous Figs 3-5, wherein each module is controlled by a different controller 38₁, 38₂,...38_n using the method that is described herein below in Figs. 7(a)-(b).

5 Figs. 7(a)-(b) show an example of a method according to an embodiment of the invention, which is used to control the mixing quantities of the masterbatches. The goal of the method is to define the set point 227, which is located within the MacAdam ellipse 224 of undistinguishable colors surrounding the coordinates 226 of the reference part, at the lowest color
10 saturation point. This ensures that the in-line part color is indistinguishable from the reference sample and the manufacturing process consumes the least amount of the masterbatch material. The output of the algorithm is the amount of increase/decrease of the percent of each particular base masterbatch in the mixture of masterbatches.

15

First, as can be seen in Fig. 7(a) the MacAdam ellipse 224 and the relative error ΔE 72 are calculated in the same way described above in Fig. 2. The stars 73, 74 and 75 are the color coordinates of each different base masterbatch respectively. Open circle 225 and filled circle 226 are the color
20 coordinates of the in-line and reference parts respectively. In Fig 7(b) the ΔE vector 72 is projected on the axes defined by vectors connected the base masterbatches. The projections are used as the error corrections 39₁,39₂...39_n of the loops controlling the feeding screw (using a standard PI or PID control loop, as commonly done in all industrial control systems),
25 intended to minimize the differences between the colors of the reference part and the in-line parts.

Practically, three base masterbatches are enough to span most of the colors lying within the triangle connecting them. Alternatively, more base
30 masterbatches can be used so that more than one possibility exists to

- 20 -

determine the component of the error vector ΔE for each of the base masterbatches. In this case a predefined merit function (for example cost or amount of added material) is used to select the optimal combination of masterbatches to minimize the error between the reference sample and the
5 manufactured parts.

Fig. 8 shows the schematic layout of an embodiment of an illumination and light collection module, i.e. a measurement head. Typically, the lighting conditions affect greatly the resulting color coordinates of the measured
10 sample. To minimize the influence of random light on the measurements, in embodiments of the invention light baffles and optical elements are utilized to accurately control the lighting conditions in order to minimize the effect of specular reflections by accurate optical design of the illumination and light collection means.

15

In the embodiment shown in Fig. 8 light from the illumination source 33 passes through a polarizer 81. The light reflected from the part 32 is collected by the optical fiber 82. Another polarizer 83 with orientation perpendicular to that of polarizer 81 is introduced in front of the fiber 82.
20 The polarizer 83 blocks most of the specular reflections and allows only diffusely scattered light to enter the collection fiber since diffuse reflections are mostly un-polarized, while specular reflection mostly maintains the incident light polarization. In order to further eliminate stray light, a baffle 84 is introduced around the fiber in order to block the stray light 85.

25

In other embodiments specular reflected light can be eliminated by other combinations of polarizers such as a half wave plate with linear polarizer, which is known to prevent light from being reflected backwards and circular polarizers.

30

- 21 -

Fig. 9 schematically shows a layout for an embodiment of a method for automatic absolute calibration of the differential spectrometer. Usually, in cases where there is no reference sample available, and the part color is defined by color coordinates (for example xyY, Lab, Luv, HSV,sRGB, XYZ or
5 others) there is a need to define the reference point 226 in Fig. 2(c) numerically. In order to do so, the measurement of the color of the manufactured parts should be calibrated to absolute color coordinates. However, in the system of the present invention, the absolute color coordinates are parameters that are not required while using differential
10 measurement as disclosed herein. The present invention discloses a method for automatic on-line calibration of the system without operator intervention eliminating the need for accurate periodic calibrations, which require highly qualified personnel and are sensitive to changes in environmental conditions, vary with time, etc.

15

As can be seen in Fig. 9, a single reference sample is replaced by an array 90, which contains a plurality of reference samples 91 having distinct known spectral properties. This array 90 of reference samples 91 is attached to actuation means 92 capable of moving reference samples 91 so that the
20 spectrum of only one of them is measured at a time. The reference samples can either reflect the light from source 33 as shown in Fig. 9 or transmit the incident light, in which case the reference sample should be located between the illumination means 33 and the measurement fiber 42.

25 The calibration procedure is activated periodically, by measuring each of the reference samples. The present invention system's spectral response calculation is performed from the comparison of the measured spectra with the known one for each sample. One example of such a calculation is to divide the obtained spectrum by the known one for each sample and
30 averaging the results for a plurality of reference samples. Other more

- 22 -

sophisticated and accurate methods for calculation of the system response from the plurality of known reference samples measurements are known.

Fig. 10 schematically shows an embodiment of spectrometer 36 that can be used to carry out the invention. The optical layout of this embodiment of spectrometer 36 is based on a well-known Czerny–Turner monochromator with the addition of a correction element before the linear sensor array that is introduced in order to compensate for aberrations of the optical elements. Use of this correction element enables low f-number designs within compact physical dimensions.

In Fig. 10, the collected light is transmitted to the spectrometer 36 by optical fiber 102. The input fiber light is limited in the horizontal direction by a vertical slit 104 ranging from 10-500 microns in width, depending on the required resolution. The light passing through slit 104 is reflected from a first concave mirror 106 located at a distance equal to its focal length from slit 104 in order to collimate the light from the fiber 102. The collimated beam is diffracted by a diffraction grating 108 having, for example, 300 grooves/mm and focused by a second concave mirror 112 onto a sensor array 116 after passing through a corrector element 114. In the simplest case the corrector element 114 is a cylindrical lens that compensates for the strong astigmatism from the angled mirrors. This arrangement allows optical resolution below 10 nm with 1 mm input optical fiber with a numerical aperture 0.5. In a more complex setting allowing higher resolution, more complex correction elements might be used, e.g. phase masks, diffractive elements, or multiple optical elements.

Figs. 11(a) and 11(b) schematically show in more detail an example of an optical probe assembly comprising two measurement heads such as shown in Fig. 5. Fig. 11(a) is an overall view of the assembly and Fig. 11(b) is a magnified view of section A in Fig. 11(a) showing the internal features of the

- 23 -

branches. Light from an illumination source is introduced into two optical fibers 57a and 57b within the illumination branch 57. After passing through a 2x2 optical fiber splitter/combiner 55 each fiber 57a and 57b is further guided by a separate branch 58 and 59 to measurement heads 110 and 111 for the in-line part and reference parts respectively. Fibers 112a and 112b within branches 58 and 59 return light collected by measuring heads 110 and 111 respectively and either pass through optical fiber splitter/combiner 55 to separate signal branches 56a and 56b or are optionally combined by the optical fiber splitter/combiner 55 into a single signal branch 56 as in Fig. 5.

Figs. 12(a) and 12(b) schematically show in more detail an example of an optical probe assembly comprising multiple measurement heads such as shown in Fig. 4(c). Fig. 12(a) is a schematic view of the various branches bringing light to and collected light from the measurement heads 110a-110n-1 and 111. Fig. 12(b) schematically shows the routing of the illumination fibers 115 and the collection fibers 116 within the optical probe assembly wherein the collection fibers 116 are combined into a single fiber using a nx1 optical fiber combiner 117.

Fig. 13 schematically shows an embodiment of a setup for introducing a single light source into a plurality of optical fibers while only one fiber at a time is illuminated. The light source 130, which is optionally followed by an optical system to create a uniform light distribution at the plane 131 of the facets 132 of the optical fibers, is filtered by optical filter 133 to remove all unnecessary radiation in order to decrease the heat load on fiber facets. For color measurement applications, the filter reflects infrared and transmits visible light. An opaque disk 134 with a plurality of holes is attached to a servo motor 135. The locations of the holes are determined in such a way that as the disk rotates, a different fiber fact is illuminated, while light to all the others is blocked. Alternatively, a steadily rotating DC motor can be

- 24 -

used with a disk having tangential slits rather than holes, sequentially exposing each fiber for a predetermined period of time.

Fig. 14(a) schematically shows an embodiment of an optical layout for a measurement head for use in reflective measurements. In this embodiment the measurement head 140 is located at a distance h from the front surface of sample 141. This design addresses two issues with remote color measurement – dependence on the distance to the sample and dependence on the surface angle due to a varying amount of specular reflections entering the collection system. The optical design allows minimization of both effects. Both illumination fibers 142 and light collection fibers 143 are located near the focal point of the aspheric or spherical lens 144. Using a 0.25 – 3 mm diameter optical fiber for illumination and an aberration minimized lens, the light distribution on the sample surface is such, that the reflected light collected by the collection fiber is independent of the distance to the sample surface within at least half of the lens focal length. This effect is shown in the figure 14(c), which is a graph showing the dependence of the color difference between the reference and the sample parts on the distance from the lens of the measurement head to the sample part surface. The surface angle dependence effect is minimized by introducing two crossed polarizers (i.e. for example two linear polarizers wherein one is vertically oriented on the other is horizontally oriented as indicated by arrows in the section view of Fig. 14(a)). The polarizers block both light scattered from the lens surface and the specular reflection from the sample surface.

Fig. 14(b) schematically shows an embodiment of an optical layout for a measurement head for use in transmission color measurement, wherein the illumination and collection fibers are located at opposite sides of the sample.

Although embodiments of the invention have been described by way of illustration, it will be understood that the invention may be carried out with

- 25 -

many variations, modifications, and adaptations, without exceeding the scope of the claims.

Claims

1. A method for optimizing a match between the color of an in-line part manufactured by a plastic product production machine and the color of a reference part by adjusting the concentration of masterbatch in the mixture of raw material fed to the plastic product production machine,
5 the method comprising:

- a. measuring the spectrum of the in-line part with a spectrometer;
- b. measuring the spectrum of the reference part with a spectrometer;
- c. determining the color coordinates of the in-line part and the reference
10 part from the spectra measured in steps a and b;

- d. determining the color coordinates of a set point, which corresponds to the lowest concentration of masterbatch required to make the color of the in-line part indistinguishable to the human eye from the color of the reference part;

- 15 e. determining the distance ΔE between the color coordinates of the in-line part and the color coordinates of a set point determined in step d;

- f. determining a signal for controlling the feed speed of the mechanism that adds masterbatch to the mixture of raw material fed to the plastic product production machine; and

- 20 g. controlling the feed speed of the mechanism that adds masterbatch to the mixture of raw material fed to the plastic product production machine by means of the signal determined in step f;

wherein, steps a and b are carried out within a short time interval using the same spectrometer, thereby eliminating the requirement for high
25 accuracy spectrometer calibration and allowing steps a to g of the method to be carried out in real time on a manufacturing floor while the plastic product production machine is being operated to manufacture in-line parts.

- 27 -

2. The method of claim 1, wherein the set point is the lowest saturation point on the MacAdam ellipse around the reference material sample color.

5 3. The method of claim 2, wherein set point can be found in one of the following ways:

a. by maximizing the distance from the boundaries of the chromaticity diagram;

10 b. by minimizing the distance from the color coordinates of the in-line part to the white center point 223; and

c. by mathematical definition of saturation (S) value by transformation from xyY color space into the HSV color space.

15 4. The method of claim 1, wherein the set point is determined by means of an iterative process.

5. The method of claim 1, wherein the distance $\Delta E'$ between the in-line color part and the set point on the chromaticity diagram is determined using the CIEDE2000 formula.

20

6. The method of claim 1, wherein the signal for controlling the feed speed of the mechanism that adds masterbatch to the mixture of raw material fed to the plastic product production machine is defined as

$$Err = \Delta E' * f(S_0 - S),$$

25 where S_0 and S are saturation values of the reference sample and the in-line part colors respectively, and $f(S_0 - S) = f(x)$ is a weighting function.

7. The method of claim 1, wherein the color of the in-line part is determined by the combination of three base masterbatches and the signals for
30 controlling the feed speed of the mechanism that adds masterbatch to

- 28 -

the mixture of raw material fed to the plastic product production machine are determined by projecting the ΔE vector on the axes defined by vectors connecting the locations of the base masterbatches on the chromaticity diagram.

5

8. A system for controlling the concentration of at least one base masterbatch in the mixture of raw material fed to a plastic product production machine in order to optimize the match of the color of an in-line part manufactured by the plastic product production machine to the color of a reference part, the system comprising:

10

a. at least one white light source;

b. at least one measurement head configured for measuring the spectrum an in-line part;

15

c. at least one measurement head configured for measuring the spectrum a reference part;

d. a spectrometer;

e. a network adapted to provide illumination light from the at least one light source to each of the measurement heads;

20

f. an optical network to guide return light that is either reflected from the surface of or transmitted through the in-line and reference parts from each of the measurement heads to the spectrometer;

g. a spectrum processing and control unit configured to receive electric signals representative of the spectra of the in-line and reference parts from the spectrometer, to process the signals and to determine error signals that are sent to at least one feed controller;

25

h. at least one feed controller for each base masterbatch, each feed controller configured to receive an error signal from the spectrum processing and control unit and to send it to a masterbatch feed controller; and

- 29 -

i. at least one masterbatch feed controller for each base masterbatch, each masterbatch feed controller configured to adjust the concentration of the base masterbatch in the mixture of raw material fed to the plastic product production machine by optimizing the rate at which the base masterbatch is added to the raw material;

wherein the system is configured to measure the spectra of the in-line part and reference part within a short time interval using the same spectrometer, thereby eliminating the requirement for high accuracy spectrometer calibration and allowing the rates at which the base masterbatches are added to the raw material to be adjusted in real time on the manufacturing floor while the plastic product production machine is being operated to manufacture in-line parts.

9. The system of claim 8, wherein the measurement heads comprise light baffles and polarizers to reduce the effects of specular reflections and stray light.

10. The system of claim 8, wherein at least one light source is located in each measurement head and the optical network for return light is comprised of optical elements composed of at least one of each of at least one of the following: lenses, mirrors, beam splitters, cosine correctors, and homogenizers.

11. The system of claim 8, wherein at least one light source is located in each measurement head and the optical network for return light from each measurement head is comprised of optical fibers and a Nx1 optical fiber combiner is used to combine the separate optical fibers from each measurement head into a single optical fiber that is connected to the input of the spectrometer.

- 30 -

12. The system of claim 8, comprising only one measurement head and a mechanism for alternately moving one of the reference part or the in-line part under the beginning of the optical network for returning light to the spectrometer.

5

13. The system of claim 8, comprising a single light source and a network of optical fibers adapted to distribute light from the light source to each of the measurement heads, the network comprising one of:

a. a 1xN optical fiber splitter which divides light from a single fiber that is optically coupled to the light source to one or more fibers that conduct light from the optical fiber splitter to the measurement heads; and

b. an apparatus located in front of the light source comprising a motor and a rotatable disk comprising at least one hole or slit the apparatus configured such that when the motor is activated to rotate the disk light is able to enter only one of a plurality of optical fibers that each lead to a measurement head at a time.

14. The system of claim 8, comprising a plurality of reference samples located on a mechanism configured to place one of the reference samples at a time opposite a measurement head.

15. The system of claim 8, wherein the spectrometer is a Czerny-Turner monochromator comprising a grating to diffract the return light from the measurement heads, a linear sensor array at its output to detect the diffracted light, and a corrector element or elements to compensate for aberrations of the optical elements.

16. The system of claim 8, comprising a measurement head for use in reflective measurements from a sample located a distance h from the

30

- 31 -

front surface of a lens having focal length f and both the end facets of illumination and light return (collection) fibers are located near the focal point on the back side of the lens, wherein $h \leq f$.

- 5 17. The system of claim 8, comprising a measurement head for use in transmissive measurements from a sample whose front side is located a distance h_1 from the front surface of a first lens having focal length f_1 and the end facets of either the illumination or the light return (collection) fibers is located near the focal point on the back side of the
- 10 first lens, wherein $h_1 \leq f_1/2$ and the back side of the sample is located a distance h_2 from the front surface of a second lens having focal length f_2 and the end facets of the other of the illumination or light return (collection) fibers is located near the focal point on the back side of the second lens, wherein $h_2 \leq f_2/2$.

15

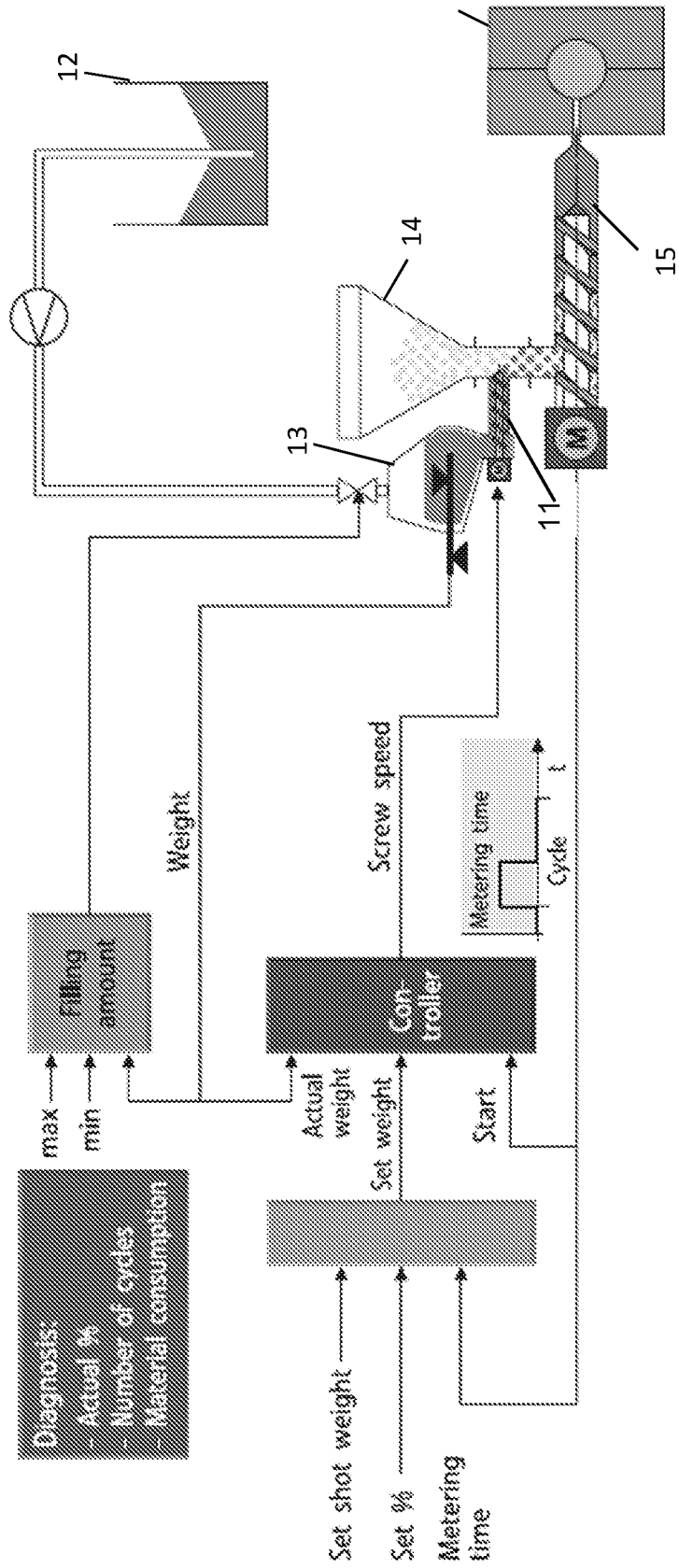

Fig. 1
Prior Art

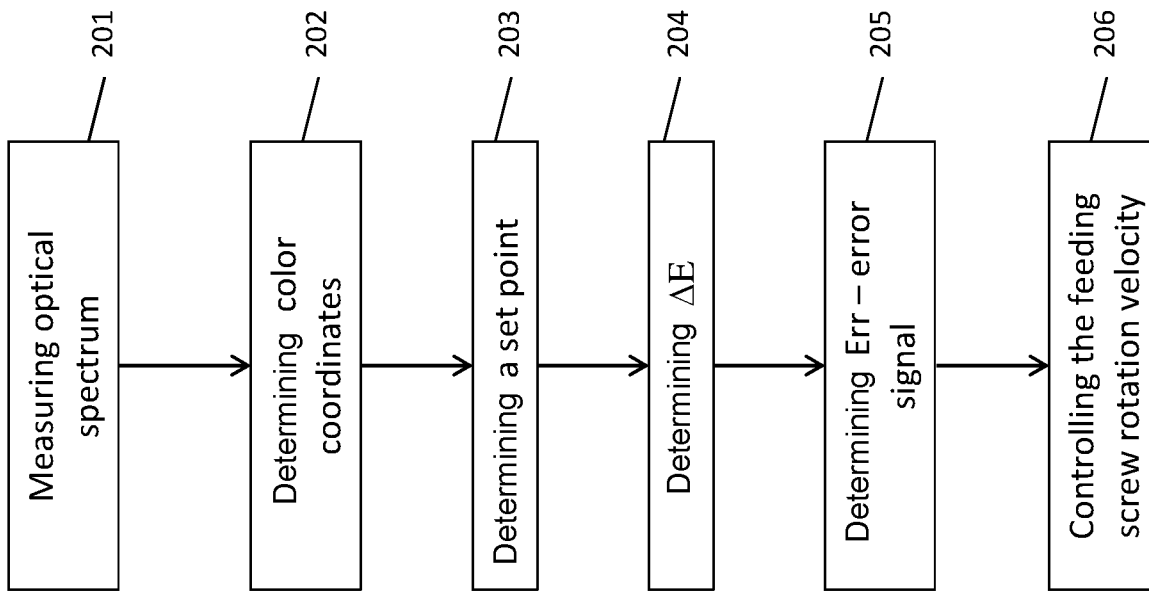

Fig. 2(a)

3/20

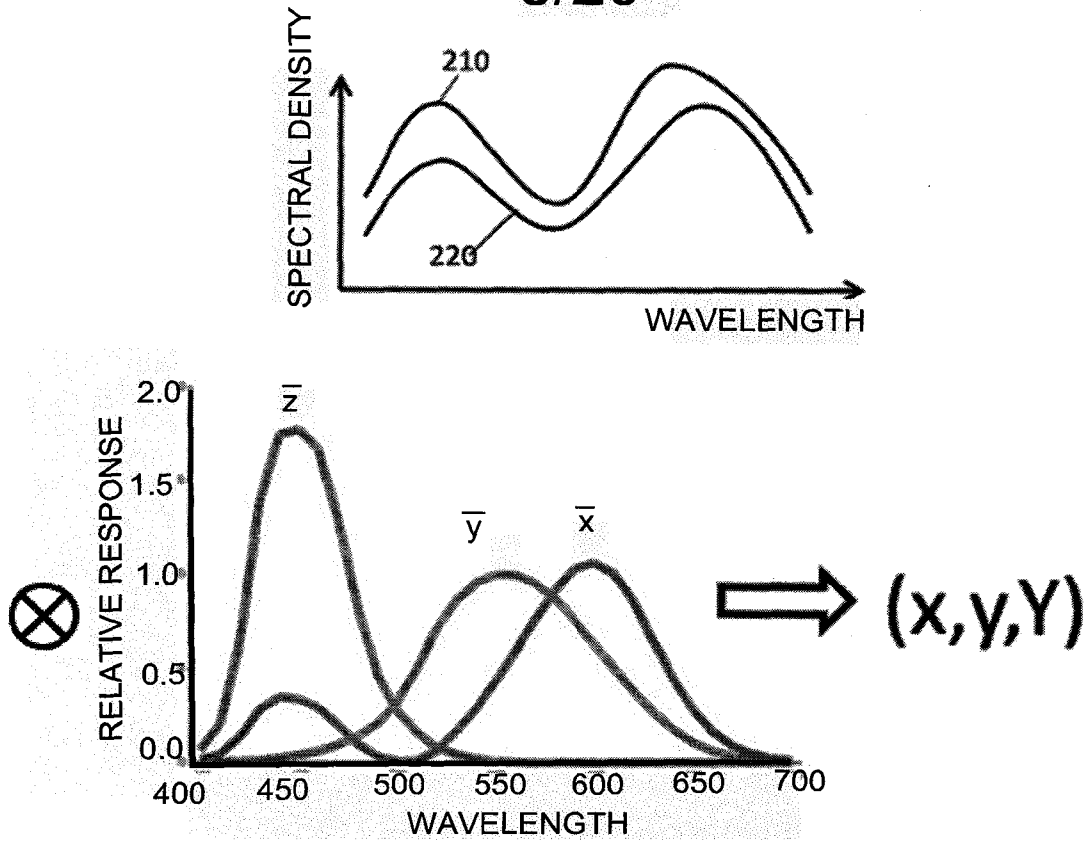

Fig. 2(b)

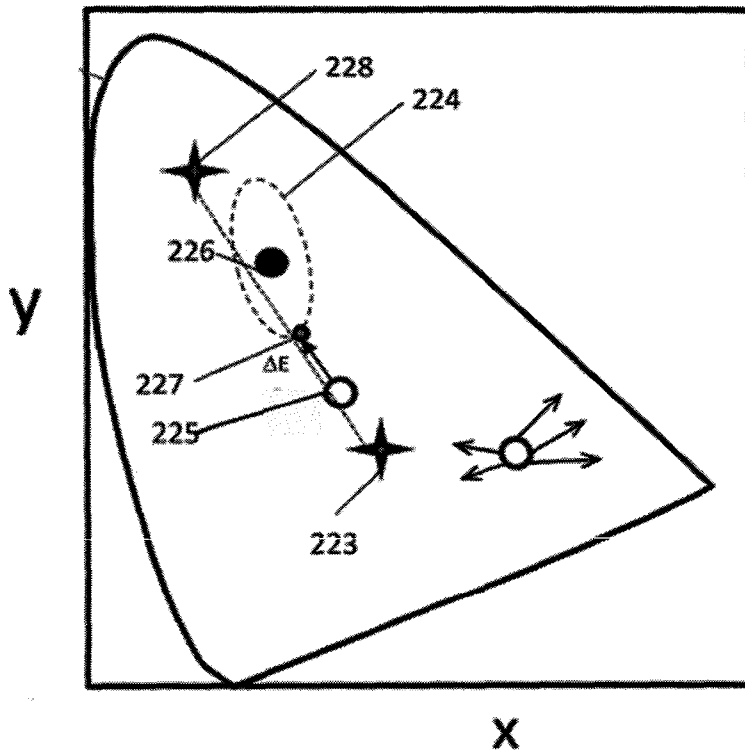
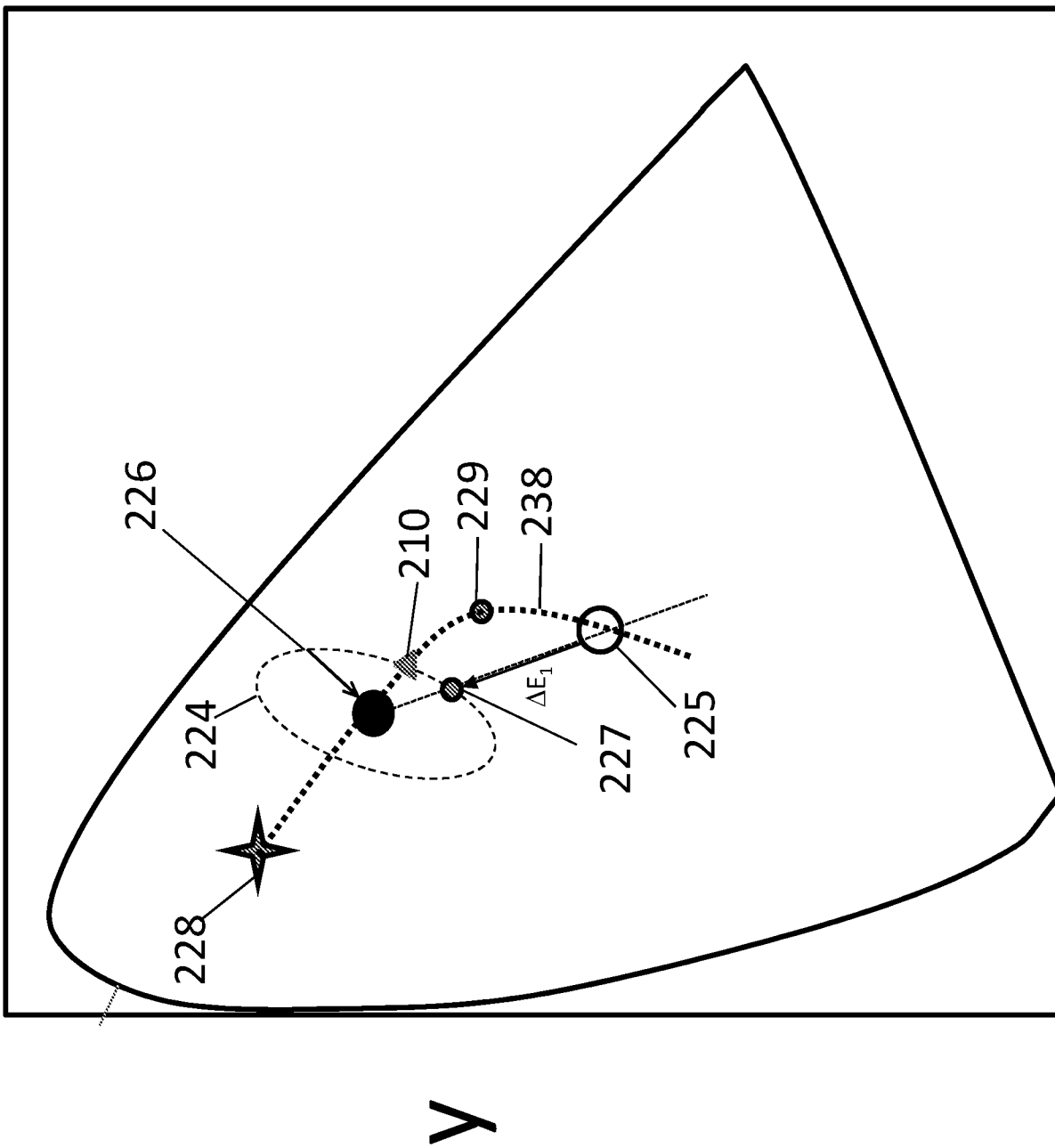

Fig. 2(c)

4/20



X
Fig. 2 (d)

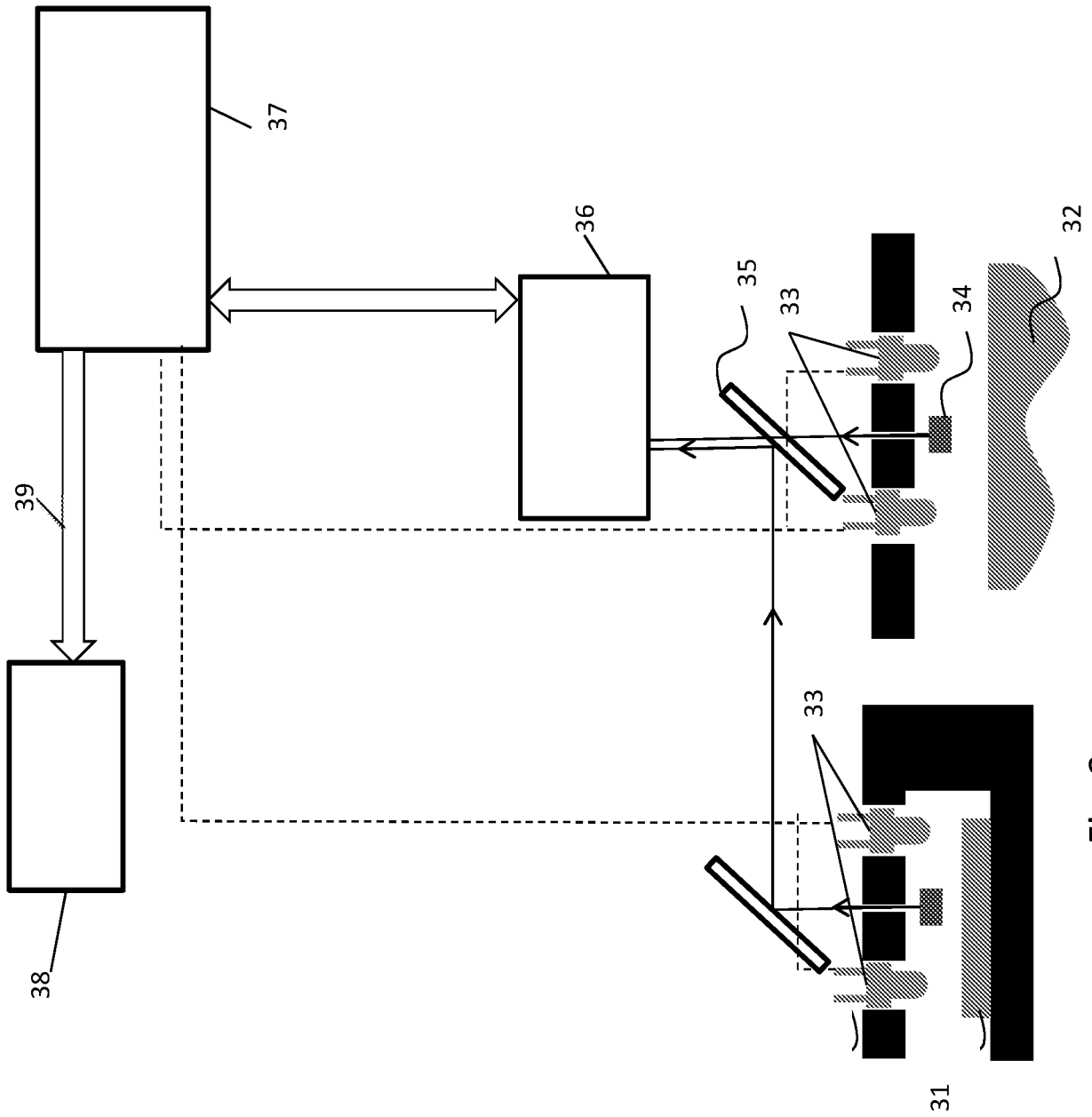

Fig. 3

6/20

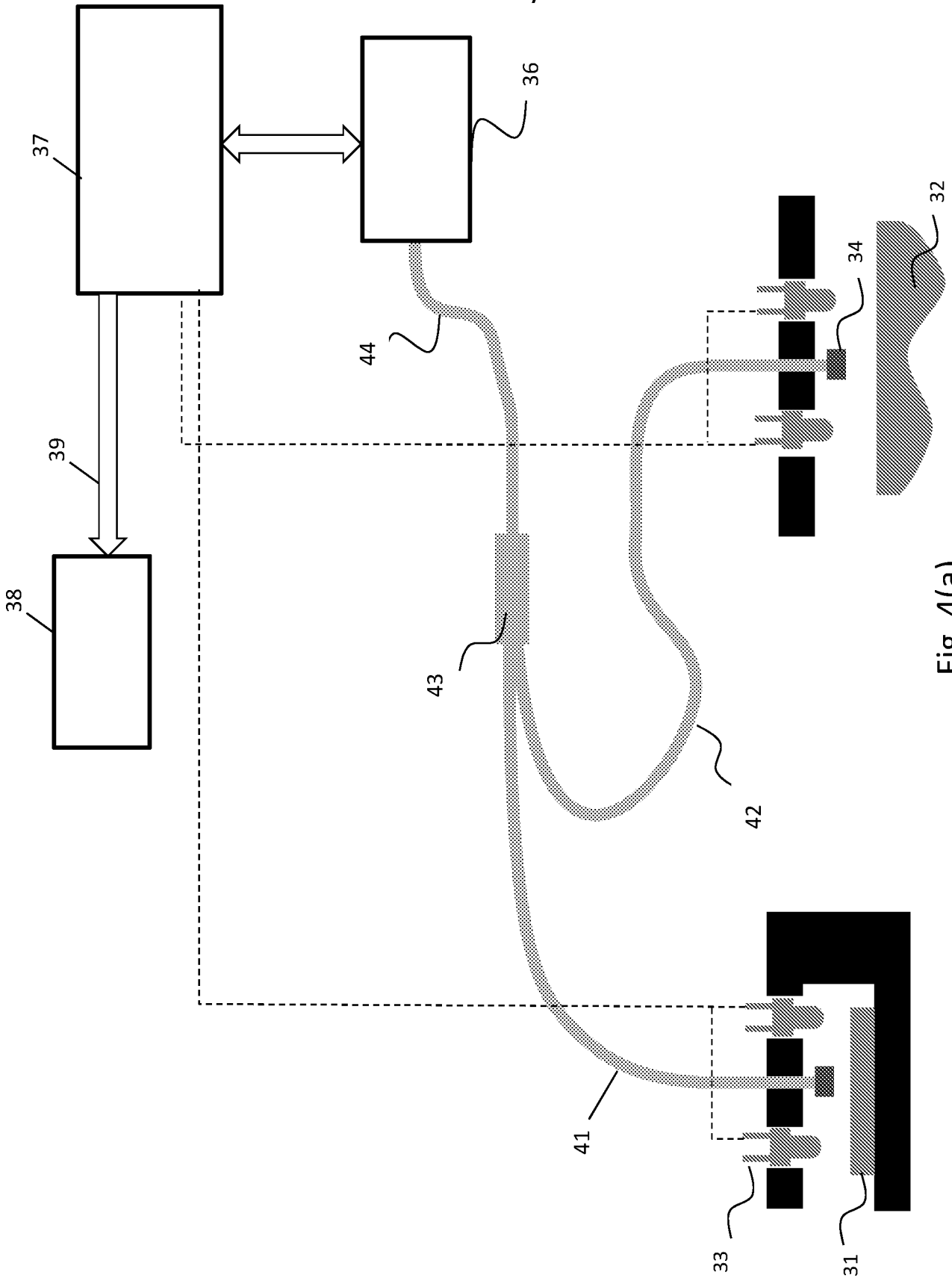

Fig. 4(a)

7/20

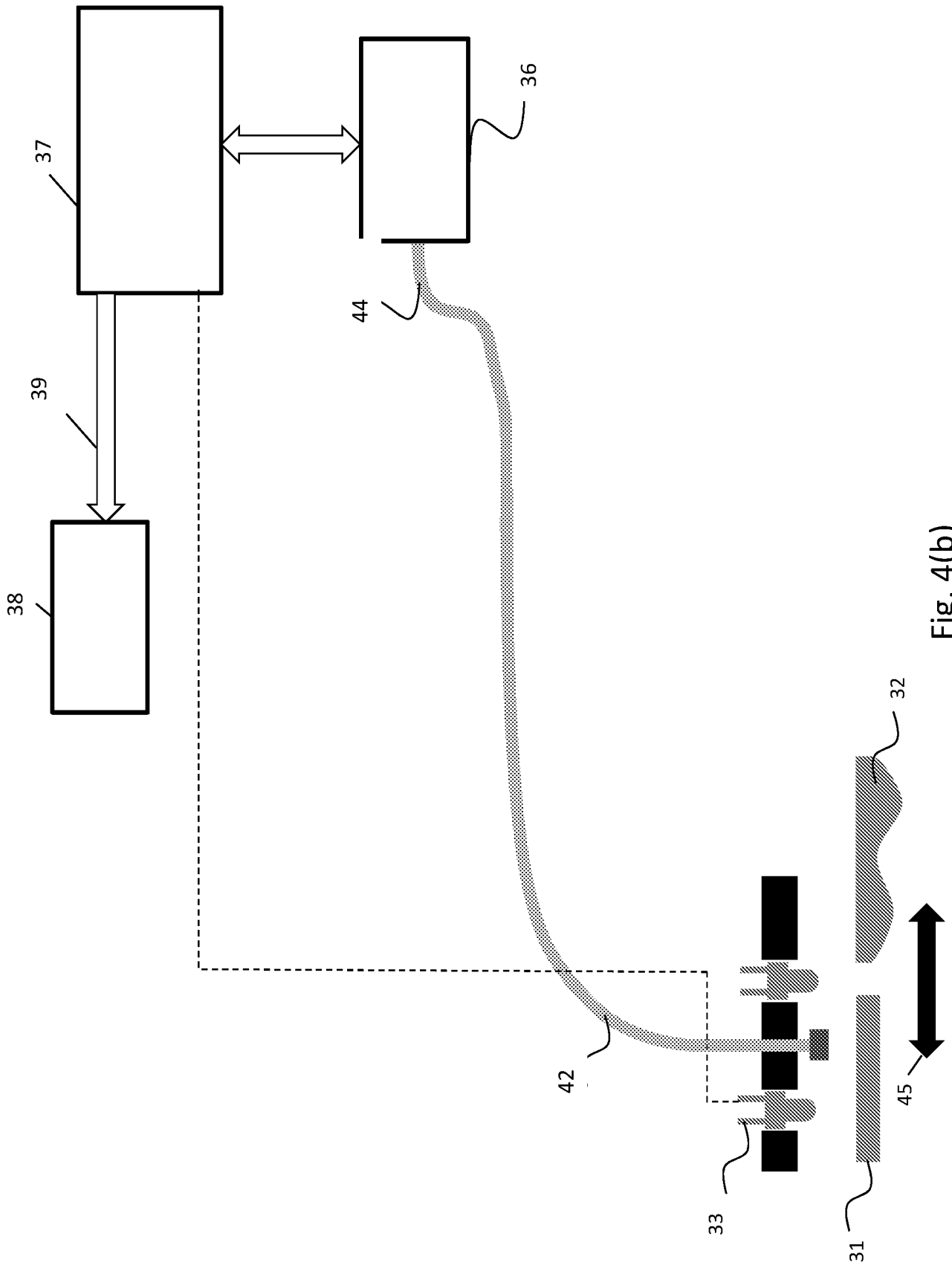
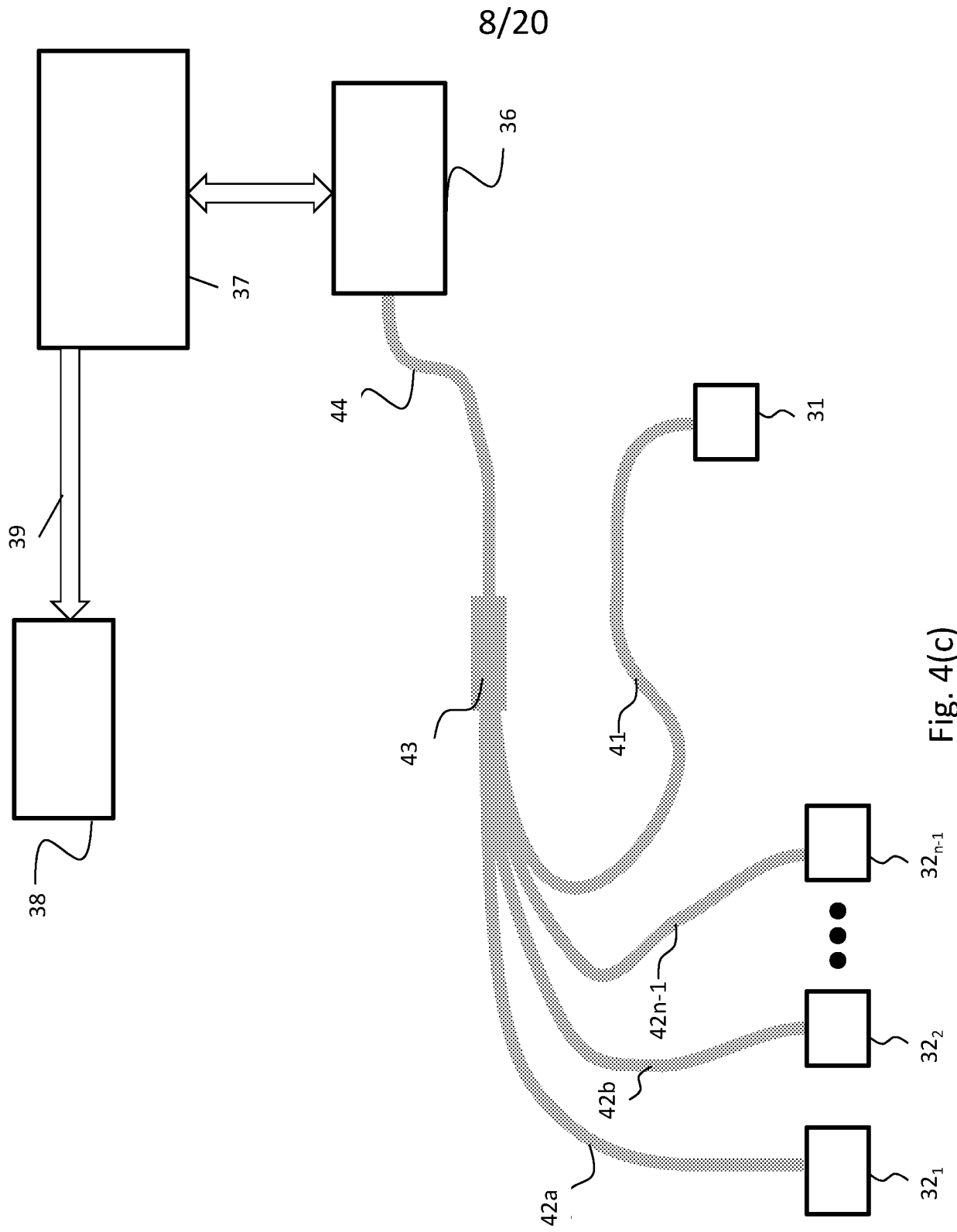

Fig. 4(b)



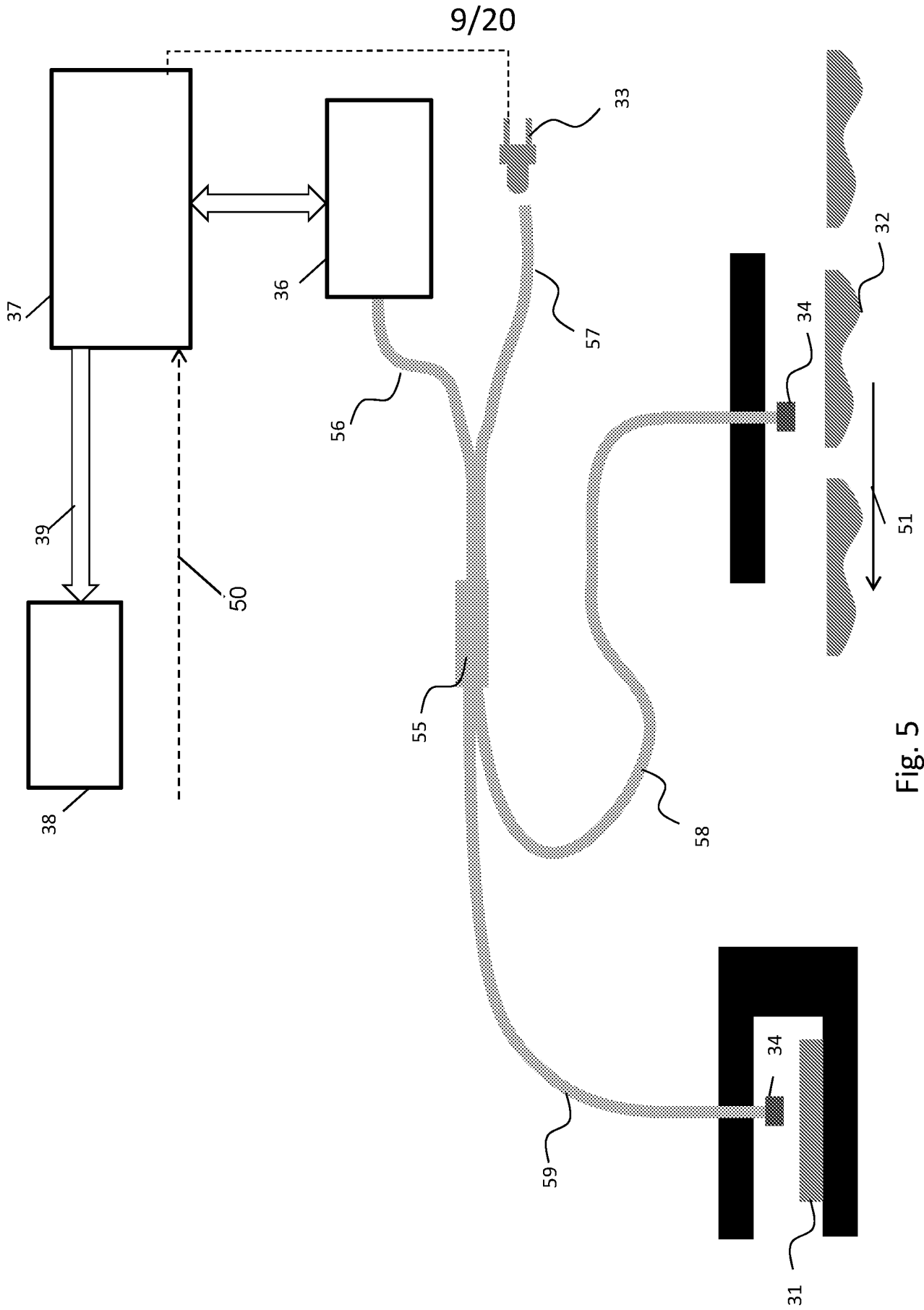

Fig. 5

10/20

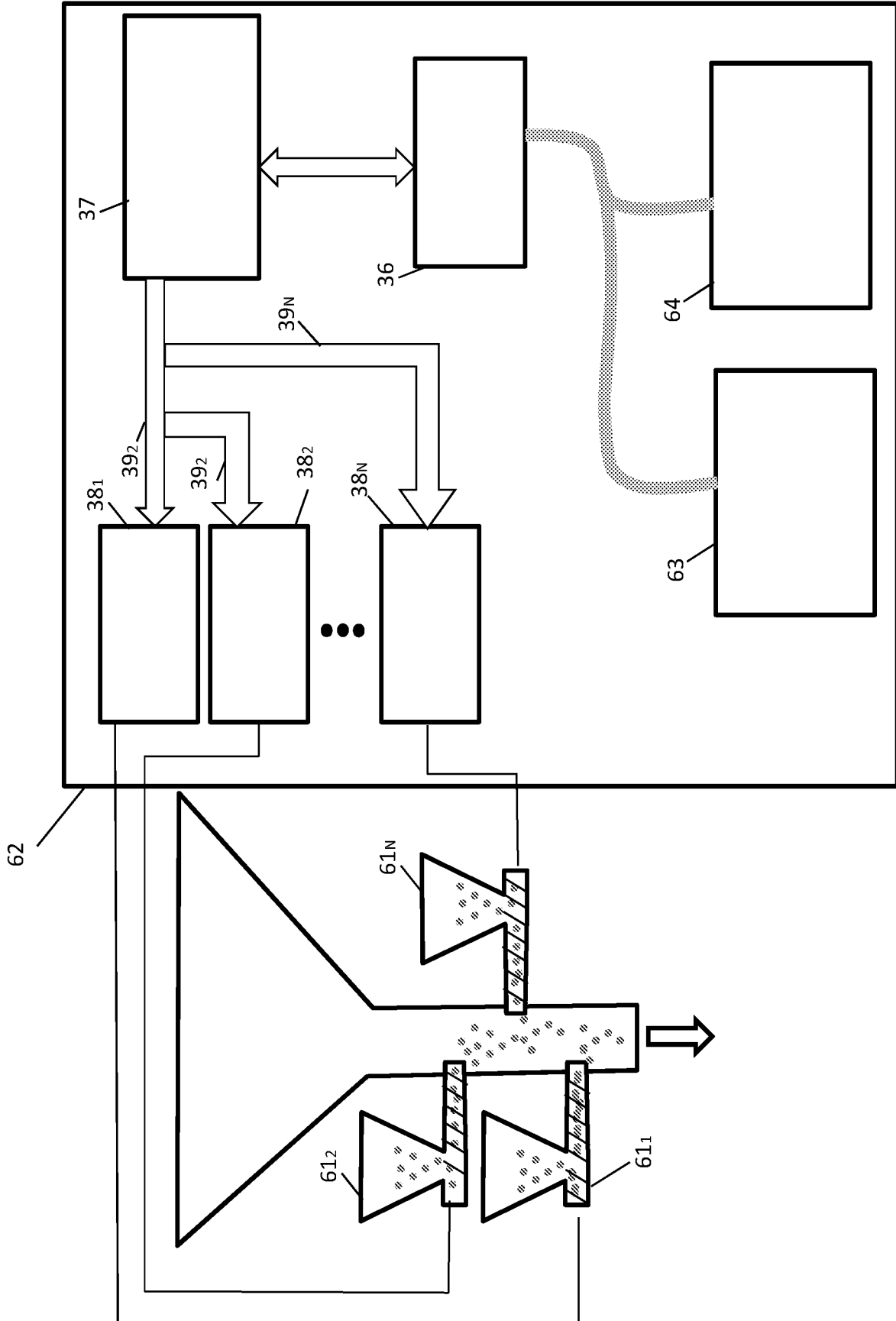

Fig. 6

11/20

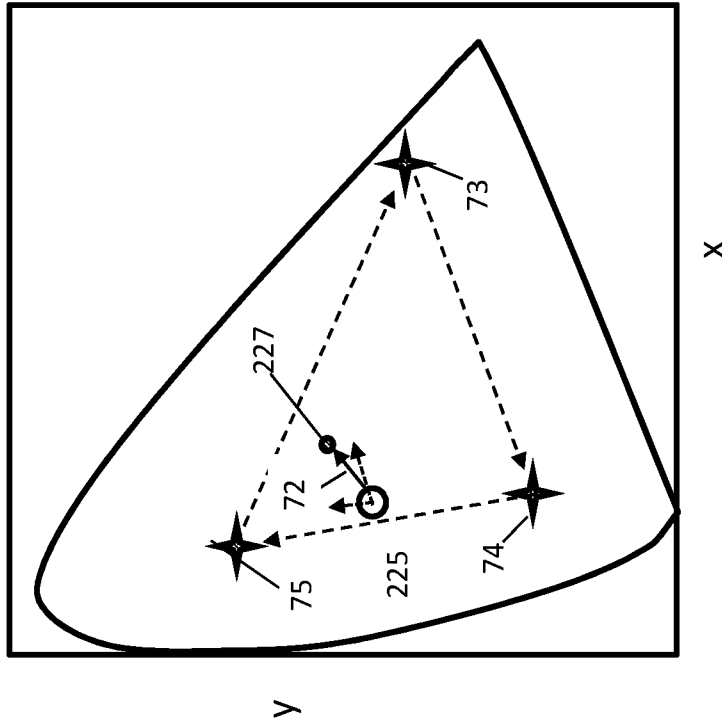

Fig. 7(b)

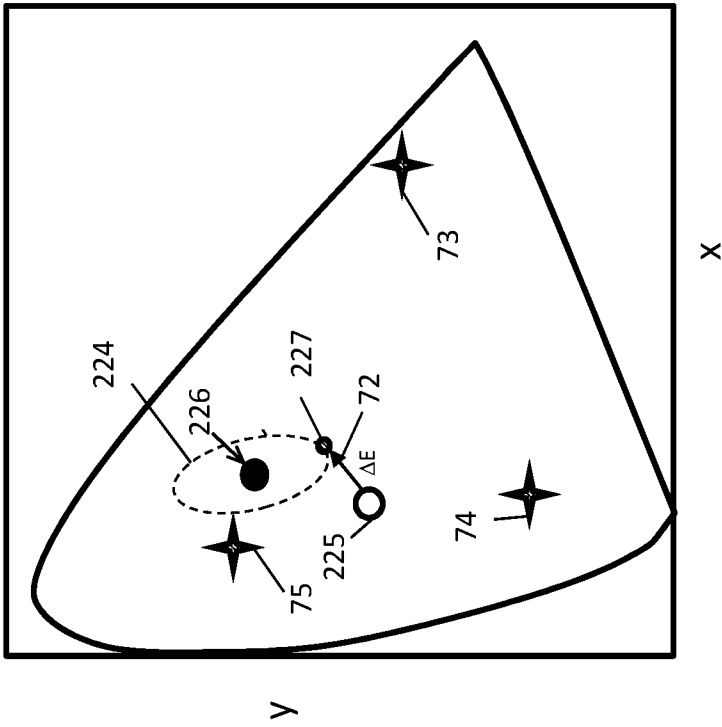

Fig. 7(a)

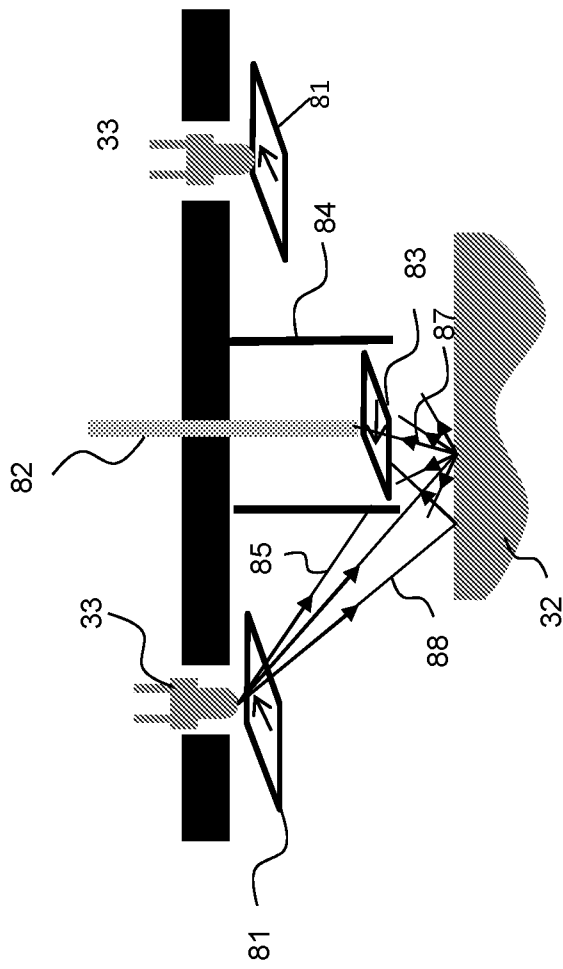

Fig. 8

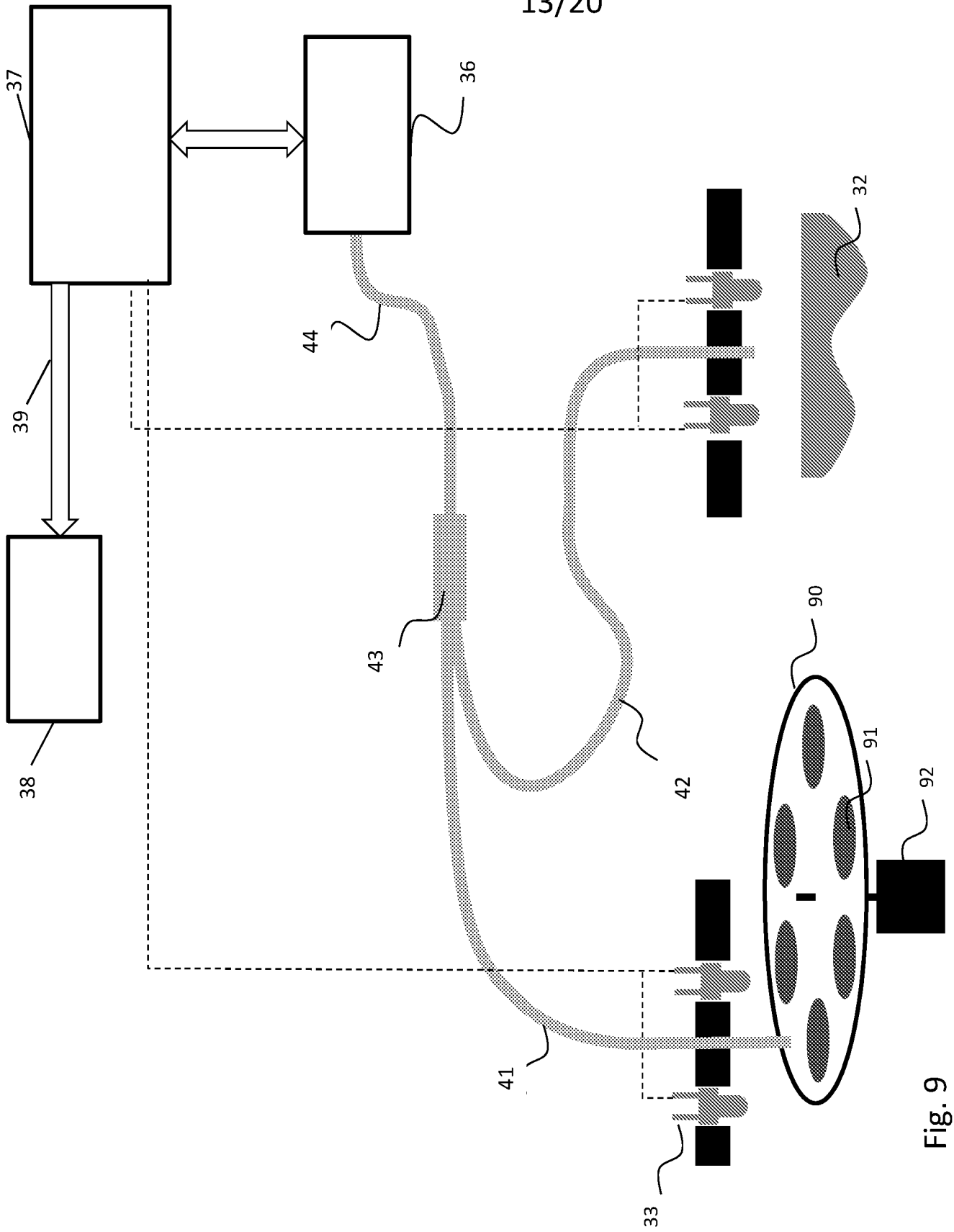

Fig. 9

14/20

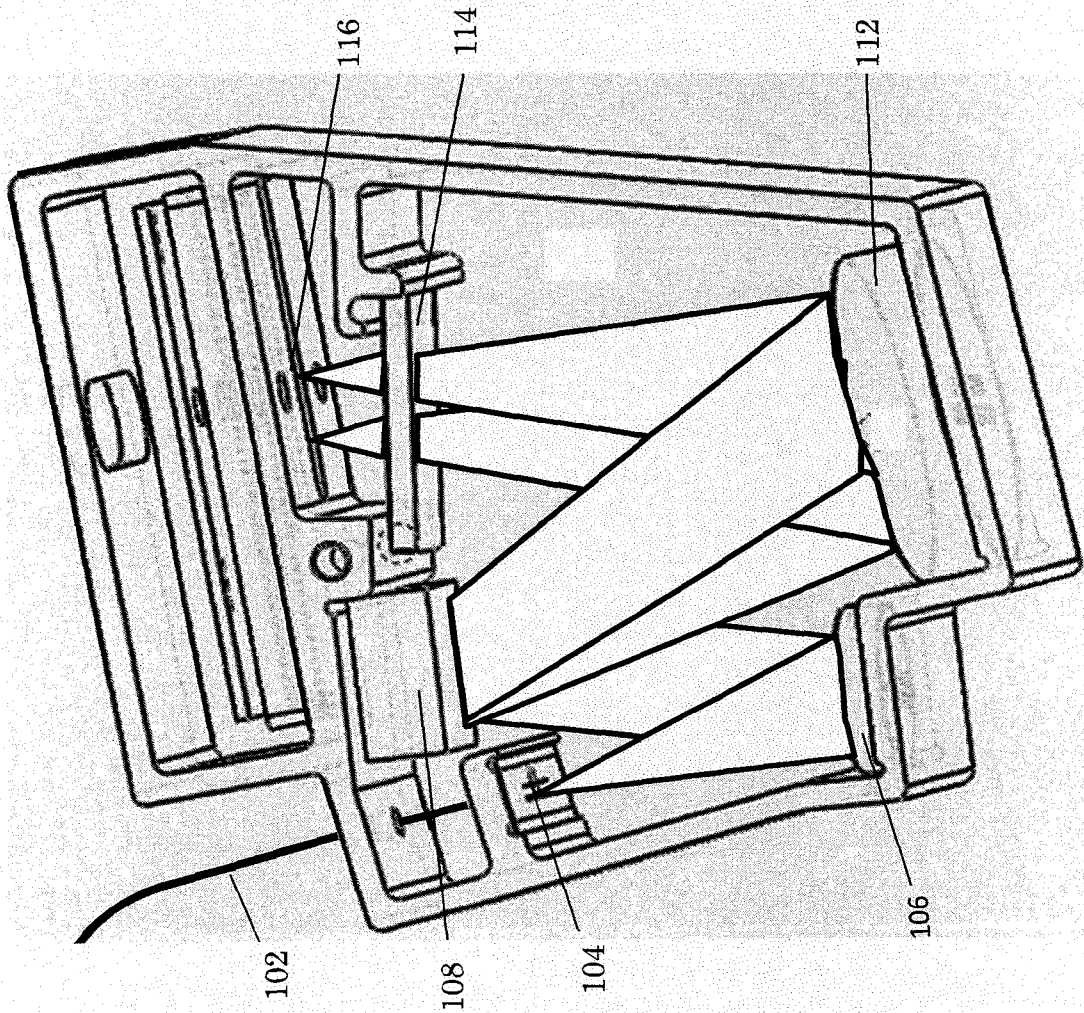

Fig. 10

15/20

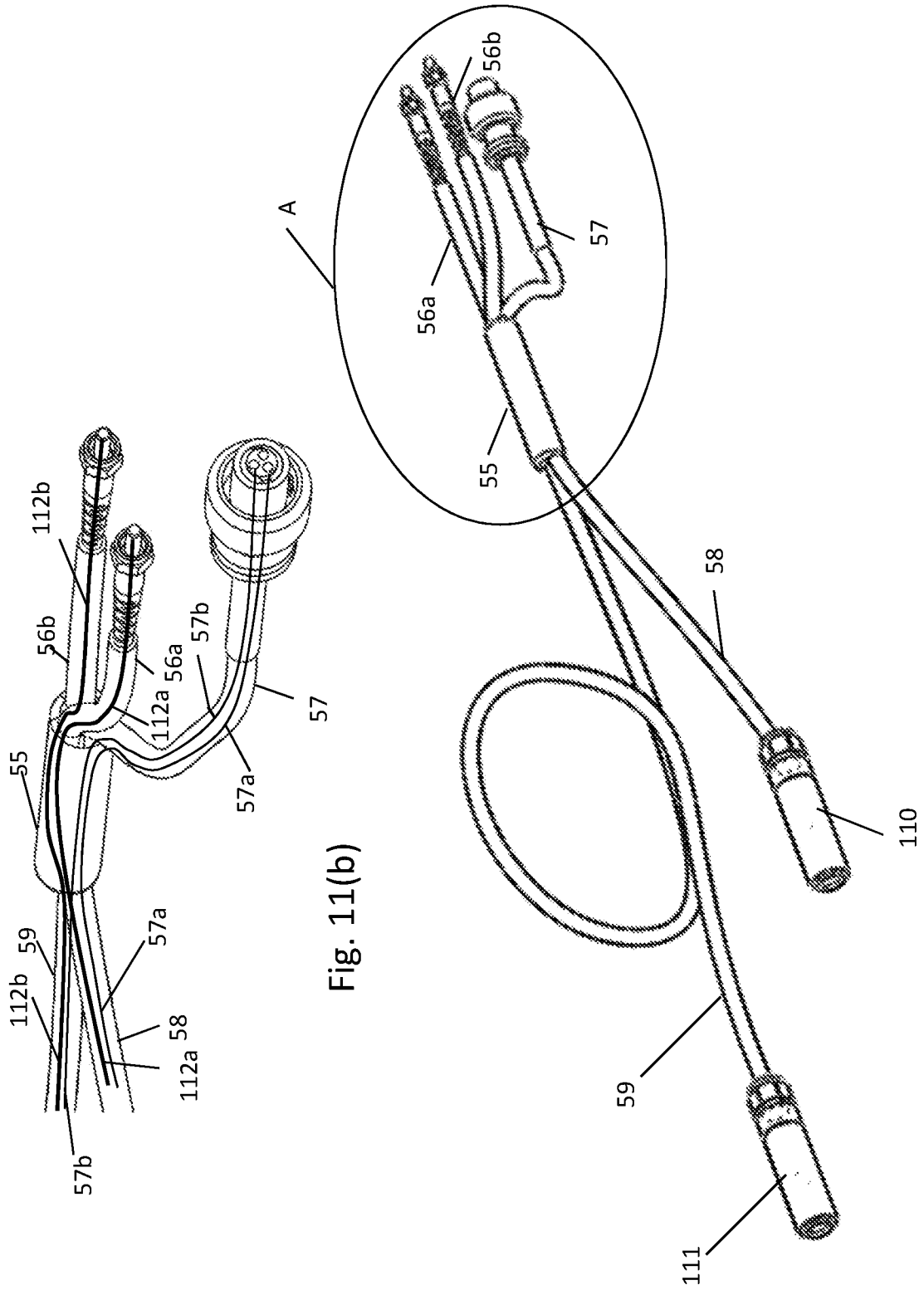

Fig. 11(a)

Fig. 11(b)

16/20

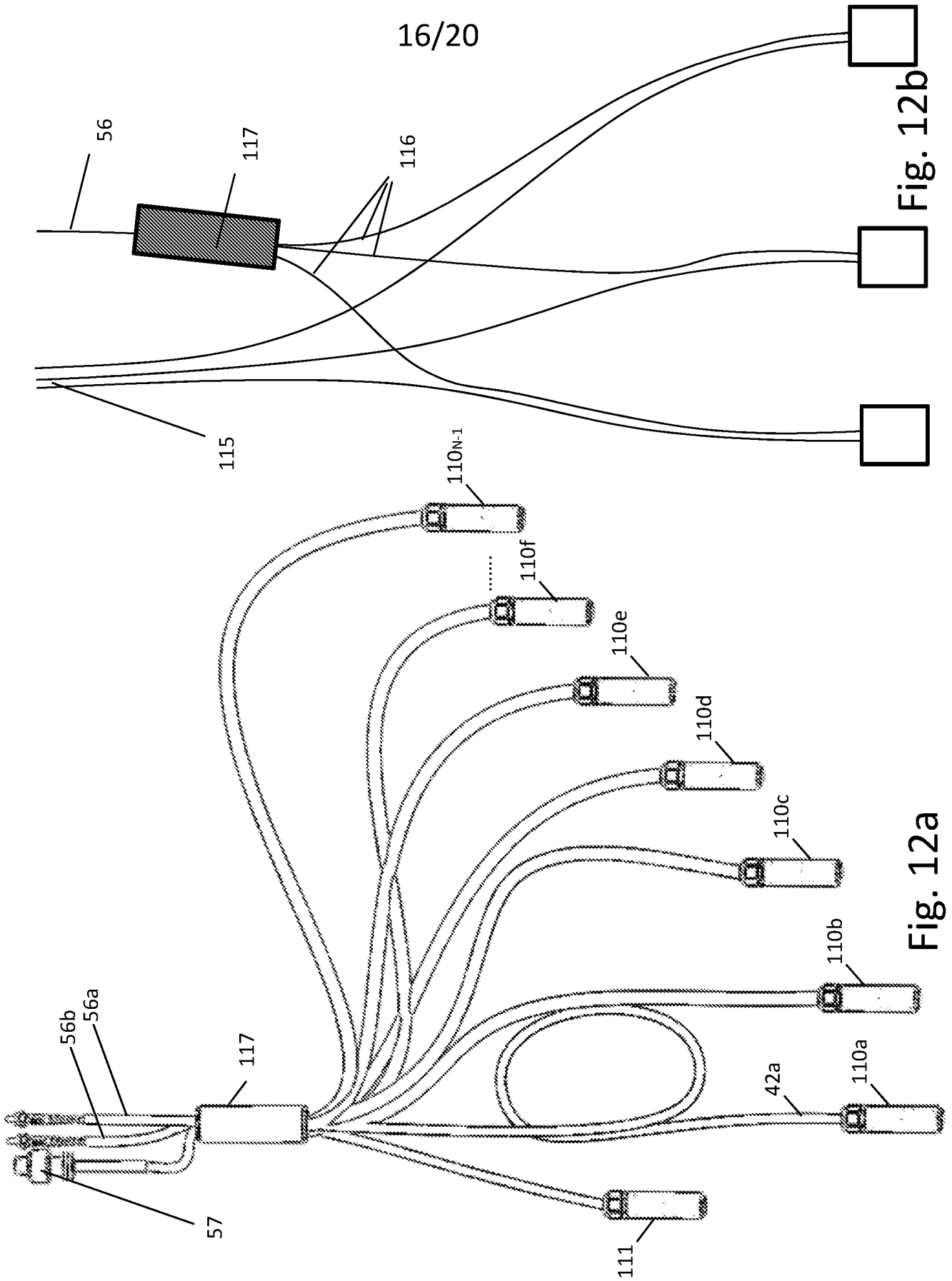

Fig. 12a



Fig. 12b

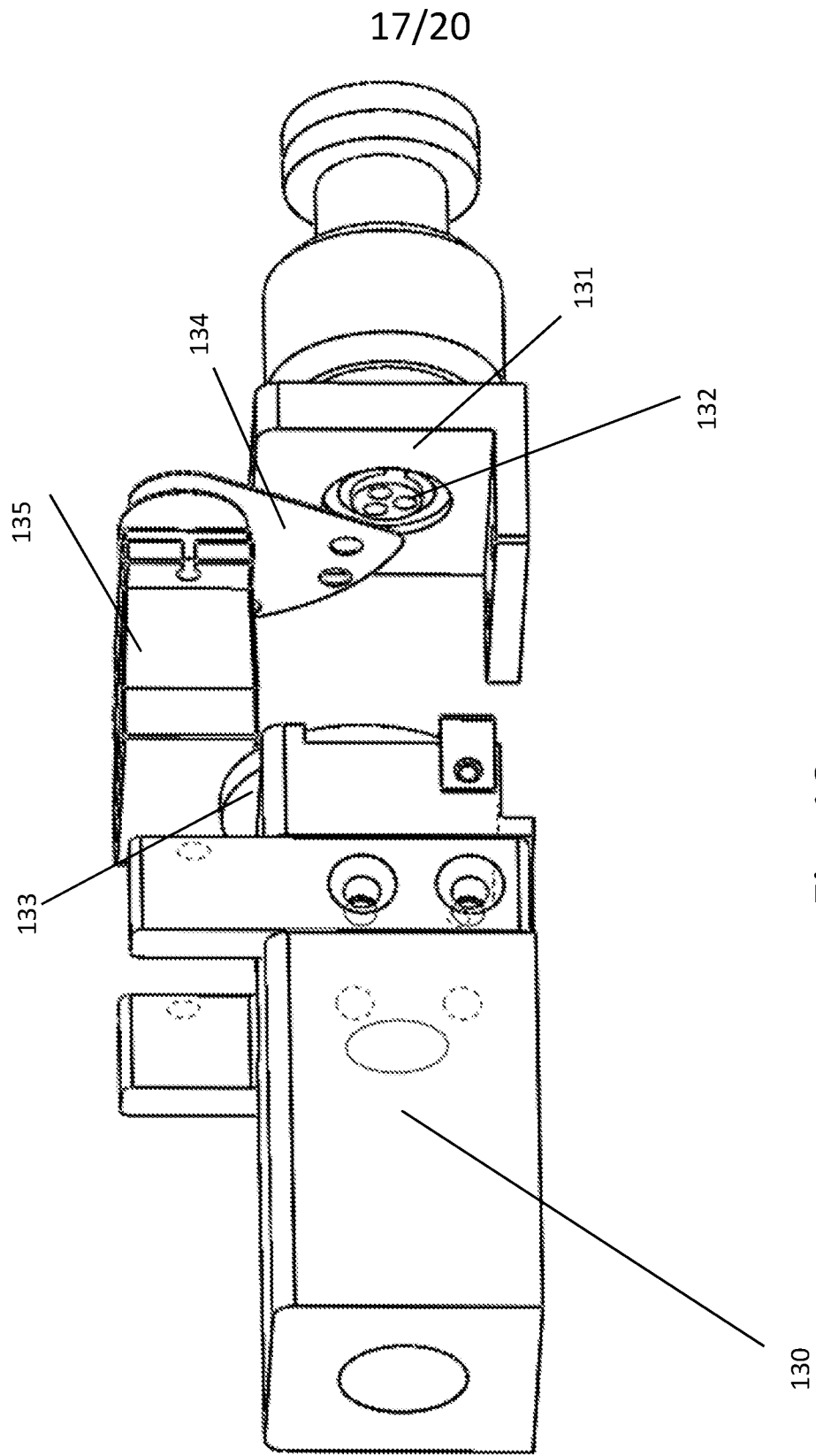

Fig. 13

18/20

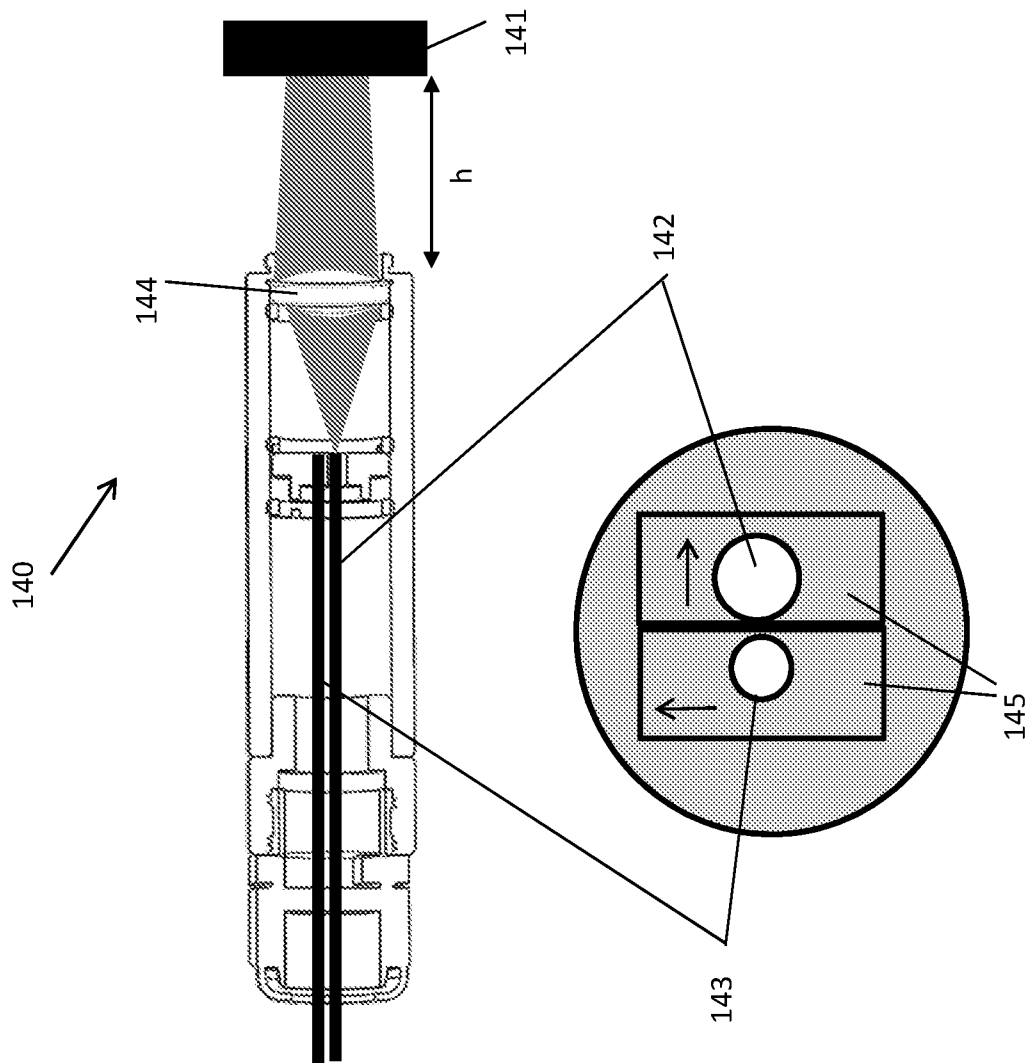

Fig. 14a

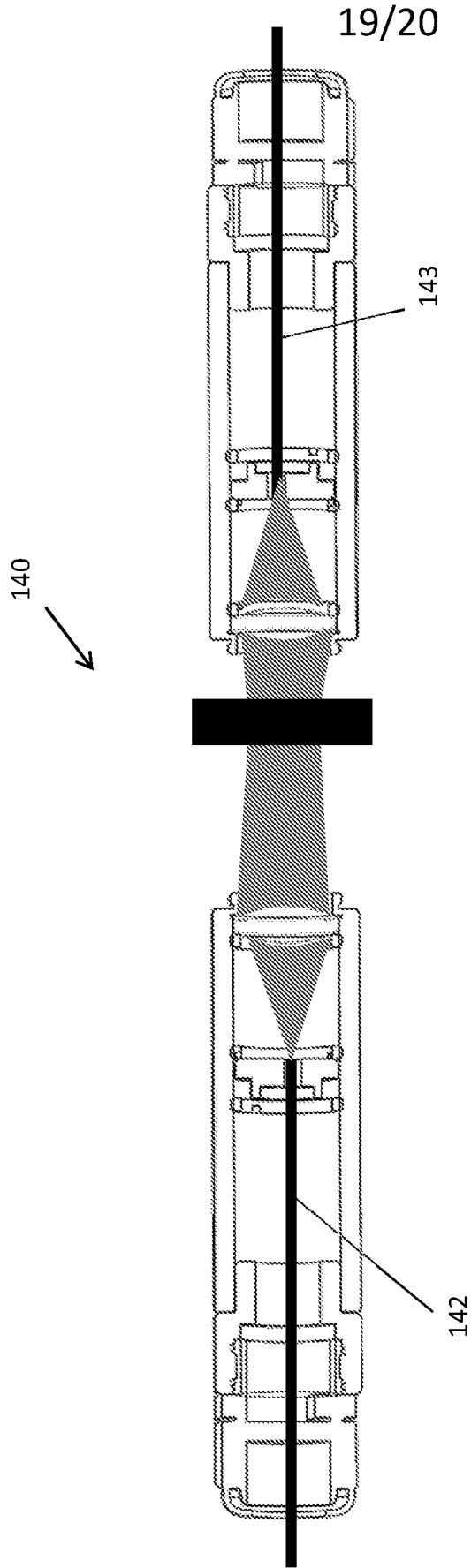

Fig. 14b

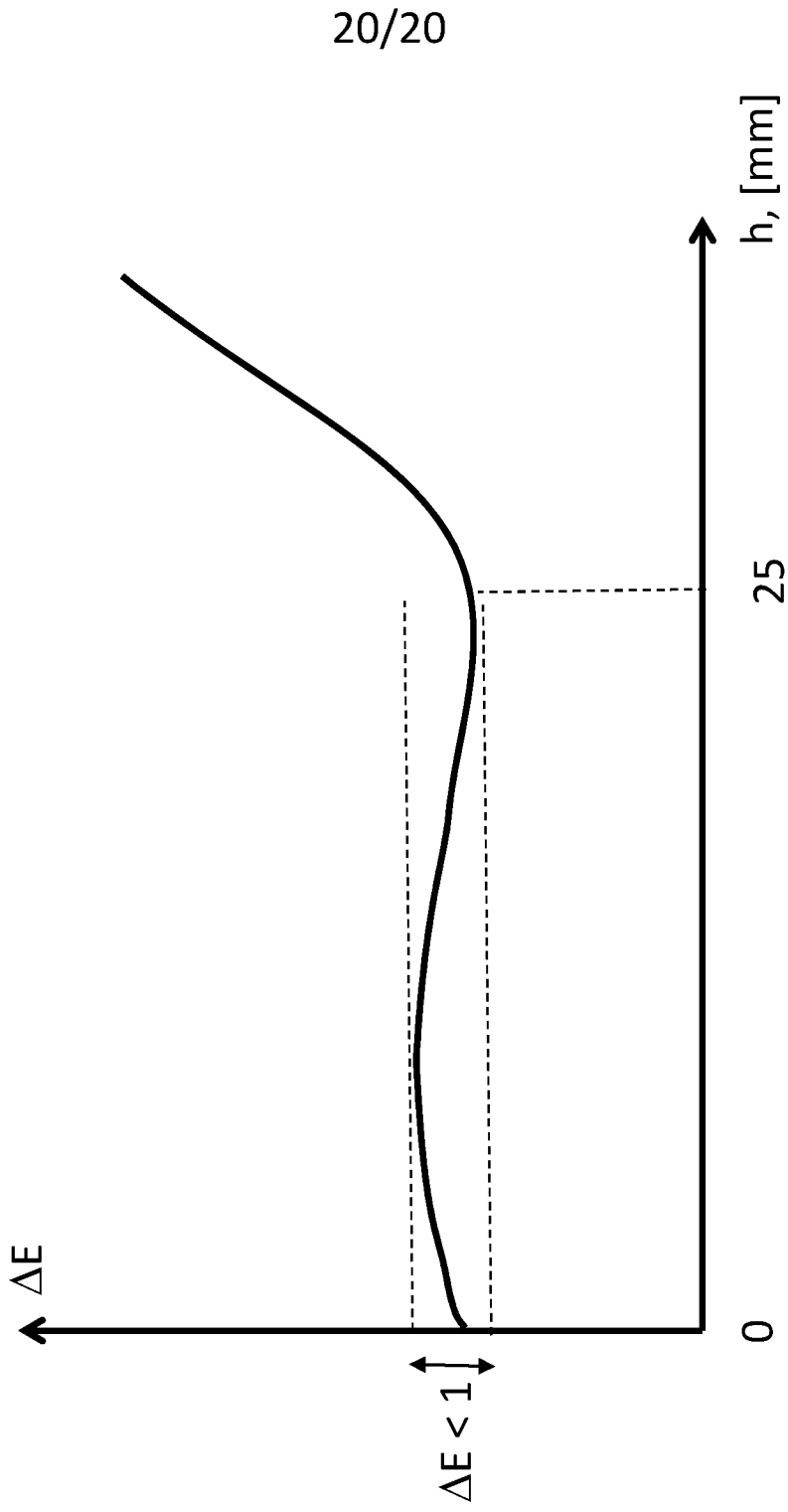

Fig. 14C

INTERNATIONAL SEARCH REPORT

International application No.

PCT/IL2015/050130

A. CLASSIFICATION OF SUBJECT MATTER IPC (2015.01) B01F 15/04, B29C 47/92, C08J 3/22, G01J 3/46, G05D 25/00, B29B 7/72 According to International Patent Classification (IPC) or to both national classification and IPC		
B. FIELDS SEARCHED Minimum documentation searched (classification system followed by classification symbols) IPC (2015.01) B29B, B29C, B01F, G01J, C08J Documentation searched other than minimum documentation to the extent that such documents are included in the fields searched Electronic data base consulted during the international search (name of data base and, where practicable, search terms used) Databases consulted: Google Patents, Google Scholar, FamPat database Search terms used: Masterbatch, colorant, feed, extruder, color sensor, spectrometer, color match, control, setpoint		
C. DOCUMENTS CONSIDERED TO BE RELEVANT		
Category*	Citation of document, with indication, where appropriate, of the relevant passages	Relevant to claim No.
Y A	US 4684488 A RUDOLPH J. 04 Aug 1987 (1987/08/04) Abstract ; Fig. 1 ; col. 2 lines 30-35 ; col. 4 lines 24-28	8-17 1-7
Y A	US 5723517 A CAMPO P. J. et al. 03 Mar 1998 (1998/03/03) Abstract ; Fig. 1 ; col. 5 lines 25-29 ; col. 9 lines 49-57 ; col. 16 lines 1-6	8-17 1-7
Y	US 6285453 B1 SMITH R. 04 Sep 2001 (2001/09/04) Abstract ; Fig. 1 & 2	8-17
Y	US 5568266 A CIZA J.-C. et al. 22 Oct 1996 (1996/10/22) Col. 8 line 57-col. 10 line 63 ; Fig. 5,6,8 & 10	12-14
<input type="checkbox"/> Further documents are listed in the continuation of Box C. <input checked="" type="checkbox"/> See patent family annex.		
* Special categories of cited documents: "A" document defining the general state of the art which is not considered to be of particular relevance "E" earlier application or patent but published on or after the international filing date "L" document which may throw doubts on priority claim(s) or which is cited to establish the publication date of another citation or other special reason (as specified) "O" document referring to an oral disclosure, use, exhibition or other means "P" document published prior to the international filing date but later than the priority date claimed "T" later document published after the international filing date or priority date and not in conflict with the application but cited to understand the principle or theory underlying the invention "X" document of particular relevance; the claimed invention cannot be considered novel or cannot be considered to involve an inventive step when the document is taken alone "Y" document of particular relevance; the claimed invention cannot be considered to involve an inventive step when the document is combined with one or more other such documents, such combination being obvious to a person skilled in the art "&" document member of the same patent family		
Date of the actual completion of the international search 28 May 2015		Date of mailing of the international search report 28 May 2015
Name and mailing address of the ISA: Israel Patent Office Technology Park, Bldg.5, Malcha, Jerusalem, 9695101, Israel Facsimile No. 972-2-5651616		Authorized officer GUTMAN Ariel Telephone No. 972-2-5657816

INTERNATIONAL SEARCH REPORT
Information on patent family membersInternational application No.
PCT/IL2015/050130

Patent document cited search report	Publication date	Patent family member(s)	Publication Date
US 4684488 A	04 Aug 1987	US 4684488 A	04 Aug 1987
		DE 3505036 A1	14 Aug 1986
		DE 3505036 C2	26 Feb 1987
		DE 3662491 D1	27 Apr 1989
		EP 0191338 A2	20 Aug 1986
		EP 0191338 A3	12 Nov 1986
		EP 0191338 B1	22 Mar 1989
		JP S61188124 A	21 Aug 1986
		JP H021648 B2	12 Jan 1990
US 5723517 A	03 Mar 1998	US 5723517 A	03 Mar 1998
		DE 69421990 D1	13 Jan 2000
		DE 69421990 T2	15 Jun 2000
		DE 69421990 T9	26 May 2011
		EP 0646409 A1	05 Apr 1995
		EP 0646409 B1	08 Dec 1999
		ES 2140510 T3	01 Mar 2000
		JP H07173295 A	11 Jul 1995
		JP 3143024 B2	07 Mar 2001
US 5559173 A	24 Sep 1996		
US 6285453 B1	04 Sep 2001	US 6285453 B1	04 Sep 2001
		US 6130752 A	10 Oct 2000
US 5568266 A	22 Oct 1996	US 5568266 A	22 Oct 1996