



US00D854458S

(12) **United States Design Patent**
Kermani

(10) **Patent No.:** **US D854,458 S**

(45) **Date of Patent:** **** Jul. 23, 2019**

(54) **DRIFTING KART**

(71) Applicant: **Ali Kermani**, Huntington Beach, CA (US)

(72) Inventor: **Ali Kermani**, Huntington Beach, CA (US)

(73) Assignee: **RAZOR USA LLC**, Cerritos, CA (US)

(**) Term: **15 Years**

(21) Appl. No.: **29/612,530**

(22) Filed: **Aug. 1, 2017**

D222,283 S * 10/1971 Reeves D21/426
3,799,283 A * 3/1974 Freber B60G 9/00
180/56
3,938,608 A 2/1976 Folco-Zambelli
(Continued)

FOREIGN PATENT DOCUMENTS

CN 2936826 8/2007
CN 200977859 11/2007
(Continued)

OTHER PUBLICATIONS

Aamoth, Doug, "Razor Builds the Ultimate Drifting Go-Kart: Why Must I Always Be Over the Weight Limit for Everything Good in This World?," Jul. 11, 2013, retrieved on Aug. 6, 2016, <http://techland.time.com/2013/07/11/razor-builds-the-ultimate-drifting-go-kart-why-must-i-always-be-over-the-weight-limit-for-everything-good-in-this-world/>, in 2 pages.
(Continued)

Primary Examiner — Darlington Ly
(74) *Attorney, Agent, or Firm* — Knobbe Martens Olson & Bear, LLP

(57) **CLAIM**

The ornamental design for a drifting kart, as shown and described.

DESCRIPTION

FIG. 1 is a top, front, and right-side perspective view of a drifting kart which embodies my design.
FIG. 2 is a top, rear, and left-side perspective view of the drifting kart of FIG. 1.
FIG. 3 is a top view of the drifting kart of FIG. 1.
FIG. 4 is a right side view of the drifting kart of FIG. 1.
FIG. 5 is a left side view of the drifting kart of FIG. 1.
FIG. 6 is a front view of the drifting kart of FIG. 1; and, FIG. 7 is a rear view of the drifting kart of FIG. 1.
Broken lines are used to illustrate portions of the drifting kart which form no part of the claimed design.

1 Claim, 6 Drawing Sheets

Related U.S. Application Data

(63) Continuation of application No. 29/564,412, filed on May 12, 2016, now Pat. No. Des. 793,912, which is a continuation of application No. 29/474,831, filed on May 9, 2014.

(51) **LOC (11) CL.** **12-11**

(52) **U.S. Cl.**
USPC **D12/112; D21/426**

(58) **Field of Classification Search**
USPC D21/412, 414, 431-435; D12/1, 107, D12/110-114, 129, 130, 133
CPC A63G 25/00; B62D 21/183; B62D 39/00; B60K 7/0007
See application file for complete search history.

References Cited

U.S. PATENT DOCUMENTS

3,062,559 A 6/1959 Hewitt
D189,614 S * 1/1961 Beale D12/88
D190,024 S * 4/1961 Rouse D12/88
3,125,177 A 3/1964 Paller
3,533,484 A * 10/1970 Wood, Jr. B60K 1/00
15/250.17

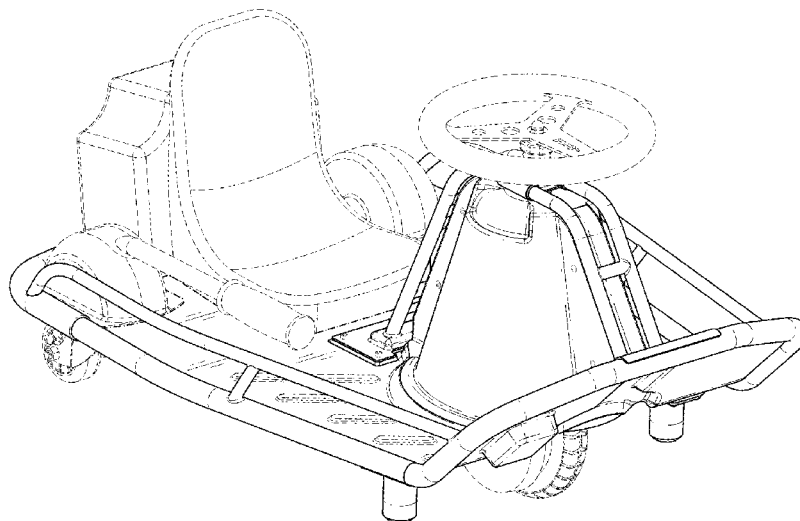

(56)

References Cited

U.S. PATENT DOCUMENTS

- 3,960,392 A * 6/1976 Read B62K 9/02
280/282
- D243,627 S * 3/1977 Clower D12/107
- D246,198 S * 10/1977 Rose D21/426
- D249,496 S * 9/1978 Morgan D12/112
- D252,714 S * 8/1979 Tidwell D21/426
- 4,281,844 A * 8/1981 Jackman B62K 9/02
280/263
- 4,359,231 A * 11/1982 Mulcahy B62D 9/02
280/288.1
- 4,403,673 A 9/1983 Ball
- D276,058 S * 10/1984 Rogers D21/426
- D280,916 S * 10/1985 Castle D21/426
- 4,572,535 A * 2/1986 Stewart B62K 3/005
280/266
- D290,451 S * 6/1987 Engum 280/259
- 4,750,578 A 6/1988 Brandenfels
- 4,826,190 A * 5/1989 Hartmann B62K 3/005
280/236
- 4,898,508 A 2/1990 Hayata
- 4,915,075 A 4/1990 Brown
- 4,944,360 A 7/1990 Sturges
- 4,993,733 A * 2/1991 Eilers B62K 3/005
280/261
- 5,036,938 A 8/1991 Blount et al.
- D320,420 S * 10/1991 Dupont D12/88
- D320,586 S * 10/1991 Tellinghuisen D12/112
- D332,765 S * 1/1993 Tellinghuisen D12/112
- D332,977 S * 2/1993 Huffman D21/423
- 5,257,671 A 11/1993 Watkins
- 5,265,690 A 11/1993 Amundsen et al.
- 5,477,936 A 12/1995 Sugioka et al.
- 5,479,998 A 1/1996 Ishikawa
- 5,494,126 A 2/1996 Meeker
- D369,130 S * 4/1996 Cummings D12/112
- D378,226 S * 2/1997 Sundqvist D21/433
- 5,628,379 A 5/1997 Watkins
- 5,826,670 A 10/1998 Nan
- D408,869 S * 4/1999 Patmont D21/424
- 5,904,218 A 5/1999 Watkins
- 6,026,923 A 2/2000 Uphaus
- 6,047,786 A 4/2000 Stevenson et al.
- D440,607 S * 4/2001 Mahlow D21/419
- 6,276,480 B1 8/2001 Aregger
- 6,349,786 B1 2/2002 Gift
- D460,723 S * 7/2002 Smit D12/112
- D466,560 S 12/2002 Stolpmann
- D469,819 S * 2/2003 Nicolle D21/426
- D483,420 S 12/2003 Delong et al.
- D488,194 S 4/2004 Fox et al.
- 6,729,421 B1 5/2004 Gluck
- 6,749,039 B1 6/2004 Uphaus
- 6,766,871 B2 7/2004 Sawyer
- D512,467 S * 12/2005 Hadley D21/424
- 7,117,967 B2 10/2006 Kidd
- 7,198,322 B2 4/2007 Savo
- D562,914 S 2/2008 Oveson et al.
- D570,572 S 6/2008 Whiteside et al.
- D574,297 S 8/2008 Carl
- D575,675 S 8/2008 Williams et al.
- D582,992 S * 12/2008 Alais D21/426
- 7,552,934 B2 * 6/2009 Lee B62K 3/005
280/266
- D608,250 S * 1/2010 Van De Vrie D12/112
- D611,106 S 3/2010 Van Beek
- 7,712,558 B2 5/2010 Helson et al.
- 7,823,675 B2 11/2010 Kermani
- D637,116 S 5/2011 Kettler
- D637,660 S 5/2011 Markowitz
- 8,091,658 B2 1/2012 Peng
- 8,356,686 B2 1/2013 Kermani
- 8,365,850 B2 2/2013 Gal et al.
- D682,746 S 5/2013 Doherty et al.
- D692,505 S * 10/2013 Jiang D12/112
- D692,506 S * 10/2013 Jiang D12/112
- 8,801,005 B1 8/2014 Flickner et al.
- 8,875,831 B2 11/2014 Kermani
- 9,102,375 B2 8/2015 Kermani
- 9,139,248 B2 9/2015 Xiao
- D761,700 S * 7/2016 Kermani D12/112
- D766,780 S * 9/2016 Fusco D12/112
- D771,196 S * 11/2016 Chen D21/424
- 9,499,220 B2 11/2016 Kermani
- D774,602 S 12/2016 Desberg
- D774,981 S * 12/2016 Chen D12/112
- D775,282 S 12/2016 Williams et al.
- D778,369 S 2/2017 Douma et al.
- D783,726 S 4/2017 Williams et al.
- D787,379 S 5/2017 Kermani
- D792,811 S 7/2017 Kermani et al.
- D793,480 S 8/2017 Chen
- D793,481 S 8/2017 Kermani et al.
- D793,912 S 8/2017 Kermani
- D807,438 S 1/2018 Desberg
- D820,733 S 6/2018 Chen
- D830,469 S 10/2018 Kermani et al.
- D830,470 S 10/2018 Chen
- 2004/0035627 A1 2/2004 Richey et al.
- 2004/0040769 A1 3/2004 Richey et al.
- 2004/0199311 A1 * 10/2004 Aguilar G09B 9/042
701/36
- 2007/0045022 A1 3/2007 Greig et al.
- 2008/0122209 A1 5/2008 Jayasuriya
- 2008/0196951 A1 8/2008 Gal et al.
- 2009/0065272 A1 3/2009 Martin et al.
- 2010/0032223 A1 * 2/2010 Kermani A63G 25/00
180/216
- 2011/0042912 A1 2/2011 Kermani
- 2012/0133111 A1 5/2012 Schmutzer et al.
- 2017/0156953 A1 6/2017 Kermani
- 2018/0029458 A1 2/2018 Chen et al.
- 2018/0043950 A1 2/2018 Kermani et al.

FOREIGN PATENT DOCUMENTS

- CN 201009762 Y 1/2008
- CN 203186508 U 9/2013
- CN 203427959 U 2/2014
- EP 0529188 A1 3/1993
- WO WO 2018/035060 A1 2/2018

OTHER PUBLICATIONS

- OTL Electrokart, "Storm Series—Competition" Datasheet, Jun. 14, 2014, retrieved on Aug. 6, 2016, <https://www.kart1.com/pdf/competition.pdf>, in 3 pages.
- International Written Opinion of International Patent Application No. PCT/CN2017/072086, dated May 19, 2017.

* cited by examiner

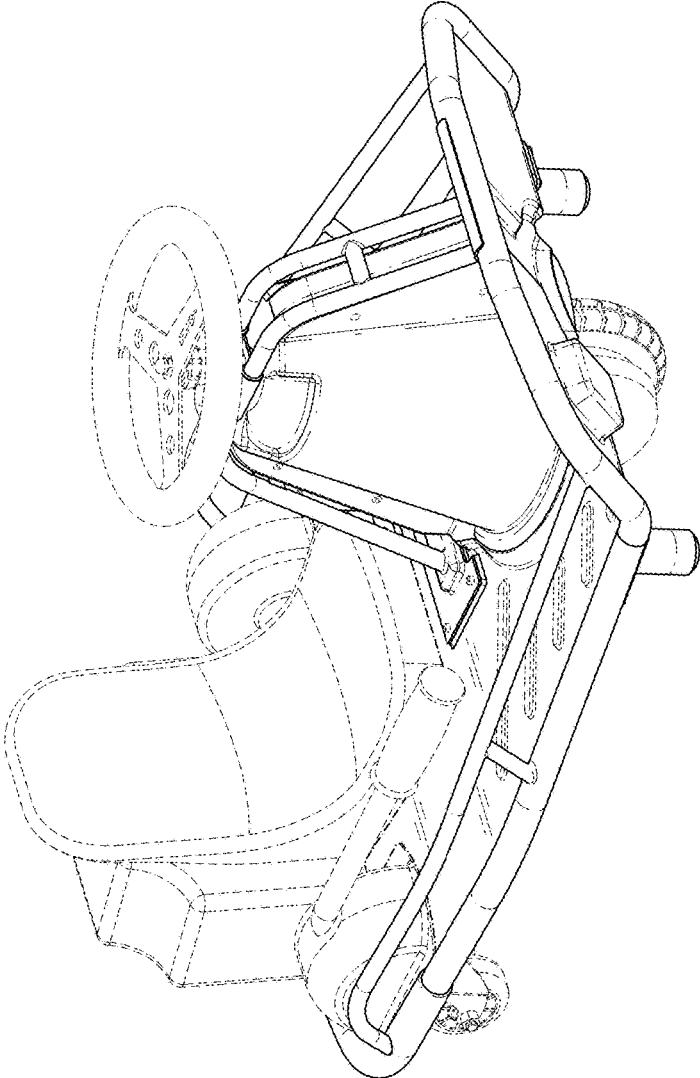

FIG. 1

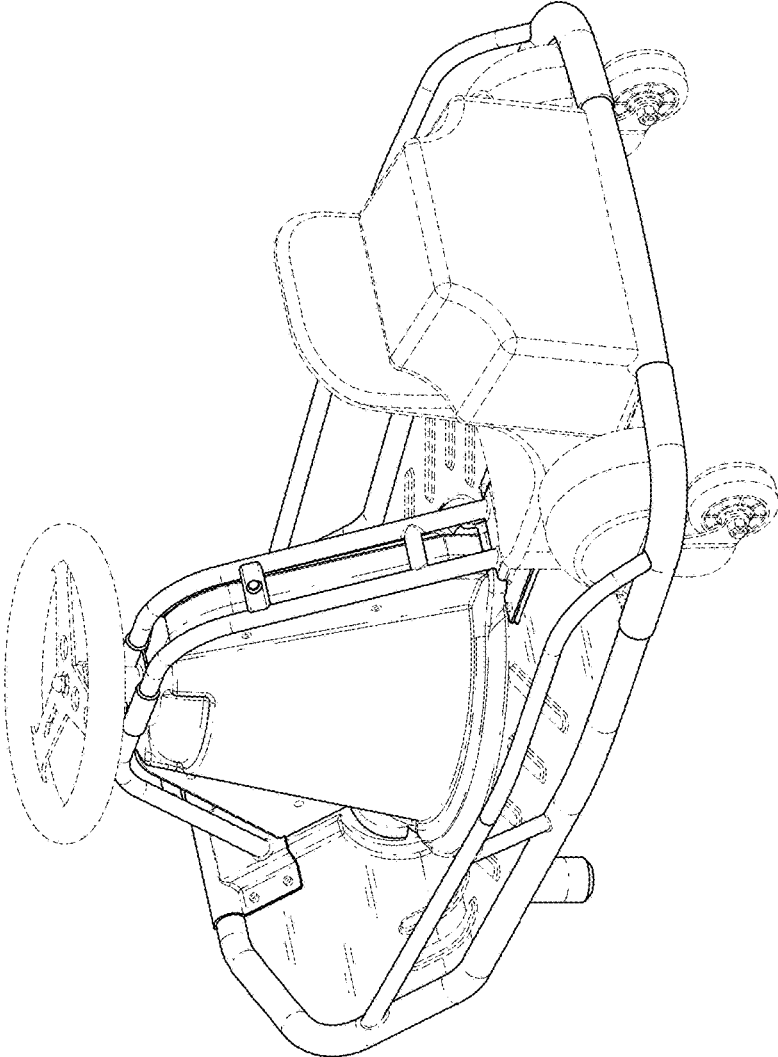

FIG. 2

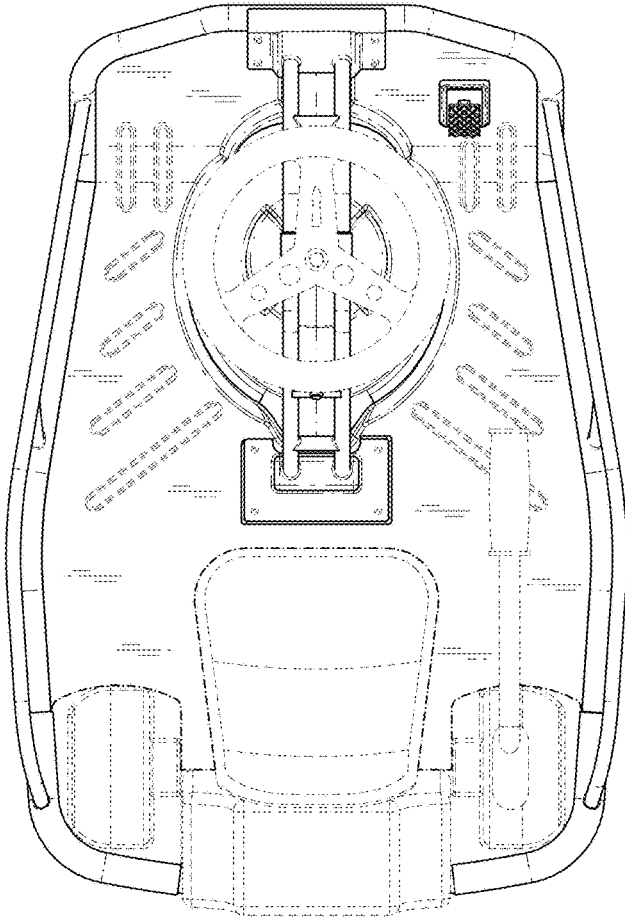

FIG. 3

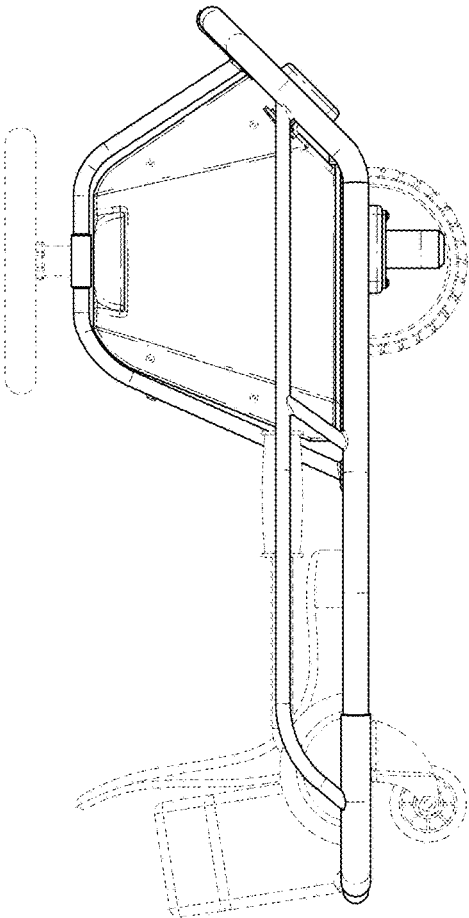

FIG. 4

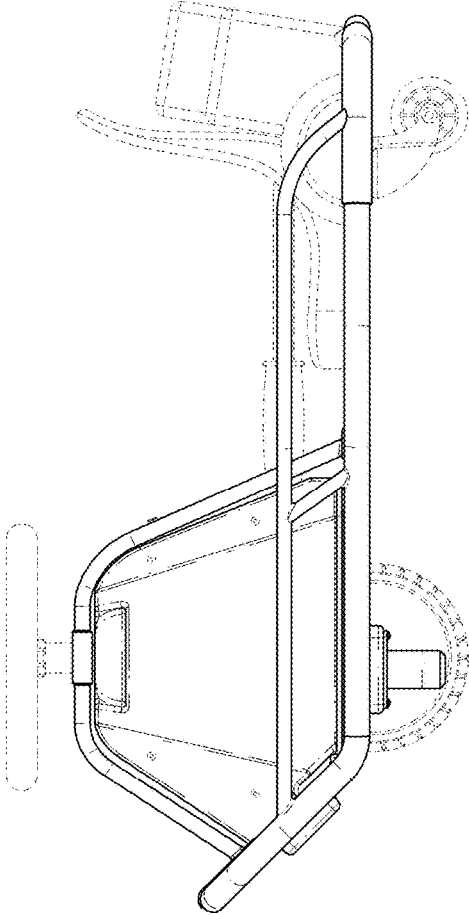

FIG. 5

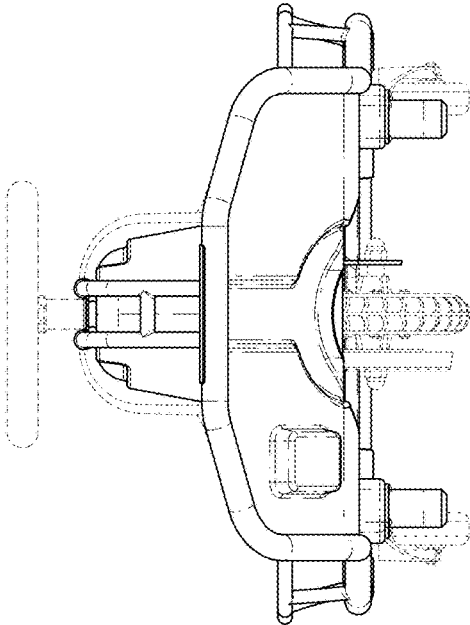

FIG. 6

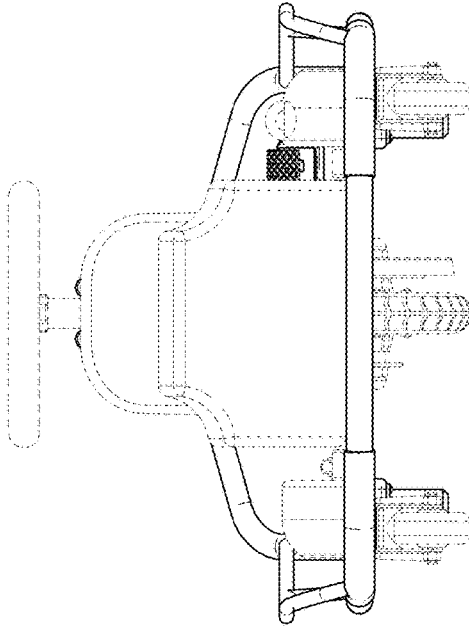

FIG. 7