

[54] RAIL SUPPORT FITTING FOR A DOUBLE POST, RAIL FENCE UNIT OR THE LIKE

3,604,687 9/1971 Moore 256/65
 3,778,537 12/1973 Miller 248/74.3
 4,186,902 2/1980 Simons 248/73

[76] Inventor: John Allen, 5897 Avenue Juan Bautista, Riverside, Calif. 92509

Primary Examiner—Wallace R. Burke
 Assistant Examiner—Horace B. Fay, Jr.
 Attorney, Agent, or Firm—John H. Crowe

[**] Term: 14 Years

[21] Appl. No.: 241,134

[57] CLAIM

[22] Filed: Mar. 6, 1981

The ornamental design for a rail support fitting for a double post, rail fence unit or the like, substantially as shown and described.

[52] U.S. Cl. D8/354

[58] Field of Search D8/354, 356, 394, 396; 248/73, 74.3, 74.1, 74.5; 256/65, 68, 69; D25/38, 43, 44

DESCRIPTION

[56] References Cited

U.S. PATENT DOCUMENTS

D. 250,875	1/1979	Lindblom	D8/396
D. 250,876	1/1979	Lindblom	D8/396
D. 255,869	7/1980	Glynn et al.	D8/356
D. 256,663	9/1980	Gelb	D8/354
D. 260,481	9/1981	Norcross et al.	D8/394
340,263	4/1886	Weber	256/68
2,904,314	9/1959	Thom	D25/43
3,524,627	8/1970	Boyanton et al.	256/65

FIG. 1 is a perspective view of a rail support fitting for a double post, rail fence unit, or the like showing my new design;
 FIG. 2 is a front elevational view thereof, and the rear view thereof being substantially a mirror image of the front elevational view;
 FIG. 3 is a bottom plan view thereof;
 FIG. 4 is a top plan view thereof;
 FIG. 5 is a side elevational view thereof, and the opposite side elevational view being substantially a mirror image thereof.

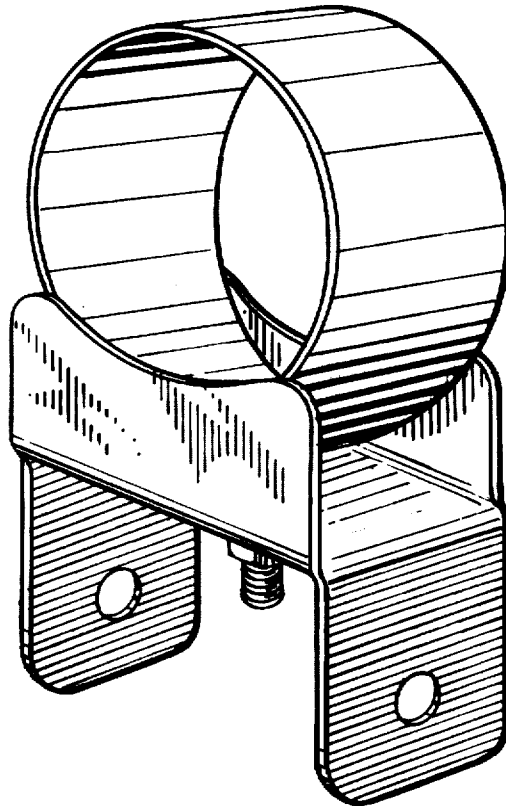

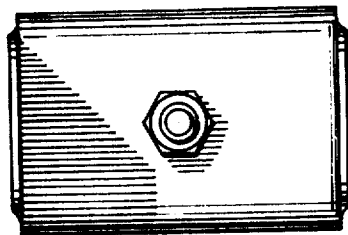
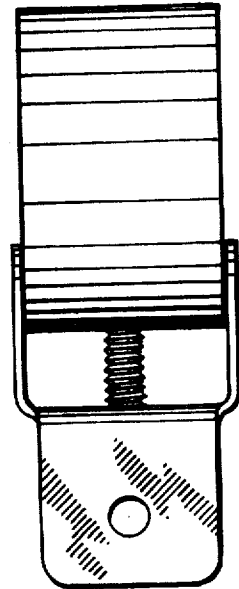
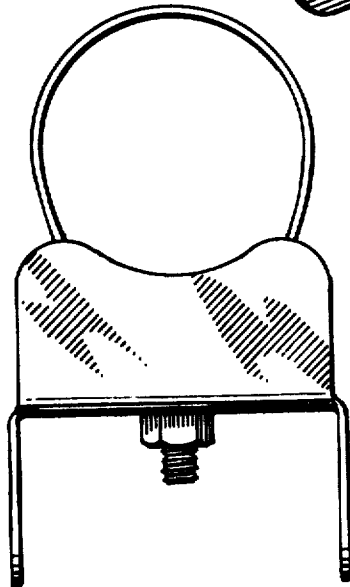
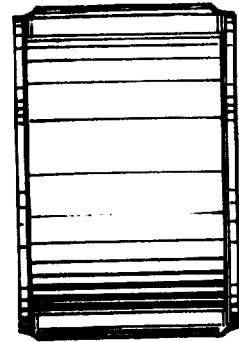
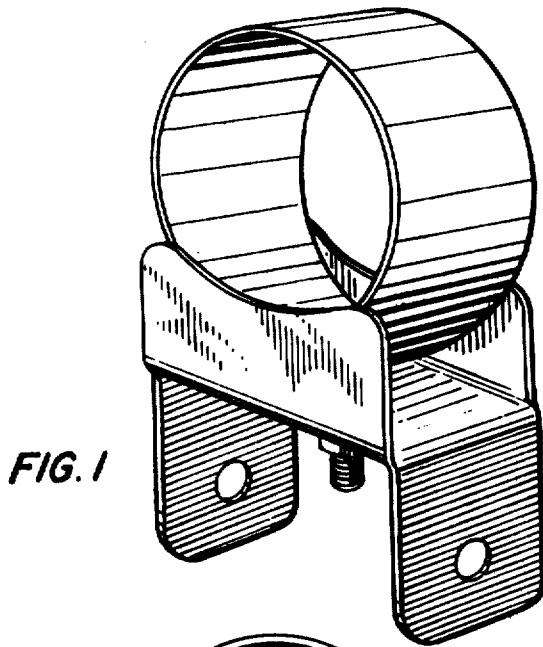

FIG. 3