



- (51) International Patent Classification:
H01G 4/14 (2006.01)
- (21) International Application Number:
PCT/US2015/030415
- (22) International Filing Date:
12 May 2015 (12.05.2015)
- (25) Filing Language: English
- (26) Publication Language: English
- (30) Priority Data:
61/991,861 12 May 2014 (12.05.2014) US
- (71) Applicant: **CAPACITOR SCIENCES INCORPORATED** [US/US]; 1455 Adams Drive, Menlo Park, CA 94025 (US).
- (72) Inventor: **LAZAREV, Pavel, Ivan**; 808 Coleman Avenue, Apt. 18, Menlo Park, CA 94025 (US).
- (74) Agents: **ALEMOZAFAR, Ali** et al.; Wilson Sonsini Goodrich & Rosati, 650 Page Mill Road, Palo Alto, CA 94304-1050 (US).
- (81) Designated States (*unless otherwise indicated, for every kind of national protection available*): AE, AG, AL, AM, AO, AT, AU, AZ, BA, BB, BG, BH, BN, BR, BW, BY, BZ, CA, CH, CL, CN, CO, CR, CU, CZ, DE, DK, DM,

DO, DZ, EC, EE, EG, ES, FI, GB, GD, GE, GH, GM, GT, HN, HR, HU, ID, IL, IN, IR, IS, JP, KE, KG, KN, KP, KR, KZ, LA, LC, LK, LR, LS, LU, LY, MA, MD, ME, MG, MK, MN, MW, MX, MY, MZ, NA, NG, NI, NO, NZ, OM, PA, PE, PG, PH, PL, PT, QA, RO, RS, RU, RW, SA, SC, SD, SE, SG, SK, SL, SM, ST, SV, SY, TH, TJ, TM, TN, TR, TT, TZ, UA, UG, US, UZ, VC, VN, ZA, ZM, ZW.

(84) Designated States (*unless otherwise indicated, for every kind of regional protection available*): ARIPO (BW, GH, GM, KE, LR, LS, MW, MZ, NA, RW, SD, SL, ST, SZ, TZ, UG, ZM, ZW), Eurasian (AM, AZ, BY, KG, KZ, RU, TJ, TM), European (AL, AT, BE, BG, CH, CY, CZ, DE, DK, EE, ES, FI, FR, GB, GR, HR, HU, IE, IS, IT, LT, LU, LV, MC, MK, MT, NL, NO, PL, PT, RO, RS, SE, SI, SK, SM, TR), OAPI (BF, BJ, CF, CG, CI, CM, GA, GN, GQ, GW, KM, ML, MR, NE, SN, TD, TG).

Published:

- with international search report (Art. 21(3))
- before the expiration of the time limit for amending the claims and to be republished in the event of receipt of amendments (Rule 48.2(h))

(88) Date of publication of the international search report:
7 January 2016

(54) Title: ENERGY STORAGE DEVICE AND METHOD OF PRODUCTION THEREOF

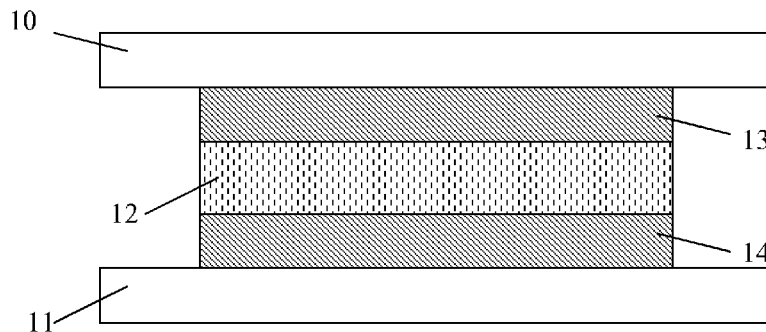
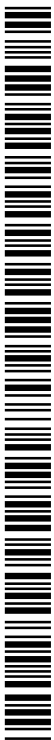

Figure 2

(57) Abstract: The present invention relates generally to the fields of electrical engineering and electronics. More specifically, the present invention relates to passive components of electrical circuitry and more particularly to energy storage devices and method of production thereof. The present invention provides an energy storage device comprising a first electrode, a second electrode, and a solid multilayer structure disposed between said first and second electrodes. Said electrodes are flat and planar and positioned parallel to each other, and said solid multilayer structure comprises m homogeneous insulating and conductive layers.



ENERGY STORAGE DEVICE AND METHOD OF PRODUCTION THEREOF**CROSS-REFERENCE**

[0001] This application claims the benefit of U.S. Provisional Application No. 61/991,861, filed May 12, 2014, which is entirely incorporated herein by reference.

FIELD OF THE INVENTION

[0002] The present invention relates generally to passive components of electrical circuit and more particularly to energy storage devices and method of production thereof.

BACKGROUND OF THE INVENTION

[0003] A capacitor is a passive electronic component that is used to store energy in the form of an electrostatic field, and comprises a pair of electrodes separated by a dielectric layer. When a potential difference exists between two electrodes, an electric field is present in the dielectric layer. This field stores energy and an ideal capacitor is characterized by a single constant value of capacitance which is a ratio of the electric charge on each electrode to the potential difference between them. In practice, the dielectric layer between electrodes passes a small amount of leakage current. Electrodes and leads introduce an equivalent series resistance, and dielectric layer has limitation to an electric field strength which results in a breakdown voltage. The simplest energy storage device consists of two parallel electrodes separated by a dielectric layer of permittivity ϵ , each of the electrodes has an area S and is placed on a distance d from each other. Electrodes are considered to extend uniformly over an area S , and a surface charge density can be expressed by the equation: $\pm\rho = \pm Q/S$. As the width of the electrodes is much greater than the separation (distance) d , an electrical field near the centre of the capacitor will be uniform with the magnitude $E = \rho/\epsilon$. Voltage is defined as a line integral of the electric field between electrodes. An ideal capacitor is characterized by a constant capacitance C defined by the formula (1)

$$C = Q/V, \quad (1)$$

which shows that capacitance increases with area and decreases with distance. Therefore the capacitance is largest in devices made of materials of high permittivity.

[0004] A characteristic electric field known as the breakdown strength E_{bd} , is an electric field in which the dielectric layer in a capacitor becomes conductive. Voltage at which this occurs is called the breakdown voltage of the device, and is given by the product of dielectric strength and separation between the electrodes,

$$V_{bd} = E_{bd}d \quad (2)$$

[0005] The maximal volumetric energy density stored in the capacitor is limited by the value proportional to $\sim \varepsilon \cdot E_{bd}^2$, where ε is dielectric permittivity and E_{bd} is breakdown strength.

Thus, in order to increase the stored energy of the capacitor it is necessary to increase dielectric permeability ε and breakdown strength E_{bd} of the dielectric.

[0006] For high voltage applications much larger capacitors have to be used. There are a number of factors that can dramatically reduce the breakdown voltage. Geometry of the conductive electrodes is important for these applications. In particular, sharp edges or points hugely increase the electric field strength locally and can lead to a local breakdown. Once a local breakdown starts at any point, the breakdown will quickly "trace" through the dielectric layer till it reaches the opposite electrode and causes a short circuit.

[0007] Breakdown of the dielectric layer usually occurs as follows. Intensity of an electric field becomes high enough free electrons from atoms of the dielectric material and make them conduct an electric current from one electrode to another. Presence of impurities in the dielectric or imperfections of the crystal structure can result in an avalanche breakdown as observed in semiconductor devices.

[0008] Other important characteristic of a dielectric material is its dielectric permittivity. Different types of dielectric materials are used for capacitors and include ceramics, polymer film, paper, and electrolytic capacitors of different kinds. The most widely used polymer film materials are polypropylene and polyester. Increase of dielectric permittivity allows increasing of volumetric energy density which makes it an important technical task.

[0009] An ultra-high dielectric constant composite of polyaniline, PANI-DBSA/PAA, was synthesized using in situ polymerization of aniline in an aqueous dispersion of poly-acrylic acid (PAA) in the presence of dodecylbenzene sulfonate (DBSA) (see, Chao-Hsien Hoa et al., "High dielectric constant polyaniline/poly(acrylic acid) composites prepared by in situ polymerization", *Synthetic Metals* 158 (2008), pp. 630–637). The water-soluble PAA served as a polymeric stabilizer, protecting the PANI particles from macroscopic aggregation. A very high dielectric constant of ca. $2.0 \cdot 10^5$ (at 1 kHz) was obtained for the composite containing 30% PANI by weight. Influence of the PANI content on the morphological, dielectric and electrical properties of the composites was investigated. Frequency dependence of dielectric permittivity, dielectric loss, loss tangent and electric modulus were analyzed in the frequency range from 0.5 kHz to 10 MHz. SEM micrograph revealed that composites with high PANI content (i.e., 20 wt.%) consisted of numerous nano-scale PANI particles that were evenly distributed within the PAA matrix. High dielectric constants were attributed to the sum of the small capacitors of the PANI particles. The drawback of this material is a possible occurrence of percolation and formation of at least one continuous conductive path under electric field with probability of such an event

increasing with an increase of the electric field. When at least one continuous path (track) through the neighboring conducting PANI particles is formed between electrodes of the capacitor, it decreases a breakdown voltage of such a capacitor.

[0010] Single crystals of doped aniline oligomers are produced via a simple solution-based self-assembly method (see, Yue Wang, et. al., “Morphological and Dimensional Control via Hierarchical Assembly of Doped Oligoaniline Single Crystals”, J. Am. Chem. Soc. 2012, 134, pp. 9251–9262). Detailed mechanistic studies reveal that crystals of different morphologies and dimensions can be produced by a “bottom-up” hierarchical assembly where structures such as one-dimensional (1-D) nanofibers can be aggregated into higher order architectures. A large variety of crystalline nanostructures, including 1-D nanofibers and nanowires, 2-D nanoribbons and nanosheets, 3-D nanoplates, stacked sheets, nanoflowers, porous networks, hollow spheres, and twisted coils, can be obtained by controlling the nucleation of the crystals and the non-covalent interactions between the doped oligomers. These nanoscale crystals exhibit enhanced conductivity compared to their bulk counterparts as well as interesting structure-property relationships such as shape-dependent crystallinity. Furthermore, the morphology and dimension of these structures can be largely rationalized and predicted by monitoring molecule-solvent interactions via absorption studies. Using doped tetra-aniline as a model system, the results and strategies presented in this article provide insight into the general scheme of shape and size control for organic materials.

[0011] There is a known energy storage device based on a multilayer structure. The energy storage device includes first and second electrodes, and a multilayer structure comprising blocking and dielectric layers. The first blocking layer is disposed between the first electrode and a dielectric layer, and the second blocking layer is disposed between the second electrode and a dielectric layer. Dielectric constants of the first and second blocking layers are both independently greater than the dielectric constant of the dielectric layer. Figure 1 shows one exemplary design that includes electrodes 1 and 2, and multilayer structure comprising layers made of dielectric material (3, 4, 5) which are separated by layers of blocking material (6, 7, 8, 9). The blocking layers 6 and 9 are disposed in the neighborhood of the electrodes 1 and 2 accordingly and characterized by higher dielectric constant than dielectric constant of the dielectric material. A drawback of this device is that blocking layers of high dielectric permittivity located directly in contact with electrodes can lead to destruction of the energy storage device. Materials with high dielectric permittivity which are based on composite materials and containing polarized particles (such as PANI particles) might demonstrate a percolation phenomenon. The formed polycrystalline structure of layers has multiple tangling chemical bonds on borders between crystallites. When the used material with high dielectric

permittivity possesses polycrystalline structure a percolation might occur along the borders of crystal grains. Another drawback of the known device is an expensive manufacturing procedure which is vacuum deposition of all layers.

[0012] Capacitors as energy storage device have well-known advantages versus electrochemical energy storage, e.g. a battery. Compared to batteries, capacitors are able to store energy with very high power density, i.e. charge/recharge rates, have long shelf life with little degradation, and can be charged and discharged (cycled) hundreds of thousands or millions of times.

However, capacitors often do not store energy in small volume or weight as in case of a battery, or at low energy storage cost, which makes capacitors impractical for some applications, for example electric vehicles. Accordingly, it would be an advance in energy storage technology to provide capacitors of higher volumetric and mass energy storage density and lower cost.

[0013] The present invention solves a problem of the further increase of volumetric and mass density of reserved energy of the energy storage device, and at the same time reduces cost of materials and manufacturing process.

SUMMARY OF THE INVENTION

[0014] The present invention provides an energy storage device comprising a first electrode, a second electrode, and a solid multilayer structure disposed between said first and second electrodes. Said electrodes are flat and planar and positioned parallel to each other, and said solid multilayer structure comprises m homogeneous insulating and conductive layers. Said layers are disposed parallel to said electrodes, and said layers has following sequence: A-B-(A-B-...A-B-)A, where A is an insulating layer which comprises an insulating dielectric material, B is a conductive layer, and number of layers m is equal or more than 3.

[0015] In a yet further aspect, the present invention provides a method of producing an energy storage device, which comprises the steps of (a) preparation of a conducting substrate serving as one of the electrodes, (b) formation of a solid multilayer structure, and (c) formation of the second electrode on the multilayer structure, wherein formation of the multilayer structure comprises alternating steps of the application of insulating and conductive layers or a step of coextrusion of layers.

BRIEF DESCRIPTION OF THE DRAWINGS

[0016] Figure 1 is a schematic illustration that shows an energy storage device.

[0017] Figure 2 is a schematic illustration that shows an energy storage device according to an embodiment of the invention.

[0018] Figure 3 is a schematic illustration that shows an energy storage device according to another embodiment of the invention.

DETAILED DESCRIPTION OF THE INVENTION

[0019] The general description of the embodiments of the present invention having been made, a further understanding can be obtained by reference to the specific preferred embodiments, which are given herein only for the purpose of illustration and are not intended to limit the scope of the appended claims.

[0020] An energy storage device is disclosed herein. Depending on the application, dielectric permittivity of the insulating dielectric material ϵ_{ins} may be in the broad range; for most applications it will be in the range between about 2 and 25. The insulating layer comprises a material characterized by a band gap of greater than 4 eV and by breakdown field strength in the range between about of 0.01 V/nm and greater than 2.5 V/nm. Due to high polarizability, the conductive material possesses relatively high dielectric permittivity ϵ_{cond} in comparison with dielectric permittivity of the insulating dielectric material. Thus, the layer comprising the conductive material possesses dielectric permittivity ϵ_{cond} , which 10 – 100,000 times greater than dielectric permittivity ϵ_{ins} of the material of the insulating layer. Therefore the electric field intensity of the insulating layer E_{ins} and electric field intensity of the conductive layer E_{cond} satisfy the following ratio: $E_{\text{cond}} = (\epsilon_{\text{ins}} / \epsilon_{\text{cond}}) \cdot E_{\text{ins}}$. Therefore electric field intensity E_{cond} is much smaller than electric field intensity E_{ins} . Therefore in order to increase a working voltage of the energy storage device it is required to increase number of the insulating layers.

[0021] Capacitor of the energy storage device according to the present invention is determined by the following expression:

$$C = [d_{\text{ins}} \cdot n_{\text{ins}} / (\epsilon_0 \epsilon_{\text{ins}} S) + d_{\text{cond}} \cdot (n_{\text{ins}} - 1) / (\epsilon_0 \epsilon_{\text{cond}} \cdot S)]^{-1} = \\ = \epsilon_0 \cdot S \cdot [d_{\text{ins}} \cdot n_{\text{ins}} / \epsilon_{\text{ins}} + d_{\text{cond}} \cdot (n_{\text{ins}} - 1) / \epsilon_{\text{cond}}]^{-1}, \quad (3)$$

where d_{ins} is thickness of the insulating layer, d_{cond} is thickness of the conductive layer, n_{ins} is number of the insulating layers, ϵ_0 is dielectric permittivity of vacuum.

[0022] According to the formula (3), value of the capacitor of the energy storage device is determined by the layers with high dielectric permittivity if the following inequality is carried out:

$$d_{\text{cond}} \gg (n_{\text{ins}} / (n_{\text{ins}} - 1)) \cdot (\epsilon_{\text{cond}} / \epsilon_{\text{ins}}) \cdot d_{\text{ins}} \text{ or} \\ d_{\text{cond}} = p \cdot (n_{\text{ins}} / (n_{\text{ins}} - 1)) \cdot (\epsilon_{\text{cond}} / \epsilon_{\text{ins}}) \cdot d_{\text{ins}}, \text{ where } p \geq 3, \quad (4)$$

$$\text{if } n_{\text{ins}} \gg 1 \text{ then } d_{\text{cond}} = p \cdot (\epsilon_{\text{cond}} / \epsilon_{\text{ins}}) \cdot d_{\text{ins}}, \quad (5)$$

[0023] Thus, insulating layers provide a high breakdown voltage of the capacitor, and conductive layers provide high dielectric permittivity of the multilayered structure.

[0024] In some embodiments of the invention, the solid insulating dielectric layers may possess a different structure in the range between an amorphous and crystalline solid layer, depending on the material and manufacturing procedure used.

[0025] In one embodiment of the disclosed energy storage device, the insulating layers comprise modified organic compounds of the general structural formula I:



where Cor is a polycyclic organic compound with conjugated π -system, M are modifying functional groups; and n is the number of the modifying functional groups, where $n \geq 1$. In one embodiment of the present invention, the polycyclic organic compound is selected from the list comprising oligophenyl, imidazole, pyrazole, acenaphthene, triazine, indanthrone and having a general structural formula selected from structures 1–43 as given in Table 1.

Table 1. Examples of polycyclic organic compounds for the insulating layers

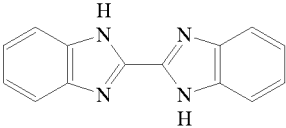
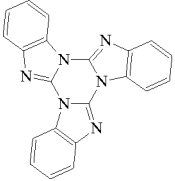
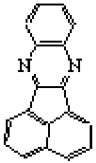
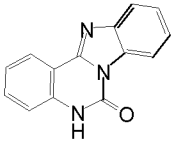
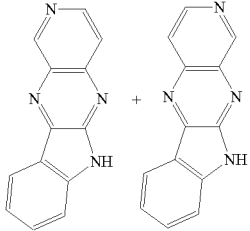
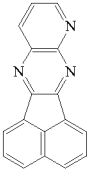
	1
	2
	3
	4
	5
	6

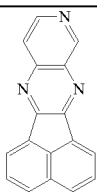
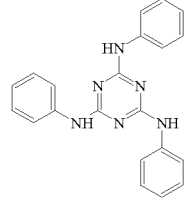
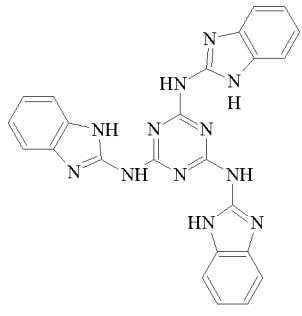
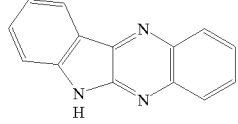
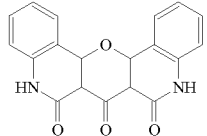
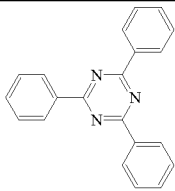
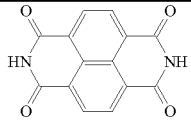
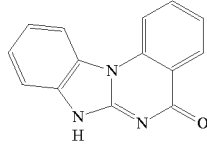
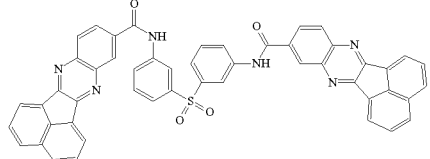
	<p>7</p>
	<p>8</p>
	<p>9</p>
	<p>10</p>
	<p>11</p>
	<p>12</p>
	<p>13</p>
	<p>14</p>
	<p>15</p>

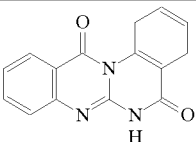
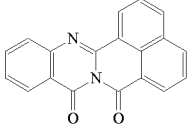
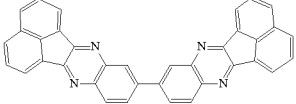
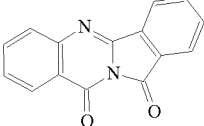
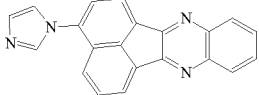
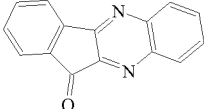
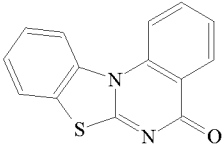
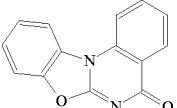
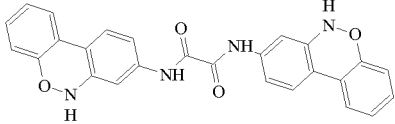
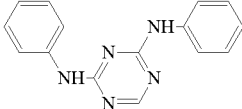
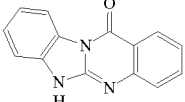
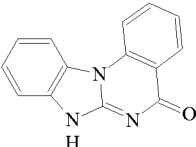
	<p>16</p>
	<p>17</p>
	<p>18</p>
	<p>19</p>
	<p>20</p>
	<p>21</p>
	<p>22</p>
	<p>23</p>
	<p>24</p>
	<p>25</p>
	<p>26</p>
	<p>27</p>

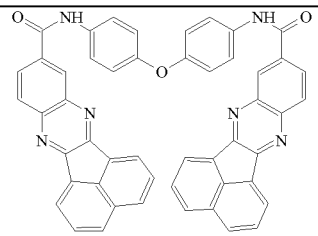
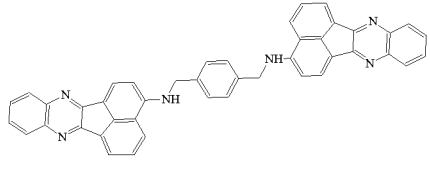
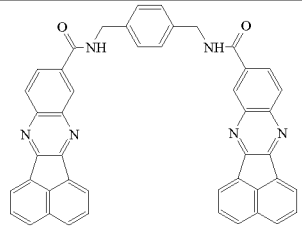
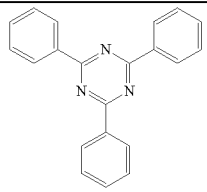
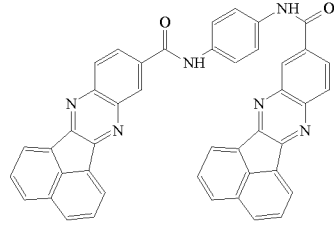
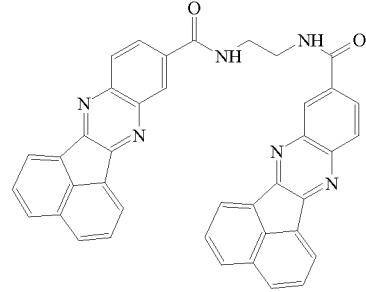
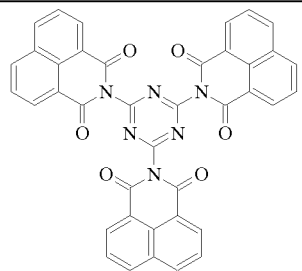
	<p>28</p>
	<p>29</p>
	<p>30</p>
	<p>31</p>
	<p>32</p>
	<p>33</p>
	<p>34</p>

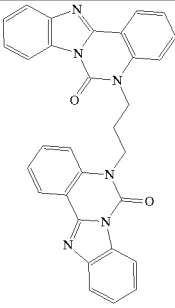
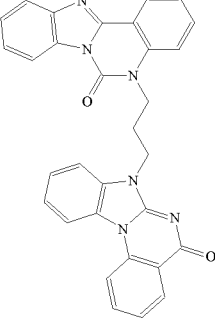
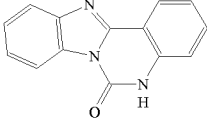
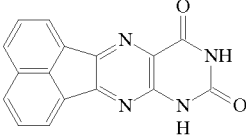
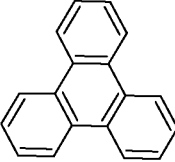
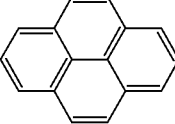
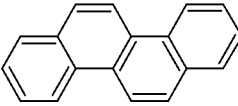
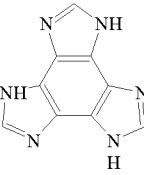
	<p>35</p>
	<p>36</p>
	<p>37</p>
	<p>38</p>
	<p>39</p>
	<p>40</p>
	<p>41</p>
	<p>41</p>

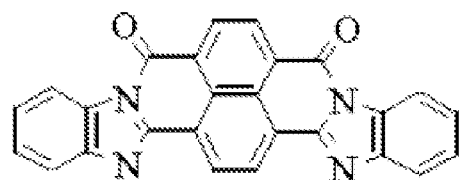
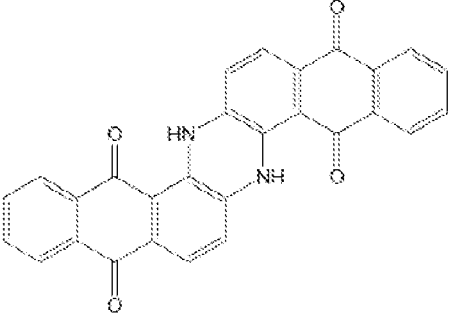
	42
	43

[0026] In another embodiment of the present invention, the modifying functional groups are selected from the list comprising alkyl, aryl, substituted alkyl, substituted aryl, and any combination thereof. The modifying functional groups provide solubility of organic compounds at the stage of manufacturing and additional insulating properties to the solid insulating layer of the capacitor. In yet another embodiment of the present invention, the insulating layers comprise polymeric materials selected from the list comprising fluorinated alkyls, polyethylene, poly(vinylidene fluoride-hexafluoropropylene), polypropylene, fluorinated polypropylene, polydimethylsiloxane. In still another embodiment of the present invention, the insulating layers comprise a polymeric material formed on the basis of polymers which are selected from the structures 44 to 49 as given in Table 2.

Table 2. Examples of polymers for the insulating layers

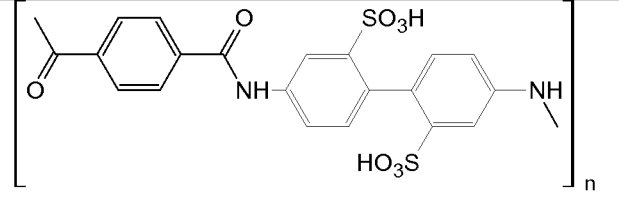
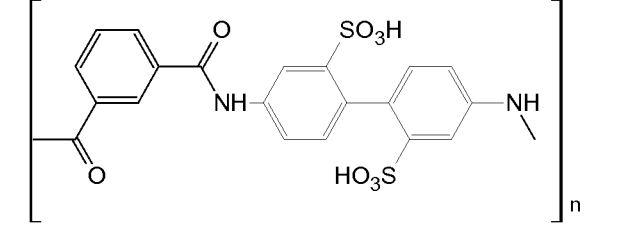
 <p>poly(2,2'-disulfo-4,4'-benzidine terephthalamide)</p>	44
 <p>poly(2,2'-disulfo-4,4'-benzidine isophthalamide)</p>	45

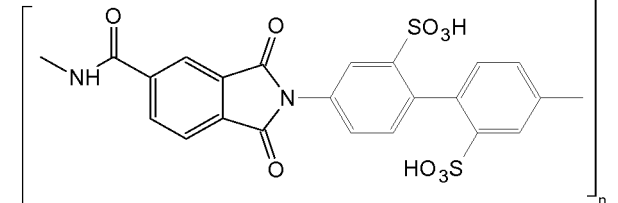
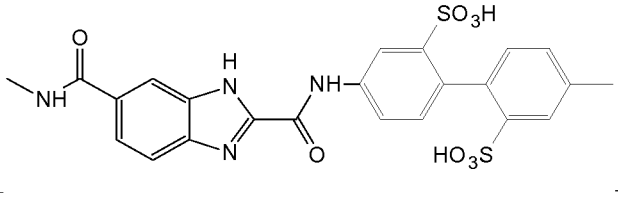
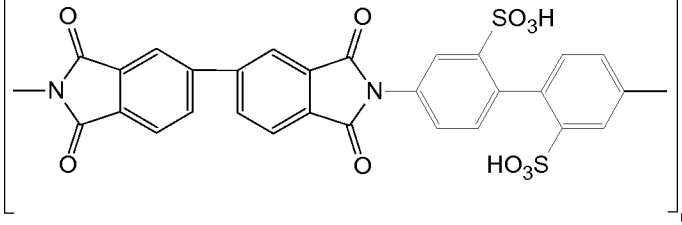
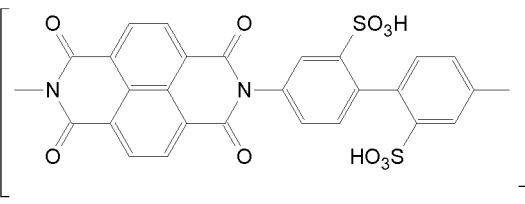
 <p>poly(2,2'-disulfo-4,4'-benzidine 1,3-dioxo-isoindoline-5-carboxamide)</p>	46
 <p>poly(2,2'-disulfo-4,4'-benzidine 1H-benzimidazole-2,5-dicarboxamide)</p>	47
 <p>poly(2,2'-disulfo-4,4'-benzidine 3,3',4,4'-biphenyl tetracarboxylic acid diimide)</p>	48
 <p>poly(2,2'-disulpho-4,4'-benzidine 1,4,5,8-naphtalen tetracarboxylic acid diimide)</p>	49

[0027] The listed materials intended for the insulating layers provide a high intensity of an electric field which is not less than 0.1 Volt per nanometer.

[0028] A wide variety of conducting and semiconducting (conjugated) polymers can be used as conductive layers of the present invention. This variety of polymers have a unique set of properties, combining the electronic properties of metals and semiconductors with the processing advantages and mechanical properties of polymers, see A.J. Heeger, et al., "Semiconducting and Metallic Polymers.", Oxford Graduate Texts, Oxford Press, 2010.

[0029] For the disclosed energy storage device the solid conductive layer may possess a different structure in the range between an amorphous and crystalline solid layer, depending on the material and manufacturing procedure used.

[0030] In one embodiment of the present invention the conductive layer is crystalline.

[0031] In another embodiment of the present invention, the conductive layer comprises material possessing molecular conductivity. A conductive material possessing molecular conductivity refers to a material containing organic molecules wherein electric charges are moved under

action of an external electric field within the limits of these molecules. As a result of displacement of mobile charges inside of this molecule, an electric dipole oriented along the electric field is formed (Jean-Pierre Farges, Organic Conductors, Fundamentals and applications, Marcell-Dekker Inc. NY. 1994).

[0032] In one embodiment of the present invention, the conductive layers comprise electroconductive oligomers. In another embodiment of the present invention, the longitudinal axes of the electroconductive oligomers are directed predominantly perpendicularly in relation to the electrode surface. In yet another embodiment of the present invention, the longitudinal axes of the electroconductive oligomers are directed predominantly parallel in relation to the electrode surface.

[0033] In still another embodiment of the present invention, the conductive layer comprising the electroconductive oligomers predominantly possesses lateral translational symmetry. Translational symmetry of the object means that a shift on a certain vector does not change the object.

[0034] In one embodiment of the present invention, the electroconductive oligomers are selected from the list comprising following structural formulas corresponding to one of structures 50 to 56 as given in Table 3.

Table 3. Examples of polymers for the conductive layers

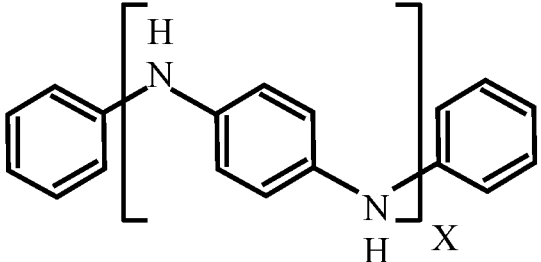
	50
---	----

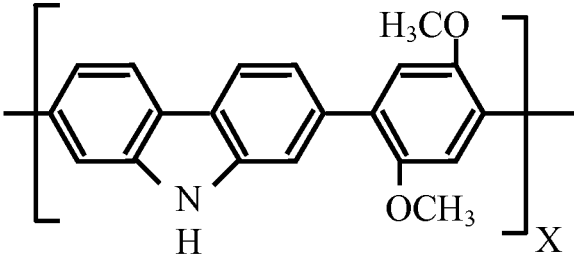
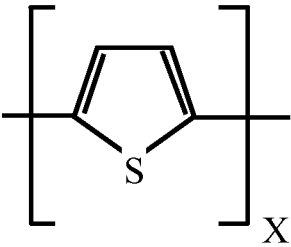
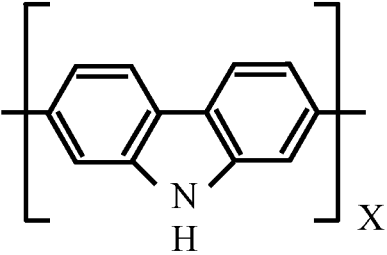
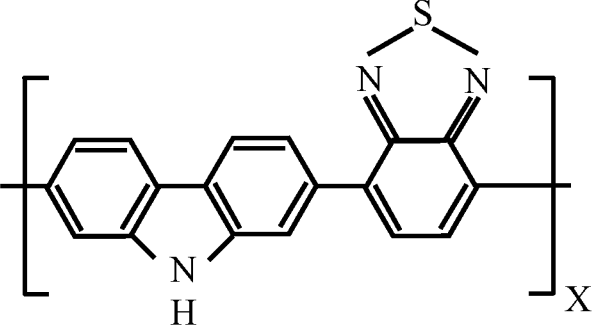
	<p>51</p>
	<p>52</p>
	<p>53</p>
	<p>54</p>

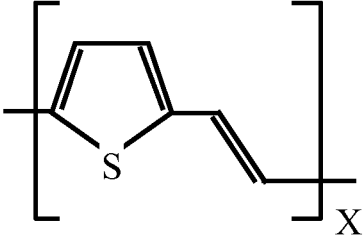
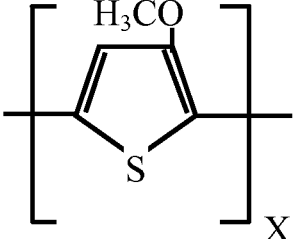
	55
	56

where X = 2, 3, 4, 5, 6, 7, 8, 9, 10, 11 or 12

[0035] In another embodiment of the energy storage device of the present invention, the conductive layer comprises low-molecular weight electroconductive polymers. In another embodiment of the present invention, the low-molecular weight electroconductive polymer contains monomers selected from the structures 50 to 56 as given in Table 3. In another embodiment of the disclosed energy storage device, the electroconductive oligomers further comprise substitute groups and are described by the following general structural formula II:



where R_q is a set of substitute groups, q is a number of the substitute groups R in the set R_q , and $q = 1, 2, 3, 4, 5, 6, 7, 8, 9, \text{ or } 10$. In yet another embodiment of the present invention, the substituents R are independently selected from the list comprising alkyl, aryl, substituted alkyl, substituted aryl, and any combination thereof

[0036] In still another embodiment of the present invention, thickness of the insulating layer (d_{ins}), thickness of the conductive layer (d_{cond}), number of the insulating layers ($n_{\text{ins}} \geq 2$), dielectric permittivity of the insulating dielectric material (ϵ_{ins}) and dielectric permittivity of the conductive layer (ϵ_{cond}) satisfy the following relation:

$$d_{\text{cond}} = p \cdot (n_{\text{ins}} / (n_{\text{ins}} - 1)) \cdot (\epsilon_{\text{cond}} / \epsilon_{\text{ins}}) \cdot d_{\text{ins}}, \text{ where } p \geq 3. \quad (6)$$

[0037] Electrodes of the disclosed energy storage device may be made of any suitable material, including but not limited to Pt, Cu, Al, Ag or Au.

[0038] The disclosed energy storage device can be produced by a variety of manufacturing methods, which in general comprise the steps of a) preparation of a conducting substrate serving

as one of the electrodes, b) formation of a multilayer structure, and c) formation of the second electrode on the multilayer structure. Formation of the multilayer structure comprises either alternating steps of the application of insulating and conductive layers or a step of coextrusion of layers.

[0039] In one embodiment of the present invention the alternating steps of the multilayer structure formation comprise successive alternating applications of solutions of liquid insulating and conductive layers, wherein each application is followed with a step of drying to form a solid insulating and conductive layers. Depending on the required design of the energy storage device, in particular on the number of layers in the multilayer structure, the alternating application steps are recurred until a formation of the multilayer structure is completed. In this embodiment the insulating layer is formed as the first and the last layer of the multilayer structure, being in direct contact with the electrodes.

[0040] In one embodiment of the present invention the alternating steps of the multilayer structure formation comprise successive alternating applications of melts of insulating and conductive layers, wherein each application is followed with a step of cooling down to form a solid insulating and conductive layers. Depending on the required design of the energy storage device, in particular on the number of layers in the multilayer structure, the alternating application steps are recurred until a formation of the multilayer structure is completed. In this embodiment the insulating layer is formed as the first and the last layer of the multilayer structure, being in direct contact with the electrodes.

[0041] In another embodiment of the present invention a step of coextrusion of layers comprises a step of coextrusion of set of liquid layers successively containing alternating conductive materials and insulating dielectric materials onto the substrate, and followed by drying to form the solid multilayer structure.

[0042] In another embodiment of the present invention a step of coextrusion of layers comprises a step of coextrusion of set of layers successively containing alternating melts of conductive materials and insulating dielectric materials onto the substrate, and followed by drying to form the solid multilayer structure.

[0043] Depending on the design of the energy storage device, in particular on the number of layers in the multilayer structure, the extrusion may be completed in one step or recurred until a formation of the multilayer structure is completed. The insulating layer is formed in direct contact with the electrodes.

[0044] In order that the invention may be more readily understood, reference is made to the following examples, which is intended to be illustrative of the invention, but is not intended to be limiting in scope.

Example 1

[0045] Example 1 describes an energy storage device comprising a solid multilayer structure of two insulating and one conductive layer.

[0046] The design of the energy storage device is shown in Figure 2 and includes electrodes 10 and 11 and a solid multilayer structure comprising two layers of an insulating dielectric material (13 and 14) separated with one layer made of a conductive material (12). Polyaniline (PANI) was used as a conductive material, and polyethylene was used as an insulating dielectric material. Thickness of the insulating layer was $d_{\text{ins}}=25$ nm. Electrodes 10 and 11 were made of copper. Dielectric permittivity of polyethylene is equal to 2.2 (i.e. $\epsilon_{\text{ins}}=2.2$). Breakdown voltage is $V_{\text{bd}} = 40$ kilovolt on thickness of 1 millimeter (0.04 v/nm); thus, a polyethylene film of 25-nm thickness had a breakdown voltage equal to 1 volt. Therefore a working voltage of the capacitor did not exceed the breakdown voltage V_{bd} of two insulating layers with thickness 25 nm each which is approximately equal to 2 V. The conductive polymer material (polyaniline (PANI)) had dielectric permittivity ϵ_{cond} equal to 1000 and thickness of $d_{\text{cond}} = 50$ μm .

Example 2

[0047] Example 2 describes an energy storage device comprising a solid multilayer structure of alternating insulating and conductive layers.

[0048] The design of the energy storage device is shown in Figure 3 and includes electrodes 15 and 16 and a solid multilayer structure comprising alternating layers of insulating and conductive materials, wherein layers of an insulating dielectric material (20, 21, 22, 23) were separated by layers made of a conductive material (17, 18, 19). Polyaniline (PANI) was used as a conductive material and polyethylene was used as an insulating dielectric material. Thickness of the insulating layer was $d_{\text{ins}}=25$ nm. Electrodes 15 and 16 were made of copper. Dielectric permittivity of polyethylene is equal to 2.2 (i.e. $\epsilon_{\text{ins}}=2.2$) and breakdown voltage is $V_{\text{bd}} = 40$ kilovolt on thickness of 1 millimeter. Thus, a polyethylene film of 25-nm thickness has a breakdown voltage equal to 1 volt. Therefore the working voltage of the capacitor did not exceed breakdown voltage V_{bd} which was approximately equal to 4 V. The conductive polymer material possessing (polyaniline (PANI)) had dielectric permittivity ϵ_{cond} equal to 1000. In this example thickness of the layer comprising a conductive material was selected as $d_{\text{cond}} = 50$ μm .

Example 3

[0049] Example 3 describes calculation of number and thickness of insulating layers depending on value of working voltage of the capacitor. For manufacturing of energy storage device with a working voltage of 100 volt a number of 25-nm thick the insulating layers shall be increased

and/or thickness of layers needs to be higher in order to create total thickness of insulating material about 2500 nm. For industrial applications manufacturing of the energy storage device with polyethylene used as an insulating layer with 25-nm thickness of each layer, a desired working voltage will require more than 100 layers. This estimation is based on a breakdown voltage of $V_{bd} = 40$ kilovolt on thickness of 1 millimeter. Dielectric permittivity of a conductive material in this example is equal to one hundred thousand (100,000). Thickness of each conductive layer is approximately equal to 300 microns. At increasing of target working voltage up to 1000 volt, a required number of the insulating layers and their thickness is increased up to the $D=N*d = 25000$ nm where D is total thickness of all layers, N- is number of layers, and d – is thickness of each layer.

[0050] Although the present invention has been described in detail with reference to a particular preferred embodiment, persons possessing ordinary skill in the art to which this invention pertains will appreciate that various modifications and enhancements may be made without departing from the spirit and scope of the claims that follow.



CLAIMS

What is claimed is:

1. An energy storage device comprising
 - a first electrode,
 - a second electrode, and
 - a solid multilayer structure disposed between said first and second electrodes,
 wherein said electrodes are flat and planar and positioned parallel to each other, and
 - wherein said solid multilayer structure comprises m insulating and conductive layers,
 - said layers are disposed parallel to said electrodes, and
 - said layers have the following sequence: A-B-(A-B-...A-B-)A, where
 - A is a homogeneous insulating layer which comprises an insulating dielectric material,
 - B is a homogeneous conductive layer, and
 - m is equal to 3 or more.
2. An energy storage device according to Claim 1, wherein said insulating layers are crystalline.
3. An energy storage device according to Claim 1, wherein said insulating layers comprise modified organic compounds of the general structural formula I:

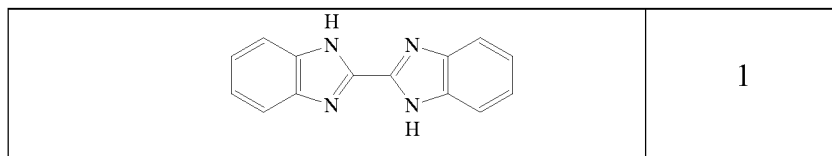
$$\{\text{Cor}\}(M)_n, \quad (\text{I})$$
 where Cor is a polycyclic organic compound with conjugated π -system, M are modifying functional groups; and n is the number of the modifying functional groups, where n is equal to 1 or more.
4. An energy storage device according to Claim 3, wherein the polycyclic organic compound is selected from the group consisting of oligophenyl, imidazole, pyrazole, acenaphthene, triazine, and indanthrone, and the polycyclic organic compound has a general structural formula selected from the group consisting of structures 1–43 as follows:

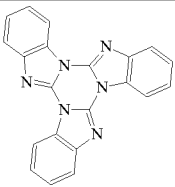

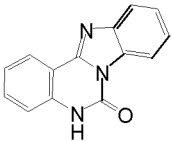
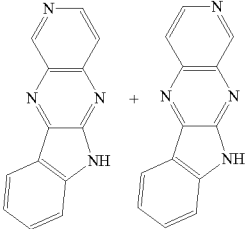
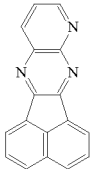
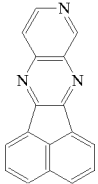
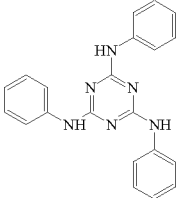
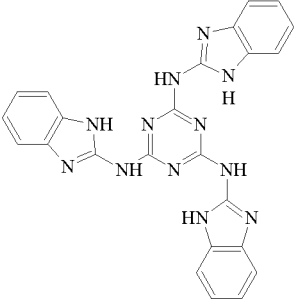
	<p>2</p>
	<p>3</p>
	<p>4</p>
	<p>5</p>
	<p>6</p>
	<p>7</p>
	<p>8</p>
	<p>9</p>

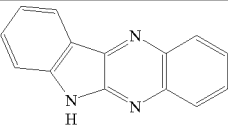
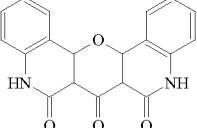
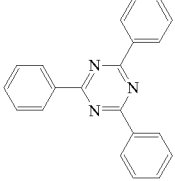
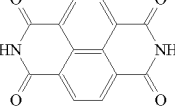
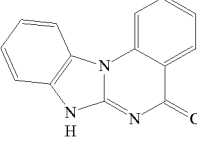
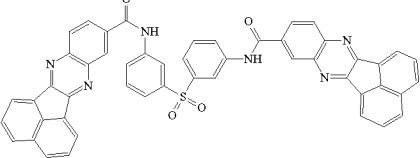
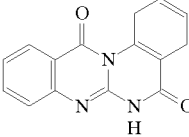
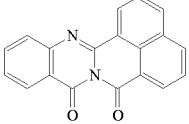
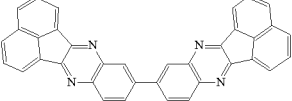
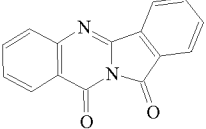
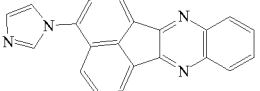
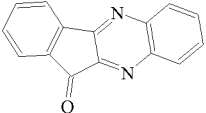
	<p>10</p>
	<p>11</p>
	<p>12</p>
	<p>13</p>
	<p>14</p>
	<p>15</p>
	<p>16</p>
	<p>17</p>
	<p>18</p>
	<p>19</p>
	<p>20</p>
	<p>21</p>

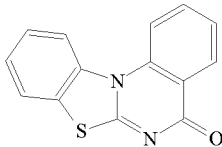
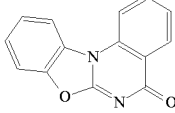
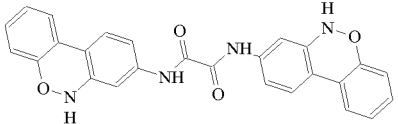
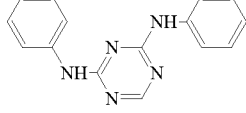
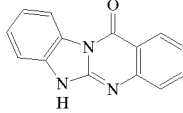
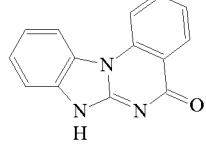
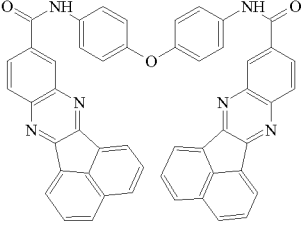
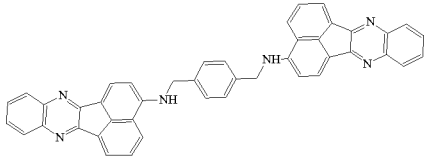
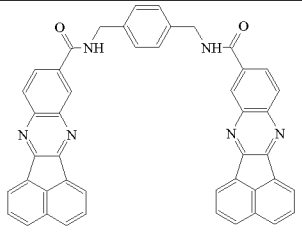
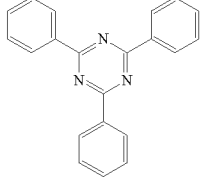
	<p>22</p>
	<p>23</p>
	<p>24</p>
	<p>25</p>
	<p>26</p>
	<p>27</p>
	<p>28</p>
	<p>29</p>
	<p>30</p>
	<p>31</p>

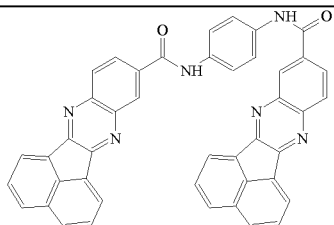
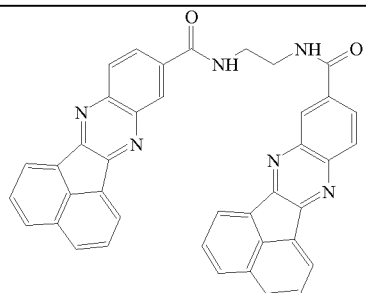
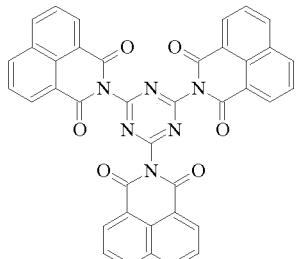
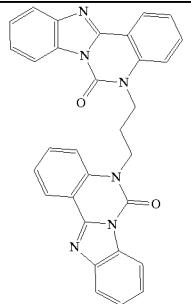
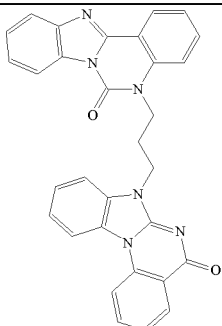
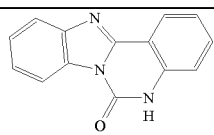
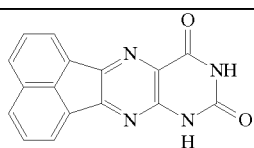
	<p>32</p>
	<p>33</p>
	<p>34</p>
	<p>35</p>
	<p>36</p>
	<p>37</p>
	<p>38</p>

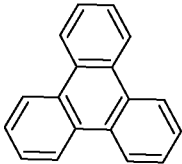
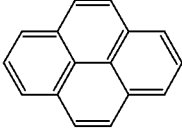
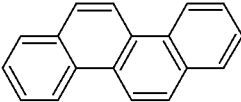
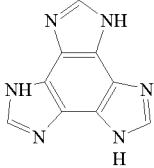
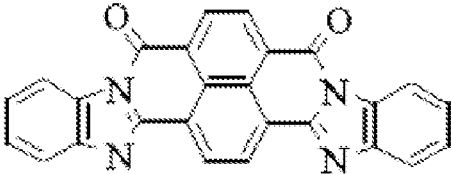
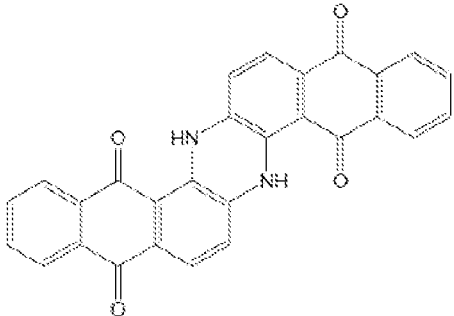
	39
	40
	41
	41
	42
	43

5. An energy storage device according to Claim 3, wherein the modifying functional groups are selected from the group consisting of alkyl, aryl, substituted alkyl, substituted aryl, and any combination thereof.

6. An energy storage device according to Claim 1, wherein said insulating layers comprise polymeric materials selected from the group consisting of fluorinated alkyls, polyethylene, kevlar, poly(vinylidene fluoride-hexafluoropropylene), polypropylene, fluorinated polypropylene, polydimethylsiloxane.

7. An energy storage device according to Claim 1, wherein the insulating layers comprise a polymeric material formed with units selected from structures 44 to 49 as follows:

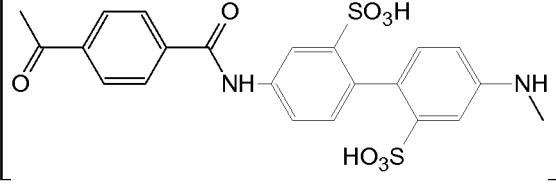
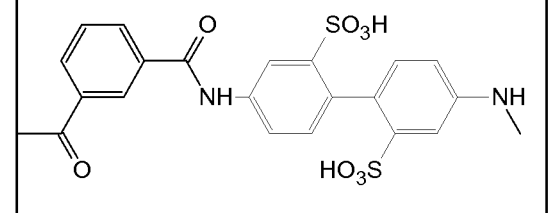
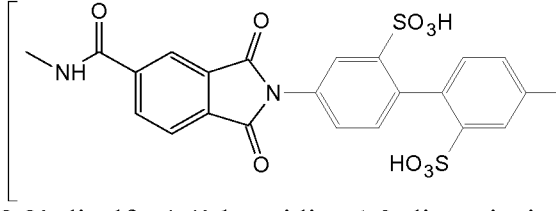
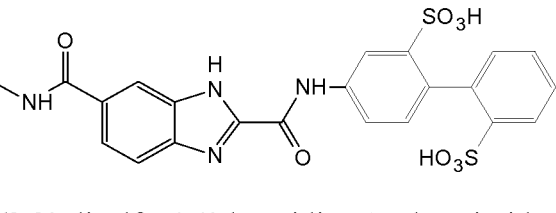
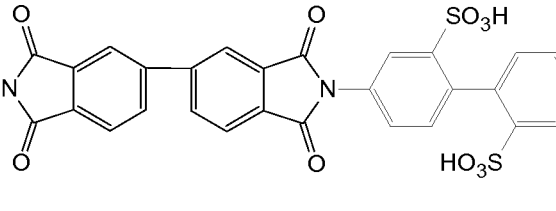
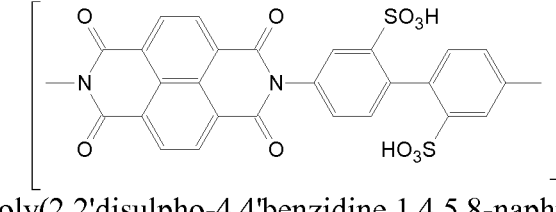
 <p>poly(2,2'-disulfo-4,4'-benzidine terephthalamide)</p>	44
 <p>poly(2,2'-disulfo-4,4'-benzidine isophthalamide)</p>	45
 <p>poly(2,2'-disulfo-4,4'-benzidine 1,3-dioxo-isindoline-5-carboxamide)</p>	46
 <p>poly(2,2'-disulfo-4,4'-benzidine 1H-benzimidazole-2,5-dicarboxamide)</p>	47
 <p>poly(2,2'-disulfo-4,4'-benzidine 3,3',4,4'-biphenyl tetracarboxylic acid diimide)</p>	48
 <p>poly(2,2'-disulfo-4,4'-benzidine 1,4,5,8-naphthalen tetracarboxylic acid diimide)</p>	49

8. An energy storage device according to Claim 1, wherein the conductive layers are crystalline.

9. An energy storage device according to Claim 1, wherein the conductive layers comprise material possessing molecular conductivity.

10. An energy storage device according to Claim 1, wherein said conductive layers comprise electroconductive oligomers.

11. An energy storage device according to Claim 10, wherein longitudinal axes of the electroconductive oligomers are directed predominantly perpendicularly to the electrodes.

12. An energy storage device according to Claim 10, wherein longitudinal axes of the electroconductive oligomers are directed predominantly parallel to the electrodes.

13. An energy storage device according to Claim 10, wherein the electroconductive oligomers predominantly possess lateral translational symmetry.

14. An energy storage device according to Claim 10, wherein the electroconductive oligomers are selected from the group consisting of structures 50 to 56 as follows:

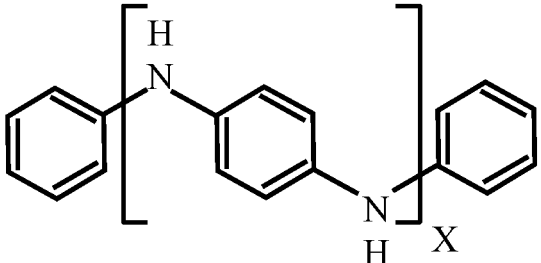
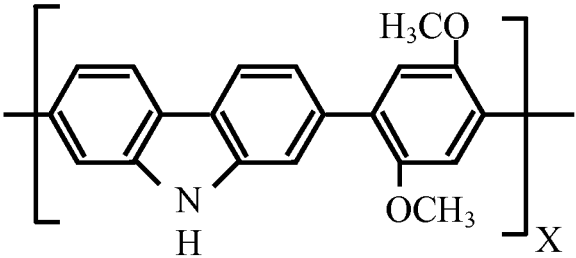
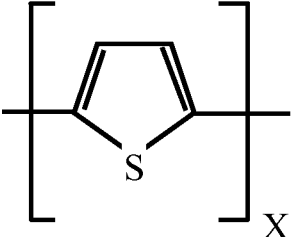
	50
	51
	52

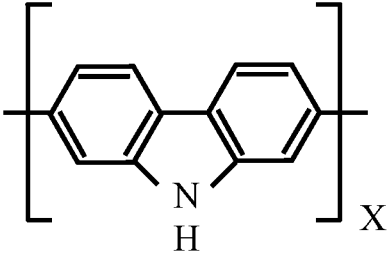
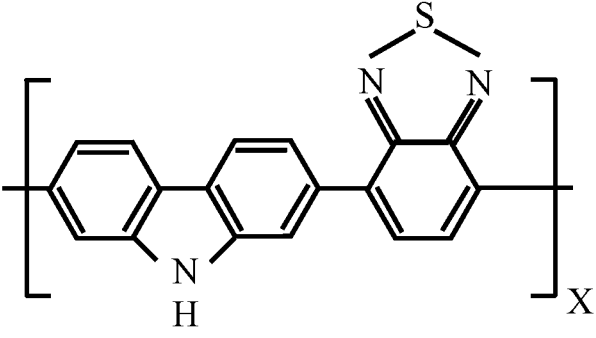
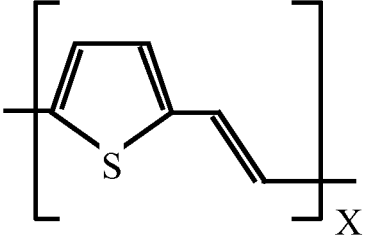
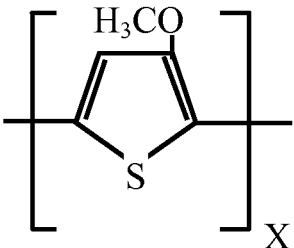
	53
	54
	55
	56

where X = 2, 3, 4, 5, 6, 7, 8, 9, 10, 11 or 12

15. An energy storage device according to Claim 1, wherein said conductive layers comprise low-molecular weight electroconductive polymers.

16. An energy storage device according to Claim 15, wherein the low-molecular weight electroconductive polymers have monomers selected from the group consisting of structures 50 to 56 as follows:

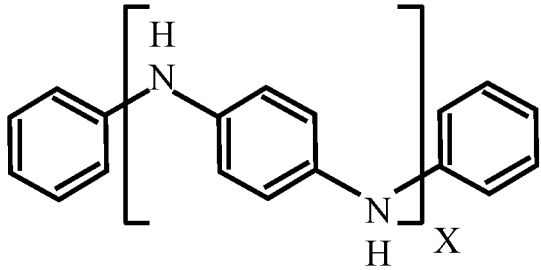
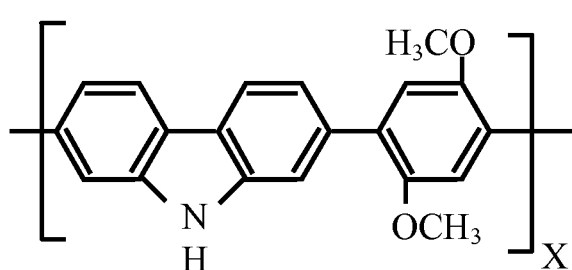
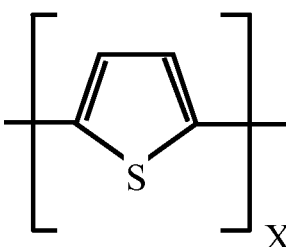
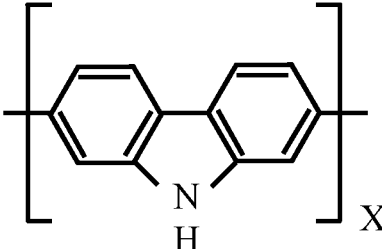
	<p>50</p>
	<p>51</p>
	<p>52</p>
	<p>53</p>

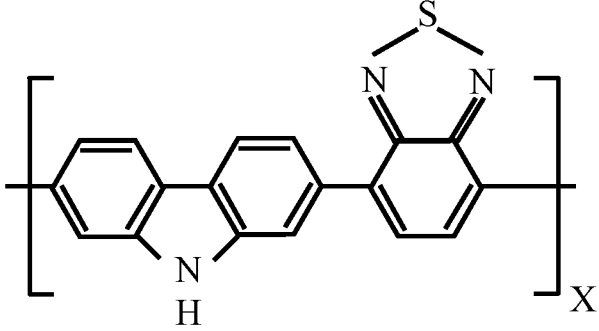
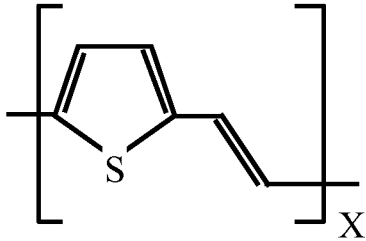
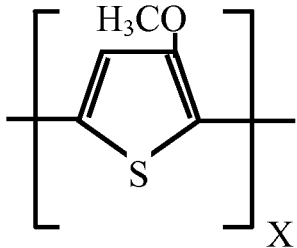
	54
	55
	56

where X = 2, 3, 4, 5, 6, 7, 8, 9, 10, 11 or 12

17. An energy storage device according to Claim 10, wherein the electroconductive oligomers further comprise substitute groups and are described by the following general structural formula II:

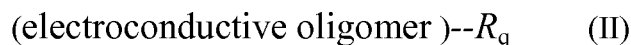

where R_q is a set of substitute groups, and q is a number of the substitute groups R in the set R_q , q equals to 1, 2, 3, 4, 5, 6, 7, 8, 9 or 10.

18. An energy storage device according to Claim 17, wherein the substitute groups R are independently selected from the group consisting of alkyl, aryl, substituted alkyl, substituted aryl, and any combination thereof.

19. An energy storage device according to Claim 1, wherein insulating layer thickness (d_{ins}), conductive layer thickness (d_{cond}), number of the insulating layers ($n_{\text{ins}} \geq 2$),

dielectric permittivity of the insulating dielectric material (ϵ_{ins}) and dielectric permittivity of the conductive layer (ϵ_{cond}) satisfy the following relation:

$$d_{\text{cond}} = p \cdot (n_{\text{ins}} / (n_{\text{ins}} - 1)) \cdot (\epsilon_{\text{cond}} / \epsilon_{\text{ins}}) \cdot d_{\text{ins}}, \text{ where } p \geq 3$$

20. An energy storage device according to Claim 1, wherein the electrodes comprise Pt, Cu, Al, Ag and/or Au.
21. An energy storage device according to Claim 1, wherein the electrodes comprise copper, m is equal to 3, the insulating dielectric material A comprises polyethylene, the conductive material B comprises polyaniline (PANI), insulating layer thickness is $d_{\text{ins}}=25$ nm, conductive layer thickness $d_{\text{cond}}=50$ μm , and a breakdown voltage V_{bd} is approximately 2 V.
22. An energy storage device according to Claim 1, wherein said electrodes comprise copper, m is equal to 7, the insulating dielectric material comprises polyethylene, the conductive material comprises polyaniline (PANI), insulating layer thickness is $d_{\text{ins}}=25$ nm, conductive layer thickness is $d_{\text{cond}}=50$ μm , and a breakdown voltage V_{bd} is approximately 4 V.
23. A method of producing an energy storage device, which comprises the steps of
- a) preparation of a conducting substrate serving as a first electrode,
 - b) formation of a multilayer structure on the first electrode, and
 - c) formation of a second electrode on the multilayer structure
- wherein formation of the multilayer structure comprises alternating steps of application of insulating layers and application of conductive layers or a step of coextrusion of insulating and conductive layers.
24. A method according to Claim 23, wherein the step b) of formation of the multilayer structure comprises alternating steps of the application of a solution of an insulating material and the application of a solution of the conductive material, wherein both application steps are followed by a step of drying to form solid insulating layers and solid conductive layers, the alternating steps are repeated until formation of the multilayer structure is completed, and the insulating layer is formed as the first layer and as the last layer, said first layer and said last layer each being in direct contact with an electrode.
25. A method according to Claim 23, wherein the step b) of formation of the multilayer structure comprises alternating steps of the application of a melt of an insulating material and the application of a melt of the conductive material, wherein both application steps are followed with a step of cooling down to form a solid insulating layer and a solid conductive layer, the alternating steps are repeated until formation of the multilayer structure is completed, and the insulating layer is formed as the first layer and as the last layer, said first layer and said last layer each being in direct contact with an electrode.

26. A method according to Claim 23, wherein the step b) of formation of the solid multilayer structure comprises a step of coextrusion of a set of alternating conductive material layers and insulating dielectric material layers onto the substrate, followed by drying to form the solid multilayer structure.

27. A method according to Claim 23, wherein the step b) of formation of the solid multilayer structure comprises a step of coextrusion of a set of alternating melted conductive material layers and melted insulating dielectric material layers onto the substrate, followed by the step of cooling down to form the solid multilayer structure.

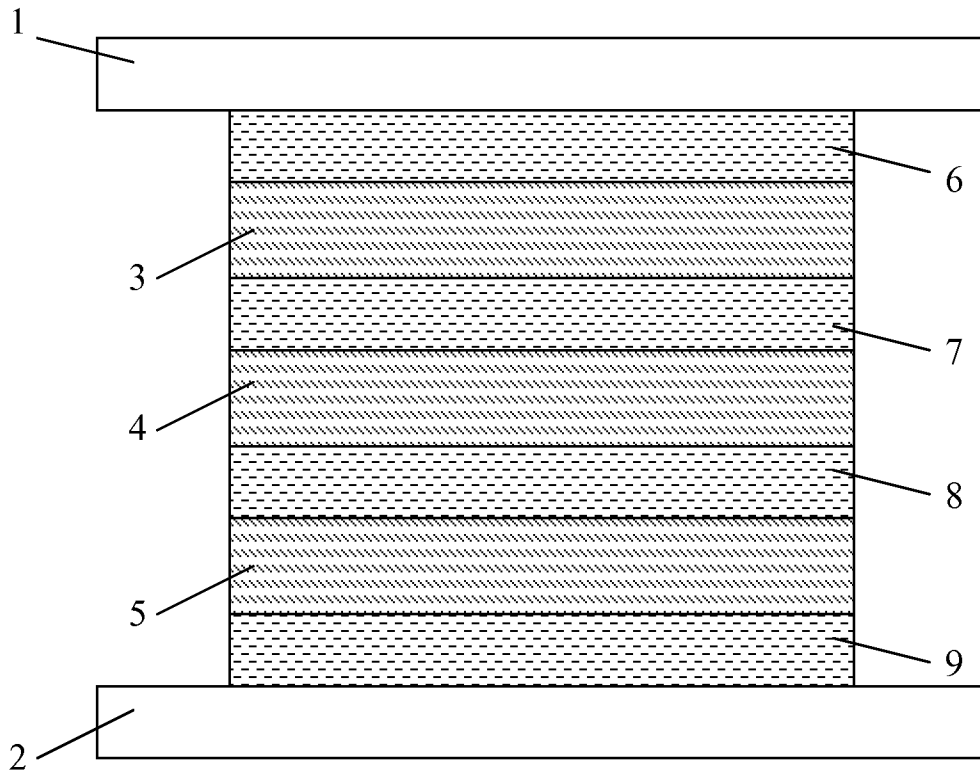

Figure 1 (Prior Art)

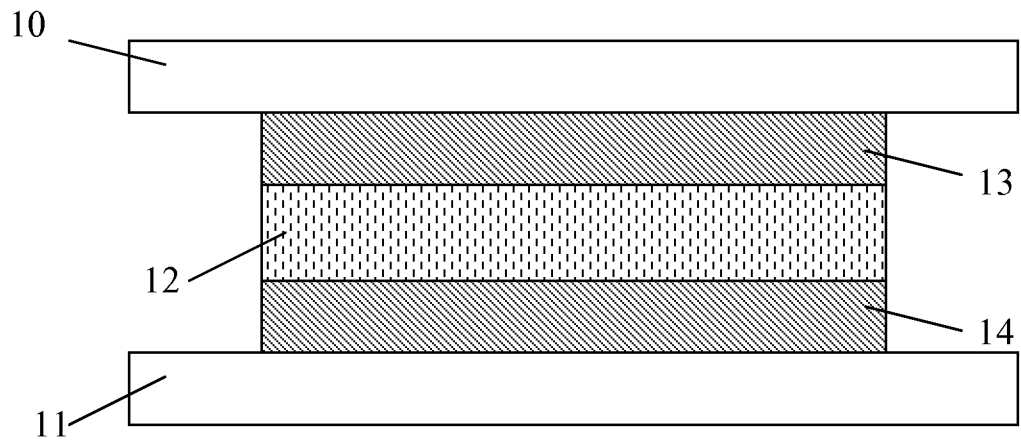

Figure 2

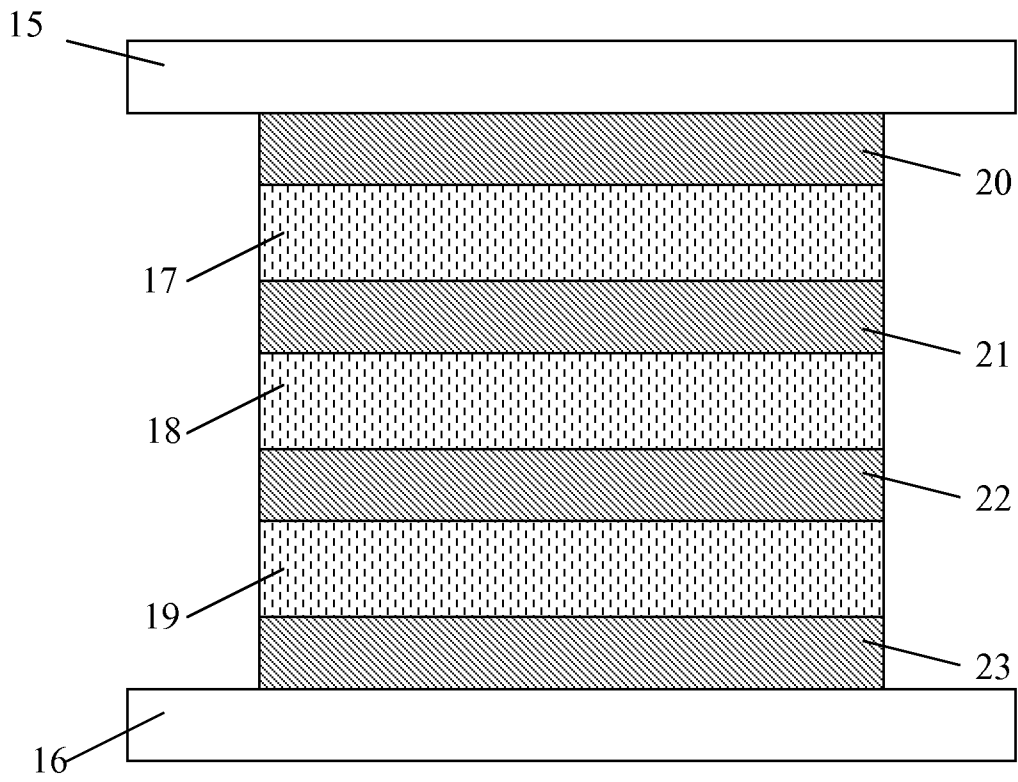

Figure 3