

(19) World Intellectual Property Organization  
International Bureau



(43) International Publication Date  
20 February 2003 (20.02.2003)

PCT

(10) International Publication Number  
**WO 03/015430 A1**

(51) International Patent Classification<sup>7</sup>: **H04Q 7/22**,  
H04M 3/487

[IN/SG]; Rm #119, Extn A Kent Ridge Road, NUS (SG).  
**PRABHAKARA, Kartik** [IN/SG]; Blk 24, Room #03-D,  
NUS, Singapore 118429 (SG).

(21) International Application Number: PCT/SG02/00103

(74) Agent: **GREENE-KELLY, James, Patrick**; Lloyd Wise,  
Tanjong Pagar, P.O. Box 363, Singapore 910816 (SG).

(22) International Filing Date: 23 May 2002 (23.05.2002)

(25) Filing Language: English

(81) Designated States (*national*): AE, AG, AL, AM, AT, AU,  
AZ, BA, BB, BG, BR, BY, BZ, CA, CH, CN, CO, CR, CU,  
CZ, DE, DK, DM, DZ, EC, EE, ES, FI, GB, GD, GE, GH,  
GM, HR, HU, ID, IL, IN, IS, JP, KE, KG, KP, KR, KZ, LC,  
LK, LR, LS, LT, LU, LV, MA, MD, MG, MK, MN, MW,  
MX, MZ, NO, NZ, OM, PH, PL, PT, RO, RU, SD, SE, SG,  
SI, SK, SL, TJ, TM, TN, TR, TT, TZ, UA, UG, US, UZ,  
VN, YU, ZA, ZM, ZW.

(26) Publication Language: English

(30) Priority Data:  
60/310,455 8 August 2001 (08.08.2001) US  
60/324,057 24 September 2001 (24.09.2001) US

(71) Applicant (*for all designated States except US*): **PURPLE  
ACE PTE. LTD.** [SG/SG]; 109, Clementi Road, #07-03  
Kent Vale E, Singapore 129791 (SG).

(84) Designated States (*regional*): ARIPO patent (GH, GM,  
KE, LS, MW, MZ, SD, SL, SZ, TZ, UG, ZM, ZW),  
Eurasian patent (AM, AZ, BY, KG, KZ, MD, RU, TJ, TM),  
European patent (AT, BE, CH, CY, DE, DK, ES, FI, FR,  
GB, GR, IE, IT, LU, MC, NL, PT, SE, TR), OAPI patent  
(BF, BJ, CF, CG, CI, CM, GA, GN, GQ, GW, ML, MR,  
NE, SN, TD, TG).

(72) Inventors; and

(75) Inventors/Applicants (*for US only*): **GARG, Hari, Kr-  
ishna** [US/US]; 109 Clementi Road, #07-03 Kent Vale E,  
Singapore 129791 (SG). **PILLAI, Brojo, Paul, Joseph**

[Continued on next page]

(54) Title: A METHOD OF AND APPARATUS FOR COMMUNICATION OF ADVERTISEMENTS

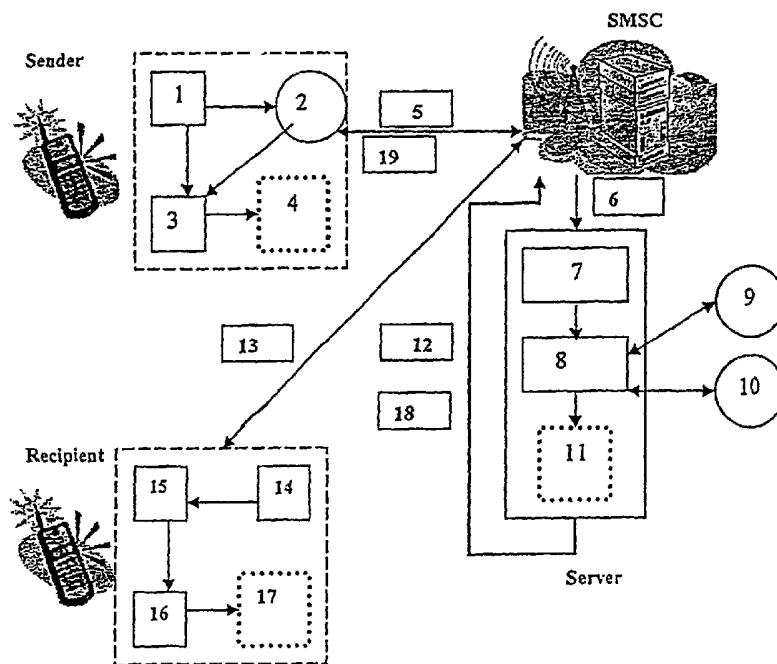

(57) Abstract: A method of and apparatus for including advertising content in a message sent from a sender to a recipient is disclosed in which the sender selects an advertisement to be included with the message and sends the message together with the advertisement or an indication thereof to the recipient. The message may be size-limited with the advertisement reducing the available message size to that remaining within the size limit and the sender composing the message within the available message size. The sender is preferably rewarded in accordance with the advertisements selected.



WO 03/015430 A1



**Declaration under Rule 4.17:**

— *of inventorship (Rule 4.17(iv)) for US only*

**Published:**

— *with international search report*

*For two-letter codes and other abbreviations, refer to the "Guidance Notes on Codes and Abbreviations" appearing at the beginning of each regular issue of the PCT Gazette.*

A METHOD OF AND APPARATUS FOR COMMUNICATION OF  
ADVERTISEMENTS

BACKGROUND AND FIELD OF THE INVENTION

5 This invention relates to a method of and apparatus for communication of advertisements more particularly but not exclusively for use with the short message service (SMS) of the GSM mobile telephone system.

The GSM telephone system provides a text messaging service SMS which allows text  
10 messages up to a length of 100-160 characters to be sent from one mobile telephone to another. SMS has proved to be a very popular communication service. There has been proposed in WO 0122748 a method of appending an advertisement to the end of an SMS message by a service provider to add advertising content to the sent message. The length of the advertisement is determined by the length of the original message, with the  
15 advertisement being fitted in to the remaining space available within the character limitation of the message. It is a disadvantage of this proposal that the advertisement is often constrained by the available space so that the advertisement must either be omitted or adjusted to fit the available space. Furthermore, the user of the mobile telephone has no say in what advertisement is appended by the service provider.

20

It is an object of the invention to provide a communication apparatus and method which alleviates at least one of these disadvantages of the discussed prior art and/or provides the public with a useful choice.

SUMMARY OF THE INVENTION

According to the invention in a first aspect, there is provided a method of including advertising content in a message sent from a sender to a recipient comprising the steps  
5 of the sender selecting an advertisement to be included with the message and sending the message together with the advertisement to the recipient.

In the described embodiment, where the message is size-limited, the advertisement reduces the available message size to that remaining within the size limit and the sender  
10 composes the message within the available message size. The size related message is preferably an SMS message sent to and/or from a GSM mobile telephone. The sender may append the advertisement to the message or the sender may send a tag designating the advertisement to a service provider or other entity which appends the advertisement to the message en route to the recipient. The entity may also select or change the  
15 advertisement sent by the sender in accordance with the nature of the recipient, in particular the ability of the recipient to accept messages of a certain complexity.

In the described embodiment, the advertisement may be selected by the sender from a plurality of available advertisements and these may be provided by means of a menu  
20 available to the sender, for example provided on a mobile telephone of the sender or the user may input an appropriate tag directly. The whole message may be assembled from the message text and the advertisement and split into at least two separate messages if the combined size of the message and advertisement exceeds the size limit, the whole message being reassembled from the separate messages by the recipient. The sender

may append the advertisement to the message or the sender may send a tag designating the advertisement to a service provider or other entity which appends the advertisement to the message and splits the message as appropriate en route to the recipient.

5 According to a second aspect of the invention, there is provided a communication device having a message sending capability and the device having a memory arranged to store an advertisement or an indication thereof, interactive means arranged to allow selection of the advertisement or indication for sending with a said message and means for sending the message to a recipient.

10

In the described embodiment, the message may be of a limited size and preferably processing means is provided which is arranged to limit the available message size to that unoccupied by the advertisement. The communication device may be a mobile telephone having an SMS capability. The advertisement may be directly stored in the  
15 communication device or may be appended en route to the recipient in accordance with the indication.

According to the invention in a third aspect, there is provided a service providing entity comprising a database of advertisements and processing means arranged to receive a  
20 message from a subscriber, attach an advertisement from the database to the message in accordance with a selection by the subscriber and forward the message for delivery to a recipient.

According to the invention in a fourth aspect there is provided a method of providing a communication-related service to a user comprising the steps of providing at least one advertisement to the user, the user being able selectively to append the advertisement to a communication from the user to a recipient, a reward being given to the user if the  
5 selection is made.

In the described embodiment, the reward may be of any form but may be in the form of one which is given by a telecommunication service provider such as a rebate or discount of communication charges or one which is given by the advertiser such as discounts or  
10 loyalty card style points which may be put towards purchases or exchanged for the advertiser's goods or services. The communication is preferably an fixed size message such as an SMS message although this may be any other kind of remote communication for example visually by email or aurally by telephone via the telephone network or otherwise. In the case of an SMS message, the advertisement is appended to the  
15 message, reducing the available message size accordingly.

In the described embodiment, preferably, a track is kept of the advertisements that are sent by the user so that the user may be appropriately rewarded. Such tracking is most preferably performed by a server through which all the messages including the  
20 advertisements are channeled. The user may select to have a given advertisement appended to every message sent by setting a preference in the communication device or may select the advertisement each time a message is sent. Only one message may be selectable or the advertisement may be selectable from a plurality of selectable advertisements.

According to the invention in a fifth aspect there is provided a method of collecting advertising-related data comprising the steps of providing a plurality of advertisements to a plurality of users, each user being able selectively to include a said advertisement  
5 with a communication from the user to a recipient, and determining the number of times each advertisement is sent.

In the described embodiment, preferably, the data is profiled, for example based on age, gender or profession of the users who select the advertisements. Similar determinations  
10 may be made based on the responses of recipients to the advertisements sent.

According to the invention in a sixth aspect, there is provided a method of assembling a size-limited message having character data encoded using first and second character sets, the coding bits per character in the first character set being less than the coding per  
15 character in the second character set comprising the steps of

- (1) identifying any character(s) of the second character set in the message; and
- (2) marking the character(s) of the second character set with a flag to distinguish from the characters of the first character set.

20 Preferably the character sets are ASCII for the first character set and UCS2 for the second character set.

In the described embodiment, this feature allows compression of a Multi-lingual SMS(with different coding schemes -English and other Latin characters are coded in

ASCII(7-bit) and Chinese, Japanese are coded in UCS2(16-bit). This means that when an advertisement in Chinese is appended to an SMS containing English characters, the English characters are not converted to UCS2 as currently in the prior art.

5 BRIEF DESCRIPTION OF THE DRAWINGS

An embodiment of the invention will now be described by way of example with reference to the accompanying drawings in which:

Fig. 1 is a schematic overview of an embodiment of the invention;

10 Fig. 2 illustrates the form of a message sent by the sender;

Figs. 3a-3b illustrate different types of message as received by the recipient;

Figs. 4a – 4d illustrate different forms of message associated with a response by a recipient to the message; and

Fig 5 illustrates the form of a data message to update advertising information.

15 Fig. 6 illustrates an SMS submit envelope; and

Fig. 7 illustrates a modified form of envelope for use with messages having characters from two character sets.

DETAILED DESCRIPTION OF THE PREFERRED EMBODIMENT

20

A schematic overview of an embodiment of the invention is shown in Figure 1, showing the relevant functional blocks and messages sent from a mobile telephone sender to a mobile telephone recipient via a mobile communications network



The described embodiment uses the GSM system and the SMS service of that system, to which the invention is particularly applicable. However, the invention is applicable also to other communications systems as will be apparent to one skilled in the art.

5 The described embodiment allows a user (sender) to send an SMS message together with an advertisement, the advertisement being selected by the sender to be sent to the recipient with the message. The described embodiment thus allows advertising to be essentially peer to peer.

10 Since SMS is a limited length text message service, the length of the advertisement is deducted from the length of the message, the sender then composing the text message within the remaining space.

In the description below, the particular features necessary for a user's mobile telephone  
15 to provide sending functions (as a message sender) and receiving functions (as a message recipient) are described separately for ease of explanation. In general, however, a user's mobile telephone will have both sending and receiving capability and thus the sending and receiving functions will be combined in each user's telephone.

20 The sender's mobile telephone is of standard construction, having a processor, memory and appropriate telecommunications circuitry. The telephone also has a SIM card, personal to the sender. The described embodiment is effected in the sender's mobile telephone by adaptation of the software to provide the functions to be described. A control program (for sending) in the form of software residing on the SIM card or the

mobile telephone is provided which controls the operation of the telephone in assembling the SMS message. This interacts with the user via a menu 1 of advertisements to be selected which is available to the user for example as a sub menu of a "compose messages" screen of the mobile telephone. The menu is linked to a data store 2 stored in memory which stores a preview or précis of each advertisement for viewing by the sender.

The user may select to have a given advertisement appended to every message sent by setting a preference in the telephone or may select an advertisement each time a message is sent. Only one message may be selectable (the selection being to send the advertisement or not) and/or the advertisement may be selectable from a plurality of selectable advertisements.

In accordance with the sender's selection, the control program consults the data store 2 which includes, for each advertisement, an advertisement ID or tag and advertisement length. Preferably the menu displays the advertisement preview which is mapped directly to the ID which is related to the advertisement content in a meaningful way. For example an advertisement for IBM products could have the ID "IBM" and the preview "IBM-THE BEST" and an advertisement for Nike products could have the ID "NIKE" and preview "NIKE-JUST DO IT".

The advertisement ID may also be input by the user directly using a free text field provided as part or instead of the menu. In such an instance, the information to be provided by the user would include the ID, preview and the advertisement length and

this information would be entered by the user and stored in the data store for immediate use and/or subsequent retrieval. Advertisement ID, preview and length information for the user's use may be provided by any means extenal to the mobile telephone such as in service-related literature or advertisements and other information provided in media  
5 such as print, radio, television or web-based.

From the selected advertisement length, the control program calculates an available message length, this being the fixed message length minus the advertisement length and allows text input 3 only to that available message length, this text input being stored in  
10 memory 4. Once the sender has completed the message text, the control program assembles the message by adding a header to the message text of the form shown in Fig. 2. As shown, the header has an identifier, to indicate that the message has additional advertising content, which in this case is illustrated by the characters “&&&”, which is followed by the Advertisement ID and the message text.

15  
In an alternative form, the advertisement preview can form the actual advertisement with this replacing the advertisement ID, particularly if the advertisement is of short length. Thus if the preview is “Nike – Just Do It”, this could be appended to the message directly. In such case the indicator “&&&” and ID may be omitted and the  
20 message processed like any normal SMS message, although the header and the preview (placed in the ID field) may still be included and the message processed as described below.

Other header structures are used for other functions, as described below.

The header enables the mobile communications network to determine how to process the SMS message before delivery to the recipient. Once the message has been assembled, the sender sends the message 5 in the normal way. This is received by the SMS message center SMSC which determines the indicator “&&&” and passes the message 6 to an advertisement server together with the usual message information such as sender and recipient. The server includes a message analyzing unit 7 which identifies the header structure and passes the message to a message processing unit 8 which processes the message accordingly. The server is connected to a subscriber database 9 in which details of all the advertisements sent by a particular subscriber may be stored.

For the header structure shown in Fig. 2, the unit 8 extracts the advertisement ID and then pulls the relevant advertisement from an advertisement database 10 which includes all Ids, previews and full advertisements and other advertisement-related information. A check is then made of the subscriber database 9 to determine if the recipient of the message is a subscriber, in the sense that the database has a record of the receiver having receiver software, described below, present on his/her mobile telephone. The database will also preferably have an indication of the power and type of the recipient's mobile phone, in particular the ability of the telephone to execute multi-media messages.

If so, a type ID which will be recognised by the receiver/subscriber's mobile telephone is applied at the start of the header replacing the indicator “&&&” before the combined message 12 is passed to intermediate memory 11 and then back to the SMSC for

onward transmission to the recipient's mobile telephone. For normal message transmission, the type ID is "0x31", as shown in Fig. 3a. If the message itself is already attached, this will be plain from the content of the advertisement ID which will be the preview rather than the ID in which case the step of appending the advertisement is  
5 omitted, since this is already attached.

In an alternative, the unit 8 may select or change the advertisement or message. For example, the message may be parsed by the unit 8 and certain character(s) in the message replaced by the unit 8 by special characters or icons. For example, in a  
10 message having a cola advertisement, the letter "I" where this appears in the message could be replaced in the message by an icon of a cola bottle, with the advertisement for the brand of cola then being appended to the message. Alternatively, an enhanced advertisement may be sent to a receiver/subscriber, which may exceed the size limit of the message. In such a case a plurality of messages of the form shown in Fig. 3b are  
15 constructed, each message being a part of the whole. The message has a type ID "0x32" and includes an additional message ID field which identifies the message, so that the parts can be reassembled and a part ID field which identifies the total number of parts and the position of that part in the whole. The enhanced message may be simply longer or may have multi-media components, if the receiver/subscriber has the capability to  
20 execute such advertisements indicated in the database 9.

If the receiver is not a subscriber, the combined message is sent back to the SMSC without the type ID and the advertisement ID.

The SMSC then transmits the completed message 13 to the recipient's mobile telephone. The recipient's mobile telephone is of standard construction, having a processor, memory and appropriate telecommunications circuitry. The telephone also has a SIM card, personal to the sender. It is not necessary for the receiver to have any software modification to receive the combined SMS message in which case the receiver would not be a subscriber and the combined message would be like a normal SMS message as described in the preceding paragraph. However, if the receiver is a subscriber, the software of the recipient's mobile telephone is modified to provide the functions to be described.

10

A control program (for receiving) in the form of software residing on the mobile telephone or SIM card is provided which controls the operation of the telephone in processing the received message.

15 Once the message has been received, the control program performs a message processing function 14 according to the type of message received, determined by the type ID field of the received message.

If the message has type ID "0x31" shown in Figure 3a, the complete message is simply displayed on the screen of the user's mobile telephone, with the message thus comprising the message text followed by the advertisement.

20

If the message has type ID "0x32" shown in Figure 3b, this indicates that the message is in more than one part. The message is stored until all parts have been received at

which time the message parts are concatenated and displayed together. The control program sends a blank message back to the OTA Server to acknowledge receipt of each part.

- 5 The recipient may interact with the received message in several ways by using menu driven options for response indicated at 15 in Fig. 1:
1. The recipient can request more information about the advertisement. In such a case, the control program constructs a reply SMS of the form shown in Figure 4a in which the identifier “&&&” is followed by an indicator “A” and the advertisement ID from the received message. This is sent to the server in the manner of a normal sent message, but the unit 8 extracts more information about the advertisement stored in the database and assembles a reply message of the form shown in Figure 3a, the message text of which contains the additional information requested and this is sent to the recipient.  
10
  - 15 2. The recipient can place a call to the advertiser . This is achieved by constructing a message of the form shown in Fig. 4b in which the identifier “&&&” is followed by an indicator “B” and the advertisement ID. This message is sent to the server in the manner of a normal sent message, but the unit 8 extracts the advertiser’s telephone number stored in the database and assembles a reply message of the form shown in Figure 3a, the message text of which contains the telephone number requested and this is sent to the recipient.  
20

3. The recipient may forward the message to a third party in which case the advertisement ID is detached from the message and assembled into a message of the form shown in Figure 3a which is sent by the receiver to the third party.
- 5
4. The recipient may save the advertisement for sending with future SMS messages. In such a case, the control program constructs a reply SMS of the form shown in Figure 4c in which the identifier “&&&” is followed by an indicator “C” and the advertisement ID from the received message. This is sent to the server in the manner of a normal sent message, but the unit 8 extracts information about the advertisement stored in the database and assembles a reply message of the form shown in Figure 4d, the message text of which contains the additional information requested and this is sent to the recipient. The reply message has a different type ID “0x33” and includes the information necessary for the advertisement to be stored in the data store of the recipient, namely, the advertisement length, ID and preview. This message is sent to the recipient and upon receipt, the control program stores the information in the recipient’s database.
- 10
- 15
- 20 The above-described operations are initiated either by a sender or a recipient. There may be occasions, however, when the service provider, or an advertiser, wishes to update the advertisement details on the sender’s mobile telephone. In such a case, a database update message (18, 19) having the form shown in Fig. 5 is sent from the server to the sender. Such a message has a Type ID “0x30” and comprises information



of all the advertisements that can be selected. The control program processes the message in the same way as described in numbered paragraph 4 above.

The advertisement may be of any suitable form, e.g. text, graphics or even audio if supported by the recipient's communication device. In this respect although the invention has been described as applied to mobile telephone communication, this is not to be construed as limitative and the general idea of a sender/user selecting an advertisement to be included in any way with a message of whatever form to be sent to a recipient, be it SMS, EMS, MMS, email, voice mail or fax, originating from any kind of communication device such as a PC, fixed or mobile telephone, paging or email device is envisaged within the scope of the invention.

The described embodiment is of particular use as part of a business method to allow users of mobile telephones to advertise on behalf of third parties in return for some reward. In this respect a track is kept of advertisements sent by any particular user and details are in association with the user in the subscriber database 10, to be used as a basis for calculation of a discount on services provided, accumulation of points to be redeemed as a discount or in full for products of the advertiser or any other such reward scheme. As an example, a Cola manufacturer may have a scheme whereby the sender will be rewarded with a free can of cola or an appropriate voucher if the sender sends ten Cola advertisements.

It is necessary for a record to be kept of the advertisements sent. In one preferred form, since all such messages pass through the server, the server maintains a counter in the

subscriber database associated with the sender to keep track of the SMS messages sent by the sender to which the advertisement is appended and alerts the manufacturer when the tenth message has been sent and sends an acknowledgment SMS to the sender. In another preferred form, the counter is provided by the software in the sender's SIM card  
5 or telephone and upon sending the tenth message and after receipt of the normal successful delivery SMS reply message, the software constructs a message of a form similar to that shown in Fig. 4a, but with the identifier "D" instead of "A" which is sent to the server, the server on receipt of the message alerting the manufacturer and sending an acknowledgment SMS to the sender.

10

The selection of advertisement by the sender can provide a valuable source of information and statistics for advertisers. Since the act of selection is essentially an act of choice, the information on the number and selection of advertisements sent can provide information useful in profiling the buying habits, likes and dislikes of the sender  
15 and to a certain extent the receiver, since the sender might choose an advertisement on the basis of possible interest to the receiver. The same applies to responses made by a receiver/subscriber to receipt of an advertisement, since this would give a greater indication of interest by the receiver in the subject of the advertisement. The database preferably includes suitable profiling information of subscribers, such as age, gender,  
20 profession etc, provided at the time of subscription, to allow the advertisers to interpret the advertisement selections in a meaningful way.

An optional feature of this embodiment will now be described allows compression of a Multi-lingual SMS(with different coding schemes -English and other Latin characters

are coded in ASCII(7-bit) and Chinese, Japanese are coded in UCS2(16-bit). This means that when an Advertisement in Chinese is appended to an SMS containing English characters, the English characters are not converted to UCS2. Instead the software running on the client retains the string in ASCII and appends an identifier (a 7-bit special character in this case but more generally an identifier) before the UCS2 coded characters are appended. This allows the software residing on the recipient's mobile phone to understand that every time it encounters the identifier (special character), the character coding following the identifier changes.

The allowable length of an SMS is dependent on the character set. If there is even one Chinese character in an otherwise-English message, the allowable length decreases by half. This is because 7 bit ASCII coding is used for English characters and a maximum of 160 English characters can be transmitted in one SMS.

The maximum capacity of a SMS message is

$$140 \text{ octets} = 14 \times 8 \text{ bits} \text{ ----- (i)}$$

The packing of the 7-bits characters in octets is done by completing the octets with zeros on the left.

For example, packing of:  
one character (represented by bits 1a – 1g) in one octet:

7	6	5	4	3	2	1	0
0	1a	1b	1c	1d	1e	1f	1g

packing of two characters (represented by bits 1a – 1g and 2a – 2g) in two octets:

7	6	5	4	3	2	1	0
2g	1a	1b	1c	1d	1e	1f	1g
0	0	2a	2b	2c	2d	2e	2f

Similarly, eight characters in seven octets would look like this:

	7	6	5	4	3	2	1	0
	2g	1a	1b	1c	1d	1e	1f	1g
	3f	3g	2a	2b	2c	2d	2e	2f
5	4e	4f	4g	3a	3b	3c	3d	3e
	5d	5e	5f	5g	4a	4b	4c	4d
	6c	6d	6e	6f	6g	5a	5b	5c
	7b	7c	7d	7e	7f	7g	6a	6b
10	8a	8b	8c	8d	8e	8f	8g	7a

Hence a maximum of 160 alphabet characters can be transmitted in a SMS message

$$140 \times 8/7 = 160 \text{ ----- (ii)}$$

However, if one of the alphabet characters is in Universal Multiple-Octet Coded Character Set 2 (UCS2) which has 16-bit encoding then all the Latin alphabet characters are changed from the 7 bit ASCII character set to the 16 bit UCS2 character set. The maximum capacity of the SMS message in this case is 70 characters:

$$140 \times 8/16 = 70 \text{ ----- (iii)}$$

Thus, for example, a text which contained 140 English alphabet characters cannot be accommodated into one SMS message because of the addition of one Chinese (UCS DCS) character.

Figure 6 shows the structure of an SMS. The maximum amount of user data that can be transmitted in an SMS is 140 octets or 140x8 bits. According to this feature of the described embodiment of the invention, characters from two character sets such as ASCII and UCS2 may be combined with only minimal loss of capacity.

To give an example, for a situation where the primary text is in English (of length 120 characters) and the advertisement is in Chinese (of length 5), then English characters (which are in ASCII format) require 105 octets ( $7 \times 120/8 = 105$ ). Chinese characters

which use the UCS2 data coding scheme, utilize 10 octets ( $5 \times 2 = 10$ ); since each Chinese character requires 2 octets of space to be completely represented. The special character (data code) that is appended, to indicate the change in data coding scheme is 7 bits long, like any ASCII character but one that is not used in the ASCII character set.

- 5 A suitable blank or unused data code that could be used for this purpose is any of ASCII characters 0-8 & 127. Hence, the final data unit is 116 bytes long. Padding zeros are appended to the end of the bit string to ensure that it is divisible by 8.

The user data thus has the form shown in Fig. 7.

10

Optionally, further blocks of characters may be added changing between the first character set (ASCII) and the second (UCS) or vice versa, by adding further instances of the special character between the blocks.

- 15 The following method is employed when the first few characters entered are Latin characters:

Step 1: Get the user input until a non ASCII character is encountered.

Step 2: Insert a 7-bit special character to the user input to indicate to the software residing on the phone that the next entry is in a different coding scheme (UCS2 in this case)

20

Step 3: Get the UCS2 DCS input & split the 16-bit entry into two octets, each 8 bits in length and append to the existing primary text

Step 4 (Optional): Get user input until a ASCII character is encountered

Step 5 (Optional): Insert a special character to the user input to indicate to the software residing on the phone that the next entry is in a different coding scheme(7 bit ASCII characters in this case)

Step 6 (Optional): Append the ASCII characters to the existing string (primary text of  
5 SMS).

Step 7: the appended string forms the user data

Optional steps 4 – 6 may be repeated until all the changes between character sets have been processed.

10

The software residing on the recipient's mobile terminal/SIM card converts all the ASCII characters into UCS2 characters so that the whole message can be displayed to the user. The following are the steps required:

Step 1: Start extracting the 7-bit Latin characters and replace them with the equivalents  
15 in UCS2 character coding.

Step 2: The software contains a mapping between 7 bit ASCII coding and the corresponding 16-bit representation in UCS2 (for instance 'A' in ASCII coding & UCS2 Coding) and displays the UCS2 encoded character. This step is necessary  
because all characters have to be represented in the same data coding scheme  
20 (ASCII/UCS2 in this case) before displaying.

Step 3: When the identifier/special character is encountered delete the identifier from the string and start reading 16 bit characters (UCS2) that follow. Display them

Step 4 (Optional): When another special character is encountered indicating a change in the data coding scheme of the characters that follow, then delete the special character/identifier and go to Step1.

Step 5: End – All characters have been displayed.

5

It can be seen that by separating (and flagging) the USC2 encoded characters from the ASCII encoded characters, it is possible to maintain both sets of characters in their original coding form, so it is now possible in the described embodiment to combine USC2 and ASCII coded characters thus allowing more text to be sent in a combined

10 character set SMS message than before.

CLAIMS

1. A method of including advertising content in a message sent from a sender to a recipient comprising the steps of the sender selecting an advertisement to be  
5 included with the message and sending the message together with the advertisement or an indication thereof to the recipient.
2. A method as claimed in claim 1 wherein the message is size-limited with the advertisement reducing the available message size to that remaining within the size  
10 limit and the sender composing the message within the available message size.
3. A method as claimed in claim 1 or claim 2 wherein the message is a SMS message.
4. A method as claimed in claim 3 wherein the message is sent to and/or from a GSM  
15 mobile telephone.
5. A method as claimed in any one of the preceding claims wherein the message is sent via a service provider or other entity associated with the method.
- 20 6. A method as claimed in any one of the preceding claims wherein the sender includes the advertisement with the message.



7. A method as claimed in claim 5 wherein the sender includes a tag designating the advertisement and the entity attaches the advertisement to the message en route to the recipient.
- 5 8. A method as claimed in claim 7 in which the message includes an indicator, an advertisement ID and message text, the indicator identifying the message to the server and the ID identifying the advertisement to be included with the message text.
9. A method as claimed in claim 7 or claim 8 wherein the entity selects or changes the  
10 nature of the advertisement or changes the message in accordance with the advertisement sent by the sender.
10. A method as claimed in claim 8 wherein the nature of the advertisement selected or changed by the entity is the size of the advertisement.
- 15 11. A method as claimed in claim 8 or claim 9 wherein the nature of the advertisement selected or changed by the entity is the media of the advertisement.
12. A method as claimed in any one of the preceding claims wherein the advertisement  
20 may be selected by the sender from a plurality of available advertisements.
13. A method as claimed in claim 10 wherein the plurality of advertisements is provided by means of a menu provided on a communication device of the sender.

14. A method as claimed in claim 10 wherein available advertisements are provided from at least one source other than a communication device of the sender.
15. A method as claimed in any one claims 5 or 7 to 14 wherein the entity splits the  
5 combined message and advertisement into at least two separate messages, the whole message being reassembled from the separate messages by the recipient.
16. A method as claimed in any one of claims 5 or 7 to 15 wherein the entity counts the  
10 number of times each advertisement selected by the sender is sent and stores this information in association with the sender.
17. A method as claimed in claim 16 wherein the entity sends a notification to an advertiser or performs a reward-based operation for the sender when the number of  
15 times a said advertisement or plurality of said advertisements is sent exceeds a threshold.
18. A communication device having a message sending capability and the device having a memory arranged to store an advertisement or an indication thereof, interactive means arranged to allow selection of the advertisement or indication for sending  
20 with a said message and means for sending the message to a recipient.
19. A device as claimed in claim 18 wherein the message is of a limited size.

20. A device as claimed in claim 19 further comprising processing means arranged to limit the available message size to that unoccupied by the advertisement.
21. A device as claimed in any one of claims 18 to 20 being a mobile telephone having  
5 a SMS capability.
22. A device as claimed in any one of claims 18 to 21 wherein the advertisement is stored in the device.
- 10 23. A device as claimed in any one of claims 18 to 21 wherein a tag indicating the advertisement is stored in the device.
24. A service providing entity comprising a database of advertisements and processing means arranged to receive a message from a subscriber, attach an advertisement  
15 from the database to the message in accordance with a selection by the subscriber and forward the message for delivery to a recipient.
25. An entity as claimed in claim 24 further comprising database of subscribers.
- 20 26. An entity as claimed in claim 25 wherein the processing means is arranged to keep the database of subscribers updated with information of the advertisements selected by the subscribers.

27. A method of providing a communication-related service to a user comprising the steps of providing at least one advertisement to the user, the user being able selectively to append the advertisement to a communication from the user to a recipient, a reward being given to the user if the selection is made.
- 5
28. A method as claimed in claim 27 wherein the reward is given by a communication service provider.
29. A method as claimed in claim 28 wherein the reward is a rebate or discount of
- 10 communication charges.
30. A method as claimed in claim 27 wherein the reward is given by an advertiser.
31. A method as claimed in claim 30 wherein the reward is in the form of a discounts or
- 15 rebate which may be put towards purchases or exchanged for the advertiser's goods or services.
32. A method as claimed in any one claims 27 to 30 wherein track of the advertisements that are sent by the user is kept so that the user may be appropriately rewarded.
- 20
33. A method as claimed in claim 32 wherein the tracking is performed by a service entity through which all the communications are channeled.

34. A method of collecting advertising-related data comprising the steps of providing a plurality of advertisements to a plurality of users, each user being able selectively to include a said advertisement with a communication from the user to a recipient, and determining the number of times each advertisement is sent.
- 5
35. A method as claimed in claim 34 wherein the collected data is profiled based on the users selecting the advertisements.
36. A method as claimed in claim 35 wherein the data is profiled based on the age,  
10 gender and/or profession of the users.
37. A method as claimed in any one of claims 34 to 36 further comprising the step of collecting data based on the responses of recipients to the advertisements sent.
- 15 38. A method of assembling a size-limited message having character data encoded using first and second character sets, the coding bits per character in the first character set being less than the coding per character in the second character set comprising the steps of
- (i) identifying any character(s) of one character set in the message; and
- 20 (ii) marking the character(s) of the other character set with a flag to distinguish from the characters of the one character set.
39. A method as claimed in claim 38 wherein the first character sets is ASCII and the second is UCS.

40. A method as claimed in claim 38 or claim 39 wherein the characters in one or other of the character sets form an advertisement as claimed in the method of any one of claims 1-17 and 27-37, the device of claims 18-23 or the entity of claims 24-26.

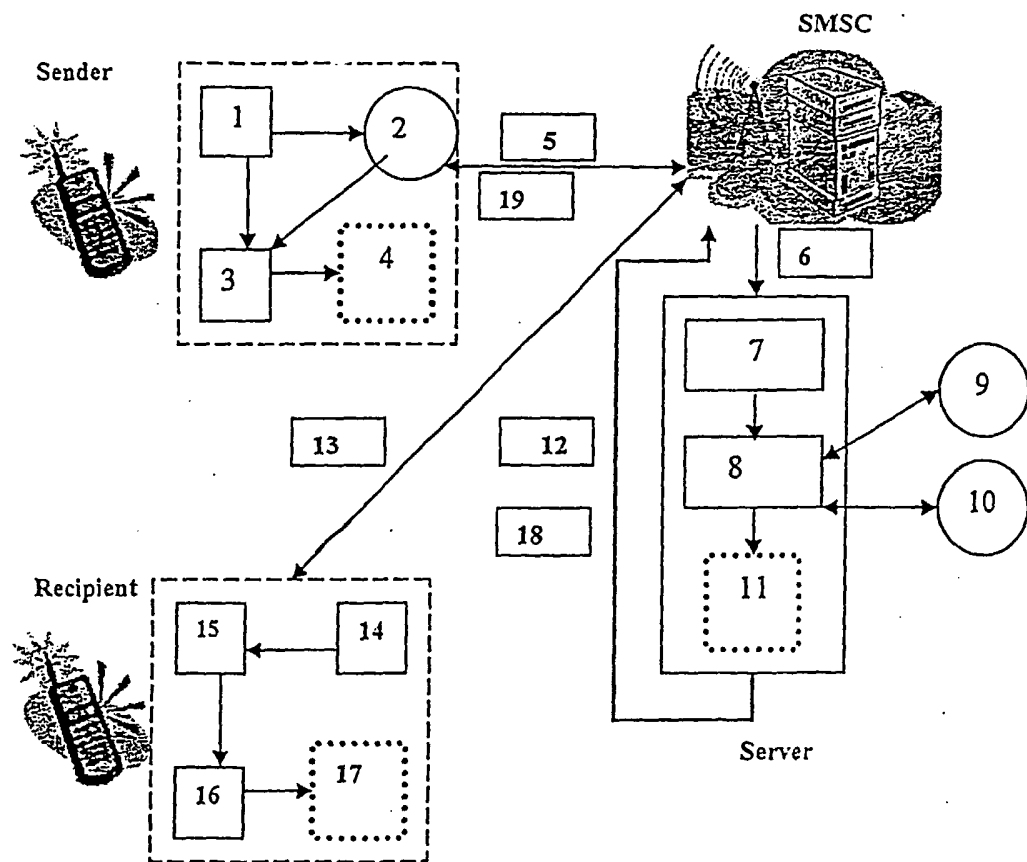

Fig. 1

&&&	Ad ID	Message
-----	-------	---------

Fig. 2

TypeID	ADId	Message to be displayed
--------	------	-------------------------

Fig. 3a

TypeID	MsgID	PartID	Data
--------	-------	--------	------

Fig. 3b

&&&	A	AD Id
-----	---	-------

Fig. 4a

&&&	B	AD Id
-----	---	-------

Fig. 4b

&&&	C	AD Id
-----	---	-------

Fig. 4c

TypeID	Ad length	AD Id	Ad Preview
--------	-----------	-------	------------

Fig. 4d



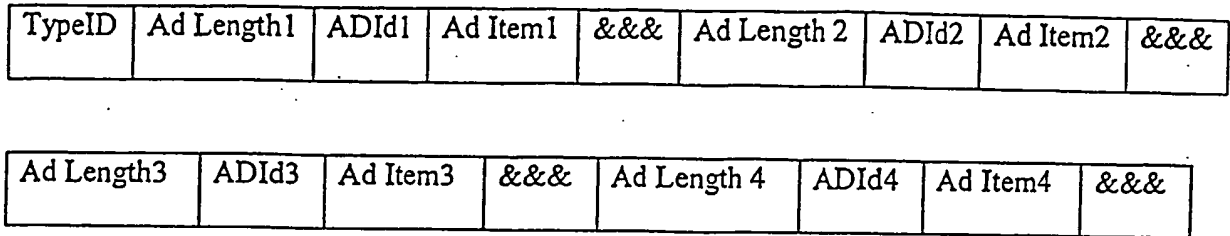

Fig. 5

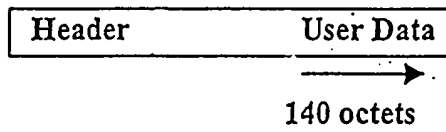

Fig. 6

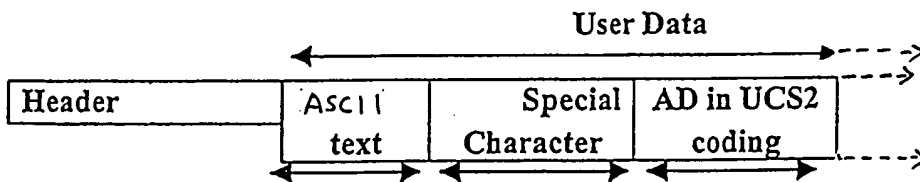

Fig. 7

## INTERNATIONAL SEARCH REPORT

International application No.  
PCT/SG 02/00103

## CLASSIFICATION OF SUBJECT MATTER

IPC<sup>7</sup>: H04Q 7/22, H04M 3/487

According to International Patent Classification (IPC) or to both national classification and IPC

## B. FIELDS SEARCHED

Minimum documentation searched (classification system followed by classification symbols)

IPC<sup>7</sup>: H04Q, H04M

Documentation searched other than minimum documentation to the extent that such documents are included in the fields searched

Electronic data base consulted during the international search (name of data base and, where practicable, search terms used)

WPI, EPODOC, PAJ

## C. DOCUMENTS CONSIDERED TO BE RELEVANT

Category	Citation of document, with indication, where appropriate, of the relevant passages	Relevant to claim No.
X,P	JP 2002 140272 A (DENSO CORP) 17 May 2002 (17.05.02) <i>abstract, figs. 3-5; paragraphs [0015] - [0029].</i>	1,5,7,12-14,16-18,23,24,27,30,32-34
A	WO 00/44151 A2 (SONY COMPUTER ENTERTAINMENT INC.) 27 July 2000 (27.07.00) <i>abstract, figs. 4,5,9-11; page 11, line 24 - page 19, line 10; page 20, line 3 - page 21, line 19.</i>	1,18,24,27,34
A	WO 01/22748 A1 (NEOPOINT, INC.) 29 March 2001 (29.03.01) <i>abstract, figs. 15-17; page 2, line 13 - page 3, line 20; page 24, line 10 - page 26, line 17.</i>	1,18,24,27,34
A	WO 99/52247 A1 (WERKANDER, P.) 14 October 1999 (14.10.99) <i>abstract, figs. 2-4; page 7, line 33 - page 8, line 24.</i>	38

 Further documents are listed in the continuation of Box C. See patent family annex.

\* Special categories of cited documents:

„A“ document defining the general state of the art which is not considered to be of particular relevance

„E“ earlier application or patent but published on or after the international filing date

„L“ document which may throw doubts on priority claim(s) or which is cited to establish the publication date of another citation or other special reason (as specified)

„O“ document referring to an oral disclosure, use, exhibition or other means

„P“ document published prior to the international filing date but later than the priority date claimed

„T“ later document published after the international filing date or priority date and not in conflict with the application but cited to understand the principle or theory underlying the invention

„X“ document of particular relevance; the claimed invention cannot be considered novel or cannot be considered to involve an inventive step when the document is taken alone

„Y“ document of particular relevance; the claimed invention cannot be considered to involve an inventive step when the document is combined with one or more other such documents, such combination being obvious to a person skilled in the art

„&amp;“ document member of the same patent family

Date of the actual completion of the international search

11 November 2002 (11.11.2002)

Date of mailing of the international search report

20 November 2002 (20.11.2002)

Name and mailing address of the ISA/AT  
Austrian Patent Office  
Kohlmarkt 8-10; A-1014 Vienna  
Facsimile No. 1/53424/535

Authorized officer

LOIBNER K.

Telephone No. 1/53424/323

## INTERNATIONAL SEARCH REPORT

International application No.

PCT/SG 02/00103

C (Continuation). DOCUMENTS CONSIDERED TO BE RELEVANT

Category*	Citation of document, with indication, where appropriate, of the relevant passages	Relevant to claim No.
A	DE 19549059 A1 (SIEMENS AG) 3 July 1997 (03.07.97) <i>abstract; column 2, lines 10-28.</i> -----	38

# INTERNATIONAL SEARCH REPORT

International application No.  
PCT/SG 02/00103

## Box I Observations where certain claims were found unsearchable (Continuation of item 1 of first sheet)

This international search report has not been established in respect of certain claims under Article 17(2)(a) for the following reasons:

1.  Claims Nos.:  
because they relate to subject matter not required to be searched by this Authority, namely:
  
2.  Claims Nos.:  
because they relate to parts of the international application that do not comply with the prescribed requirements to such an extent that no meaningful international search can be carried out, specifically:
  
3.  Claims Nos.:  
because they are dependent claims and are not drafted in accordance with the second and third sentences of Rule 6.4(a).

## Box II Observations where unity of invention is lacking (Continuation of item 2 of first sheet)

This International Searching Authority found multiple inventions in this international application, as follows:

see extra sheet

1.  As all required additional search fees were timely paid by the applicant, this international search report covers all searchable claims.
2.  As all searchable claims could be searched without effort justifying an additional fee, this Authority did not invite payment of any additional fee.
3.  As only some of the required additional search fees were timely paid by the applicant, this international search report covers only those claims for which fees were paid, specifically claims Nos.:
  
4.  No required additional search fees were timely paid by the applicant. Consequently, this international search report is restricted to the invention first mentioned in the claims; it is covered by claims Nos.:

### Remark on Protest

- The additional search fees were accompanied by the applicant's protest.  
 No protest accompanied the payment of additional search fees.

Continuation of Box II:

Group I, Claims 1-37, drawn to a method of including advertising content in a message sent from a sender to a recipient (Claims 1-17) and a communication device having a message sending capability (Claims 18-23) and a service providing entity (Claims 24-26) and a method of providing a communication-related service (Claims 27-33) and a method of collecting advertising-related data (Claims 34-37), wherein each sender of a message is able to selectively include said advertising content in order to get a reward for sending said message including said advertising content.

Group II, Claims 38-40, drawn to a method of assembling a size-limited message having encoded character data using two different character sets.

The inventions listed as Groups I and II do not relate to a single inventive concept under PCT Rule 13.1 because, under PCT Rule 13.2, they lack the same or corresponding special technical features for the following reasons:

The special technical feature of Group I invention is the method of including advertising content in a message sent from a sender to a recipient, wherein said advertising content has been actively selected by the sender of said message.

The special technical feature of Group II invention is the method of assembling a size-limited message having different character sets using two different character encoding standards, e.g. ASCII and UCS encoding standards.

Since the special technical feature of Group I invention not present in Group II claims and the special technical features of Group II invention is not present in Group I claims, unity of invention is lacking.

## INTERNATIONAL SEARCH REPORT

Information on patent family members

International application No.  
PCT/SG 02/00103-0

Patent document cited in search report			Publication date	Patent family member(s)			Publication date
DE	A1	19549059	03-07-1997	CN	A	1158546	03-09-1997
JP	A2	02140272	17-05-2002	none			
WO	A	044151		none			
WO	A	122748		none			
WO	A2	9952247	14-10-1999	AU	A1	33494/99	25-10-1999
WO	A3	9952247	02-12-1999	AU	B2	749528	27-06-2002
				CA	AA	2325035	14-10-1999
				EP	A2	1076966	21-02-2001
				IL	A0	138583	31-10-2001
				JP	T2	02510938	09-04-2002
				NZ	A	507072	28-03-2002
				SE	A0	9800992	24-03-1998
				SE	A	9800992	25-09-1999
				SE	C2	511994	10-01-2000