

(12) UK Patent Application (19) GB (11) 2 154 550 A

(43) Application published 11 Sep 1985

(21) Application No 8501109

(22) Date of filing 16 Jan 1985

(30) Priority data

(31) 8404348 (32) 18 Feb 1984 (33) GB

(71) Applicant
Mardon Illingworth Limited (United Kingdom),
Forest Works, Coxmoor Road, Sutton-in-Ashfield,
Nottinghamshire NG17 5LH

(72) Inventor
Henryk Dudzik

(74) Agent and/or Address for Service
Eric Potter & Clarkson,
14 Oxford Street, Nottingham NG1 5BP

(51) INT CL⁴
B65D 25/10

(52) Domestic classification
B8P K5
U1S 2119 B8P

(56) Documents cited
GB 1163809 US 4294558
GB 0697995 US 4225014
GB 0561126 US 0371028

(58) Field of search
B8P

(54) Container

(57) A container e.g. for an audio disc (10) comprises covers (11, 13) joined to a spine (12) by parallel hinges (21, 22). A holder (14) is fixed to the spine. The hinges permit initial opening of one cover (13) relative to the spine (12) about one hinge (21), after which the spine moves with the cover (13) about the other hinge (22) so that the holder is raised away from the other cover (11) to present the contents in a readily accessible position. The covers and the spine may be defined by a single sheet marked with lines of weakness to define the hinges, with reinforcing frames (11a, 13a) on the cover portions. The holder (14) and the frames (11a, 13a) may be moulded onto the sheet which may be made of polypropylene.

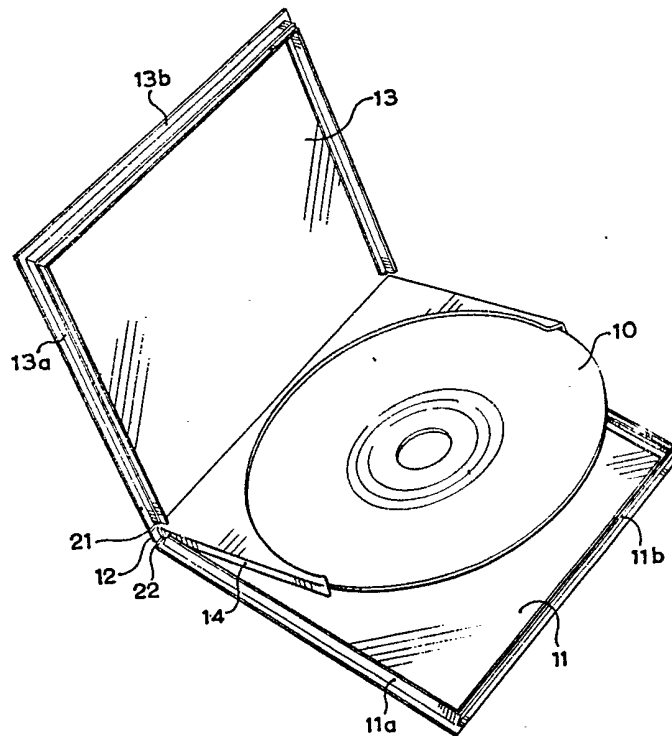

FIG.1

GB 2 154 550 A

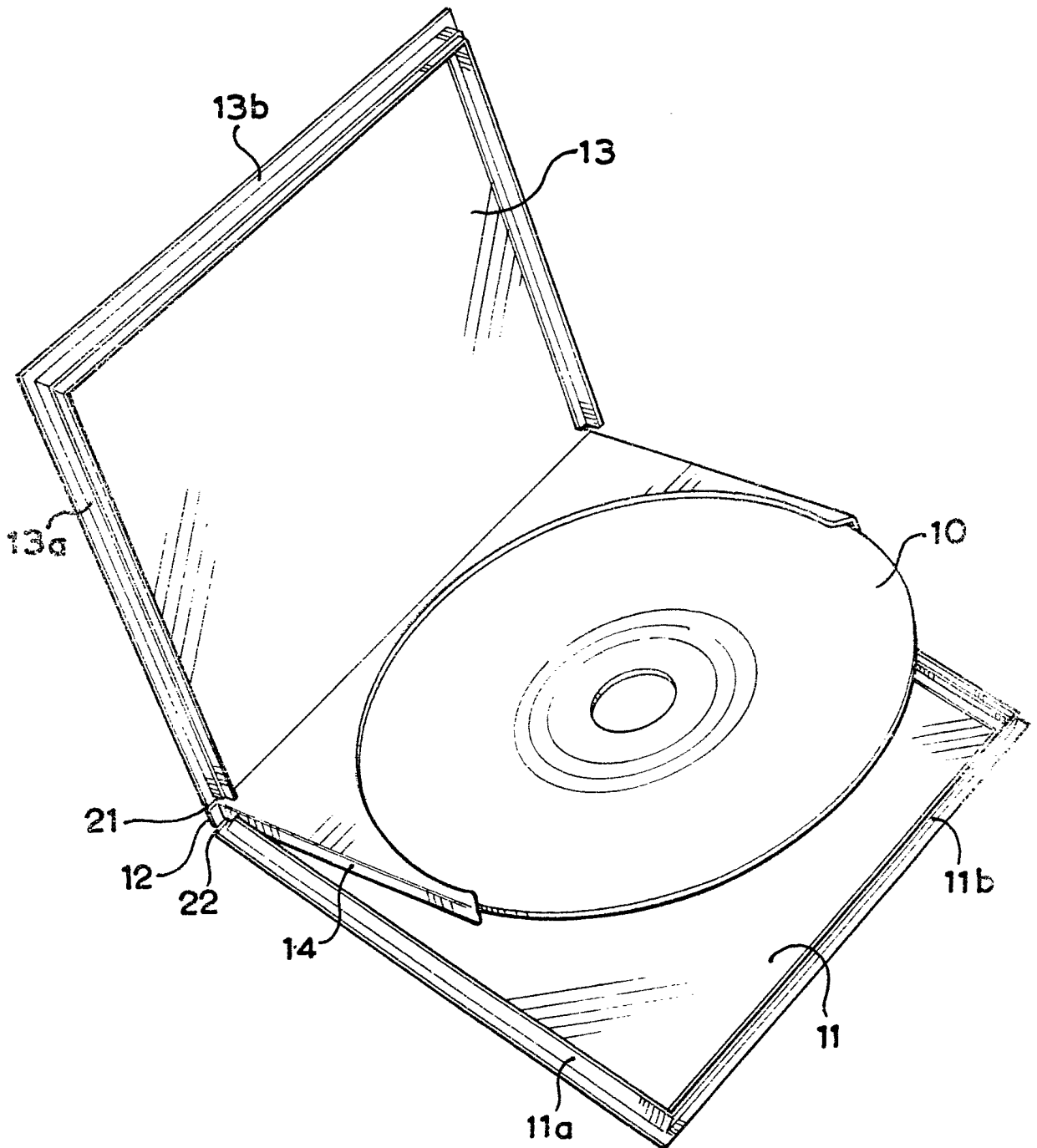

FIG. 1

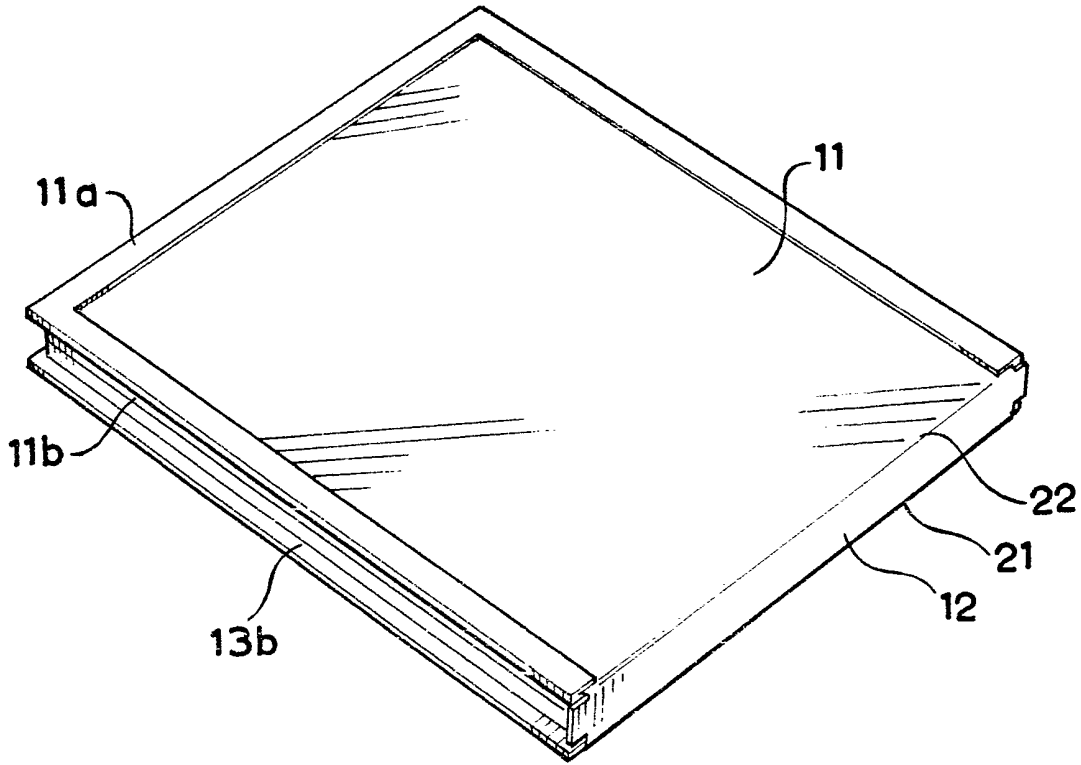

FIG. 2

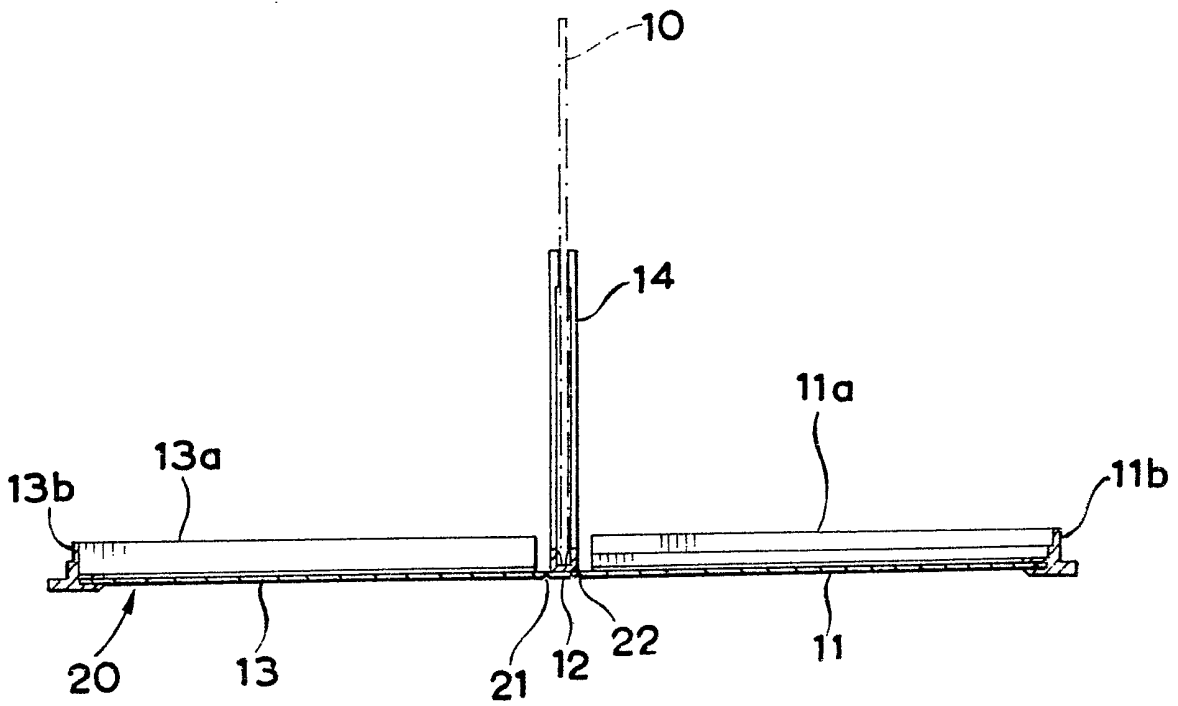

FIG. 3

SPECIFICATION

Container

5 This invention relates to containers of the type comprising a pair of hinged covers engageable to form an enclosure between the covers.

Such a container is of shallow depth relative to the dimensions of length and breadth and at least one of the covers usually has side walls. Such containers are used, for example to house compact audio discs.

In such containers, the contents are usually housed in one of the covers and, e.g. in the case of a disc, it can be awkward to remove the disc. It would often be convenient for the contents to be presented in a position for easy removal.

The present invention provides a container comprising first and second hinged covers engageable to form an enclosure between the covers, a spine to which the first and second covers are hinged along parallel opposite edges of the spine by first and second hinges respectively, and a holder fixed to the spine and enclosed between the covers in the engaged position of the latter, whereby the covers can be disengaged and pivotally moved to an open position, the spine being pivotally movable with the first cover about the second hinge axis after the first cover has been moved a predetermined angle about the first hinge axis, whereby the holder is pivotally moved by the spine to a position angularly spaced from both covers to facilitate access to the holder.

The holder, therefore, presents the contents in a readily accessible position for removal. The contents could be, for example, a set of drills or other tools or cosmetic articles.

It is preferred that at least one of the covers has side walls.

Reference is now made to the accompanying drawings, wherein:-

Figure 1 is a perspective view of a container according to the invention, shown in partly open position;

Figure 2 is a perspective view of a container shown in closed position; and

Figure 3 is a sectional view of the container in fully open position.

The container shown is intended for holding an audio disc 10. The container comprises a first and second covers 11, 13 and a spine 12. As most clearly shown in Figure 3, the covers and the spine are defined by portions of a single sheet 20 of polypropylene. A pair of parallel grooves are formed by scoring in one face of the sheet to define hinges 21, 22. The spine 12 is defined between the hinges.

Each cover 11, 13 is reinforced by a rectangular frame 11a, 13a moulded on to the sheet. The frames are formed by injection moulding from polypropylene. Each frame extends along the edges of each cover, except for the edge defined by one of the hinges 21, 22. In the completed container, the marginal edges of the sheet lie in rebates in the frames, so that the edges are protected. The frame portions 11b, 13b parallel to the hinges have for-

mations which interengage to hold the covers in the closed position illustrated in Figure 2.

A holder 14 is also moulded onto the spine 12 of the sheet 20 and is also made of polypropylene.

70 The holder receives the disc 10 and is designed to grip the disc lightly.

The inside faces of the covers of the container, i.e. those which face each other in the closed position, are opposite to the faces provided with the grooves defining the hinges 21, 22. This arrangement permits either one of the covers (e.g. 13) to be pivotally moved from the closed position relative to the spine 12 about the adjacent hinge (21) until the cover approaches alignment with the spine. The spine then moves with the cover (13) about the other hinge (22). The holder 14, therefore, is raised by the spine away from the other cover 11, so that the disc in the holder is presented for easy removal. A partly open position is shown in Figure 1 and the fully open position is shown in Figure 3. It is not essential for the container to be opened to the degree shown in Figure 3.

85 The outer face of the sheet 20 may be pre-printed before the frames and holder are moulded on to the sheet.

90 The holder may be designed to support other articles.

The sheet could be made of card and the frames formed about the edges of the card, so that marginal edges are supported in the frames after moulding.

CLAIMS

100 1. A container comprising first and second hinged covers engageable to form an enclosure between the covers, a spine to which the first and second covers are hinged along parallel opposite edges of the spine by first and second hinges respectively, and a holder fixed to the spine and enclosed between the covers in the engaged position of the latter, whereby the covers can be disengaged and pivotally moved to an open position, the spine being pivotally movable with the first cover about the second hinge axis after the first cover has been moved a predetermined angle about the first hinge axis, whereby the holder is pivotally moved by the spine to a position angularly spaced from both covers to facilitate access to the holder.

105 2. A container according to Claim 1, where the spine is also pivotally movable with the second cover about the first hinge axis after the second cover has been moved a predetermined angle about the second hinge axis.

110 3. A container according to Claim 1 or 2, wherein the spine is movable with the first cover when the spine and the first cover are substantially in alignment.

115 4. A container according to Claim 1, 2 or 3, wherein the first and the second covers and the spine are all defined by parts of a single sheet and the first and second hinges are defined by lines of weakness.

120 5. A container according to Claim 1 wherein the

lines of weakness are defined by grooves in a face of the sheet.

6. A container according to Claim 4 or 5, wherein the holder is moulded on to the spine defined by the sheet.

7. A container according to Claim 4, 5 or 6, wherein each cover includes a reinforcing frame moulded on to the sheet.

8. A container according to Claim 7, wherein the sheet and the reinforcing frames are made of polypropylene.

9. A container according to Claim 6, wherein the sheet and the holder are made of polypropylene.

10. A container constructed substantially as herein described with reference to the accompanying drawings.