

Feb. 13, 1951

W. G. CLEVETT

2,541,638

PADLOCK SHIELD AND SHIELDED PADLOCK ASSEMBLY

Filed April 26, 1948

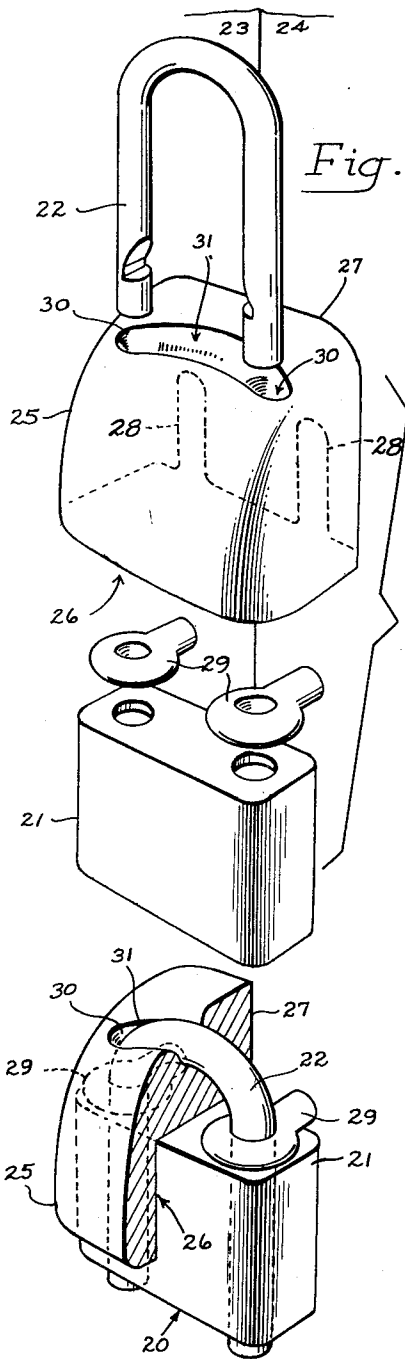

Fig. 2.

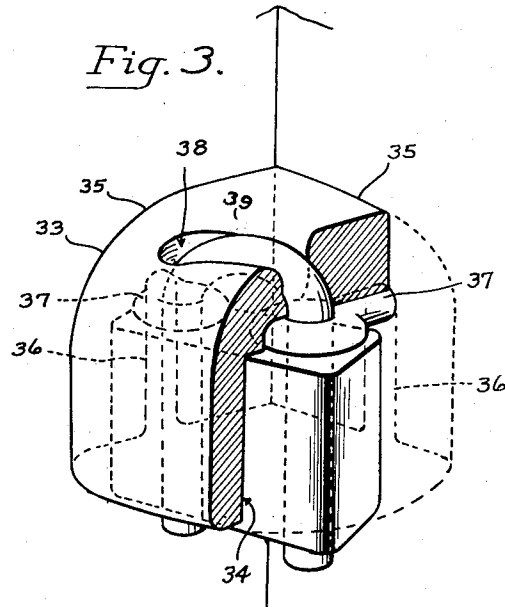

Fig. 3.

Inventor
Wallace G. Clevett
by Eugene D. Farley
Atty.

UNITED STATES PATENT OFFICE

2,541,638

PADLOCK SHIELD AND SHIELDED PADLOCK ASSEMBLY

Wallace G. Clevett, Portland, Oreg.

Application April 26, 1948, Serial No. 23,173

11 Claims. (Cl. 70—56)

1

The present invention relates to shields for protecting padlocks from tampering, and to shielded and substantially tamper-proof padlock assemblies.

It is a primary object of the present invention to provide shields for covering padlocks so that the shackle and body portions thereof are not exposed and hence are not subject to damage by striking, filing, or attack with various instruments in order to open the lock.

It is another important object of the present invention to provide shielded padlock assemblies wherein the shackle is formed as a part of the shield and hence is not exposed to tampering.

It is still another object of the present invention to provide padlock shields which are adaptable for use with padlocks of varying size, type and construction.

Another object of the present invention is the provision of padlock shields and shielded padlock assemblies which are adaptable for use in various types of installation.

Still a further object of the present invention is the provision of padlock shields and shielded padlock assemblies which are of strong but inexpensive construction, and of modern design.

The manner in which the foregoing and other objects of the present invention are accomplished will be apparent from the following specification and claims considered together with the accompanying drawings wherein:

Figure 1 is a view in elevation of a padlock shield and a shielded padlock assembly of the invention in an embodiment suitable for use with sliding shackle padlocks, the padlock assembly being in open or unlocked position;

Figure 2 is a sectional view of the shielded padlock assembly of Figure 1 in the closed or locked position; and

Figure 3 is a sectional view in elevation of a padlock shield assembly of the invention in locked position and in a form adapted for use in corner installations.

The shielded padlock assemblies of the invention broadly comprise a padlock in combination with a housing having in the interior thereof a cavity or recess adapted to contain the body of the padlock and means for affixing the housing to each of two objects to be locked together, both the affixing means and the housing being engageable with the shackle of the padlock as the latter interlocks with the padlock body. The assembly is provided in a number of different shapes and designs, adapted for use in various installations and with padlocks of various types.

The shielded padlock assemblies of the invention may be employed generally in those situa-

2

tions where padlocks customarily are used, as in locking together two movable objects or one movable object and one immovable object. Thus they may be applied to the locking together of a door abutting against a stationary casing, a pair of swinging doors, overhead doors, a receptacle having a hinged lid, and the like.

The shielded padlock assembly of the invention in the embodiments illustrated in Figures 1 to 3, inclusive, is adapted for use with sliding shackle padlocks. In the embodiment of Figures 1 and 2 such a padlock is indicated generally by the numeral 20, the body of the padlock being indicated at 21 and the shackle at 22. The padlock assembly is illustrated as being applied to the locking together of two objects 23 and 24 which may be, respectively, a door and a door casing.

The shield member of the padlock assembly comprises a housing 25 having therein a recess 26 adapted to contain the body of the padlock. The shield preferably is built from a strong constructional material such as steel or bronze and preferably is relatively thick so as to have the required strength. Its exterior may assume any desired shape as required by specific applications.

The recess 26 in the shield has dimensions and contours conforming to those of the particular padlock body it is to contain. Preferably it is sufficiently deep so that it conceals and protects all or most of the padlock body. Preferably also it fits snugly about the padlock body so as to deny access to a sharp tool or other object which might be inserted into the recess with a view to damaging the padlock.

Means are provided for affixing the housing to each of the objects to be locked together, e. g. the door and the door casing. In the embodiment illustrated in Figures 1 and 2, the housing has a flat exterior face 27 which is adapted to extend across portions of each of the objects to be locked together. In this face are a plurality of spaced slots, preferably two, 28 opening from the exterior into the recess 26, and preferably extending vertically to the base of the housing. As will be apparent to one skilled in the art, however, these slots may have a form and disposition suited to the particular affixing means employed.

Adapted to be inserted into the slots 28, 28 and having a spacing corresponding thereto are a plurality, preferably two, of eye members 29, 29, one being attached to each of the objects to be locked together. Although various forms and sizes of eye members may be employed, it suffices for the purposes of the present invention to use ordinary screw eyes, these being screwed into

3

the objects to be united sufficiently to secure them thereto, but leaving exposed a portion of the shank. It then is possible to slip the housing over the eyes, the shanks of the eyes sliding in the slots of the housing, and the eyes themselves projecting into the recess in the interior of the housing. In this manner, the housing is attached to each of the objects to be locked together, it being removable in one direction only.

Removal of the housing from the eye members and hence separation of the objects to be locked together is precluded by providing means for interlocking the housing and the eye members. This is accomplished by providing in the housing the openings 30, 30 which preferably are connected through a groove 31 and are adapted to receive the legs of the shackle 22.

Thus, as is particularly apparent from Figure 2, when the legs of the shackle have been slipped through the opening 30, 30 and through the eyes 29, 29 and engaged with the body of the padlock within the recess 26, the shackle lies buried within the groove 31 and the body of the lock is contained in the recess 26. Although it may readily be opened by using the proper key, it is protected from tampering by unauthorized persons.

In Figure 3 is illustrated a shielded padlock assembly of the invention in an embodiment similar in construction to that of Figures 1 and 2, but adapted for installation in corners. Such installations are of frequent occurrence. It is common practice, for example, to hang doors in such a manner that the door is set into the casing with the surface of the door recessed in the casing, so that it forms an angle with the inner casing members. In such a situation, a padlock shield is applicable comprising a housing 33 having therein a recess 34 and having also two adjacent, flat, exterior side faces 35, 35 which meet at an angle substantially conforming to the angle of the corner installation in which the shield is to be used. In these side faces are slots 36, 36 adapted to receive eye members 37, 37 one of which is attached to each of the objects to be fastened together and which are similar in construction and function to those illustrated in connection with Figures 1 and 2.

In addition to the slots for reception of the eye members, the housing of Figure 3 is provided with a pair of spaced openings one of which is shown at 38. These are aligned with the eye members when the latter are inserted in the slots so that the shackle may be slipped through the openings 38 and also through the eyes of the eye members before engaging the body of the padlock within the recess 34. As in the embodiment of Figures 1 and 2, the shackle-receiving openings 33 of the padlock shield of Figure 3 preferably are interconnected with a groove 39 in which the curved portion of the shackle is retained when the padlock is in closed position.

It will be apparent that the manner of use of the padlock assembly of Figure 3 is substantially the same as that described hereinabove in connection with the operation of the shielded padlock assembly of Figures 1 and 2.

There thus are provided by the present invention padlock shields and shielded padlock assemblies which are adaptable for use with padlocks of the customary types and sizes and which may be applied in a wide variety of installations. Furthermore, the shields and the shielded assemblies are of simple, durable and inexpensive construction and effectively protect the vulnera-

4

ble parts of the padlock from damage by tampering.

Having now described my invention in preferred embodiments, I claim as new and desire to protect by Letters Patent:

1. A shield for a sliding shackle padlock and a pair of eye members, each member consisting of an eye portion and a stem portion, comprising: a housing having a recess adapted to receive the body of a padlock and the eye portions of the eye members, and adapted to extend across portions of each of two objects to be locked together, the housing having a pair of spaced openings, each of which is adapted to receive the stem portion of one of the eye members, the eye members being affixed one to each of the objects to be locked together, and means adapted to secure the housing to the shackle of the padlock with the legs of the shackle extending into the recess, the shackle legs being adapted to extend through the eye portions and to be secured to the padlock body when the two eye portions are in the recess.

2. A shield for a sliding shackle padlock and a pair of eye members, each member consisting of an eye portion and a stem portion, comprising: a housing having a recess adapted to receive the body of a padlock and the eye portions of said eye members, and having a side adapted to extend across portions of each of two objects to be locked together, the side having a pair of spaced openings, each of which is adapted to receive the stem portion of one of the eye members, the eye members being affixed one to each of the objects to be locked together, and means adapted to secure the housing to the shackle of the padlock with the legs of the shackle extending into the recess, the shackle legs being adapted to extend through the eye portions and to be secured to the padlock body when the two eye portions are in the recess.

3. A shield for a sliding shackle padlock and a pair of eye members, each member consisting of an eye portion and a stem portion comprising: a housing having a recess adapted to receive the body of a padlock and the eye portions of said eye members, and having a side adapted to extend across portions of each of two objects to be locked together, said side having a pair of spaced slots each of which is adapted to receive the stem portion of one of said eye members, said eye members being affixed one to each of said objects to be locked together, and means adapted to secure said housing to the shackle of said padlock with the legs of said shackle extending into said recess, said shackle legs adapted to extend through said eye portions and to be secured to the padlock body when the two eye portions are in said recess.

4. A shield for a sliding shackle padlock and a pair of spaced eye members, each member consisting of an eye portion and a stem portion, which comprises: a housing having therein a recess adapted to receive the body of the padlock and the eye portions of the pair of eye members and having also a side face adapted to extend across portions of each of two objects to be locked together, said side face having therein a pair of spaced slots, each of said slots being adapted to receive the stem portion of one of said pair of members, said stem portions of said eye members being affixed one to each of said objects to be locked together, said housing having there-through a pair of spaced openings, said shackle adapted to extend through said openings and eye

5

portions and to be secured to the padlock body when the two eye portions are in said recess.

5. A shield for a sliding shackle padlock and a pair of spaced eye members, each member consisting of an eye portion and a stem portion, which comprises: a housing having therein a recess adapted to receive the body of the padlock and the eye portions of the pair of eye members and having also a side face adapted to extend across portions of each of two objects to be locked together, said side face having therein a pair of spaced slots, each of said slots being adapted to receive the stem portion of one of said pair of members, said stem portions of said eye members being affixed one to each of said objects to be locked together, said housing having therethrough a pair of spaced openings interconnected on the exterior surface of the housing by a groove, said shackle being adapted to nest within said groove and to extend through said openings and eye portions and to be secured to the padlock body when the two eye portions are in said recess.

6. A shield adapted for use in corner installations with a sliding shackle padlock and a pair of eye members, each member comprising an eye portion and a stem portion, said shield comprising: a housing having a recess adapted to receive the body of the padlock and the eye portions of said eye members, said housing having two sides meeting at an angle substantially conforming to the angle of the corner installation in which the shield is to be used, and adapted to extend across portions of two objects to be locked together, there being an opening in each of said sides adapted to receive the stem portion of one of said eye members, said eye members being affixed one to each of said objects to be locked together, and means adapted to secure said housing to the shackle of said padlock with the legs of said shackle extending into said recess, said shackle legs being adapted to extend through said eye portions and to be secured to the padlock body when the two eye portions are in said recess.

7. A shield adapted for use in corner installations with a sliding shackle padlock and a pair of eye members, each member comprising an eye portion and a stem portion, said shield comprising: a housing having a recess adapted to receive the body of the padlock and the eye portions of said eye members, said housing having two sides meeting at an angle substantially conforming to the angle of the corner installation in which the shield is to be used, and adapted to extend across portions of two objects to be locked together, there being an opening in each of said sides adapted to receive the stem portion of one of said eye members, said eye members being affixed one to each of said objects to be locked together, said housing having therethrough a pair of spaced openings, said shackle adapted to extend through said openings and eye portions and to be secured to the padlock body when the two eye portions are in said recess.

8. A shielded, sliding shackle padlock assembly comprising in combination: a sliding shackle padlock, a housing having therein a recess containing the body of the padlock and being adapted to receive the eye portions of a pair of spaced eye members, affixed one to each of two objects to be locked together, and having a side face adapted to extend across portions of each of said two objects, said side face having therein a pair of spaced openings through which said spaced eye members are adapted to extend into said recess, and means adapted to secure said housing to the

6

shackle of said padlock with the legs of said shackle extending into said recess, said shackle legs adapted to extend through said eye portions and to be secured to the padlock body when the two eye portions are in said recess.

9. A shielded, sliding shackle padlock assembly comprising in combination: a sliding shackle padlock, a housing having therein a recess containing the body of the padlock and being adapted to receive the eye portions of a pair of spaced eye members, affixed one to each of two objects to be locked together, and having a side face adapted to extend across portions of each of said two objects, said side face having therein a pair of spaced slots through which said pair of spaced eye members are adapted to extend into said recess, said housing having therethrough a pair of spaced openings, the shackle of the padlock extending through said openings and being adapted to extend through the eye portions of said eye members when the latter are in said recess and being secured to the padlock body.

10. A shielded, sliding shackle padlock assembly comprising in combination: a sliding shackle padlock, a housing having therein a recess containing the body of the padlock and being adapted to receive the eye portions of a pair of spaced eye members, affixed one to each of two objects to be locked together, and having a side face adapted to extend across portions of each of said two objects, said side face having therein a pair of spaced slots through which said pair of spaced eye members are adapted to extend into said recess, said housing having therethrough a pair of spaced openings interconnected by a groove on the exterior surface of the housing, the shackle of the padlock nesting within said groove and extending through said openings and through the eye portions of said eye members when the latter are in said recess.

11. A shielded, sliding shackle padlock assembly adapted for use in corner installations comprising in combination: a sliding shackle padlock, a housing having therein a recess containing the body of the padlock and being adapted to receive the eye portions of a pair of spaced eye members each of which is affixed to one of the two structural members forming the corner, said housing have two side faces meeting at an angle substantially conforming to the angle of the corner, each of said side faces having therein an opening through which one of said eye members is adapted to extend into said recess, and means adapted to secure said housing to the shackle of said padlock with the legs of said shackle extending into said recess, said shackle legs being adapted to extend through said eye portions and to be secured to the padlock body when the two eye portions are in said recess.

WALLACE G. CLEVETT.

REFERENCES CITED

The following references are of record in the file of this patent:

UNITED STATES PATENTS

Number	Name	Date
676,001	Jarvis	June 11, 1901
911,192	Zielenski	Feb. 2, 1909
924,331	Feola	June 8, 1909
1,244,404	Ankovitz	Oct. 23, 1917
1,338,131	Hendricks	Apr. 21, 1920
1,429,105	Rudy	Sept. 12, 1922
1,690,041	Sundquist	Oct. 30, 1928