

[54] WRECKER BODY

[75] Inventors: Harold F. Carr, Jr., Hixson, Tenn.; David F. Humphries, Lafayette, Ga.

[73] Assignee: Dover Corporation, Chattanooga, Tenn.

[**] Term: 14 Years

[21] Appl. No.: 918,940

[22] Filed: Jun. 26, 1978

[51] Int. Cl. D12-13

[52] U.S. Cl. D12/14; D12/98

[58] Field of Search D12/14, 96, 97, 91, D12/98; 280/402; 254/139.1; 212/8 R, 59 R; 414/563

[56] References Cited

U.S. PATENT DOCUMENTS

D. 222,449	10/1971	Wegener et al.	D12/96
D. 252,921	9/1979	Nespor	D12/14
2,951,601	9/1960	Castoe	414/563

OTHER PUBLICATIONS

Motor Trend, 5/76, p. 53, Mini Pickup Truck, bottom right side of page.

Primary Examiner—James M. Gandy
Attorney, Agent, or Firm—Alan Ruderman

[57] CLAIM

The ornamental design for a wrecker body, substantially as shown.

DESCRIPTION

FIG. 1 is a rear perspective view of a wrecker body embodying our new design;
FIG. 2 is a side elevational view of one side thereof;
FIG. 3 is a side elevational view of the other side thereof;
FIG. 4 is a top plan view thereof;
FIG. 5 is a front end elevational view thereof as seen from the right end of FIG. 1; and
FIG. 6 is a rear end elevational view thereof as seen from the left end of FIG. 1.

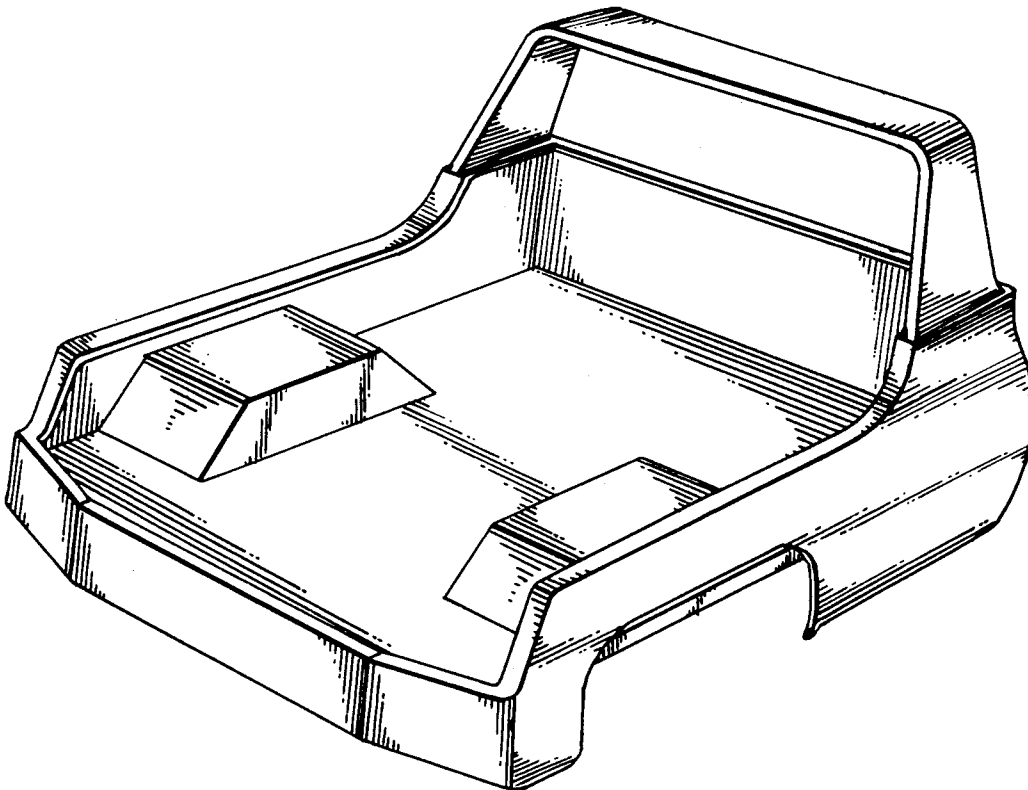

Fig. 1

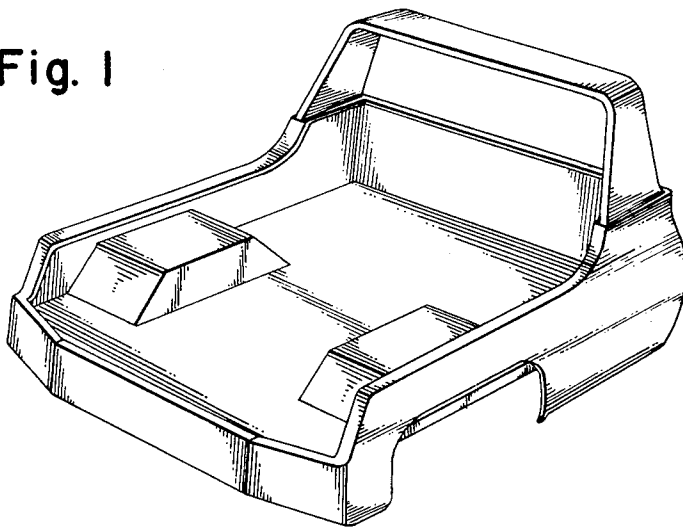
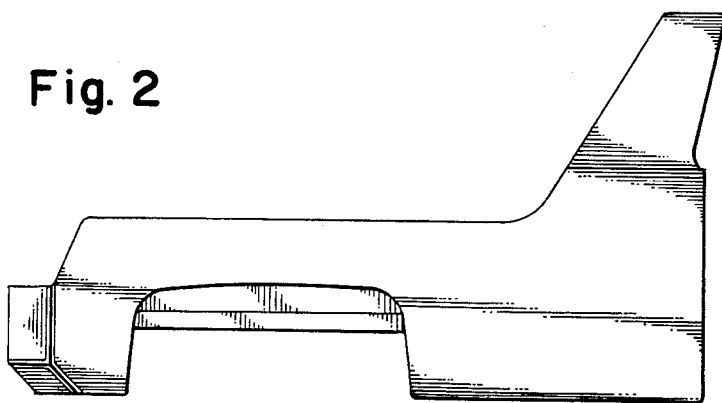

Fig. 2



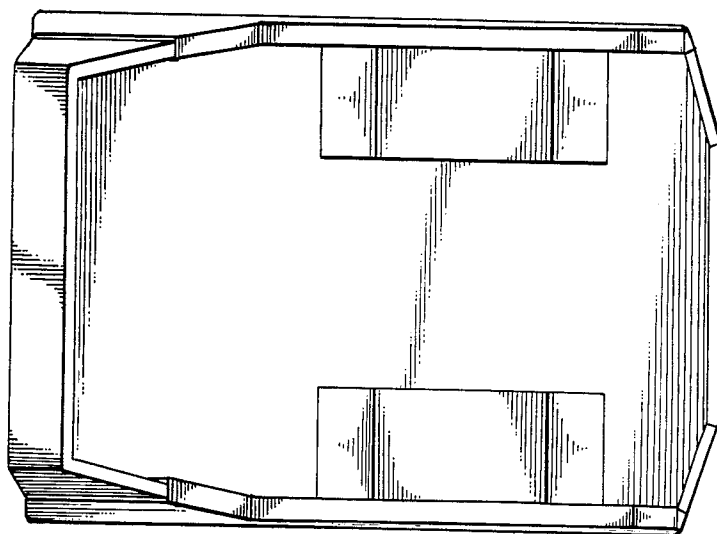

Fig. 4

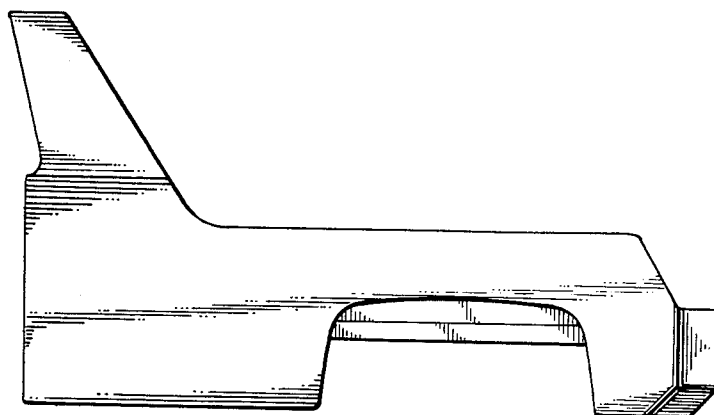

Fig. 3

Fig. 5

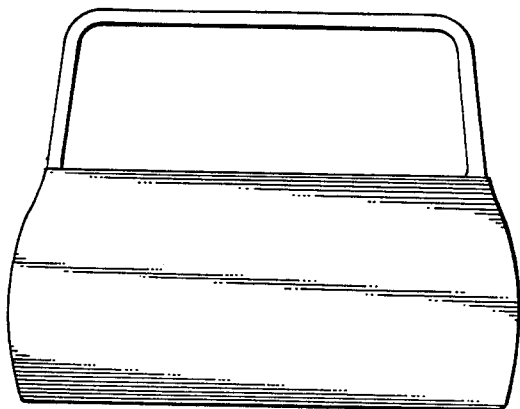

Fig. 6

