

(No Model.)

B. C. BATCHELLER.  
DRIER.

No. 486,806.

Patented Nov. 22, 1892.

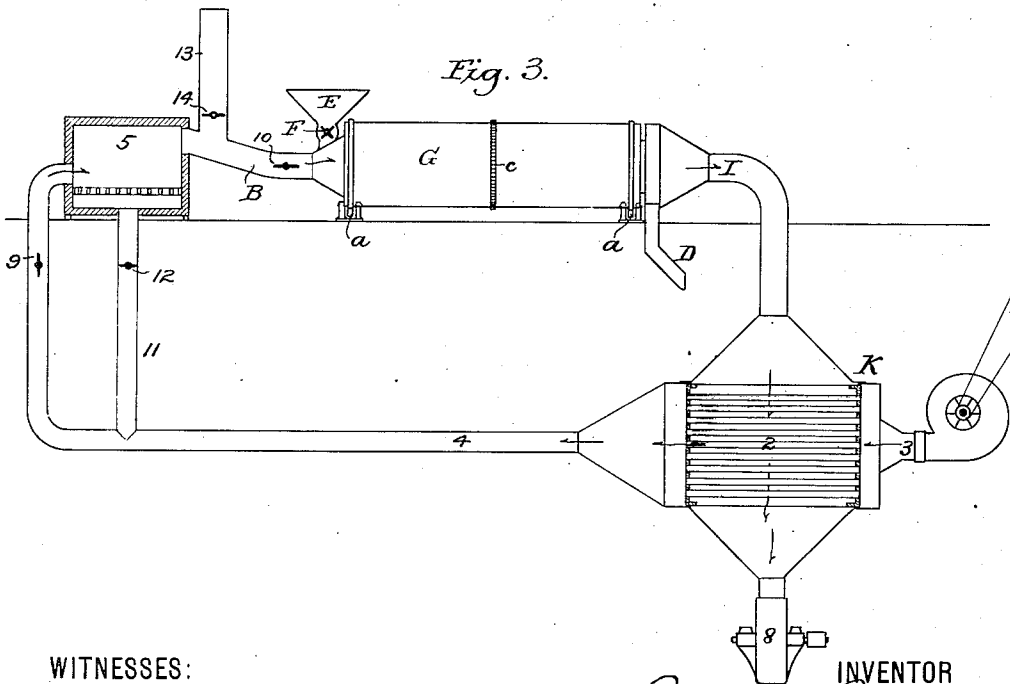
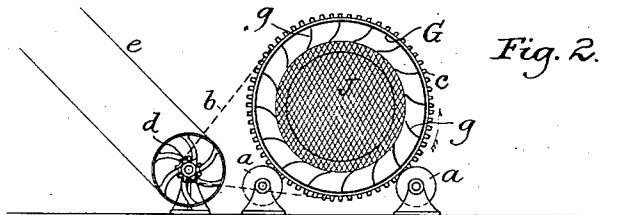
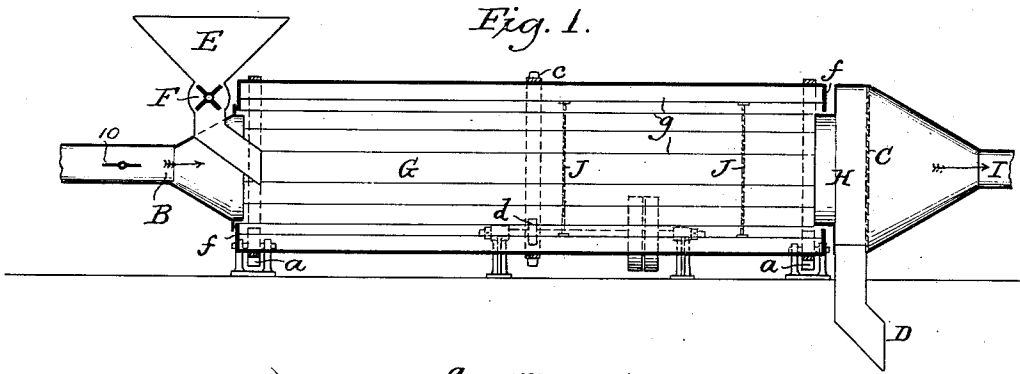

WITNESSES:

*N. Marble*  
*W. H. Graham*

INVENTOR  
*Birney C. Batcheller*  
BY  
*W. H. Graham*  
ATTORNEY

# UNITED STATES PATENT OFFICE.

BIRNEY C. BATCHELLER, OF NEW YORK, N. Y., ASSIGNOR OF SEVENTEEN-TWENTIETHS TO SPENCER D. SCHUYLER, OF SAME PLACE, AND WILLIAM M. CRAMP, OF PHILADELPHIA, PENNSYLVANIA.

## DRIER.

SPECIFICATION forming part of Letters Patent No. 486,806, dated November 22, 1892.

Application filed May 11, 1892. Serial No. 432,559. (No model.)

*To all whom it may concern:*

Be it known that I, BIRNEY C. BATCHELLER, of the city, county, and State of New York, have invented certain new and useful Improvements in Driers, fully set forth in the following description and represented in the accompanying drawings.

This invention relates to an apparatus for drying material such as brewers' grains, although it is applicable to the drying of other material.

The improved apparatus consists, substantially, of a cylinder or drum provided internally with a number of longitudinally-extending and radially-projecting, curved blades or buckets which catch the material as it is fed into the cylinder and in the rotation thereof carry it from the lower side upward, so that the material is constantly falling or dropping in streams through the center or unoccupied space of the cylinder. The curved formation of the radial buckets serves to hold the drying material until it reaches substantially the top of the cylinder, so that the material is discharged through the central space of the cylinder, in which the hottest current of air occurs. At one end of this cylinder there is provided a feeding-hopper for receiving the material to be dried and feeding it in desired quantities into the cylinder. At the same end the cylinder is connected with a hot-air-supply conduit, which leads hot air, preferably heated to a high temperature, into the cylinder, so that the current is directed lengthwise through the cylinder to become intimately mingled with the material that is constantly falling or dropping in the cylinder and carry the material as it becomes dried progressively forward to the opposite end of the cylinder, where the material is discharged and the spent air and moisture conducted onward or escaping.

With this drying apparatus there is combined means for utilizing the spent air for raising the temperature of the air to be subsequently raised to a high temperature for use in the drying apparatus.

With this general description of the apparatus a detailed description thereof will now

be given, reference being had to the accompanying drawings, in which—

Figure 1 is a longitudinal sectional elevation of the improved drier. Fig. 2 is a vertical cross-section on the line 2-2 of Fig. 1. Fig. 3 is a diagram of an apparatus employed in connection with the drier for utilizing the spent air and in heating the air for use in the drier.

Referring to Figs. 1 and 2, it is to be understood that the drier consists of a cylinder or drum G of suitable diameter and length supported horizontally to rotate on wheeled bearings *a*, driven in any suitable manner, as by a sprocket chain or belt *b*, engaging with a toothed ring *c* on the cylinder, and a sprocket-pinion on a driving-shaft *d*, driven by a belt passing around a pulley secured to said shaft. The cylinder is substantially an open-ended cylinder, but is preferably provided at each end with a continuous ledge of substantially the width of the buckets or blades with which the cylinder is provided, as hereinafter described, so that the openings at each end of the cylinder are restricted in size and the material is prevented from premature discharge. The cylinder is provided internally with a number of longitudinally-extending blades or buckets *g*, projecting inwardly toward the center of the cylinder, and are preferably curved in cross-section, so as to form a number of pockets, which catch the material and elevate it and constantly discharge it through the center or unoccupied space of the cylinder, so that it passes through the hottest portion of the air-current. At the entrance end of the cylinder there is provided a means for feeding the material into the cylinder, consisting of a hopper E to receive the material, and which hopper terminates in a spout extending into the cylinder. At the bottom of the hopper there is provided a rotary feeder F, moved by a belt passing around a pulley on the end of the shaft and driven from any proper source of power by which the material is fed in suitable quantities into the cylinder, the speed of rotation of which feeder will be governed by the kind of material being operated upon and the dry-

ing effect of the air-current through the cylinder, it being preferred in the case of brewers' grain to feed them in a thin stream, so that the hot air will immediately cake the exterior of each individual grain. This primary function of the highly-heated air is of great importance, in that it immediately acts to preserve and confine the watery substances within the grains, preventing their waste by accumulation on and caking or coating the interior of the drying-cylinder, which would otherwise require constant cleaning. This same end of the cylinder is in communication with a hot-air conduit B, terminating in a funnel increasing in size to the diameter of the opening into the end of the cylinder, with which opening the end of the funnel registers, the funnel being stationary with respect to the rotations of the cylinder.

At the opposite end of the drying-cylinder there is provided a discharge-chamber H, stationary with respect to the rotation of the drying-cylinder and registering with the opening at that end of the cylinder. This discharge-chamber is provided with an outlet D for the dried material and a conical extension I for leading off the hot or spent air from the apparatus, the chamber being separated from said conical extension by a screen C of suitable material—such as fine wire-cloth—to stop the further movement of the dried material as it is carried from the drying-cylinder by the current of air. At one or more places intermediate of the ends of the cylinder there is preferably arranged an impeding or delay screen J of wire-cloth, so that the forward movement of the material in the current of hot air is temporarily stopped and thrown down, so as to pass said screen between its outer edges and walls of the cylinder.

In the operation of the apparatus as thus constructed the material—such as brewers' grains—is fed from the feed-hopper in suitable quantities in a thin stream by the rotation of the feeder into the entrance end of the cylinder, so that it falls onto or into the blades or buckets *g*. A current of highly-heated air at approximately a temperature of 700° Fahrenheit and under more or less pressure is allowed to pass or is forced or drawn into the entrance end of the cylinder and thence longitudinally through it and out by the extension I. The cylinder is constantly rotated by the connections heretofore described, so that the grains caught by the buckets are carried partially around with the cylinder and kept constantly dropping or falling in streams through the central unoccupied portion of the cylinder across the hottest portion of the current of highly-heated air. In this way the wettest material is dropped in the presence of the hottest air and in the hottest part of the drying-cylinder and the drier grains or dried grains are successively dropped in a gradually-decreasing temperature, so that the liability of scorching or overheating is prevented. As the grains are being con-

stantly dropped and falling across the current of heated air those grains that are driest, and hence lighter than those that carry more moisture, will be carried forward and onward by the current of heated air toward the discharging end of the cylinder and into the discharge-chamber H. The direct discharge of these drier or dried grains may be impeded or delayed one or more times by the impeding-screens J, which allow the material to pass onward, but compel the material to pass to one side to be dropped possibly again, so that it may ultimately pass the outer edge of the screen or screens to be again dropped in the presence of the current of air, and being sufficiently dried will be carried by the current of air out of the drying-cylinder into the discharge-chamber H, where, meeting the stopping-screen C, it will fall into the outlet D to be removed from the apparatus for use.

From the foregoing it will be understood that the method of drying herein employed consists in constantly dropping the material to be dried across a current of highly-heated air, the material being ultimately carried onward by the current as it loses more and more of its moisture, and becoming finally and wholly carried to a point where it may be separated from the current. The method further consists in presenting the wettest material to the hottest air, whereby such heat is expended in absorbing the moisture on the exterior of the grains and caking the glutinous film, enveloping them so that the watery substances are immediately confined within the grains and saved, the air being thereby gradually cooled, and such cooler air, meeting the drier material, is prevented from scorching or overdrying it.

By the use of this improved method the nutritious substances are saved and discharged with the husks instead of being wasted or reduced to a mass by leaving the husks and coating the interior of the drying-cylinder. The apparatus hereinbefore described perfectly carries out this method, in that the hottest air and wettest material both enter the same end of the drying-cylinder, while the cooler air and the dried material likewise both pass from the cylinder at its opposite end, and it is to be understood that, while there is shown a single drying-cylinder, it is obvious that two or more cylinders may be used, through which the heated air and material will pass successively before being finally discharged.

No claim is herein made to the method of drying brewers' grains herein referred to, as the same forms the subject-matter of an application filed by me as a division of the present one.

In Fig. 3 there is shown an apparatus in connection with the drying-cylinder for utilizing the spent air, leaving the drying-cylinder for heating the incoming air on its way to the furnace to be highly heated. Thus

the extension I is continued on in communication with the interior of a heater K through the tubes 2, of which cold air is passing from the entrance 3 along a conduit 4 to a furnace 5. The spent hot air from the drying-cylinder, passing around these air-tubes, heats them, so that the cold air in passing through the tubes becomes heated before passing to the furnace. The spent hot air may be drawn through the heater by a blower 8 and discharged into the air. The fresh air now heated passes by the conduit 4 upward past a valve 9 through the furnace, and becoming highly heated passes thence into the hot-air conduit B, which may also be provided with a valve 10. The conduit 4 may have a branch conduit 11 leading to the bottom of the furnace beneath the grate, so as to supply the heated air to the fire, and this branch conduit may have a valve 12. The hot-air conduit is in communication with a stack or chimney 13, having a valve 14 therein, by which after the fire in the furnace has become sufficiently ignited the stack may be closed. This arrangement of apparatus, in connection with the drying-cylinder, provides an economical method of raising the temperature of fresh air before it passes to the furnace to be heated to the required degree for use in the drying-cylinder, and after passing to the drying-cylinder the spent hot air will be utilized to raise the temperature of the incoming fresh air.

What is claimed is—

35 1. The herein-described horizontal and rc-

tating drying-cylinder, having longitudinally arranged buckets and an exit-opening at one end concentric with the circumference of the cylinder and of less diameter than the cylinder, whereby a continuous end ledge is provided to prevent the premature discharge of the partially-dried material, and a hot-air supply leading to the opposite end of the cylinder, whereby the hot current passing through the cylinder carries the dried material out through said restricted exit-opening.

2. The combination, with a horizontally arranged and rotating cylinder, of a hot-air conduit in communication with one end of the cylinder, a material-feeder at the same end of the cylinder, and one or more impeding or delay screens within the cylinder, substantially as described.

3. The combination, with a horizontally arranged and rotating cylinder, of a hot-air conduit in communication with one end of the cylinder, a material-feeder at the same end of the cylinder, an exit extension upon the opposite end of the cylinder, having at said end a discharge-outlet for the grains and for the air, and a stopping-screen at the exit for separating the discharged grain from the air-current, substantially as described.

In witness whereof I have signed my name, in the presence of two witnesses, this 4th day of September, 1891.

BIRNEY C. BATCHELLER.

Witnesses:

HENRY RAMEY,  
S. W. POTTS.