

J. FARMER.

APPARATUS FOR DRYING AND PULVERIZING BLOOD, &c., FOR FERTILIZERS.

No. 299,766.

Patented June 3, 1884.

FIG. 1.

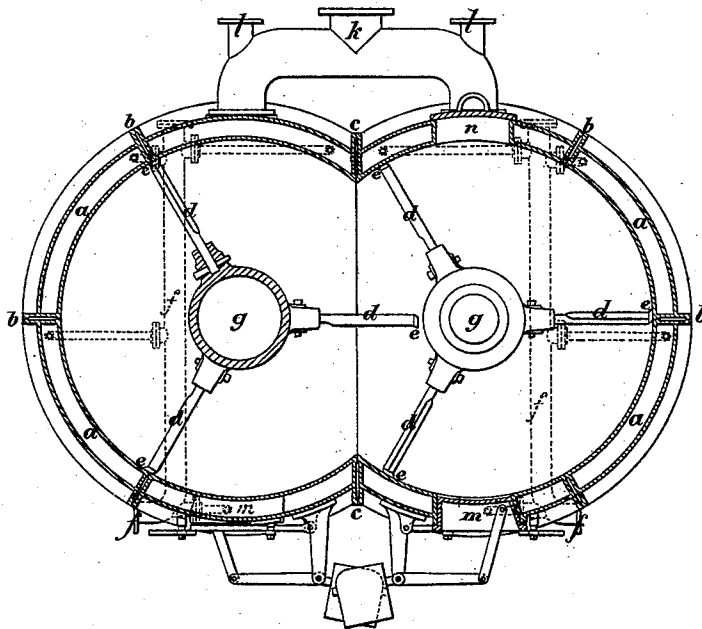

Witnesses.

Harry Drury
James I. John

Inventor.

James Farmer.
By his Attys.
Howson and Ford

J. FARMER.

APPARATUS FOR DRYING AND PULVERIZING BLOOD, &c., FOR FERTILIZERS.

No. 299,766.

Patented June 3, 1884.

FIG. 2.

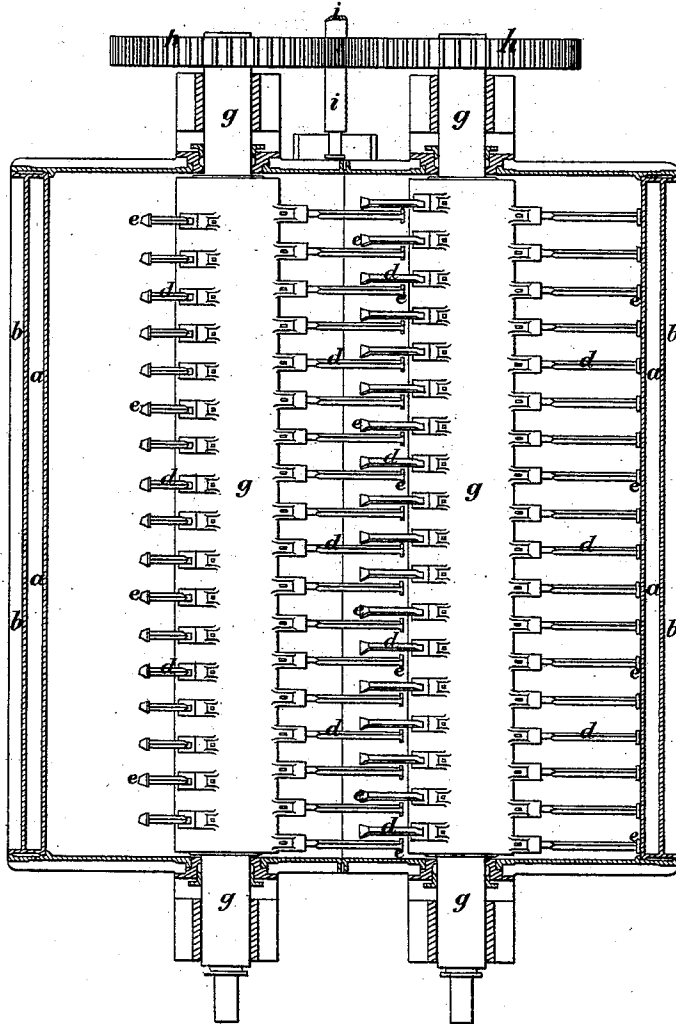

Witnesses.

Harry Drury
James F. Tobin

Inventor.

James Farmer
By his Atty.
Howson and Fry

UNITED STATES PATENT OFFICE.

JAMES FARMER, OF SALFORD, COUNTY OF LANCASTER, ENGLAND.

APPARATUS FOR DRYING AND PULVERIZING BLOOD, &c., FOR FERTILIZERS.

SPECIFICATION forming part of Letters Patent No. 299,766, dated June 3, 1884.

Application filed December 26, 1882. (No model.) Patented in England June 7, 1882, No. 2,663; in France December 7, 1882, No. 132,486, and in Germany December 9, 1882, No. 23,257.

To all whom it may concern:

Be it known that I, JAMES FARMER, a subject of the Queen of Great Britain, and residing at Salford, in the county of Lancaster, England, have invented Improvements in the Construction of Machinery or Apparatus for Drying and Pulverizing Blood, Excrementitious Matter, and other Fluid or Semi-Fluid Materials or Compounds, of which the following is a specification.

This invention relates principally to the construction of apparatus for drying and pulverizing blood and excrementitious matter, so as to form a manure-powder; but the apparatus may also be applied to the drying and pulverizing of other fluid or semi-fluid materials or compounds.

The invention consists, externally, of a fixed steam jacket or casing of a twin cylindrical form, with closed ends, in which jacket or casing are mounted two hollow steam-heated axes, each provided with a series of blades or beaters, which latter are set at varying angles, and are so arranged and geared together that when they revolve they pass between each other.

In the accompanying drawings, in which similar letters of reference indicate like parts, Figure 1 is a vertical transverse section of my improved apparatus, and Fig. 2 is a longitudinal horizontal section of the same.

The twin cylindrical steam jacket or casing *a a* is composed of two cylinders, each preferably cast-iron formed in about four sections bolted together by means of external flanges, *b b*. Each cylinder has about one-third of its circumference removed. The two open sides are placed together and united by flanges and bolts at *c c*, so that when the blades or beaters *d d* revolve upon their axes inside the two cylinders *a a* the said blades or beaters will interlock like the teeth of two spur-wheels in gear, as at Fig. 1, and break up and disintegrate the semi-dry material, preventing it from forming into large pasty lumps and being carried round by the arms, as it does in machines of one cylinder. The ends of the blades or beaters *d d* are provided with scrapers *e e*, which are so pitched around the axes and are of such a width that no two scrapers scrape or clean the same surface, but all the said scrapers in

conjunction in one revolution of each of the said axes entirely scrape or clean the inside surface of the steam-heated casing.

The accompanying drawings show the twin cylindrical steam jacket or casing, made of cast-iron in longitudinal parts or segments, to be convenient for transport and erection. The joints are planed at the right angles, and the segments are bolted together by external flanges, after which they are bored out to make a true cylindrical internal surface, enabling the scrapers to be set close to the said surface, to prevent any coating of non-conducting material from caking on the surface to retard the evaporation. Thus heat is greatly economized, and the evaporation is thereby greatly accelerated. The hollow sections *a a* are all connected together by means of branch pipes, (see dotted lines in Fig. 1,) and these branch pipes are connected to main steam-pipes *f f*. The condensed water is removed by similar pipe-connections attached to a suitable drain. The hollow axes *g g* are geared together by a pair of equal-sized spur-wheels, *h h*, (see Fig. 2,) so that they revolve in opposite directions, one of these spur-wheels being driven by a spur-pinion keyed on a shaft, *i i*, which is actuated by a steam-engine (preferably of the double-cylinder diagonal class) or by other suitable motive power. Steam is supplied to the twin cylindrical casing *a a* and also to the hollow axes, in order to heat and dry the blood or other matter under operation while it is being stirred in opposite directions by the blades or beaters *d d*. The vapor thus created is drawn through the passage *k k* by a fan or other kind of exhauster, and is sent to a condensing apparatus, which condensing apparatus forms no part of my invention. The blood or other semi-fluid matter to be operated on is poured in through openings at *l l*, and the dried manure-powder is discharged through the doors or traps *m m*. There is also a man-hole at *n n* in one of the cylinders, to allow of access to the interior.

I wish it to be understood that I do not bind myself to the method of construction already explained, as I can make the hollow casing of wrought-iron with planed jump-joints and countersunk rivets, although I prefer the cast-iron bored surface on account of its accu-

racy, and because it is free from internal leakage, which often occurs in the wrought-iron casing at the rivets through expansion. I can also construct this machine with an inside cast-iron cylinder and a fixed wrought-iron casing, leaving a cavity for steam-heating.

I am aware that it has been proposed to construct a clay-reducer with a pair of armed drums in a twin cylindrical casing, and that it is not new to combine a pair of hollow revolving drums with heaters in a jacketed tank; but I believe it be new to construct the jacketed casing of the twin cylindrical form shown, and to combine therewith the described arrangement of scrapers to keep the entire inner surface of the jacketed tank clean. If the inner surface of the steam-casing were not thus kept clean, it would become quickly corroded and coated with the material under treatment, and, as this is a non-conductor, the temperature would be considerably lowered and the

rapidity of the process seriously interfered with. The twin cylindrical form of the casing presenting no corners for the accumulation of the material greatly aids the action of the scrapers.

I claim as my invention—

The combination of a jacketed casing of a twin cylindrical form with a pair of revolving beaters having scrapers in contact with the interior surface of the casing and differently pitched around the axes, substantially as described, whereby all the scrapers in conjunction in one revolution entirely scrape the inside surface of the casing.

In testimony whereof I have signed my name to this specification in the presence of two subscribing witnesses.

JAS. FARMER.

Witnesses:

GEORGE DAVIES,
JNO. HUGHES.