

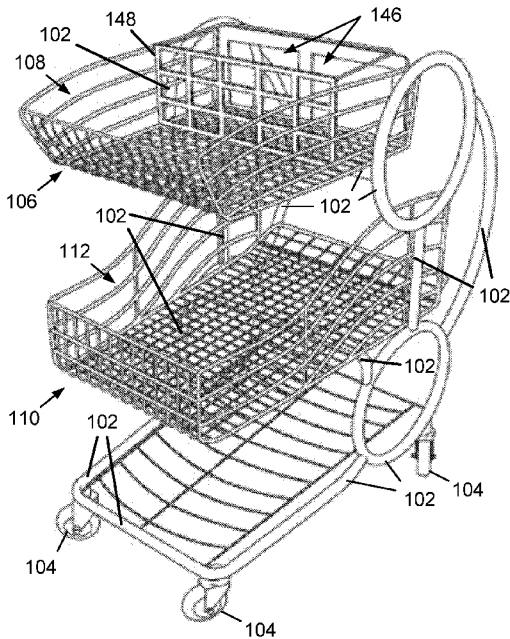

- (51) International Patent Classification: *B62B 3/14* (2006.01)
- (21) International Application Number: PCT/US2016/019206
- (22) International Filing Date: 23 February 2016 (23.02.2016)
- (25) Filing Language: English
- (26) Publication Language: English
- (30) Priority Data: 62/119,363 23 February 2015 (23.02.2015) US
- (71) Applicant: ZIBRA, LLC [US/US]; 172 Broad Sound Place, Mooresville, NC 28117 (US).
- (72) Inventors: SHERMAN, Michael, Milton; 172 Broad Sound Place, Mooresville, NC 28117 (US). BALL, William, Lane; 641 Snow Creek Road, Statesville, NC 28625 (US).
- (74) Agents: TILLMAN, Chad et al.; Tillman Wright, PLLC, P.O. Box 49309, Charlotte, NC 28277 (US).
- (81) Designated States (unless otherwise indicated, for every kind of national protection available): AE, AG, AL, AM, AO, AT, AU, AZ, BA, BB, BG, BH, BN, BR, BW, BY, BZ, CA, CH, CL, CN, CO, CR, CU, CZ, DE, DK, DM, DO, DZ, EC, EE, EG, ES, FI, GB, GD, GE, GH, GM, GT, HN, HR, HU, ID, IL, IN, IR, IS, JP, KE, KG, KN, KP, KR, KZ, LA, LC, LK, LR, LS, LU, LY, MA, MD, ME, MG, MK, MN, MW, MX, MY, MZ, NA, NG, NI, NO, NZ, OM, PA, PE, PG, PH, PL, PT, QA, RO, RS, RU, RW, SA, SC, SD, SE, SG, SK, SL, SM, ST, SV, SY, TH, TJ, TM, TN, TR, TT, TZ, UA, UG, US, UZ, VC, VN, ZA, ZM, ZW.
- (84) Designated States (unless otherwise indicated, for every kind of regional protection available): ARIPO (BW, GH, GM, KE, LR, LS, MW, MZ, NA, RW, SD, SL, ST, SZ, TZ, UG, ZM, ZW), Eurasian (AM, AZ, BY, KG, KZ, RU, TJ, TM), European (AL, AT, BE, BG, CH, CY, CZ, DE, DK, EE, ES, FI, FR, GB, GR, HR, HU, IE, IS, IT, LT, LU, LV, MC, MK, MT, NL, NO, PL, PT, RO, RS, SE, SI, SK,

[Continued on next page]

(54) Title: SHOPPING CART APPARATUS



100

FIG. 1

(57) Abstract: A cart includes a chassis and attached wheels; an upper basket attached to the chassis; and a lower basket attached to the chassis. In some embodiments, the cart includes no widthwise push bar in a rear of the cart such that access is unobstructed to the upper and lower baskets from the rear of the cart by a person. In some embodiments, the chassis defines on each lateral side of the cart a pair of vertically spaced handles, each handle surrounding and defining an opening. The handles preferably include handle bars shaped in an oval. On each cart side a curved elongate member extends between and connects the handles, and the curved elongate members represent the rearmost part of the cart. The rear area of the upper basket defines a seat for an infant, and a rear ledge of the lower basket defines a seat for a toddler.

WO 2016/138048 A1



SM, TR), OAPI (BF, BJ, CF, CG, CI, CM, GA, GN, GQ, GW, KM, ML, MR, NE, SN, TD, TG).

— before the expiration of the time limit for amending the claims and to be republished in the event of receipt of amendments (Rule 48.2(h))

**Published:**

— with international search report (Art. 21(3))

## SHOPPING CART APPARATUS

### COPYRIGHT STATEMENT

[001] All of the material in this patent document is subject to copyright protection under the copyright laws of the United States and other countries. The copyright owner has no objection to the facsimile reproduction by anyone of the patent document or the patent disclosure, as it appears in official governmental records but, otherwise, all other copyright rights whatsoever are reserved.

### BACKGROUND OF THE INVENTION

[002] The present invention generally relates to carts and, more particularly, to shopping carts.

[003] It is believed that few, if any, improvements have been made to the shopping cart in recent decades. Consequently, it is believed that the time has come for new improvements to carts in general, and such shopping carts in specific. One or more aspects and features of the present invention are believed to represent such an improvement.

### SUMMARY OF THE INVENTION

[004] The present invention includes many aspects and features. Moreover, while many aspects and features relate to, and are described in, the context of shopping, the present invention is not limited to use only in shopping, as will become apparent from the following summaries and detailed descriptions of aspects, features, and one or more embodiments of the present invention.

[005] Accordingly, in an aspect of the invention, a cart includes a chassis; wheels attached to the chassis; an upper basket attached to the chassis and defining an upper cargo area for receiving articles for transport on the cart; and a lower basket attached to the chassis and defining a lower cargo area for receiving articles for transport on the cart.

[006] In a feature of this aspect, the cart comprises a shopping cart.

[007] In a feature of this aspect, one or both of the baskets each comprises a compartment divider for forming a plurality of compartments in the cargo area of the basket for separating articles placed in the basket. In a further related feature, the one or more dividers each is selectively transitionable between an upright position, in which the divider compartmentalizes the cargo receiving area, and a stowed position, in which the divider does not compartmentalize the cargo receiving area.

[008] In a feature of this aspect, one or both of the baskets each comprises a wire basket.

[009] In a feature of this aspect, one or both of the baskets each comprises a wire grid defining a bottom of the basket. In additional related features, both baskets each comprises a wire grid defining a bottom of the basket, with the grid of the upper basket defining smaller openings between wires than that defined by the grid of the lower basket. In another additional related feature, the wire grid bends to extend upwardly at the front of the basket to further define a front wall of the basket.

[010] In a feature of this aspect, one or both of the baskets each comprises lengthwise wires at least some of which extend in generally parallel, spaced relation to define a side wall of the basket.

[011] In a feature of this aspect, the upper basket is cantilevered over the lower basket. In an additional related feature, the chassis comprises a widthwise support member on which the upper

basket is cantilevered over the lower basket. In some embodiments, such widthwise support member is the only part of the chassis that extends the width of the cart underneath and in engagement with the upper basket and that is directly connected to and directly supports the upper basket in its cantilevered position over the lower basket.

[012] In a feature of this aspect, the cart further comprises a rack located under the lower basket. The rack preferably comprises a wire framework that is bounded at the front and sides by the chassis, including a portion of the chassis that defines a U-shaped bottom bumper of the cart that extends around the front and part of the sides of the bottom of the cart. In an additional related feature, the lower basket is cantilevered over the rack, and the chassis comprises a widthwise support member on which the lower basket is cantilevered over the rack. In some embodiments, such widthwise support member is the only part of the chassis that extends the width of the cart underneath and in engagement with the lower basket and that is directly connected to and directly supports the lower basket in its cantilevered position over the rack.

[013] In a feature of this aspect, the wheels include a pair of front wheels and a pair of back wheels. In an additional related feature, each wheel of the two pair of wheels swivel 360 degrees. In an alternative additional related feature, each of the pair of front wheels swivel 360 degrees, and neither of the pair of back wheels swivels.

[014] In a feature of this aspect, the cart is designed and configured to nest with other like carts. In an additional related feature, the nesting is accomplished by pushing the front of a first one of the carts into the rear of a second one of the carts such that the upper basket of the first cart is received within the upper basket of the second cart, and the lower basket of the first cart is received within the lower basket of the second cart. When nesting, a rear wall of the upper basket of the second cart preferably collapses in response to the front of the upper basket of the first cart being pushed there against, and a rear wall of the lower basket of the second cart preferably collapses in response to the front of the lower basket of the first cart being pushed there against.

[015] In a feature of this aspect, the cart comprises one or more cup holders. In an additional related feature, each cup holder is attached to the chassis of the cart at the uppermost part of the cart.

[016] In a feature of this aspect, the cart comprises a latch located on or attached to a basket on a side of the cart, whereby a purse or other personal item having a strap or ring can be latched to the cart in a secure location and manner.

[017] In a feature of this aspect, the cart includes no widthwise push bar in a rear of the cart for pushing of the cart by a person such that access is unobstructed to the upper basket and to the lower basket from the rear of the cart by a person.

[018] In a feature of this aspect, the chassis comprises elongate members connected together, such as for example by welding or by being integrally connected through molding or other formation technique. The elongate members may comprise, for example, tubes having oval, rectangular, triangular, or other polygonal cross-sectional profiles, as well as combinations thereof. Still yet, in

some embodiments the chassis consists of such elongate members connected together. The elongate members further may be bent.

[019] In a feature of this aspect, the chassis defines areas on opposite lateral sides of the cart for gripping and pushing the cart by a person when standing at the rear of the cart. These areas of the chassis preferably are curved. In an additional related feature, the chassis defines on each of the opposite lateral sides of the cart a pair of vertically spaced handles, wherein each handle surrounds and defines an interior opening area. In this respect, each handles may comprise a handle bar shaped in an oval, and the interior opening area can be used for promotional space. Furthermore, one or more elongate members of the chassis on each side of the cart extend between and connect the handles. In some embodiments including such features, the handles and an elongate member connecting the handles on a lateral side of the cart define the shape of armless spectacles. In some embodiments including such features, such elongate member is curved and in the shape of an arc in extending between the handles, with such elongate member extending beyond the rear of the upper basket and the rear of the lower basket so as to define the rearmost part of the cart. Furthermore, in some embodiments including such features, the handles on each side are vertically located over a wheel of the cart.

[020] In a feature of this aspect, the rear area of the upper basket preferably defines a seat for an infant.

[021] In a feature of this aspect, the lower basket defines a seat at a rear area thereof for a toddler. In an additional related feature, a rear wall of the lower basket moves away so that the rear area including a resulting rear edge of the lower basket is used as a ledge for sitting of the toddler. Additionally, the rear of the upper basket is horizontally offset toward the front of the cart relative to the rear of the lower basket so as to provide clearance by which a toddler sits up when seated on the rear ledge of the lower basket.

[022] Yet another aspect comprises making a cart in accordance with one or more of the foregoing aspects and features.

[023] Another aspect comprises using a cart in accordance with one or more of the foregoing aspects and features.

[024] In addition to the aforementioned aspects and features of the present invention, it should be noted that the present invention further encompasses the various possible combinations and subcombinations of such aspects and features. Thus, for example, any aspect may be combined with an aforementioned feature in accordance with the present invention without requiring any other aspect or feature.

#### BRIEF DESCRIPTION OF THE DRAWINGS

[025] One or more preferred embodiments of the present invention now will be described in detail with reference to the accompanying drawings.

[026] FIG. 1 is a perspective front left view of a cart in accordance with an embodiment of the present invention.

[027] FIG. 2 is a perspective view of the front of the cart of FIG. 1.

[028] FIG. 3 is a perspective front right view of the cart of FIG. 1.

[029] FIG. 4 is a perspective right side view of the cart of FIG. 1.

[030] FIG. 5 is a perspective back right view of the cart of FIG. 1.

[031] FIG. 6 is a perspective view of the back of the cart of FIG. 1.

[032] FIG. 7 is a perspective back left view of the cart of FIG. 1.

[033] FIG. 8 is a perspective left side view of the cart of FIG. 1.

[034] FIG. 9 is a perspective view of the top of the cart of FIG. 1.

[035] FIG. 10 is a perspective top left front view of a cart in accordance with another embodiment of the present invention.

[036] FIG. 11 is a perspective top left side view of the cart of FIG. 10.

[037] FIG. 12 is a perspective top left back view of the cart of FIG. 10.

[038] FIG. 13 is a perspective top right back view of the cart of FIG. 10.

[039] FIG. 14 is a perspective top right side view of the cart of FIG. 10.

[040] FIG. 15 is a perspective top right front view of the cart of FIG. 10.

#### DETAILED DESCRIPTION

[041] As a preliminary matter, it will readily be understood by one having ordinary skill in the relevant art (“Ordinary Artisan”) that the present invention has broad utility and application. As should be understood, any embodiment may incorporate only one or a plurality of the above-disclosed aspects of the invention and may further incorporate only one or a plurality of the above-disclosed features. Furthermore, any embodiment discussed and identified as being “preferred” is considered to be part of a best mode contemplated for carrying out the present invention. Other embodiments also may be discussed for additional illustrative purposes in providing a full and enabling disclosure of the present invention. As should be understood, any embodiment may incorporate only one or a plurality of the above-disclosed aspects of the invention and may further incorporate only one or a plurality of the above-disclosed features. Moreover, many embodiments, such as adaptations, variations, modifications, and equivalent arrangements, will be implicitly disclosed by the embodiments described herein and fall within the scope of the present invention.

[042] Accordingly, while the present invention is described herein in detail in relation to one or more embodiments, it is to be understood that this disclosure is illustrative and exemplary of the present invention, and is made merely for the purposes of providing a full and enabling disclosure of the present invention. The detailed disclosure herein of one or more embodiments is not intended, nor is to be construed, to limit the scope of patent protection afforded the present invention in any claim of a patent issuing here from, which scope is to be defined by the claims and the equivalents thereof.

It is not intended that the scope of patent protection afforded the present invention be defined by reading into any claim a limitation found herein that does not explicitly appear in the claim itself.

[043] Thus, for example, any sequence(s) and/or temporal order of steps of various processes or methods that are described herein are illustrative and not restrictive. Accordingly, it should be understood that, although steps of various processes or methods may be shown and described as being in a sequence or temporal order, the steps of any such processes or methods are not limited to being carried out in any particular sequence or order, absent an indication otherwise. Indeed, the steps in such processes or methods generally may be carried out in various different sequences and orders while still falling within the scope of the present invention. Accordingly, it is intended that the scope of patent protection afforded the present invention is to be defined by the issued claim(s) rather than the description set forth herein.

[044] Additionally, it is important to note that each term used herein refers to that which the Ordinary Artisan would understand such term to mean based on the contextual use of such term herein. To the extent that the meaning of a term used herein—as understood by the Ordinary Artisan based on the contextual use of such term—differs in any way from any particular dictionary definition of such term, it is intended that the meaning of the term as understood by the Ordinary Artisan should prevail.

[045] Regarding applicability of 35 U.S.C. 112, subsection (f), no claim element is intended to be read in accordance with this statutory provision unless the explicit phrase “means for” or “step for” is actually used in such claim element, whereupon this statutory provision is intended to apply in the interpretation of such claim element.

[046] Furthermore, it is important to note that, as used herein, “a” and “an” each generally denotes “at least one,” but does not exclude a plurality unless the contextual use dictates otherwise. Thus, reference to “a picnic basket having an apple” describes “a picnic basket having at least one apple” as well as “a picnic basket having apples.” In contrast, reference to “a picnic basket having a single apple” describes “a picnic basket having only one apple.”

[047] When used herein to join a list of items, “or” denotes “at least one of the items,” but does not exclude a plurality of items of the list. Thus, reference to “a picnic basket having cheese or crackers” describes “a picnic basket having cheese without crackers”, “a picnic basket having crackers without cheese”, and “a picnic basket having both cheese and crackers.” Finally, when used herein to join a list of items, “and” denotes “all of the items of the list.” Thus, reference to “a picnic basket having cheese and crackers” describes “a picnic basket having cheese, wherein the picnic basket further has crackers,” as well as describes “a picnic basket having crackers, wherein the picnic basket further has cheese.”

[048] Referring now to the drawings, one or more preferred embodiments of the present invention are next described. The following description of one or more preferred embodiments is merely exemplary in nature and is in no way intended to limit the invention, its implementations, or uses.

[049] Turning now to FIGS. 1-9, FIG. 1 is a perspective front left view of a cart **100** in accordance with an embodiment of the present invention; FIG. 2 is a perspective view of the front of the cart **100**; FIG. 3 is a perspective front right view of the cart **100**; FIG. 4 is a perspective right side view of the cart **100**; FIG. 5 is a perspective back right view of the cart **100**; FIG. 6 is a perspective view of the back of the cart **100**; FIG. 7 is a perspective back left view of the cart **100**; FIG. 8 is a perspective left side view of the cart **100**; and FIG. 9 is a perspective view of the top of the cart **100**.

[050] With particular reference to FIG. 1, the cart **100** preferably is a shopping cart that comprises a chassis **102**; wheels **104** attached to the chassis **102**; an upper basket **106** attached to the chassis **102** that defines an upper cargo area **108** for receiving articles for transport on the cart **100**; and a lower basket **110** attached to the chassis **102** that defines a lower cargo area **112** for receiving articles for transport on the cart **100**.

[051] The chassis **102** as shown consists of elongate members in the form of pipes or tubes connected together by welding and by being integrally molding together or made through other formation techniques, including bending. The elongate members as shown include generally oval cross-sectional profiles. The elongate members form different parts of the chassis, as now described in detail.

[052] In greater detail, the chassis **102** defines areas on opposite lateral sides of the cart **100** for gripping and pushing the cart by a person when standing at the rear of the cart **100**. With particular reference to FIG. 4 showing the right hand side of the cart **100** and FIG. 8 showing the left hand side of the cart **100**, such areas of the chassis **102** include a pair of vertically spaced handles on the right hand side of the cart **100**, including an upper handle **114** and a lower handle **116**; and a pair of vertically spaced handles on the left hand side of the cart **100**, including an upper handle **118** and a lower handle **120**. The handle pair on the right hand side is vertically located over a rear wheel **104**, and the handle pair on the left hand side is vertically located over the other rear wheel **104**.

[053] As further best seen in FIGS. 5 and 7, elongate members **122,124** of the chassis **102** extend between and connect the handles **114,116** on the right side of the cart **100**; and elongate members **126,128** of the chassis **102** extend between and connect the handles **118,120** on the left side of the cart **100**. Of these elongate members, elongate members **124,128** each is linear in extending between handles, and elongate members **122,126** each is curved in an arc in extending between handles and extends beyond the rear of the upper basket **106** and the rear of the lower basket **110** so as to define the rearmost part of the cart **100**.

[054] Furthermore, handles **114,116** and connecting elongate member **122** on the right hand lateral side of the cart **100** define the shape of armless spectacles, and handles **118,120** and connecting elongate member **126** on the left hand lateral side of the cart **100** define a similar shape of armless spectacles. A different shape of armless spectacles is defined by handles **114,116** and connecting elongate member **124**, and is defined by handles **118,120** and connecting elongate member **128**.



[055] It is recognized that, in practice, the upper handles of the pairs and the connecting elongate members 122,126 would be utilized in gripping, pushing, and steering the cart 100 by a person located at the rear of the cart 100, and that the lower "handle of each pair rarely, if ever, would be utilized in gripping, pushing, or steering the cart 100. The portions of the chassis 102 forming the lower handles 116,120 nonetheless are referred to as "handles" insofar as they are similar in construction and appearance to handles 114,118.

[056] It further is contemplated that, while each handle is shown to comprise a handle bar that has been shaped into an oval configuration to surround and define an interior opening area, the configuration may be polygonal in shape and that the interior opening area may be partially surrounded rather than entirely surrounded. It also is contemplated that the interior opening area of each handle be used for promotional space, as described in further detail below with reference to cart 200. It is believed that such areas do not aesthetically appear as secondary or separate from the cart design, but rather serve to fill-in and complete the cart design.

[057] Continuing with further detailed description regarding the chassis 102, and as perhaps best seen in FIG. 3, the chassis 102 comprises a generally linear, widthwise support member 130 on which the upper basket 106 is supported, and the chassis 102 comprises a U-shaped, widthwise support member 132 on which the lower basket 110 is supported. Furthermore, widthwise support member 130 extends between and connects handles 114,118; and widthwise support member 132 extends between and connects handles 116,120.

[058] As also shown in FIG. 3, the chassis 102 also includes defines a U-shaped bottom bumper 134 of the cart 100 that extends around the front and partway along the sides of the bottom of the cart 100. The cart 100 further comprises a rack 136 that is located under the lower basket 110 and that is bounded by the U-shaped bottom bumper 134 and the handles 116,120. The rack 136 comprises a wire framework including horizontal wire supports 138 that are bowed to allow for products to slide more easily onto the rack 136.

[059] From the foregoing, it will be appreciated that the upper basket 106 is cantilevered over the lower basket 110, and the widthwise support member 130 supports the upper basket 106 in its cantilevered position over the lower basket 110. Moreover, as shown, the widthwise support member 130 is the only part of the chassis 102 that extends the width of the cart 100 and is directly connected to and directly supports the upper basket 106 in its cantilevered position over the lower basket 110.

[060] Similarly, it will be appreciated that the lower basket 110 is cantilevered over the rack 136, and the widthwise support member 132 supports the lower basket 110 in its cantilevered position over the rack 136. Moreover, as shown, the widthwise support member 132 is the only part of the chassis 102 that extends the width of the cart 100 and is directly connected to and directly supports the lower basket 110 in its cantilevered position over the rack 136.

[061] Turning now the wheels 104, the cart 100 comprises four wheels 104 including a pair of front wheels 104 and a pair of back wheels 104. Each wheel 104 preferably is the same as the others and

swivels in all directions, i.e., 360 degrees. It is believed that enabling all wheels to swivel freely will prevent extensive wear and tear on wheels inside and out that is seen in conventional carts, thereby reducing maintenance. It is further believed that enabling all wheels to swivel freely will provide for easier maneuverability of the cart in stores and parking lots when nested in groups and pushed by attendants, as well as achieve smooth fluid maneuverability of the cart in a store by a shopper whether the cart is empty, partially loaded, or fully loaded. In alternative embodiment, the pair of front wheels swivel 360 degrees, but neither of the back wheels swivel thereby providing a more fixed direction when pushing the cart forward.

[062] Turning now to the baskets, the upper basket **106** is attached to the chassis **102** such as by welding and is located at an elevation of around chest height for the average shopper, while the lower basket **110** is likewise attached to the chassis **102** and is located at an elevation of around thigh height for the average shopper.

[063] As described above, the upper basket **106** is primarily supported by the single upper widthwise support member **130** that extends underneath the upper basket **106** between and is connected to the upper handles **114,118**, with the upper widthwise support member **130** being located closer to the rear of the upper basket **106** than to the front of the upper basket **106** such that the upper basket **106** cantilevers over the lower basket **110**. The upper basket **106** preferably is welded to the widthwise support member upper **130** as well as is welded along its sides to portions of the chassis **102** that are located at the sides of the cart **100**.

[064] The lower basket **110** is primarily supported on the single lower widthwise support member **132** that extends underneath the lower basket **110** between and is connected to the lower handles **116,120**, with the lower widthwise support member **132** being located closer to the rear of the upper basket **110** than to the front of the upper basket **110** such that the lower basket **110** cantilevers over the rack **136**. The lower basket **110** preferably is welded to the lower widthwise support member **132** as well as is welded along its sides to portions of the chassis **102** that are located at the sides of the cart **100**.

[065] As shown upper basket **106** comprises a wire basket having a wire grid **140** that defines a bottom of the basket upper basket **106**. Furthermore, the wire grid **140** preferably bends to extend upwardly at the front of the upper basket **106** to define a front wall of the upper basket **106**, as perhaps best seen in FIG. 9. Similarly, as shown lower basket **110** comprises a wire basket having a wire grid **142** that defines a bottom of the lower basket **110**. Furthermore, the wire grid **142** preferably bends to extend upwardly at the front of the lower basket **110** to define a front wall of the lower basket **110**, as perhaps best seen in FIG. 6.

[066] In some embodiments, the wire grid of one of the baskets, such as the upper basket, includes a tighter cross-hatching of the wire thereby defining smaller openings or interstices between the wires thereof than the openings defined by the wires of the grid of the other basket. In other embodiments the openings defined by the wires of the grid are approximately the same. In any event, it is preferred

that a sufficient opening be defined for rinsing and drying of the cart after exposure to inclement weather.

[067] The opposite lateral side walls of each basket as illustrated each comprises lengthwise wires that extend in generally parallel, spaced relation from front to back of the basket. Furthermore, the upper basket **106** is shorter in length than the lower basket **110**, with the front edges of the baskets **106,110** generally overlying one another but with the back edges of the baskets **106,110** being offset.

[068] The height between the top and bottom of the side walls of the upper basket **106** reduces in height near the front of the upper basket **106** in a direction from back to front of the cart **100**, whereby a low-profile front of the upper basket **106** is defined that accommodates loading of articles into the upper basket **106** from the front of the cart **100**. In contrast, the height between the top and bottom of the side walls of the lower basket **110** is greatest at the rear of the cart **100** and reduces in height between the rear and the front of the cart **100** in a direction from back to front of the cart **100** so as to define a sloped hill along the top of the side wall of the lower basket **110**. Furthermore, the rear height of the side wall of the lower basket **110** is visibly greater than the rear height of the side wall of the upper basket **106**. In some embodiments, the height of the side wall of the lower basket **110** in the rear is approximately 25% greater than the height of the side wall of the upper basket **106** in the rear. The height of the lower basket **110** in the rear provides greater enclosure for taller articles placed in the cargo area of the lower basket **110**.

[069] The rear area of the upper basket **106** preferably defines a seat for an infant weighing up to 35lbs. Being in the rear of the upper basket **106**, the infant is designed to be located in close proximity to the person pushing the cart. Snap-and-lock straps (now shown) preferably are included with the cart **100** for securing the infant. High side walls of the upper basket **106** in the rear area further secure the infant, providing enclosure to the infant seating area of the upper basket of the cart.

[070] With continuing reference to cart **100**, two leg openings **146** defined in the rear wall of the upper basket **106** are provided through which the legs of the infant may be extended. A gate **148** serving as a compartment divider is provided for forming two compartments in the cargo area **108** of the upper basket **106** for separating articles placed in the upper basket **106** from the infant seating area. While the gate **148** may be fixed in position to the upper basket **106** and not movable, preferably the gate **148** is connected to a bottom of the upper basket **106** for pivoting movement relative thereto, and may be attached by one or more hinges to the bottom of the upper basket **106**. Alternatively, other mechanisms can be utilized in place of the one or more hinges so long as the gate is configurable between a generally upstanding position, in which the gate **148** divides and compartmentalizes the cargo area, and a generally stowed position, in which the gate **148** does not divide and compartmentalize the cargo area. A hinged seat covering (not shown) that is pivotal on the rear wall of the upper basket **106** further may be provided for compartmentalized use of the infant seating area as an area for receiving articles when an infant is not seated there. Such a hinged seat covering is disclosed and described below with reference to cart **200**.

[071] Similar to the upper basket, the lower basket **110** also defines a seating area at a rear area thereof. The seat of the lower basket **110** preferably is designed for a toddler weighing over 35lbs rather than an infant weighing under 35lbs. In this respect, the rear wall **150** of the lower basket **110** preferably folds down onto the floor of the lower basket **110** into a flattened position. The rear wall **150** preferably is attached at a bottom edge thereof to the floor of the lower basket **110** by one or more hinges. Alternatively, other mechanisms can be utilized in place of the one or more hinges so long as the rear wall **150** is able to transition between an upward position and a folded position. When in the upstanding position, the rear wall **150** prevents articles from rolling or otherwise falling out of the lower basket **110** during shopping. Furthermore, when pushed against during nesting of carts (discussed below), the rear wall **150** collapses on impact to fold down. When the rear wall **150** is folded to the floor, the resulting edge of the lower basket **110** thereby is made available for use a ledge for sitting of a toddler. Furthermore, the horizontal offset of the rear of the upper basket **106** relative to the rear of the lower basket **110** provides the clearance by which a toddler can sit up when seated on the ledge of the lower basket **110** when the rear wall **150** thereof is folded to the floor. Such offset of the upper basket **106** to the lower basket **110** is seen in the drawings.

[072] A toddler seated in the seating area of the lower basket **110** on the ledge thereof can be secured with a snap-and-lock strap (not shown). Moreover, the height of the side wall of the lower basket **110** at the rear thereof provides significant enclosure for a toddler sitting in the seating area of and on the ledge of the lower basket **110**. It also will be appreciated that because the lower basket **110** is located substantially below the upper basket **106**, the toddler's proximity to the ground is greater than that of a toddler when placed into a large shopping basket of a traditional cart, thereby providing greater safety should the toddler fall. Moreover, it is believed that the design of the carts of the present invention discourage toddlers from being placed in the upper basket.

[073] The cart **100** is designed and configured to nest front-to-rear with other like carts. The nesting is accomplished by pushing the front of a first one of the carts into the rear of a second one of the carts such that the upper basket of the first cart is received within the upper basket of the second cart, and the lower basket of the first cart is received within the lower basket of the second cart. When nesting, a rear wall of the upper basket of the second cart collapses in response to the front of the upper basket of the first cart being pushed there against, and a rear wall of the lower basket of the second cart collapses in response to the front of the lower basket of the first cart being pushed there against. It is believed that when nested, the distance from the rear of cart to the front of the cart in which it is nested is shorter than nesting of convention shopping carts, thereby resulting in a greater number of carts that can be stored together in a given area compared to conventional carts.

[074] From the foregoing detailed description of cart **100** and corresponding drawings, it will be appreciated that the cart **100** includes no widthwise push bar in a rear of the cart for pushing of the cart by a person, as conventionally would be expected of a shopping cart. By omitting the push bar, unobstructed access by a person is provided to both the upper basket and the lower basket from the

rear of the cart. Moreover, omission of the push bar facilitates provision and use of the two seats as disclosed herein. These benefits are perhaps best seen in FIG. 6 illustrating a perspective view of the rear of the cart **100**.

[075] From the foregoing detailed description of cart **100** and corresponding drawings, it will further be appreciated that there is no push bar extending laterally across the rear of the cart by which a person might grab and push the cart. Such a push bar is believed to interfere with and otherwise impede the ease of loading of the baskets in the shelf-like system. It is believed that removal of the push bar allows for complete access to the open baskets at the rear of the cart for loading of articles into either of the baskets while shopping from the same vantage point of pushing the cart. This requires fewer steps by the person in stepping around from the rear of the cart and enables the person to better focus on shopping from one item to the next. This also makes shopping in crowded aisles easier, as a person does not have to step out from the rear of the cart to a side of the cart.

[076] It will further be appreciated that the omission of the conventional push bar allows for an easier and more natural way of steering the cart. Curved handles on each side of the cart extend between and connect respective upper ring handles and lower ring handles and are configured and dimensioned such that the curved handles extend toward opposite lateral sides of a person standing at the rear of the cart. The curved handles and upper and lower ring handles are located generally over the rear wheels of the cart. The side position of the curved handles, including the upper handle rings, allow for shoppers of any height to push the cart comfortably by gripping and pushing the cart. It further will be appreciated that gripping and steering the cart at the rear sides thereof make steering and control of the cart easier. The design also permits for full and open access to the baskets similar to shelves in a home pantry. Such an open backside also prevents steering in horizontal position, which is believed to be unnatural. People tend to walk with their hands at their sides, and pushing in such a relaxed position with their hands vertical to their sides, palms faced toward each other, is believed to be more conducive for slower pace shopping experiences.

[077] In use, the cart **100** features convenience in loading. In particular, the two baskets **106,110** are stacked in spaced, vertical relation, with the rear of the baskets being offset from one another at the rear of the cart. A person pushing the cart usually stands at the rear of the cart, and the two baskets present a shelf-like system for ease of loading of articles by the person at the rear of the cart.

[078] Turning now to FIGS. 10-15, FIG. 10 is a perspective top left front view of a cart **200** in accordance with another embodiment of the present invention; FIG. 11 is a perspective top left side view of the cart **200**; FIG. 12 is a perspective top left back view of the cart **200**; FIG. 13 is a perspective top right back view of the cart **200**; FIG. 14 is a perspective top right side view of the cart **200**; and FIG. 15 is a perspective top right front view of the cart **200**.

[079] The structure and functionality of cart **200** is similar to that of cart **100**, and therefore just the primary differences will be described for purposes of brevity.

[080] As seen in FIGS. 10-15, the cart **200** comprises one or more cup holders **252**. Each cup holder **252** is attached to a chassis of the cart **200** at the uppermost part of the cart **200**, namely, at upper handles **214,218**. Such positioning of the cup holders provides for easy placement of a drink of a shopper without the shopper being obstructive to the mechanics of operating the cart. Nor do the cup holders inhibit nesting of the carts **200**.

[081] Regarding upper basket **206**, the rear area of the upper basket **206** defines a seat for an infant weighing preferably up to 35lbs. Being in the rear of the upper basket **206**, the infant is designed to be located in close proximity to the person pushing the cart. Snap-and-lock straps (now shown) preferably are included with the cart **200** for securing the infant. High side walls of the upper basket **206** in the rear area further secure the infant. Furthermore, the widthwise elongate member **230**, which extends between the handles **214,218** in contact with the underneath of the upper basket **206**, is located closer to the rear of the upper basket than in cart **100** and, in fact, underlies the infant seating area.

[082] An opening **246** for accommodating the infant's legs is defined in the rear wall of the upper basket **206**, and a gate **248** serving as a compartment divider is provided for forming two compartments in the cargo area of the upper basket **206** for separating articles placed in the upper basket **206** from the infant seating area. While the gate **248** may be fixed in position to the upper basket **206** and not movable, preferably the gate **248** is connected to a bottom of the upper basket **206** for pivoting movement relative thereto, and may be attached by one or more hinges to the bottom of the upper basket **206**. Alternatively, other mechanisms can be utilized in place of the one or more hinges so long as the gate is configurable between a generally upstanding position, in which the gate **248** divides and compartmentalizes the cargo area, and a generally stowed position, in which the gate **248** does not divide and compartmentalize the cargo area. A hinged seat covering **254** also is provided that is pivotal on the rear wall or floor of the upper basket **206** and further may be provided for compartmentalized use of the infant seating area as an area for receiving articles when an infant is not seated there; such hinged seat covering **254** prevents articles from falling through the leg opening **246**.

[083] An additional gate **256** is provided that serves to compartmentalize the cargo area of the upper basket **206** for separating articles placed in the upper basket **206**. The gate **256** preferably lifts and slides in place to provide adequate compartmentalization of articles, facilitating for example grocery grouping. The gate **256** may be connected to a bottom of the upper basket **206** for pivoting movement relative thereto. In this respect, the gate **256** may be attached by one or more hinges to the bottom of the upper basket **206**. Alternatively, other mechanisms can be utilized in place of the one or more hinges so long as the gate **256** is configurable between a generally upstanding position, in which the gate further divides and compartmentalizes the cargo area of the upper basket **256**, and a generally stowed position, in which the gate **256** does not further divide and compartmentalize the cargo area of the upper basket **206**. In like manner, the lower basket **210** includes a similar gate **258** that divides and compartmentalizes the cargo area of the lower basket **210**.

[084] Regarding the toddler seat of the lower basket **210**, a seat covering **260** is attached to the floor of the lower basket **210** in a generally flat orientation against the bottom of the lower basket **206** so as to define a seating area of the toddler seat.

[085] Regarding the upper and lower handles, printed media **262** with promotional advertisements preferably is positioned within the opening areas as schematically illustrated in FIGS. 10-15.

[086] Lastly, a wheel base in the rear of the cart **200** may be longer than a wheel base in the front of the cart. Alternatively, the wheel bases may be approximately the same.

[087] Carts in accordance with embodiments of the invention are believed to have a smaller footprint while providing larger cargo space than conventional carts. Furthermore, it is contemplated that one or more embodiments of carts of the present invention can be used in many different shopping contexts including, for example, grocery stores, warehouse clubs, home improvement retailers, drug chains and specialty retailers. In each context the distance between the baskets vertically and horizontally, the size of each basket, and even slight modifications to the shape of the baskets can be modified, altered, or changes so as to accommodate the size, shape, and other attributes of items intended to be placed into the carts. For example, a home improvement retailer like The Home Depot may require a smaller upper basket with a larger lower basket in order to handle larger items, while some other retailers might prefer the upper and lower baskets be similar in size. Such modifications are within the scope of the invention.

[088] Based on the foregoing description, it will be readily understood by those persons skilled in the art that the present invention is susceptible of broad utility and application. Many embodiments and adaptations of the present invention other than those specifically described herein, as well as many variations, modifications, and equivalent arrangements, will be apparent from or reasonably suggested by the present invention and the foregoing descriptions thereof, without departing from the substance or scope of the present invention. Accordingly, while the present invention has been described herein in detail in relation to one or more preferred embodiments, it is to be understood that this disclosure is only illustrative and exemplary of the present invention and is made merely for the purpose of providing a full and enabling disclosure of the invention. The foregoing disclosure is not intended to be construed to limit the present invention or otherwise exclude any such other embodiments, adaptations, variations, modifications or equivalent arrangements, the present invention being limited only by the claims appended hereto and the equivalents thereof. Thus, for example, while the push bar of the prior art is omitted in the illustrated preferred embodiments, it is contemplated that in some embodiments of the invention a push bar is included. Additionally, while the baskets and rack have been described as preferably being formed from wire, it is contemplated within the scope of the invention that any or all of the baskets and rack be formed from plastic in at least some embodiments of the invention; and that any or all of the baskets and rack be made from formed metal in at least some embodiments of the invention. Moreover, it is further contemplated that the chassis be made from plastic or formed metal in at least some embodiments of the invention.

What is claimed is:

1. A cart, comprising:
  - (a) a chassis;
  - (b) wheels attached to the chassis for rolling of the cart;
  - (c) an upper basket attached to the chassis and defining an upper cargo area for receiving articles for transport on the cart; and
  - (d) a lower basket attached to the chassis and defining a lower cargo area for receiving articles for transport on the cart;
  - (e) wherein the cart includes no widthwise push bar in a rear of the cart for pushing of the cart by a person.
2. The cart of claim 1, wherein the cart is a shopping cart.
3. The cart of claim 1, wherein one or both of the baskets each comprises a compartment divider for forming a plurality of compartments in the cargo area of the basket for separating articles placed in the basket.
4. The cart of claim 1, wherein one or both of the baskets each comprises a wire basket.
5. The cart of claim 1, wherein one or both of the baskets each comprises a wire grid defining a bottom of the basket.
6. The cart of claim 5, wherein both baskets each comprises a wire grid defining a bottom of the basket with the grid of the upper basket defining smaller openings between wires than that defined by the grid of the lower basket.
7. The cart of claim 5, wherein the wire grid bends to extend upwardly at the front of the basket to further define a front wall of the basket.
8. The cart of claim 1, wherein one or both of the baskets each comprises lengthwise wires extending in generally parallel, spaced relation to define a side wall of the basket.
9. The cart of claim 1, wherein the upper basket is cantilevered over the lower basket.
10. The cart of claim 1, wherein the chassis comprises a widthwise support member on which the upper basket is cantilevered over the lower basket.
11. The cart of claim 10, wherein such widthwise support member is the only part of the chassis that extends the width of the cart and that is directly connected to and directly supports the upper basket in its cantilevered position over the lower basket.
12. The cart of claim 1, wherein the cart further comprises a rack located under the lower basket.
13. The cart of claim 12, wherein the rack preferably comprises a wire framework that is bounded at the front and sides by the chassis, including a portion of the chassis that defines a U-shaped bottom bumper of the cart that extends around the front and part of the sides of the bottom of the cart.



14. The cart of claim 12, wherein the lower basket is cantilevered over the rack, and the chassis comprises a widthwise support member on which the lower basket is cantilevered over the rack.
15. The cart of claim 14, wherein such widthwise support member is the only part of the chassis that extends the width of the cart and that is directly connected to and directly supports the lower basket in its cantilevered position over the rack.
16. The cart of claim 1, wherein the wheels include a pair of front wheels and a pair of back wheels.
17. The cart of claim 16, wherein each wheel of the two pair of wheels swivel 360 degrees.
18. The cart of claim 16, wherein each of the pair of front wheels swivel 360 degrees, and neither of the pair of back wheels swivel.
19. The cart of claim 1, wherein the cart is designed and configured to nest with other like carts.
20. The cart of claim 19, wherein the nesting is accomplished by pushing the front of a first one of the carts into the rear of a second one of the carts such that the upper basket of the first cart is received within the upper basket of the second cart, and the lower basket of the first cart is received within the lower basket of the second cart.
21. The cart of claim 20, wherein, when nesting, a rear wall of the upper basket of the second cart preferably collapses in response to the front of the upper basket of the first cart being pushed there against, and a rear wall of the lower basket of the second cart preferably collapses in response to the front of the lower basket of the first cart being pushed there against.
22. The cart of claim 1, wherein the cart comprises one or more cup holders.
23. The cart of claim 22, wherein each cup holder is attached to the chassis at the uppermost part of the cart. of the pair of upper ring handles includes a cup holder attached thereto.
24. The cart of claim 1, wherein the cart comprises a latch located on or attached to a basket on a side of the cart, whereby a purse or other personal item having a strap or ring can be latched to the cart in a secure location and manner.
25. The cart of claim 1, wherein access is unobstructed to the upper basket and to the lower basket from the rear of the cart by a person.
26. The cart of claim 1, wherein the chassis comprises elongate members connected together, such as for example by welding or being integrally connected by molding or other formation technique.
27. The cart of claim 26, wherein the elongate members comprise tubes having oval, rectangular, or triangular cross-sectional profiles, as well as combinations thereof.
28. The cart of claim 26, wherein the chassis consists of said elongate members connected together.
29. The cart of claim 1, wherein the chassis defines areas on opposite lateral sides of the cart for gripping and pushing the cart by a person when standing at the rear of the cart.

30. The cart of claim 29, wherein the areas of the chassis preferably are curved.
31. The cart of claim 29, wherein the chassis defines on each of the opposite lateral sides of the cart a pair of vertically spaced handles.
32. The cart of claim 31, wherein each handle surrounds and defines an interior opening area.
33. The cart of claim 32, wherein each handles comprises a handle bar shaped in an oval.
34. The cart of claim 33, wherein the interior opening area is configured to be used for promotional space.
35. The cart of claim 31, wherein one or more elongate members of the chassis on each side of the cart extend between and connect the handles.
36. The cart of claim 35, wherein the handles and an elongate member connecting the handles on a lateral side of the cart define the shape of armless spectacles.
37. The cart of claim 35, wherein said elongate member is curved and in the shape of an arc in its extent between the handles, with said elongate member extending beyond the rear of the upper basket and the rear of the lower basket so as to define the rearmost part of the cart.
38. The cart of claim 31, wherein the handles on each side are vertically located over a wheel.
39. The cart of claim 1, wherein the rear area of the upper basket preferably defines a seat for an infant.
40. The cart of claim 1, wherein the lower basket defines a seat at a rear area thereof for a toddler.
41. The cart of claim 40, wherein a rear wall of the lower basket moves away so that the rear area including rear edge of the lower basket can be used as a ledge for sitting of the toddler.
42. The cart of claim 40, wherein the rear of the upper basket is horizontally offset toward the front of the cart relative to the rear of the lower basket so as to provide clearance by which a toddler can sit up when seated on the rear ledge of the lower basket.
43. A cart, comprising:
  - (a) a chassis;
  - (b) wheels attached to the chassis for rolling of the cart;
  - (c) an upper basket attached to the chassis and defining an upper cargo area for receiving articles for transport on the cart; and
  - (d) a lower basket attached to the chassis and defining a lower cargo area for receiving articles for transport on the cart;
  - (e) wherein the upper basket is cantilevered over the lower basket.
44. The cart of claim 43, wherein the chassis comprises a widthwise support member on which the upper basket is cantilevered over the lower basket.
45. The cart of claim 44, wherein such widthwise support member is the only part of the chassis that extends the width of the cart and that is directly connected to and directly supports the upper basket in its cantilevered position over the lower basket.
46. The cart of claim 43, wherein the cart further comprises a rack located under the lower basket.

47. The cart of claim 46, wherein the rack preferably comprises a wire framework that is bounded at the front and sides by the chassis, including a portion of the chassis that defines a U-shaped bottom bumper of the cart that extends around the front and part of the sides of the bottom of the cart.
48. The cart of claim 46, wherein the lower basket is cantilevered over the rack, and the chassis comprises a widthwise support member on which the lower basket is cantilevered over the rack.
49. The cart of claim 48, wherein such widthwise support member is the only part of the chassis that extends the width of the cart and that is directly connected to and directly supports the lower basket in its cantilevered position over the rack.
50. A cart, comprising:
  - (a) a chassis;
  - (b) wheels attached to the chassis for rolling of the cart;
  - (c) an upper basket attached to the chassis and defining an upper cargo area for receiving articles for transport on the cart; and
  - (d) a lower basket attached to the chassis and defining a lower cargo area for receiving articles for transport on the cart;
  - (e) wherein the chassis defines areas on opposite lateral sides of the cart for gripping and pushing the cart by a person when standing at the rear of the cart.
51. The cart of claim 50, wherein the chassis comprises elongate members connected together.
52. The cart of claim 51, wherein the chassis consists of said elongate members connected together.
53. The cart of claim 52, wherein the areas of the chassis preferably are curved.
54. The cart of claim 53, wherein the chassis defines on each of the opposite lateral sides of the cart a pair of vertically spaced handles.
55. The cart of claim 54, wherein each handle surrounds and defines an interior opening area.
56. The cart of claim 55, wherein each handle comprises a handle bar shaped in an oval.
57. The cart of claim 56, wherein the interior opening area is configured to be used for promotional space.
58. The cart of claim 54, wherein one or more elongate members of the chassis on each side of the cart extend between and connect the handles.
59. The cart of claim 58, wherein the handles and an elongate member connecting the handles on a lateral side of the cart define the shape of armless spectacles.
60. The cart of claim 58, wherein a said elongate member is curved and in the shape of an arc in its extent between the handles.
61. The cart of claim 60, wherein said curved elongate member extends beyond the rear of the upper basket and the rear of the lower basket so as to define the rearmost part of the cart.

62. The cart of claim 54, wherein the handles on each side are vertically located over a wheel.
63. A cart, comprising:
  - (a) a chassis;
  - (b) wheels attached to the chassis for rolling of the cart;
  - (c) an upper basket attached to the chassis and defining an upper cargo area for receiving articles for transport on the cart; and
  - (d) a lower basket attached to the chassis and defining a lower cargo area for receiving articles for transport on the cart;
  - (e) wherein the rear area of the upper basket preferably defines a seat for an infant; and
  - (f) wherein the lower basket defines a seat at a rear area thereof for a toddler.
64. The cart of claim 63, wherein a rear wall of the lower basket moves away so that the rear area including rear edge of the lower basket can be used as a ledge for sitting of the toddler.
65. The cart of claim 64, wherein the rear of the upper basket is horizontally offset toward the front of the cart relative to the rear of the lower basket so as to provide clearance by which a toddler can sit up when seated on the rear ledge of the lower basket.
66. A cart as shown and described herein.
67. A method of making a cart in accordance with any of the foregoing claims.
68. A method of using a cart in accordance with any of the foregoing claims.
69. A method of making a cart in accordance with any of the foregoing claims.

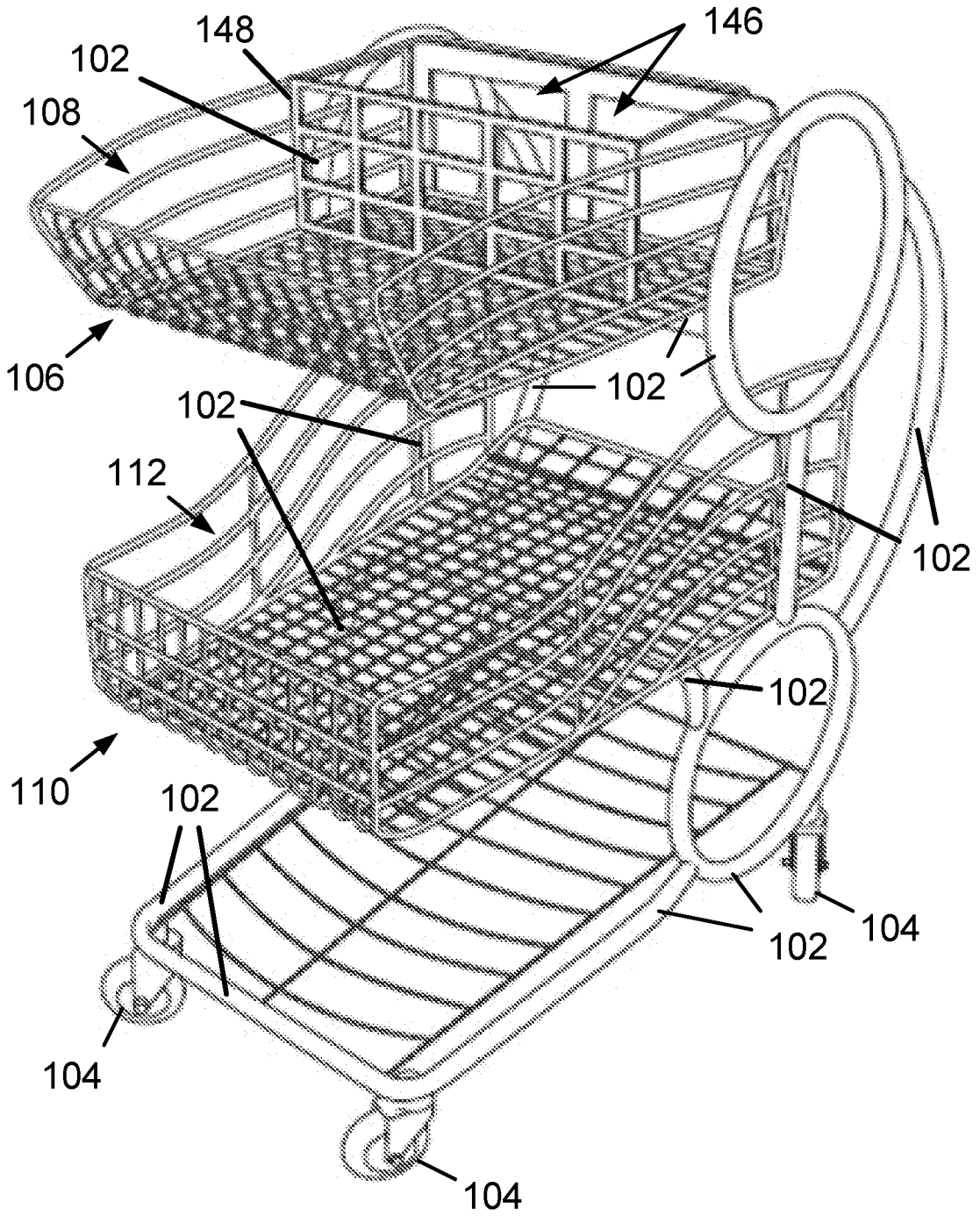

100

FIG. 1

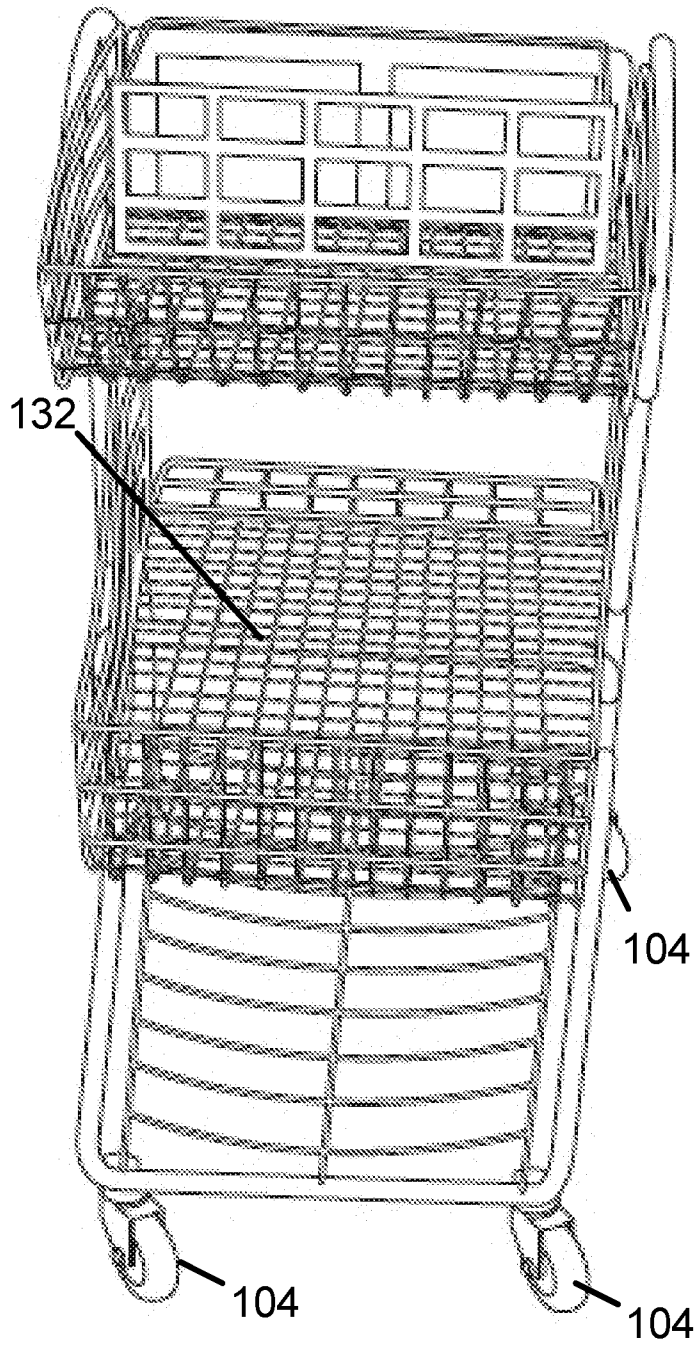

100

FIG. 2

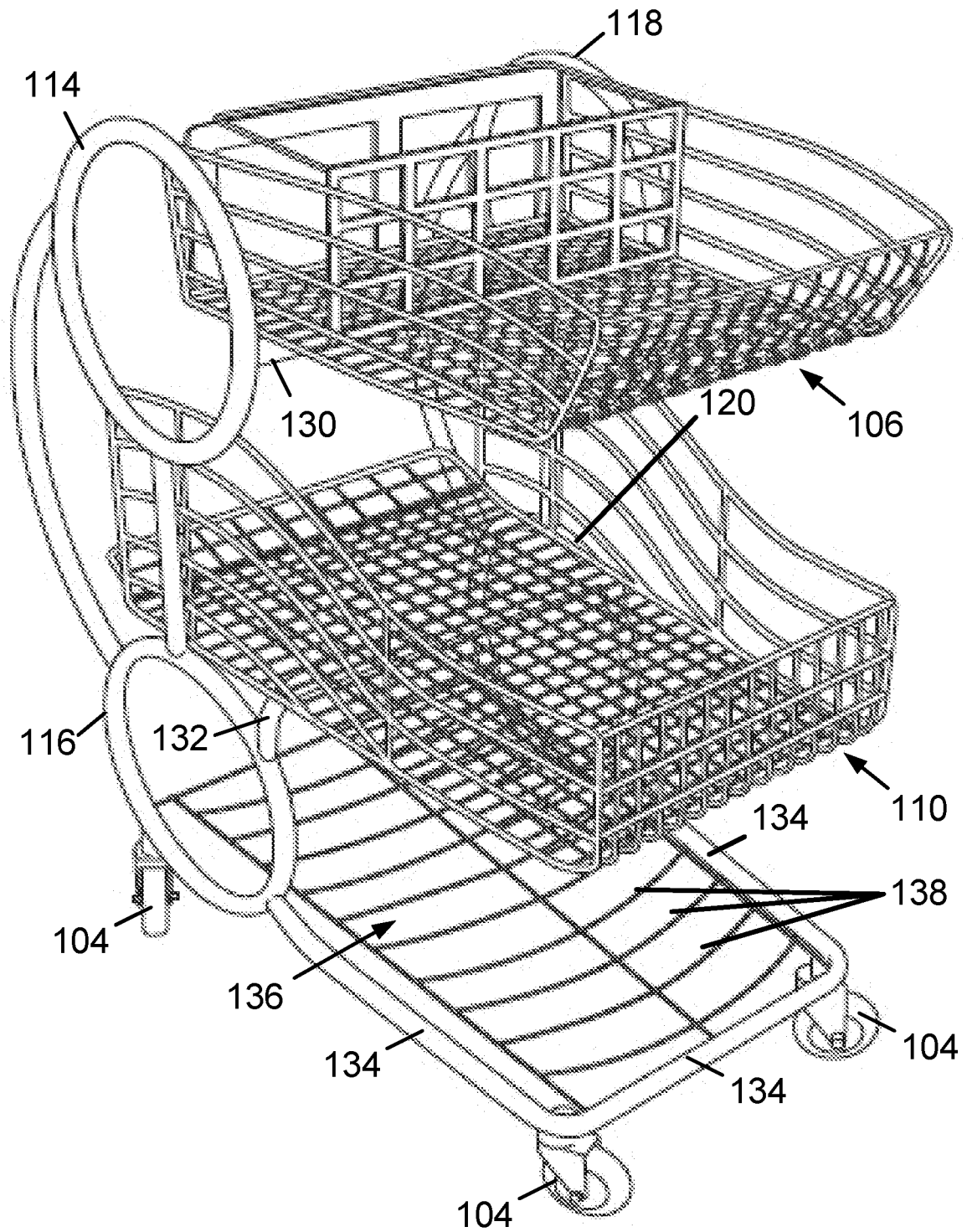

100

FIG. 3

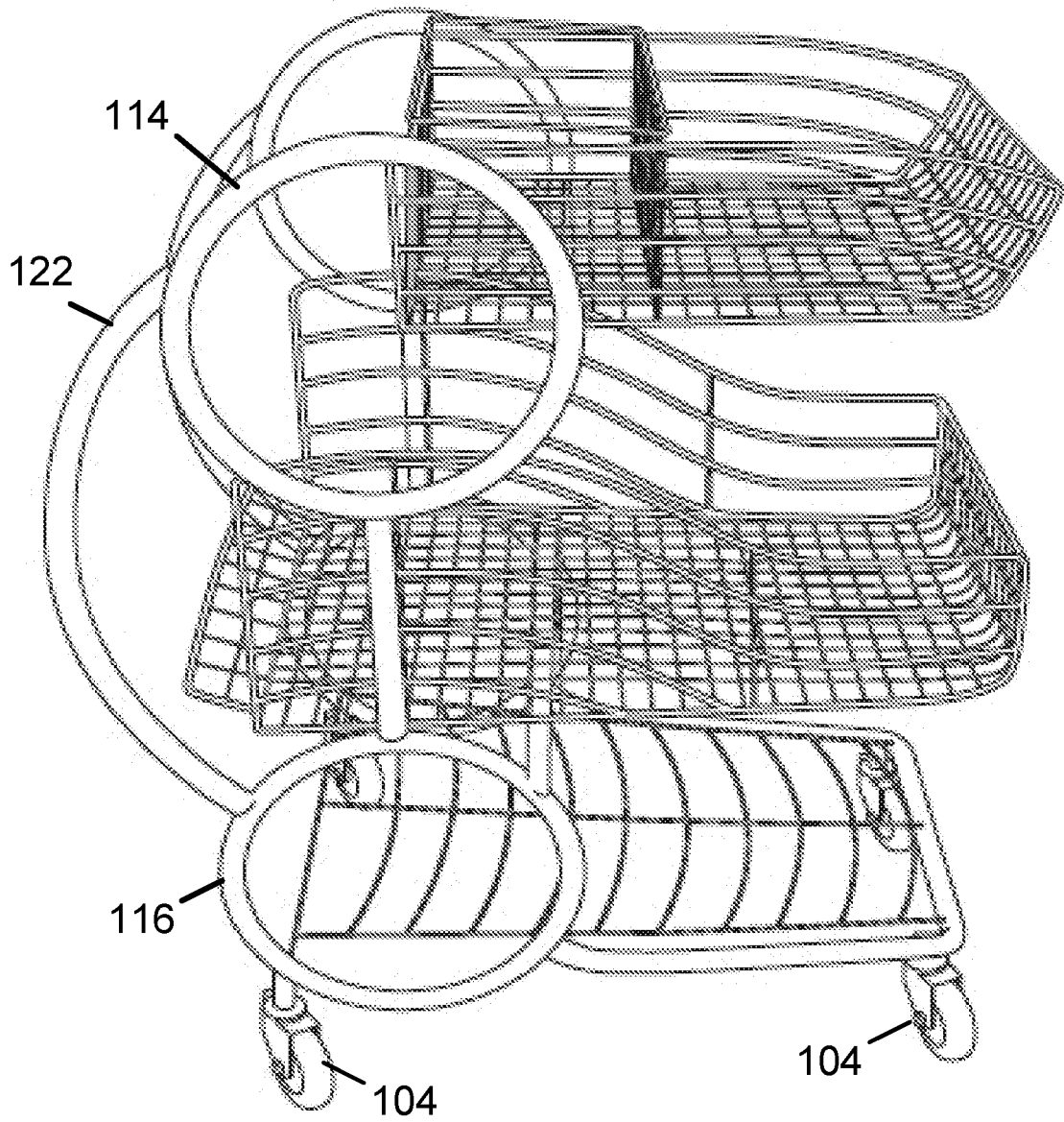

100

FIG. 4



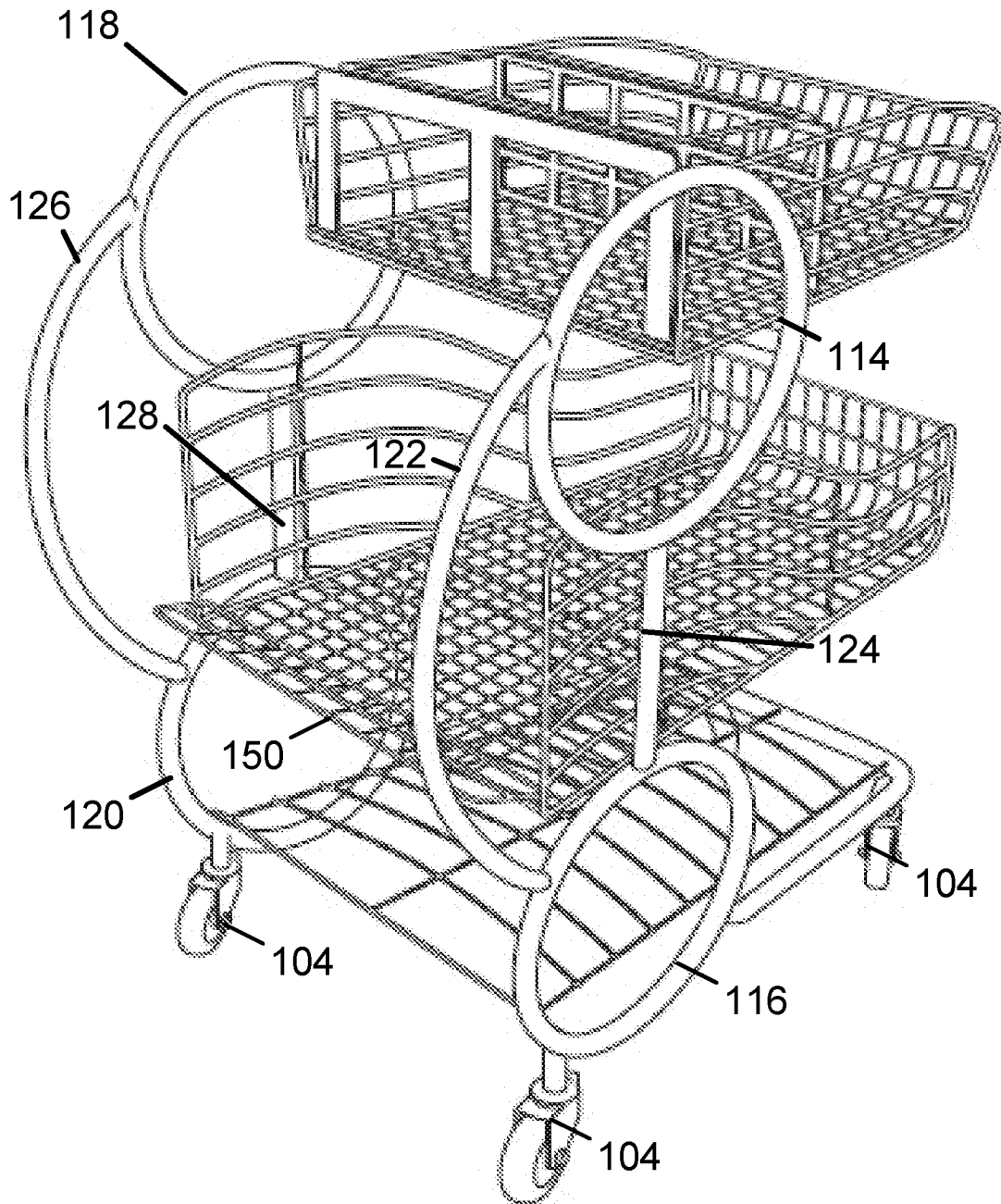

100

FIG. 5

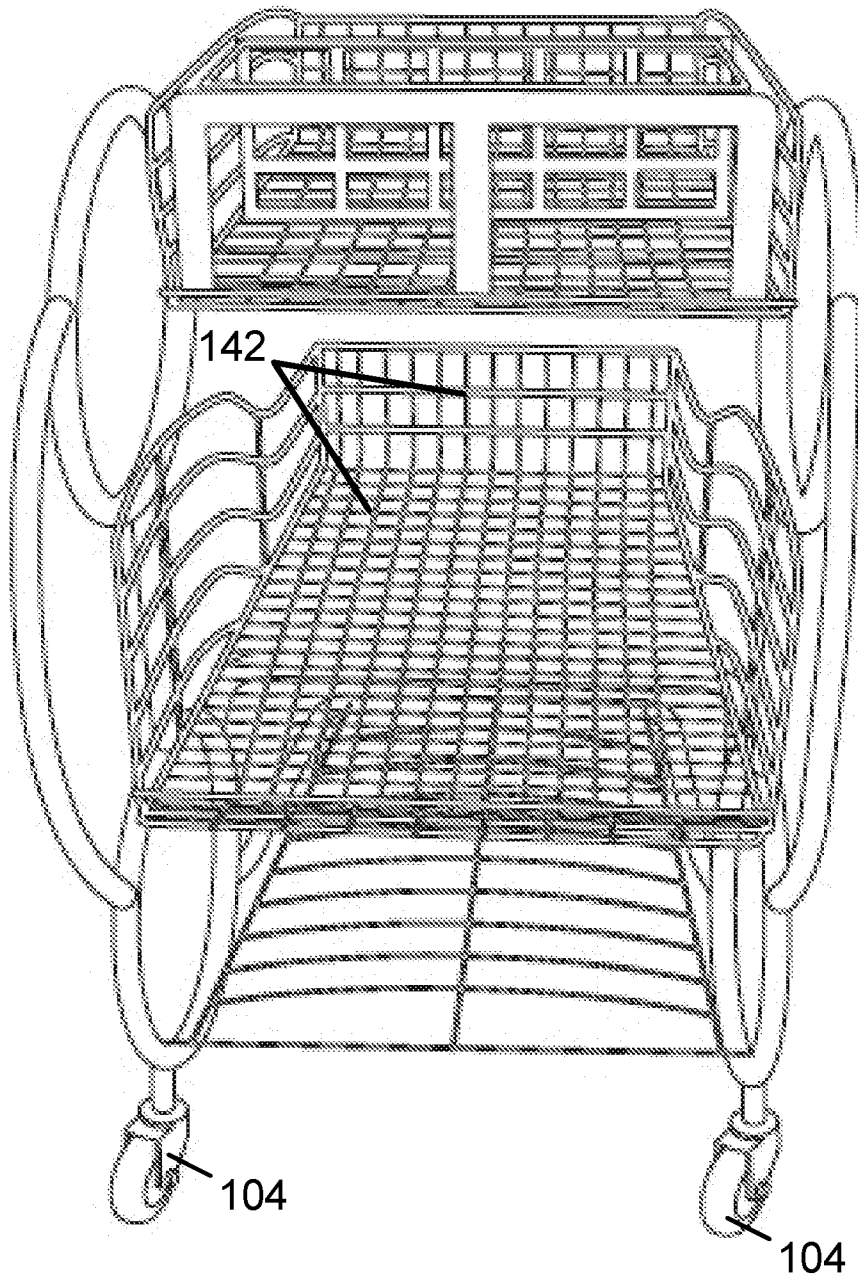

100

FIG. 6

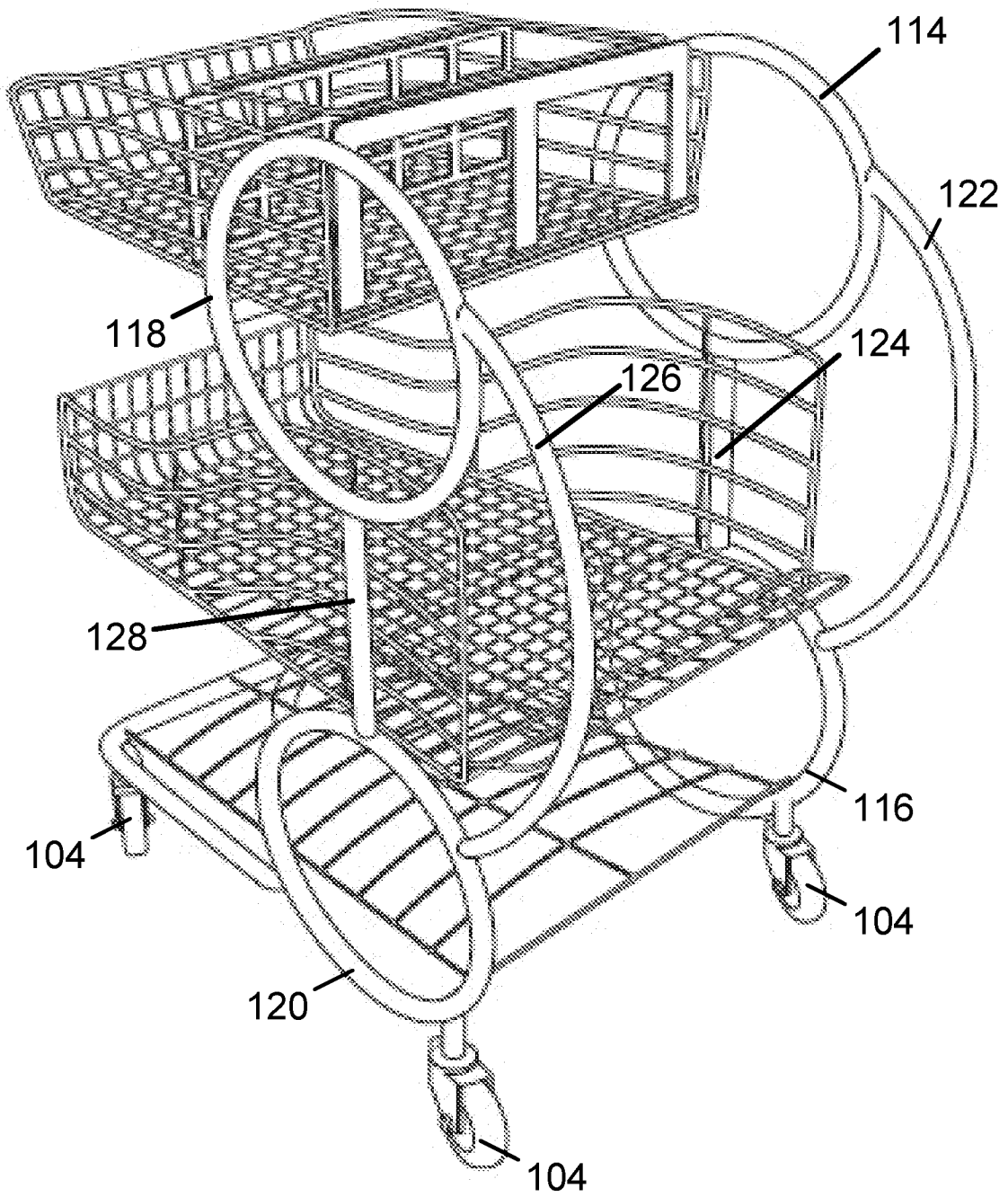

100

FIG. 7

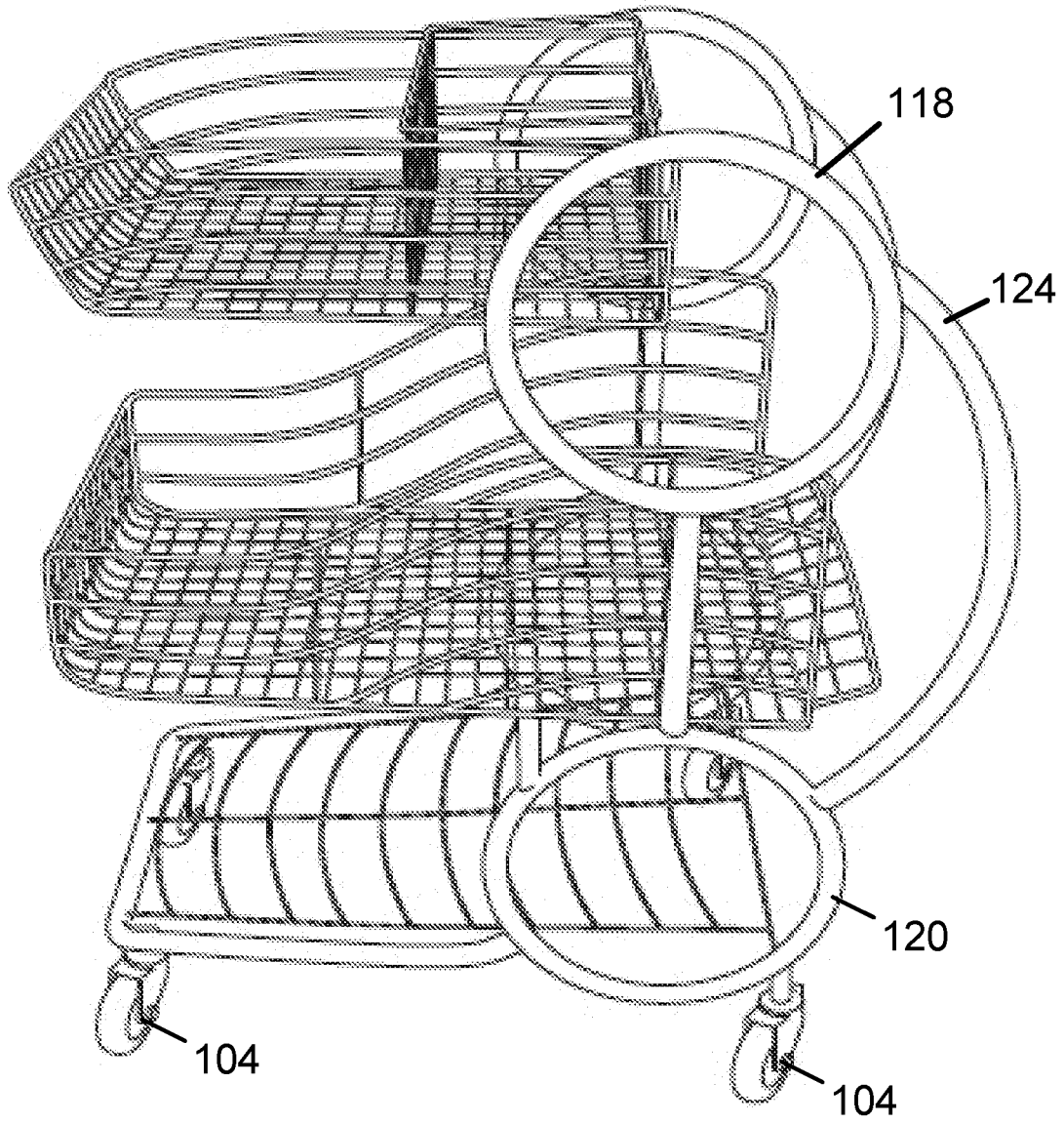

100

FIG. 8

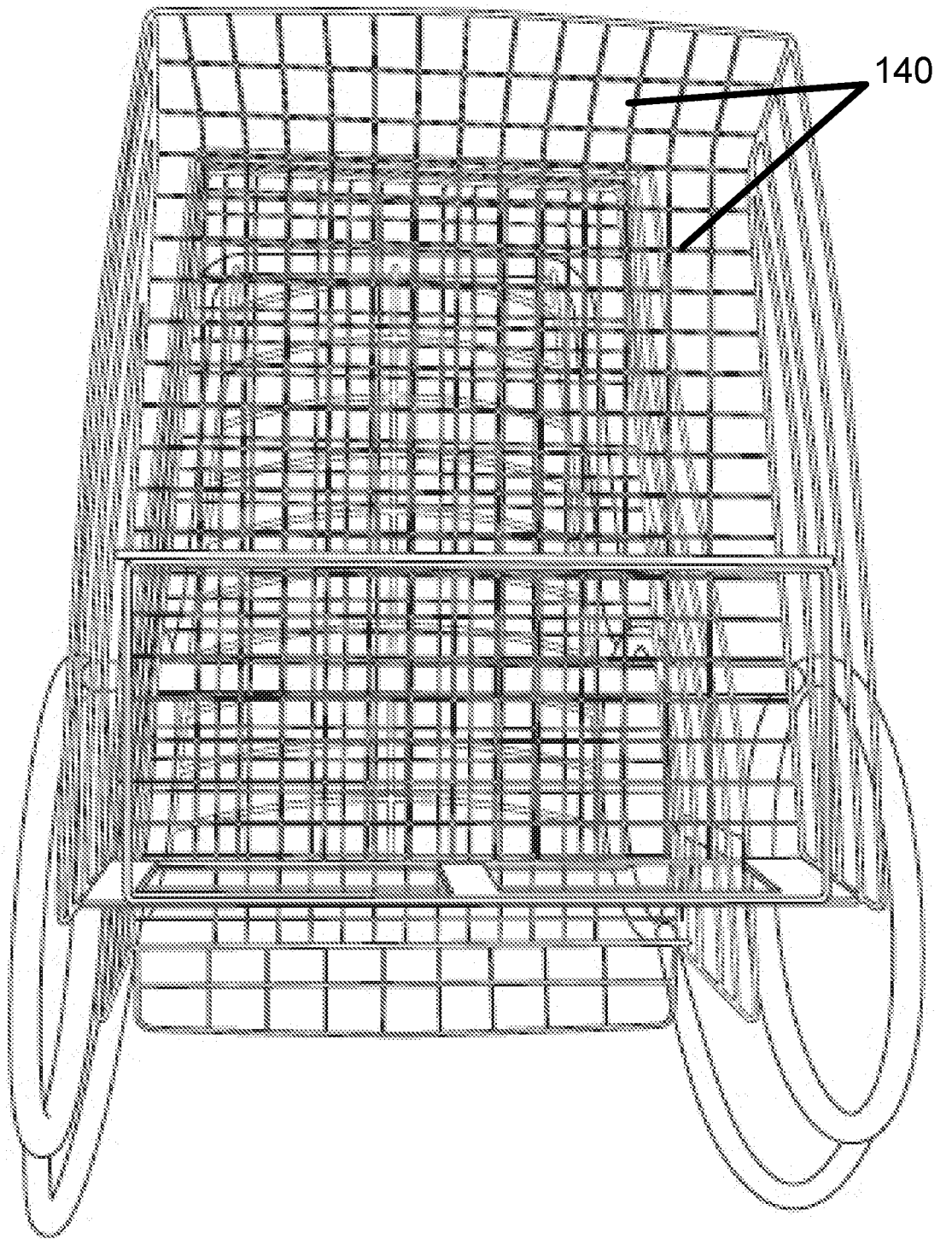

100

FIG. 9

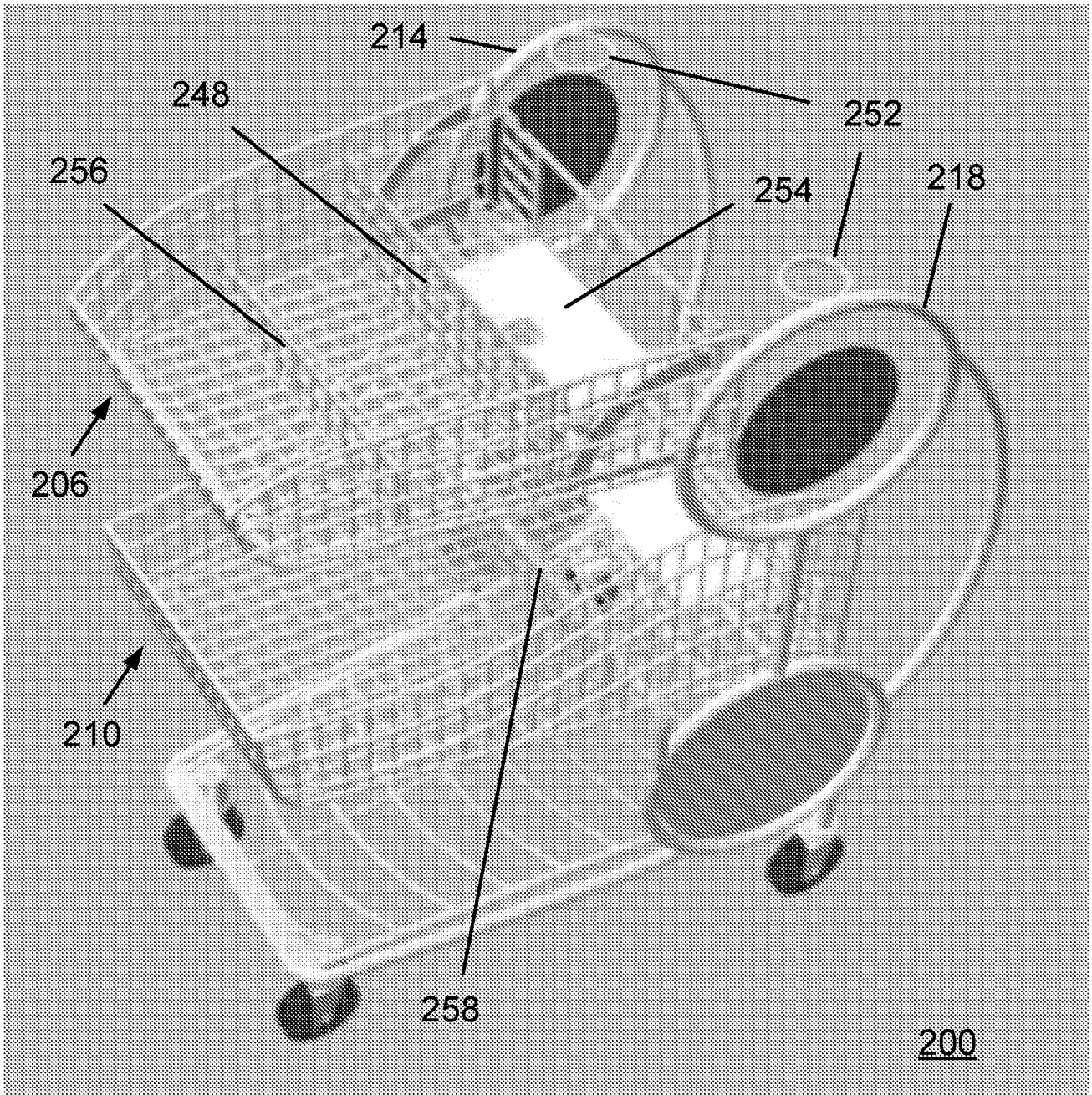

FIG. 10



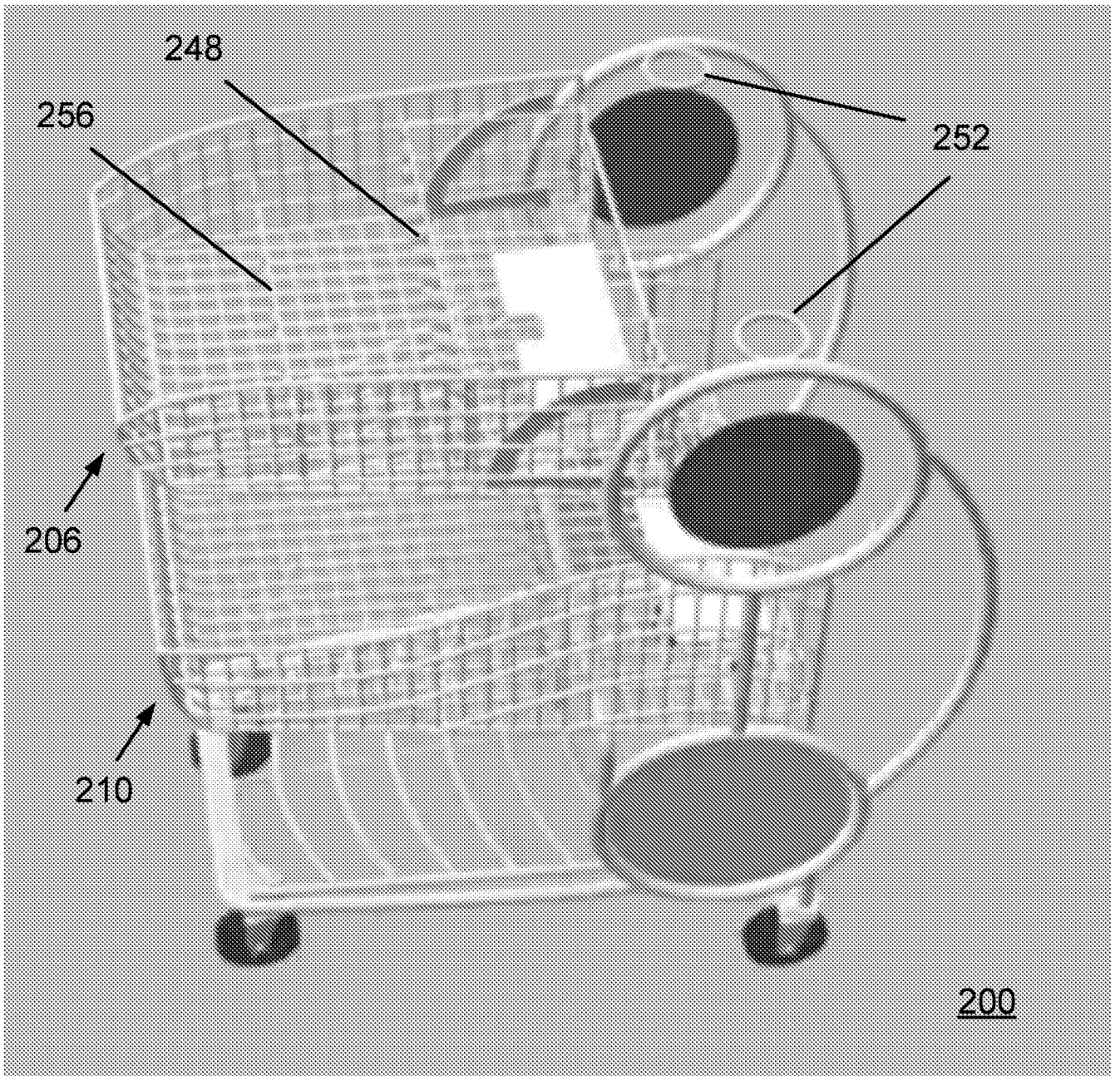

FIG. 11

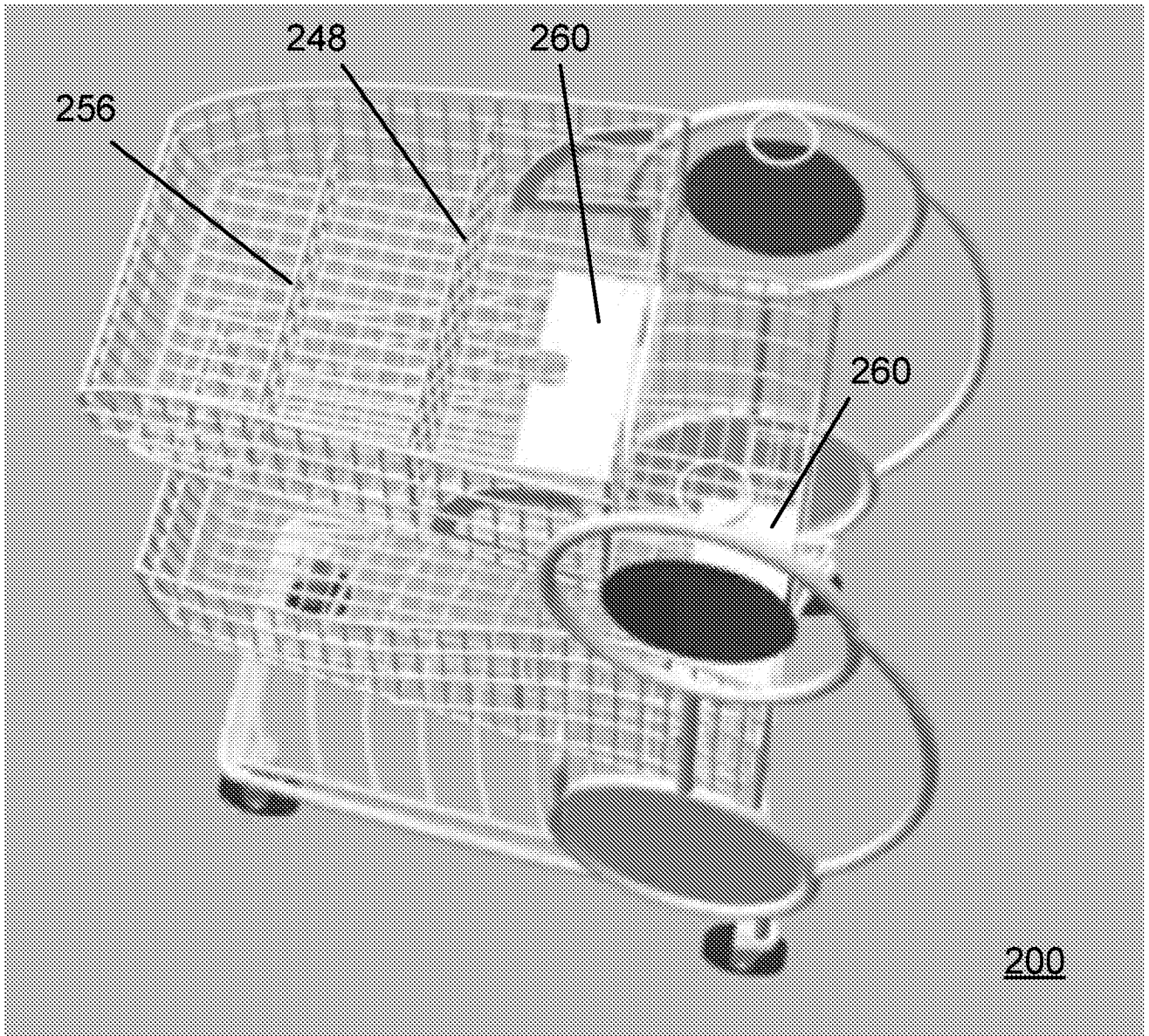

FIG. 12



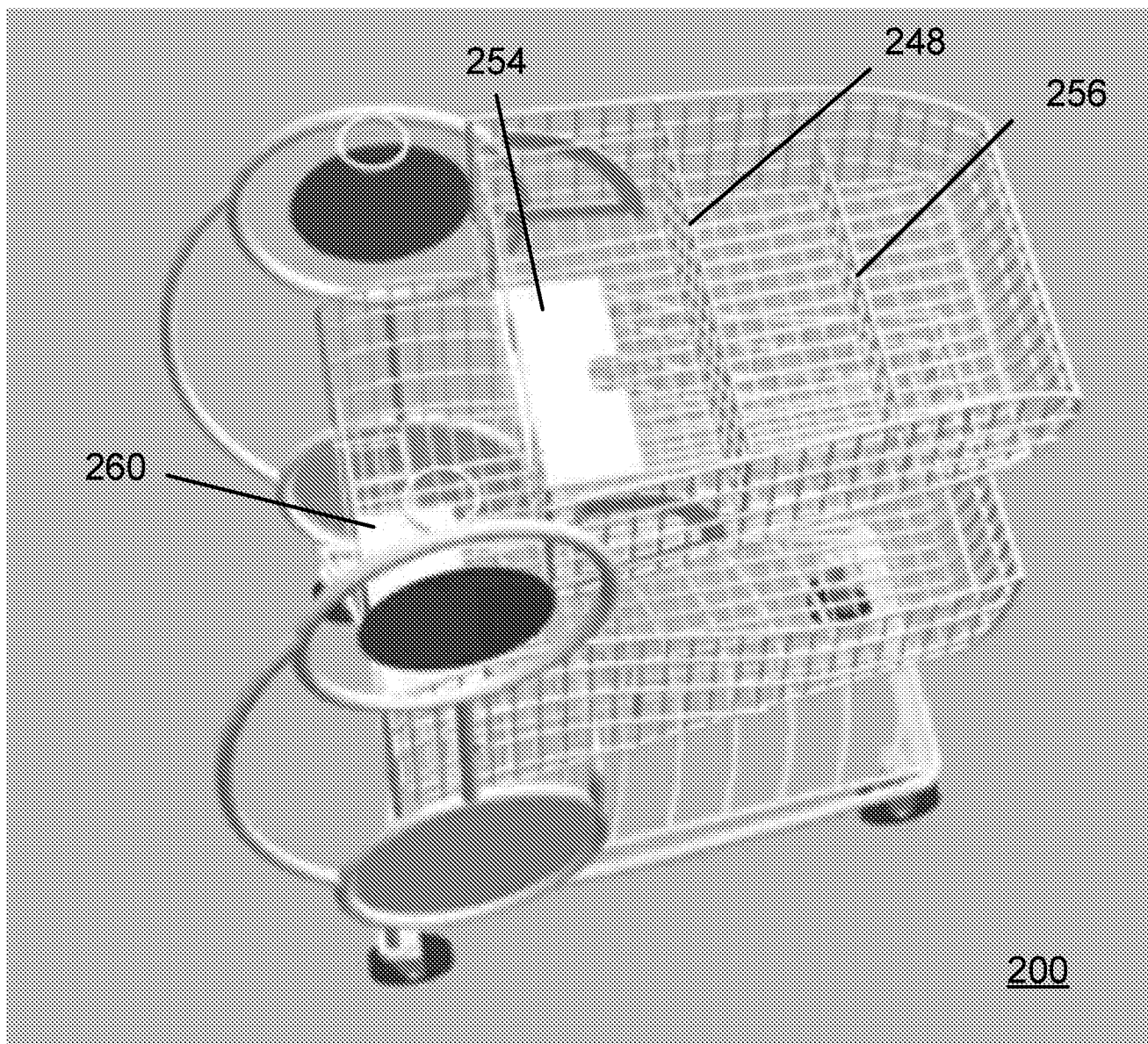

FIG. 13

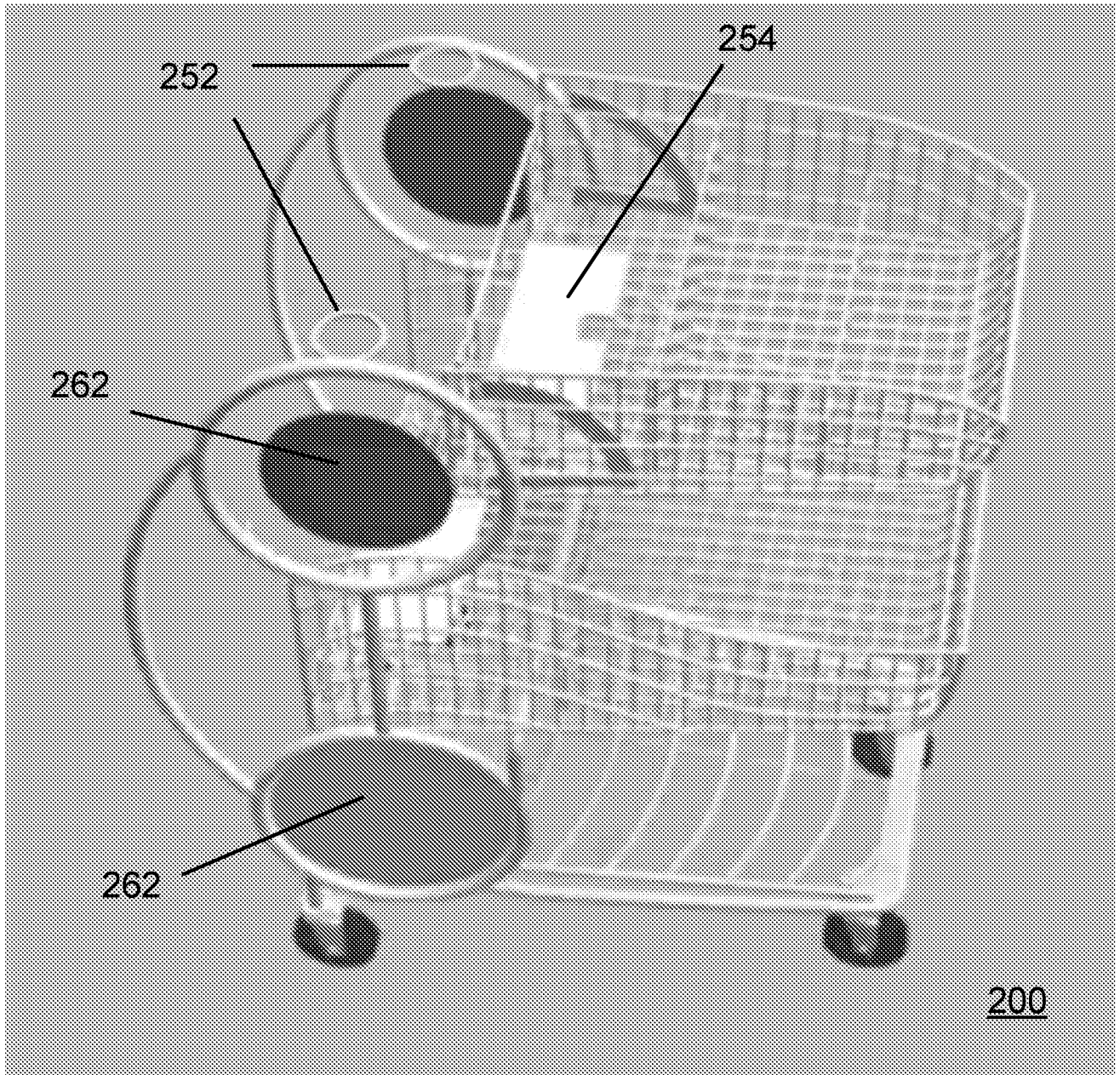

FIG. 14

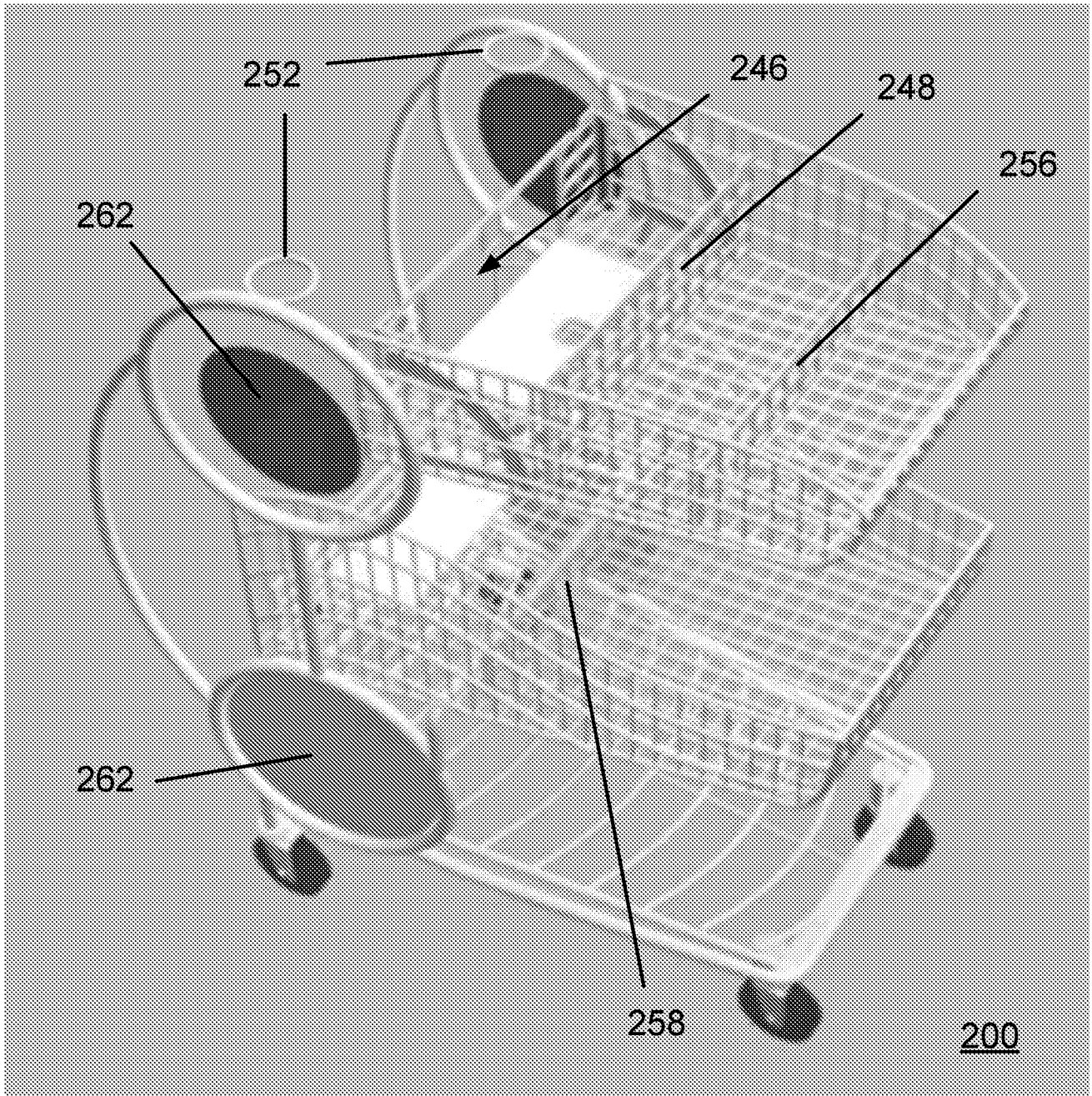

FIG. 15

## INTERNATIONAL SEARCH REPORT

International application No.

PCT/US 16/19206

## A. CLASSIFICATION OF SUBJECT MATTER

IPC(8) - B62B 3/14 (2016.01)

CPC - B62B 3/14

According to International Patent Classification (IPC) or to both national classification and IPC

## B. FIELDS SEARCHED

Minimum documentation searched (classification system followed by classification symbols)

IPC (8): B62B 3/14 (2016.01)

CPC: B62B 3/14

Documentation searched other than minimum documentation to the extent that such documents are included in the fields searched  
 IPC (8): B62B 3/18 (2016.01). CPC: B62B 3/18, B62B 3/1468. USPC: D34/27, 280/33\*, 280/47\*, 220/8, 217/122, 211/126\*, 206/519, 280/3, 211/1, 280/79.3.

Electronic data base consulted during the international search (name of data base and, where practicable, search terms used)  
 PatBase. Google (Web, Scholar, Patent). Search Terms: Back, Bar, Basket\*, Bend, Bugg\*, Cart\*, Chair, Children, Curve, Curved, Dolly, Double, Dual, Elliptical, Eyeglass, Front, Gate, Grasp, Grip, Grocery, Handle, Handlebar, Hover, Infant, Lower, Lumber, Open, Orientation, Oval, Pistol Grip, Plywood, Push, Robotic, Seat, Second, Shop\*, Shopping, Si

## C. DOCUMENTS CONSIDERED TO BE RELEVANT

Category*	Citation of document, with indication, where appropriate, of the relevant passages	Relevant to claim No.
X	US 5,427,394 A (LAUTO) 27 June 1995 (27.06.1995) Figs. 1-2; col 3 ln 9-17, 26-36, 43-47, 62-68, col 5 ln 28-34.	1-2, 12, 16-18, 26, 28-29
----- Y		3-8, 10-11, 22-25, 27, 30, 40
----- A		9, 13-15, 19-21, 31-39, 41-42
Y	US 7,766,347 B2 (RYAN et al.) 03 August 2010 (03.08.2010) Figs. 1-2, 8; col 3 ln 15-24, 27-34.	3
Y	US 7,396,025 B2 (ONDRASIK) 08 July 2008 (08.07.2008) Figs. 1-4; col 3 ln 51-61, 64-66, col 6 ln 7-8.	4-8, 40
----- A		41-42
Y	US 7,681,891 B2 (DEAL et al.) 23 March 2010 (23.03.2010) Figs. 1-4; col 2 ln 38-39, 41-43, 64 - col 3 ln 1.	10-11
Y	US 2,479,530 A (WATSON) 16 August 1949 (16.08.1949) Figs. 1-3; col 1 ln 42-44, 55 - col 2 ln 3, 20-32.	25, 30
Y	US 7,566,069 B1 (ORTEGA et al.) 28 July 2009 (28.07.2009) Figs. 1-2; col 3 ln 19-23, 31-34, 44-48.	22-23, 27
Y	US 5,915,631 A (LAXTON et al.) 29 June 1999 (29.06.1999) Figs. 1-2; col 2 ln 10-12, 65 - col 3 ln 1)	24
A	US 5,848,797 A (PAEZ) 15 December 1998 (15.12.1998) Figs. 1-2; col 2 ln 49-61	1-42

 Further documents are listed in the continuation of Box C.

* Special categories of cited documents:	"T" later document published after the international filing date or priority date and not in conflict with the application but cited to understand the principle or theory underlying the invention
"A" document defining the general state of the art which is not considered to be of particular relevance	"X" document of particular relevance; the claimed invention cannot be considered novel or cannot be considered to involve an inventive step when the document is taken alone
"E" earlier application or patent but published on or after the international filing date	"Y" document of particular relevance; the claimed invention cannot be considered to involve an inventive step when the document is combined with one or more other such documents, such combination being obvious to a person skilled in the art
"L" document which may throw doubts on priority claim(s) or which is cited to establish the publication date of another citation or other special reason (as specified)	"&" document member of the same patent family
"O" document referring to an oral disclosure, use, exhibition or other means	
"P" document published prior to the international filing date but later than the priority date claimed	

Date of the actual completion of the international search

13 July 2016 (13.07.2016)

Date of mailing of the international search report

08 AUG 2016

Name and mailing address of the ISA/US

Mail Stop PCT, Attn: ISA/US, Commissioner for Patents  
 P.O. Box 1450, Alexandria, Virginia 22313-1450  
 Facsimile No. 571-273-8300

Authorized officer:

Lee W. Young

PCT Helpdesk: 571-272-4300  
 PCT OSP: 571-272-7774

## INTERNATIONAL SEARCH REPORT

International application No.

PCT/US 16/19206

**Box No. II Observations where certain claims were found unsearchable (Continuation of item 2 of first sheet)**

This international search report has not been established in respect of certain claims under Article 17(2)(a) for the following reasons:

1.  Claims Nos.:  
because they relate to subject matter not required to be searched by this Authority, namely:
  
2.  Claims Nos.: 66-69  
because they relate to parts of the international application that do not comply with the prescribed requirements to such an extent that no meaningful international search can be carried out, specifically:  
Claims 66-69 are omnibus type claims, not drafted in accordance with Rule 6.2(a), and/or the second and third sentences of Rule 6.4(a).
  
3.  Claims Nos.:  
because they are dependent claims and are not drafted in accordance with the second and third sentences of Rule 6.4(a).

**Box No. III Observations where unity of invention is lacking (Continuation of item 3 of first sheet)**

This International Searching Authority found multiple inventions in this international application, as follows:  
This application contains the following inventions or groups of inventions which are not so linked as to form a single general inventive concept under PCT Rule 13.1. In order for all inventions to be examined, the appropriate additional examination fees must be paid.

Group I, Claims 1-42 directed to a cart comprising no widthwise push bar in a rear of the cart for pushing of the cart by a person.

Group II, Claims 43-49 directed to a cart wherein an upper basket is cantilevered over a lower basket.

Group III, Claims 50-62 directed to a cart wherein a chassis defines areas on opposite lateral sides of the cart for gripping and pushing the cart by a person.

Group IV, Claims 63-65 directed to a cart including seats for infants and toddlers.

\*- See Supplemental Sheet \*-

1.  As all required additional search fees were timely paid by the applicant, this international search report covers all searchable claims.
2.  As all searchable claims could be searched without effort justifying additional fees, this Authority did not invite payment of additional fees.
3.  As only some of the required additional search fees were timely paid by the applicant, this international search report covers only those claims for which fees were paid, specifically claims Nos.:
  
4.  No required additional search fees were timely paid by the applicant. Consequently, this international search report is restricted to the invention first mentioned in the claims; it is covered by claims Nos.:  
1-42

**Remark on Protest**

- The additional search fees were accompanied by the applicant's protest and, where applicable, the payment of a protest fee.
- The additional search fees were accompanied by the applicant's protest but the applicable protest fee was not paid within the time limit specified in the invitation.
- No protest accompanied the payment of additional search fees.

Continuation of Box III, Observations where unity of invention is lacking:

The inventions listed as Groups I-IV do not relate to a single general inventive concept under PCT Rule 13.1 because, under PCT Rule 13.2, they lack the same or corresponding special technical feature(s) for the following reasons:

Group I requires the special technical feature of no widthwise push bar in a rear of the cart for pushing of the cart by a person, not required by Groups II-IV.

Group II requires the special technical feature of an upper basket cantilevered over a lower basket, not required by Groups I and III-IV.

Group III requires the special technical feature of a chassis defining areas on opposite lateral sides of the cart for gripping and pushing the cart by a person, not required by Groups I-II and IV.

Group IV requires the special technical features of a seat for an infant and a seat for a toddler.

The only shared technical feature(s) that would otherwise unify Groups I-IV are a cart comprising a chassis, wheels attached to the chassis for rolling the cart, an upper basket attached to the chassis and defining an upper cargo area for receiving articles for transport in the cart, and a lower basket attached to the chassis and defining a lower cargo area for receiving articles for transport in the cart. However, these technical features do not represent a contribution to the prior art, because they are anticipated by US 5,427,394 A (LAUTO).

Lauto discloses a cart (shopping cart 10, Fig. 1; col 3 ln 9-11), comprising:

a chassis (tubular shaft members 18 and 20, lower storage compartment 12, and handle sections 65, Fig. 1; col 3 ln 20-23, 32-36, col 5 ln 28-34)

wheels (casters 22a-d, Fig. 2; col 3 ln 43-47) attached to the chassis for the rolling of the cart (as illustrated in Fig. 2),

an upper basket (upper storage compartment 16, Fig. 1; col 3 ln 11-15) attached to the chassis (as illustrated in Fig. 2) and defining an upper cargo area (unnumbered; volume contained within 16 as illustrated in Fig. 1; col 3 ln 11-15) for receiving articles for transport in the cart (as illustrated in Fig. 1),

a lower basket (central storage compartment 14, Fig. 1; col 3 ln 11-15) attached to the chassis (as illustrated in Fig. 2) and defining a lower cargo area (unnumbered; volume contained within 14 as illustrated in Fig. 1; col 3 ln 11-15) for receiving articles for transport in the cart (as illustrated in Fig. 1).

As the common technical feature(s) of Groups I-IV were known in the art at the time of the invention, they cannot be considered to be common technical feature(s) that would otherwise unify Groups I-IV.

Therefore, Groups I-IV lack unity under PCT Rule 13.

Notes:

1. While any solid cart occupying space inherently has opposite lateral sides, a chassis is not inherently exposed for contact by a person pushing a cart.

2. Claims 66-69 are omnibus type claims, not drafted in accordance with Rule 6.2(a), and/or the second and third sentences of Rule 6.4(a).