



US 20110144673A1

(19) **United States**

(12) **Patent Application Publication**  
**Zhang et al.**

(10) **Pub. No.: US 2011/0144673 A1**

(43) **Pub. Date: Jun. 16, 2011**

(54) **MATERIAL REMOVAL DEVICE HAVING IMPROVED MATERIAL CAPTURE EFFICIENCY AND METHODS OF USE**

(22) Filed: **Dec. 9, 2010**

**Related U.S. Application Data**

(60) Provisional application No. 61/285,768, filed on Dec. 11, 2009.

**Publication Classification**

(51) **Int. Cl.**  
**A61B 17/22** (2006.01)

(52) **U.S. Cl.** ..... **606/159**

(57) **ABSTRACT**

The present invention provides an improved atherectomy catheter having means for directing particles generated by a cutting element into a collection chamber. Methods of directing the cut material from a blood vessel lumen into a collection chamber are also provided.

(75) Inventors: **Zhiyong Zhang**, Edina, MN (US);  
**John Robert Moberg**, Elk River, MN (US);  
**Hussain S. Rangwala**, Orange, CA (US);  
**Thomas John McPeak**, Shakopee, MN (US);  
**William Joseph Whealon**, Chaska, MN (US);  
**Richard S. Kusleika**, Eden Prairie, MN (US)

(73) Assignee: **FOX HOLLOW TECHNOLOGIES, INC.**,  
Plymouth, MN (US)

(21) Appl. No.: **12/964,544**

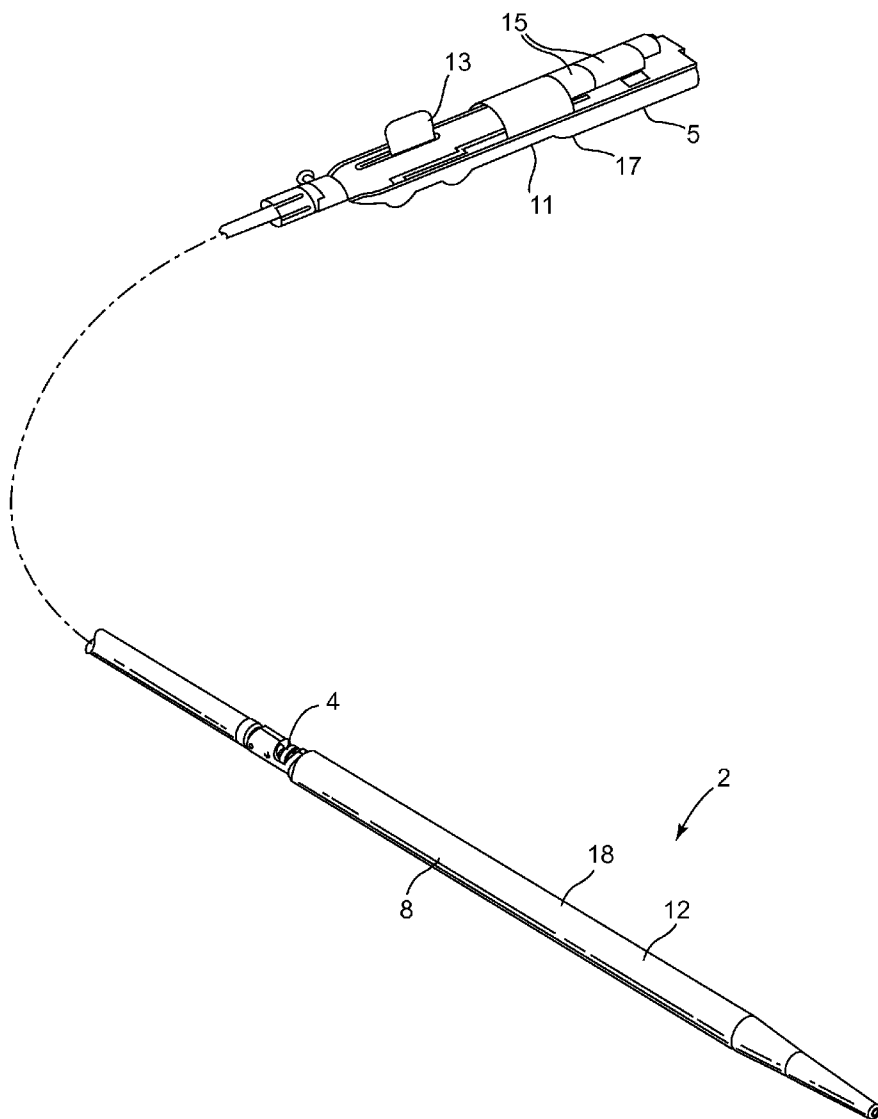

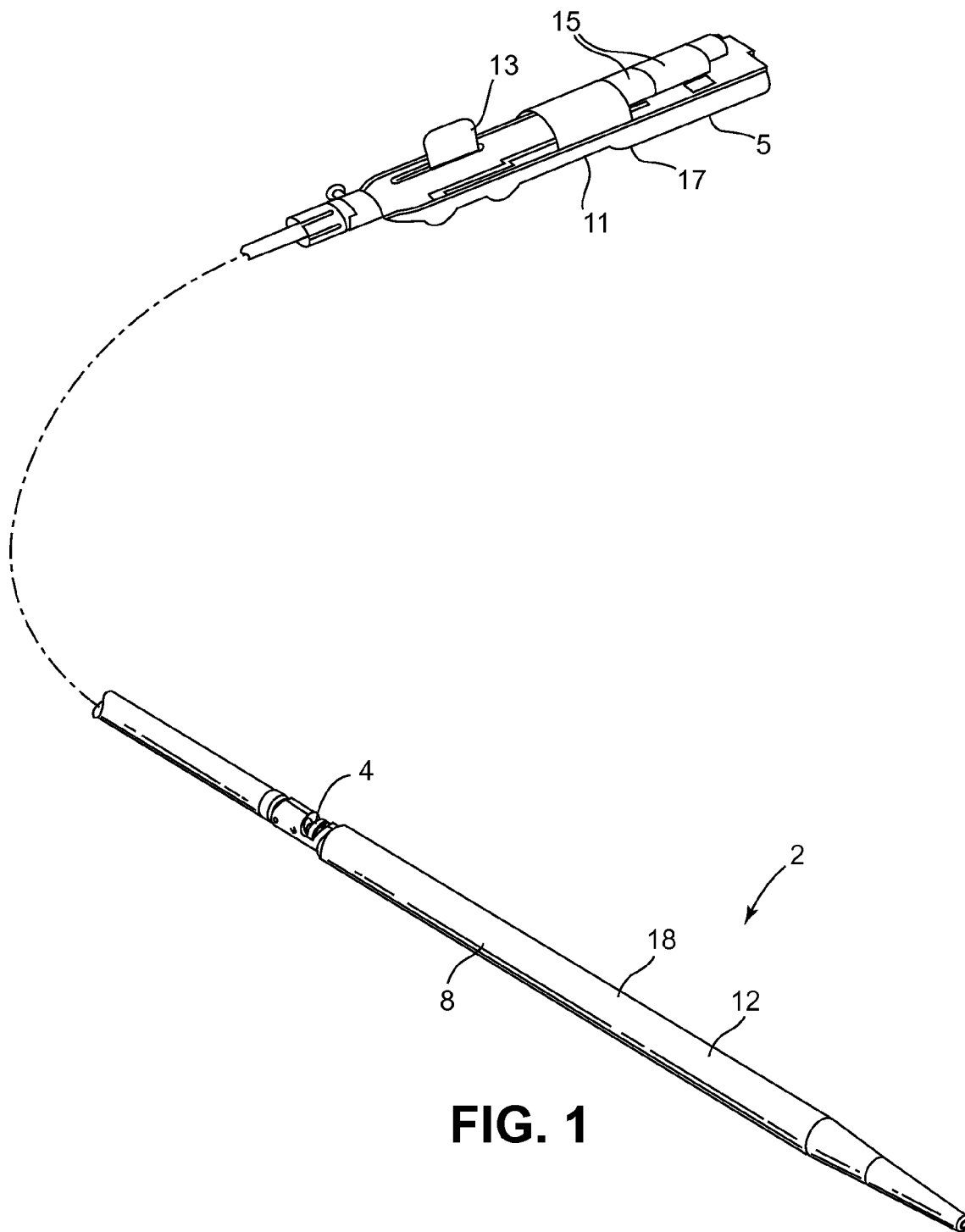

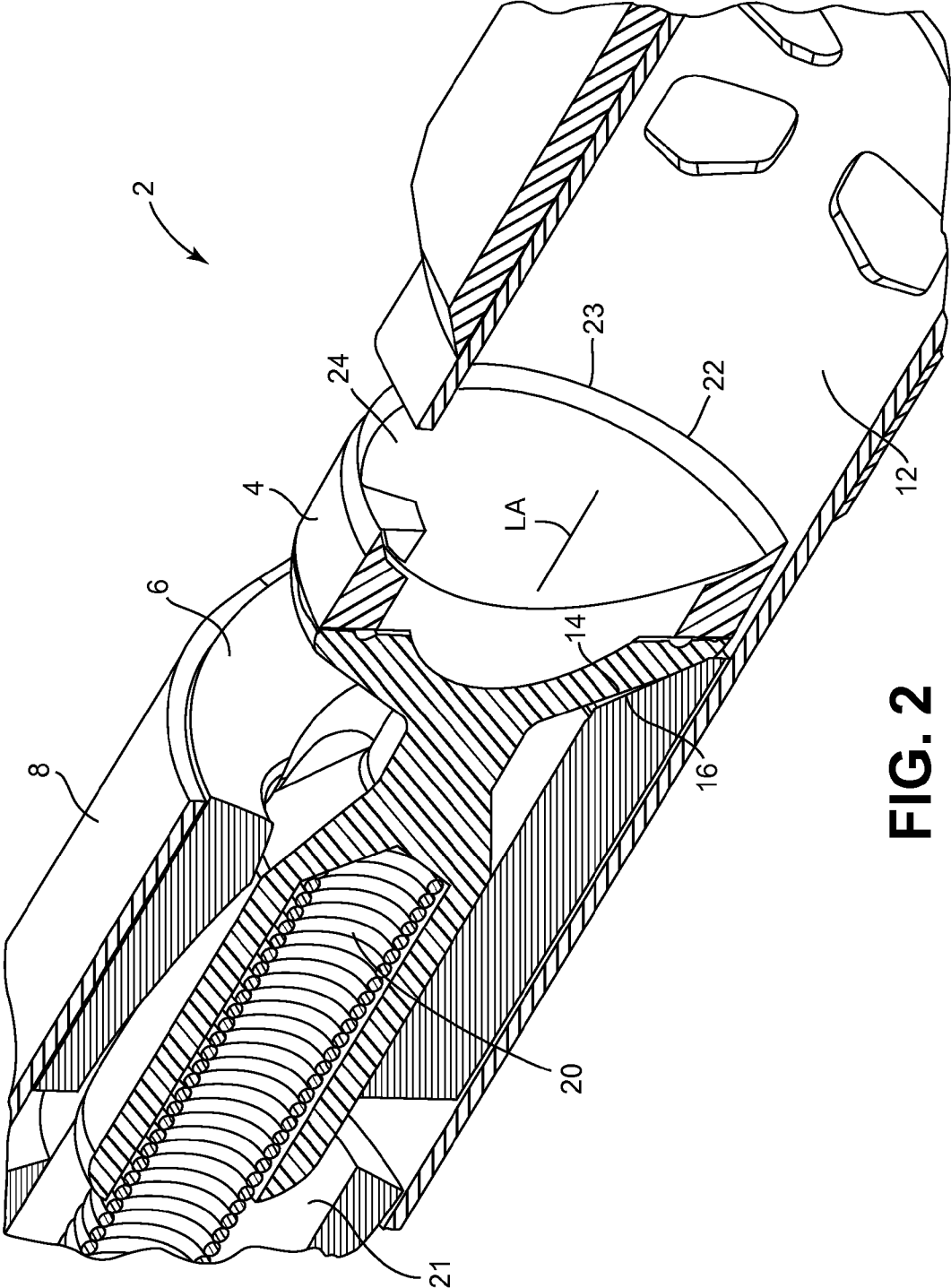

FIG. 2

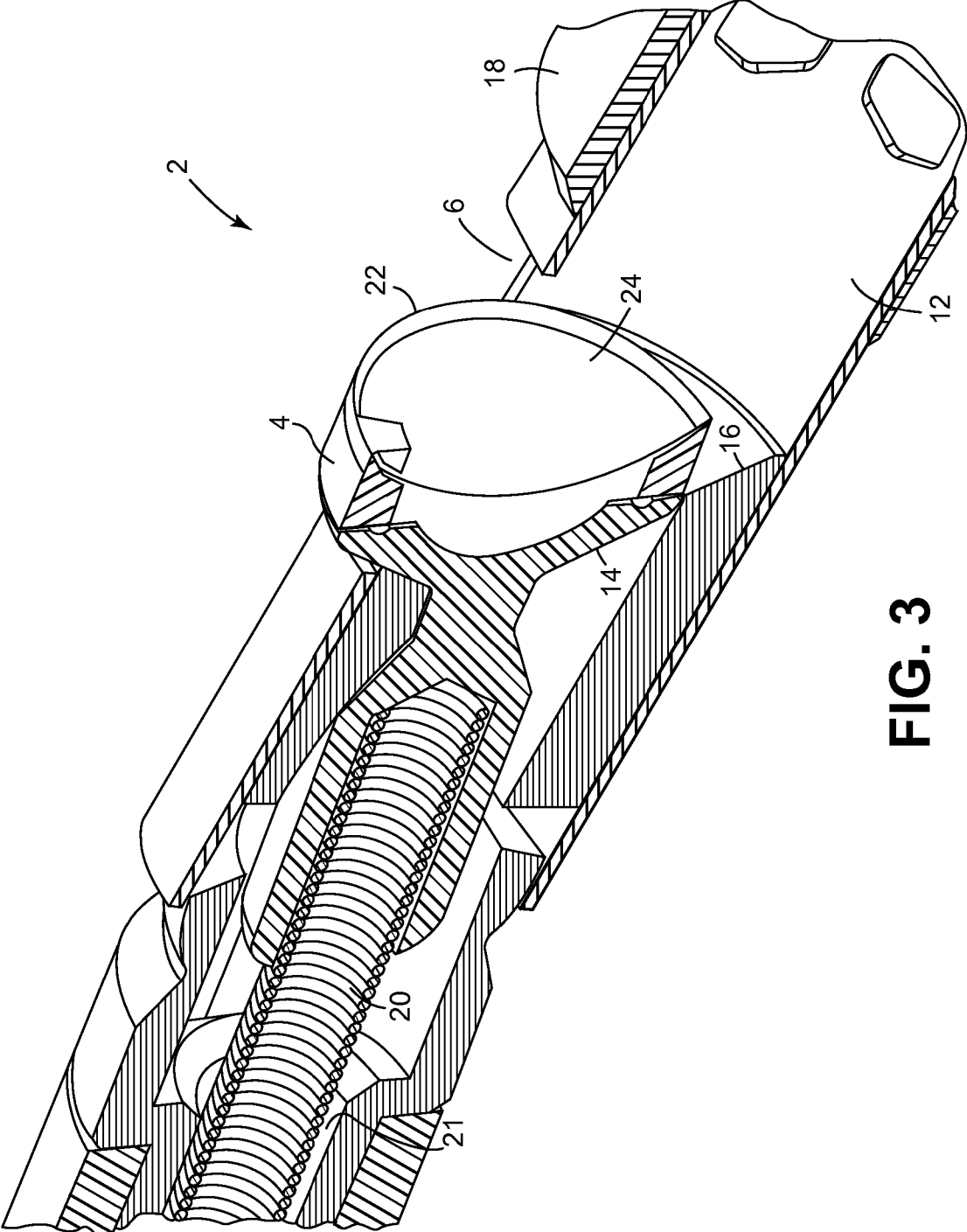

FIG. 3

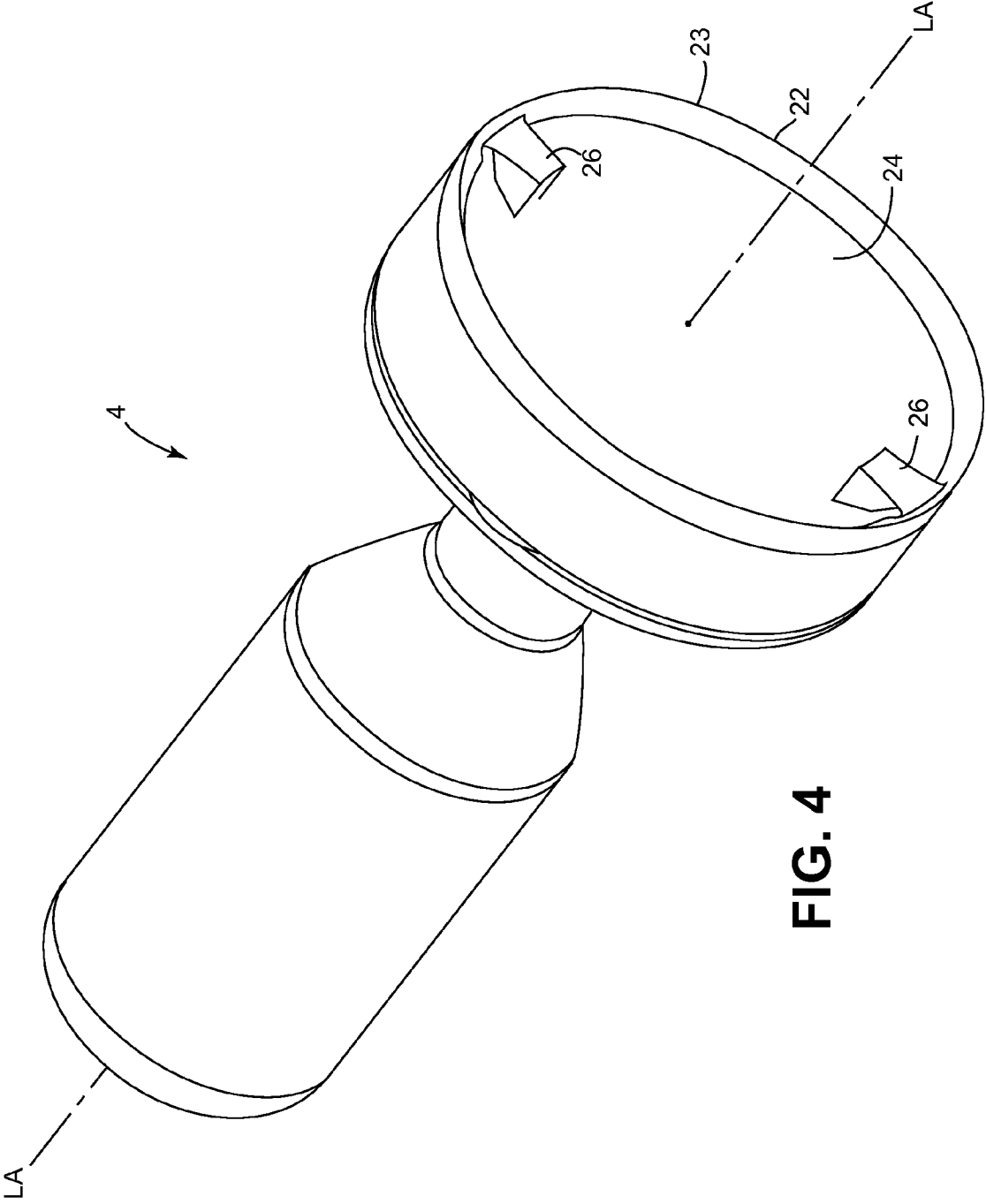
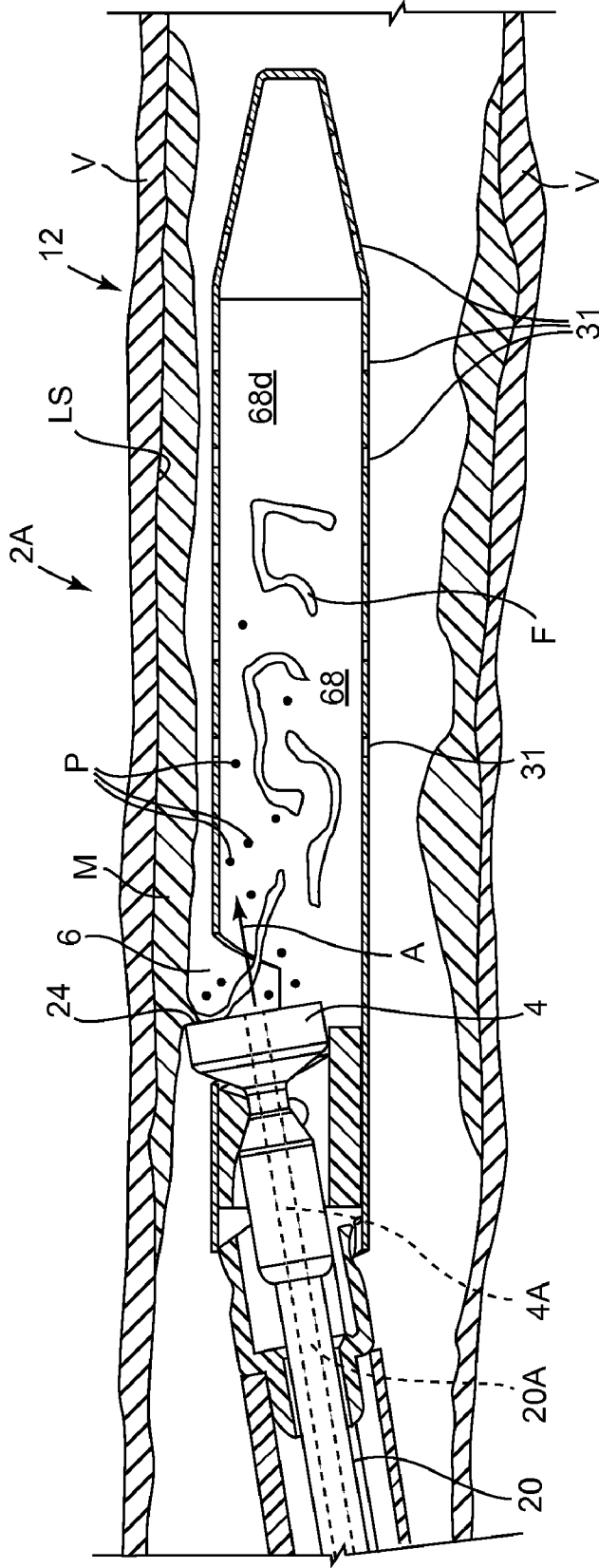

FIG. 4



**FIG. 5**

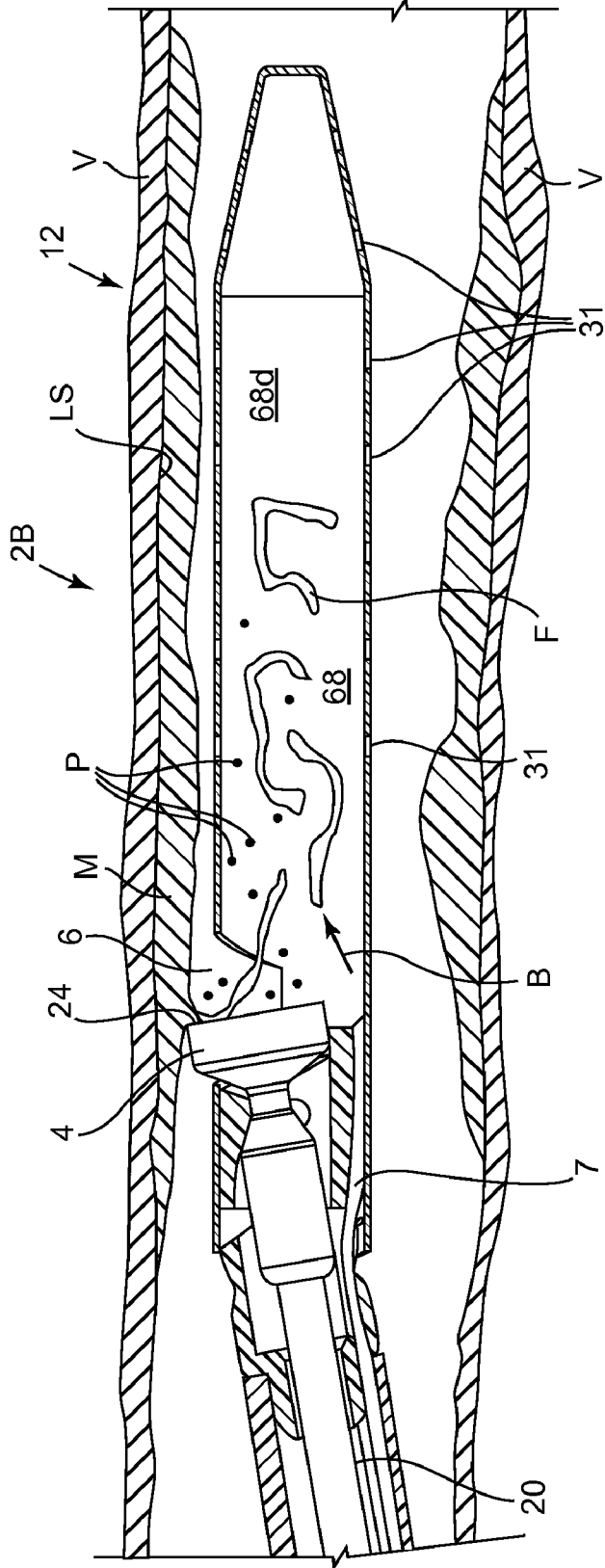

FIG. 6

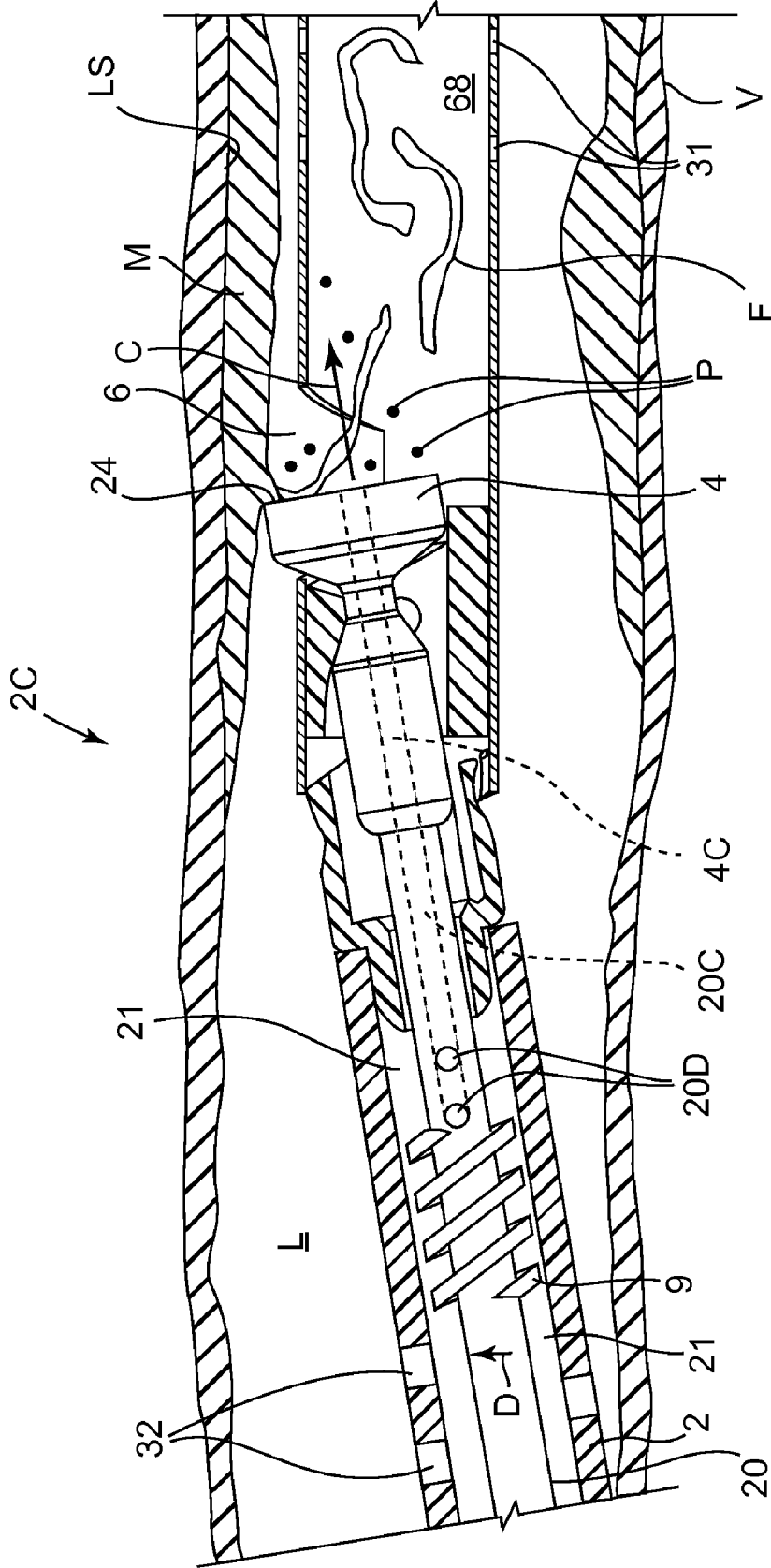
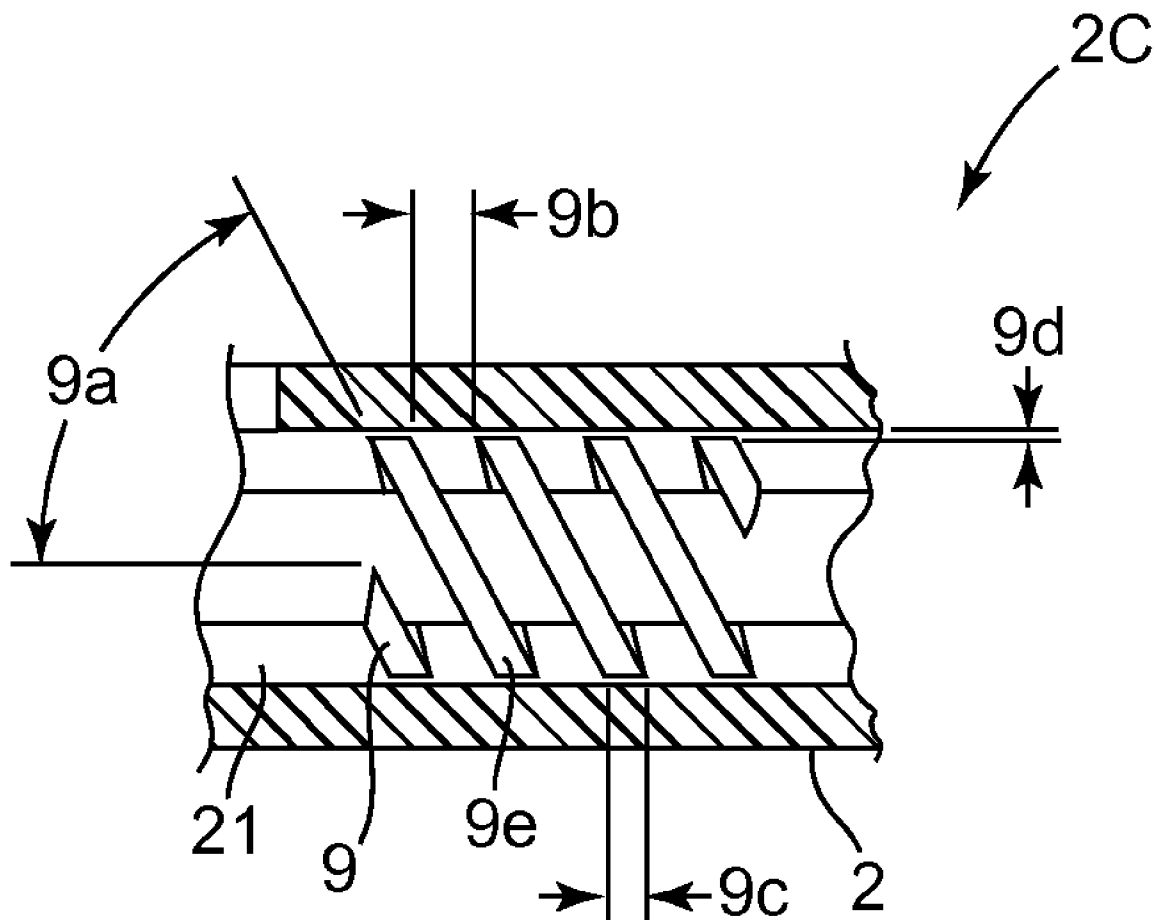

FIG. 7





**FIG. 7A**

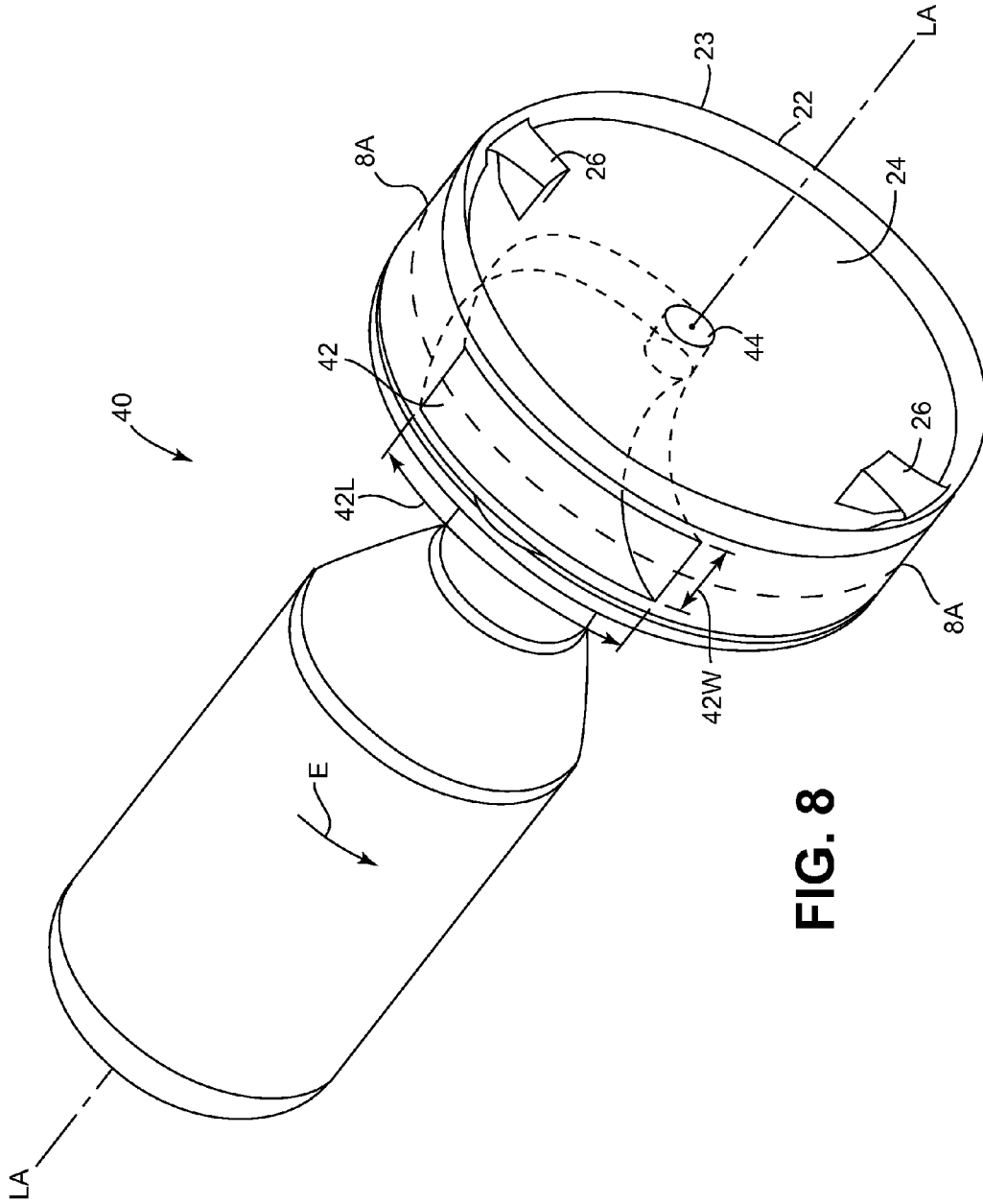
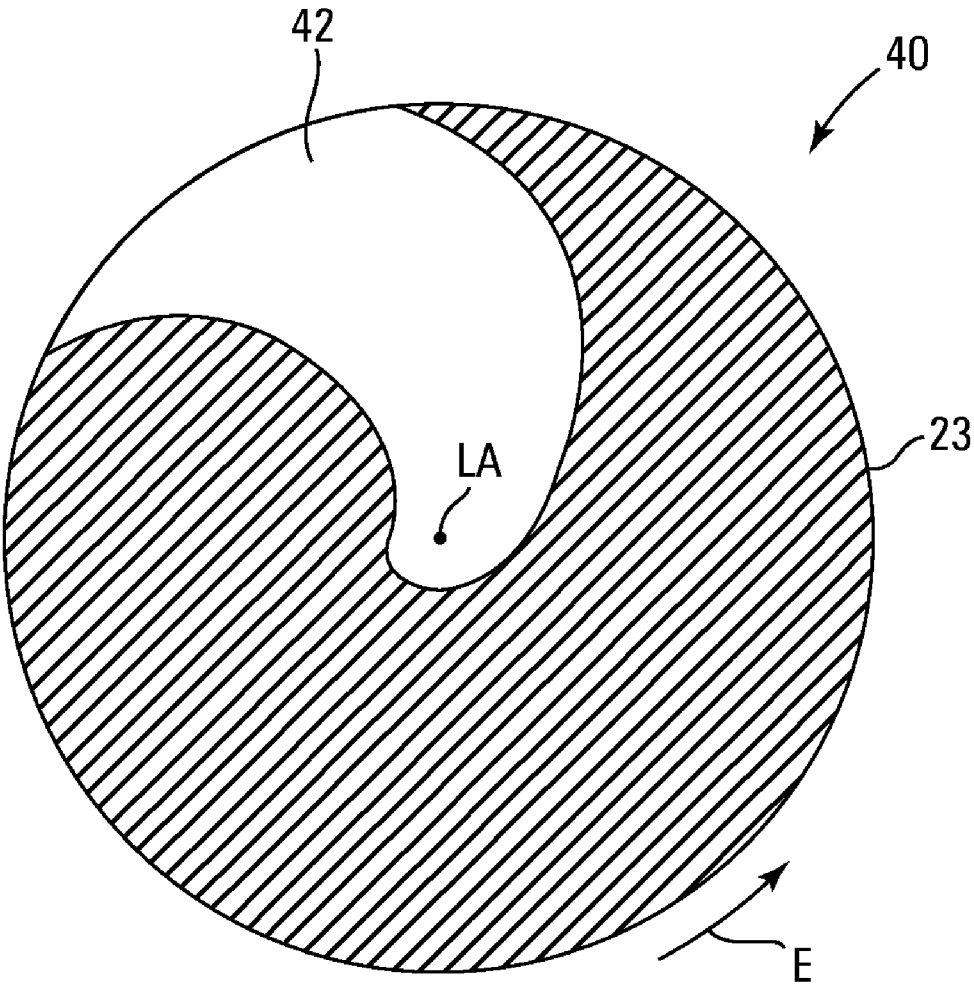

FIG. 8



**FIG. 8A**

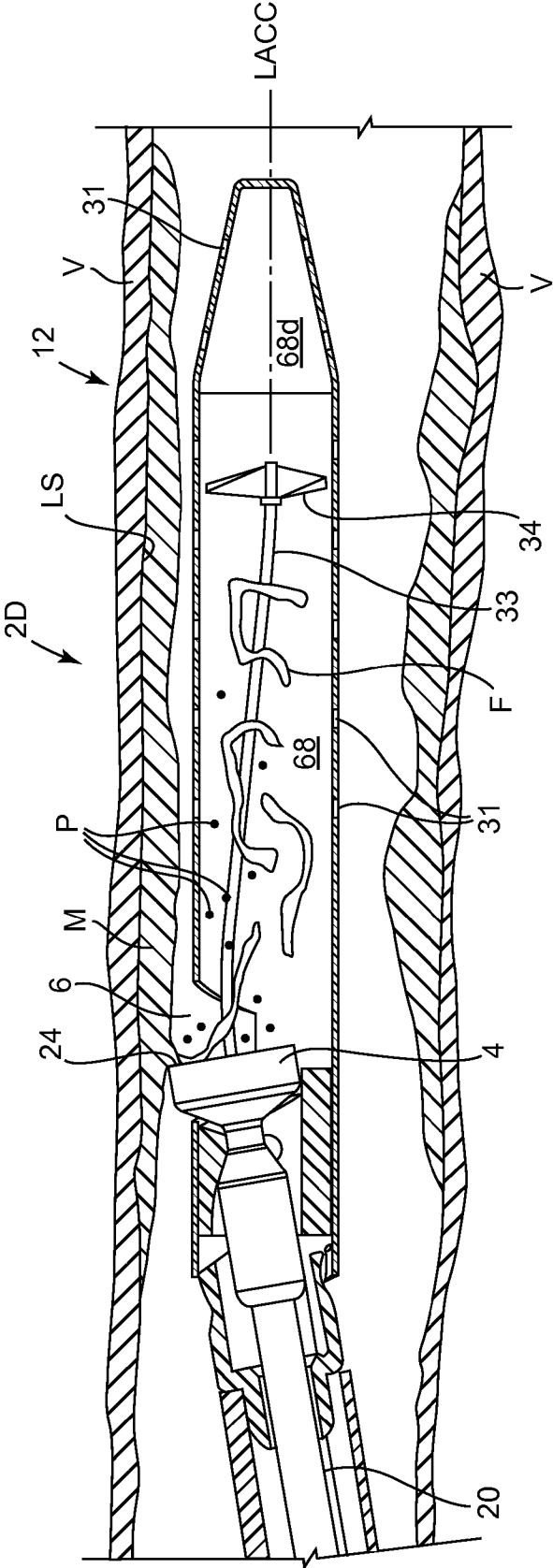
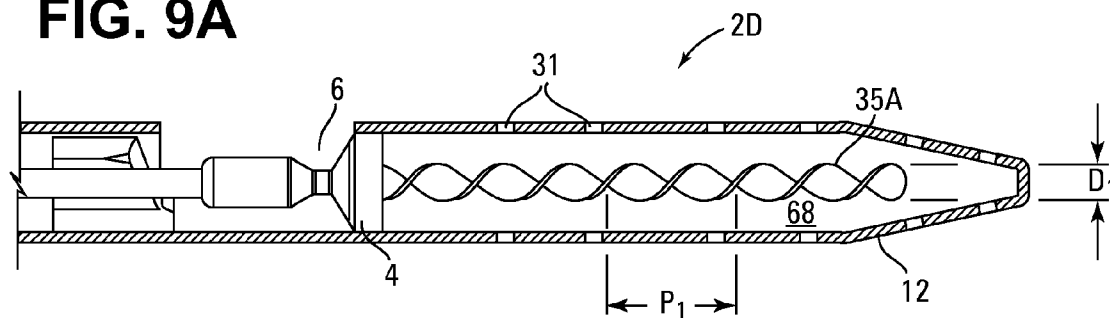
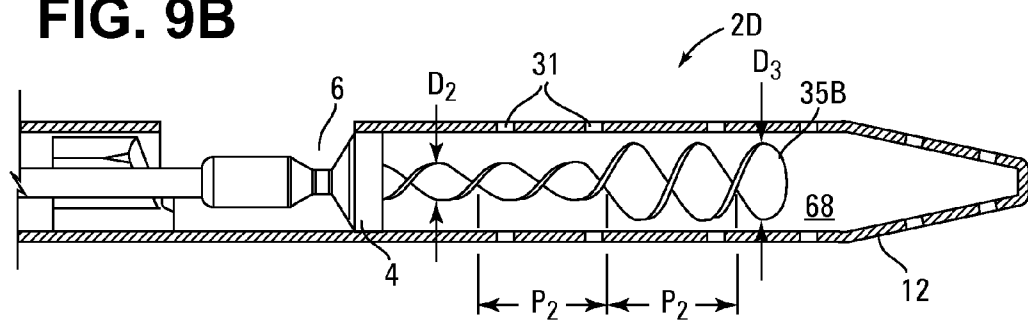

FIG. 9

**FIG. 9A**



**FIG. 9B**



**FIG. 9C**

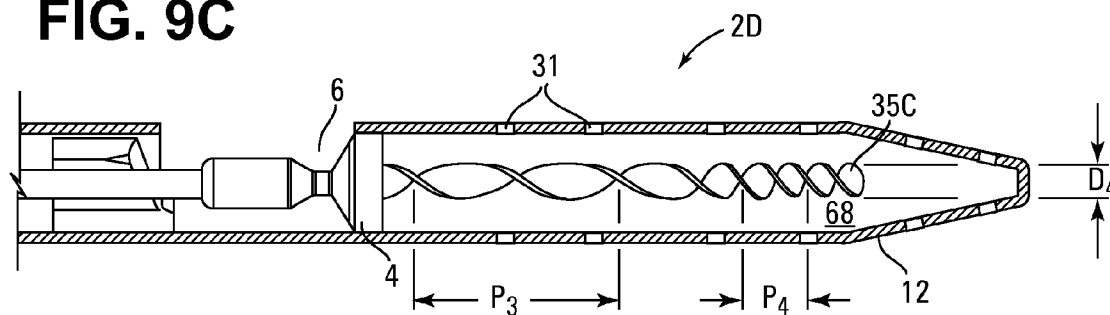



**MATERIAL REMOVAL DEVICE HAVING IMPROVED MATERIAL CAPTURE EFFICIENCY AND METHODS OF USE**

[0001] This application claims the benefit of U.S. Provisional Patent Application No. 61/285,768, filed Dec. 11, 2009, entitled “Material Removal Device Having Improved Material Capture Efficiency and Methods of Use”, the contents of which are hereby incorporated by reference herein.

**FIELD OF THE INVENTION**

[0002] The present invention relates to catheters used to remove material from a site in a body lumen. More particularly, this invention pertains to catheters capable of capturing the material removed from the site.

**BACKGROUND OF THE INVENTION**

[0003] Atherosclerosis is a progressive disease of the vascular system whereby atheroma is deposited on the inner walls of blood vessels. Over time atheromatous deposits can become large enough to reduce or occlude blood flow through the vessels, leading to symptoms of low blood flow such as pain in the legs (on walking or at rest), skin ulcer, angina (at rest or exertional), and other symptoms. To treat this disease and improve or resolve these symptoms it is desirable to restore or improve blood flow through the vessel.

[0004] Various means are used to restore or improve blood flow through atheromatous vessels. The atheroma deposits can be displaced by diametrically expanding the vessel by inflating balloons, expanding stents, and other methods, however these methods undesirably tear and stretch the vessel, causing scar formation in a high percentage of patients. Such scar tissue (restenotic material), once formed, blocks flow in the vessel and often needs to be removed. The deposits can be pulverized using lasers and other methods however pulverization alone of atheromatous material allows microemboli to flow downstream and lodge in distal vascular beds, further compromising blood flow to the tissue affected by the disease. Atherectomy catheters can be used to remove atheromatous deposits from the blood vessel and can present an ideal solution when the atheromatous debris removed from the vessel is captured and removed from the body.

[0005] One problem that occurs when removing material from a blood vessel is that material fragments may be created by the removal means, in some cases by a cutter, and such fragments may be left in the body where they can embolize and cause problems. It is desirable to remove from the body all material fragments created at the time of material removal from a vessel wall. Some catheters are designed to remove material from the body by directing material particles into a collection chamber however these collection efforts are not always 100% effective. Improved particle collection means are needed.

**SUMMARY OF THE INVENTION**

[0006] The invention provides an atherectomy catheter, comprising: a body having an opening; a rotatable shaft coupled to the body; a tissue collection chamber coupled to the body and positioned distal to the cutting element; a cutting element coupled to the rotatable shaft, the cutting element having a cutting edge; and a lumen configured to direct fluid into the tissue collection chamber.

[0007] The invention provides an atherectomy catheter, comprising: a body having an opening; a rotatable shaft coupled to the body; a tissue collection chamber coupled to the body and positioned distal to the cutting element; a cutting element coupled to the rotatable shaft, the cutting element having a cutting edge; and a part for propelling fluid distally in the tissue collection chamber, the part being selected from the group consisting of: (i) a drive shaft having a proximal end and a distal portion, the proximal end being attached to the cutting element and a propeller being attached to the distal portion; and (ii) a paddle attached to the cutting element.

[0008] The invention provides a method of recirculating fluid in an atherectomy catheter comprising: providing an atherectomy catheter, the atherectomy catheter comprising: a body having an opening; a rotatable shaft coupled to the body; a tissue collection chamber coupled to the body and positioned distal to the cutting element, the tissue collection chamber having vent holes; a cutting element coupled to the rotatable shaft, the cutting element having a cutting edge; and moving fluid out of the tissue collection chamber through the vent holes such that a negative pressure is created inside the tissue collection chamber and this negative pressure causing fluid to enter the tissue collection chamber through the opening of the body of the catheter.

[0009] The invention provides a method of removing material from a body lumen, the method comprising: providing an atherectomy catheter, the atherectomy catheter comprising: a body having an opening; a rotatable shaft coupled to the body; a tissue collection chamber coupled to the body and positioned distal to the cutting element; a cutting element coupled to the rotatable shaft, the cutting element having a cutting edge; and a lumen configured to direct fluid into the tissue collection chamber; placing the catheter in the body lumen; and moving the catheter in the body lumen to contact the cutting element with the material in the body lumen.

[0010] The invention provides a method of removing material from a body lumen, the method comprising: providing an atherectomy catheter, the atherectomy catheter comprising: a body having an opening; a rotatable shaft coupled to the body; a tissue collection chamber coupled to the body and positioned distal to the cutting element; a cutting element coupled to the rotatable shaft, the cutting element having a cutting edge; and a part for propelling fluid distally in the tissue collection chamber, the part being selected from the group consisting of: (i) a drive shaft having a proximal end and a distal portion, the proximal end being attached to the cutting element and a propeller being attached to the distal portion; and (ii) a paddle attached to the cutting element; placing the catheter in the body lumen; and moving the catheter in the body lumen to contact the cutting element with the material in the body lumen.

[0011] These and other aspects of the invention will become apparent from the following description of the preferred embodiments, drawings and claims. The details of one or more embodiments of the invention are set forth in the accompanying drawings and the description below. Other features, objects, and advantages of the invention will be apparent from the description and drawings, and from the claims.

**BRIEF DESCRIPTION OF THE DRAWINGS**

[0012] FIG. 1 illustrates a partial isometric view of an atherectomy catheter.

**[0013]** FIG. 2 illustrates an isometric cross-sectional view of a portion of the atherectomy catheter illustrated in FIG. 1 with a cutting element in a stored position.

**[0014]** FIG. 3 illustrates an isometric cross-sectional view of a portion of the atherectomy catheter illustrated in FIG. 1 with a cutting element in a working position.

**[0015]** FIG. 4 illustrates an isometric view of an embodiment of a cutting element.

**[0016]** FIGS. 5, 6 and 7 illustrate partial cross-sectional views of distal portions of embodiments of a catheter having improved material collection.

**[0017]** FIG. 7A illustrates a partial cross-sectional side view of a portion of the catheter illustrated in FIG. 7.

**[0018]** FIG. 8 illustrates an isometric view of another embodiment of a cutting element.

**[0019]** FIG. 8A illustrates a cross sectional view of the cutting element illustrated in FIG. 8.

**[0020]** FIG. 9 illustrates a partial cross-sectional view of a distal portion of an embodiment of a catheter having improved material collection.

**[0021]** FIGS. 9A, 9B and 9C illustrate partial cross-sectional side views of alternative components for the catheter illustrated in FIG. 9.

**[0022]** FIGS. 10A and 10B illustrate the catheter illustrated in FIG. 9 in use in a vessel.

#### DETAILED DESCRIPTION

**[0023]** The invention provides an atherectomy catheter, comprising: a body having an opening; a rotatable shaft coupled to the body; a tissue collection chamber coupled to the body and positioned distal to the cutting element; a cutting element coupled to the rotatable shaft, the cutting element having a cutting edge; and a lumen configured to direct fluid into the tissue collection chamber. In one embodiment, the lumen directs fluid in a distal direction into the tissue collection chamber. In one embodiment, the cutting element has a cup-shaped surface, the cup-shaped surface being configured to re-direct tissue cut by the cutting edge in a distal direction when the cup-shaped surface moves in the distal direction. In one embodiment, the lumen has a distal opening on the cup-shaped surface of the cutting element. In an embodiment, the lumen comprises a first lumen portion in the cutting element and a second lumen portion in the rotatable shaft. In one embodiment, the distal opening is positioned at a longitudinal axis of the cutting element. In an embodiment, the lumen has a distal opening and the distal opening is not positioned on the cup-shaped surface of the cutting element. In one embodiment, the distal opening is positioned adjacent to the cup-shaped surface of the cutting element.

**[0024]** In an embodiment, a fluid source that supplies fluid to the lumen is attached to a proximal portion of the catheter. In one embodiment, the fluid supplied by the fluid source is a saline solution. In one embodiment, the fluid supplied by the fluid source comprises a radiopaque substance.

**[0025]** In an embodiment, a proximal opening of the lumen is positioned at a distal portion of the catheter but proximal of the cup-shaped surface of the cutting element. In one embodiment, the proximal opening is positioned on the rotatable shaft. In one embodiment, the rotatable shaft comprises two or more proximal openings of the lumen. In an embodiment, the rotatable shaft comprises an impeller proximal of the proximal opening, the impeller forcing fluid into the proximal opening when the rotatable shaft is rotated. In one embodiment, the impeller has 1 to 10 turns. In one embodiment, the

lumen has a distal opening on the cup-shaped surface of the cutting element. In an embodiment, the distal opening is positioned at a longitudinal axis of the cutting element.

**[0026]** In one embodiment, a proximal opening of the lumen is positioned on the cutting element. In an embodiment, the proximal opening is positioned at an outer edge of the cutting element. In one embodiment, the cutting element has a cup-shaped surface, the cup-shaped surface being configured to re-direct tissue cut by the cutting edge in a distal direction when the cup-shaped surface moves in the distal direction, and the lumen has a distal opening on the cup-shaped surface of the cutting element. In an embodiment, the distal opening is positioned at a longitudinal axis of the cutting element.

**[0027]** In an embodiment, the tissue collection chamber comprises vent holes. In one embodiment, the tissue collection chamber comprises 10 to 200 vent holes. In an embodiment, the vent holes have a diameter of from 25 to 200 microns. In an embodiment, the cutting element is movable between a stored position and a cutting position relative to the opening.

**[0028]** The invention provides an atherectomy catheter, comprising: a body having an opening; a rotatable shaft coupled to the body; a tissue collection chamber coupled to the body and positioned distal to the cutting element; a cutting element coupled to the rotatable shaft, the cutting element having a cutting edge; and a part for propelling fluid distally in the tissue collection chamber, the part being selected from the group consisting of: (i) a drive shaft having a proximal end and a distal portion, the proximal end being attached to the cutting element and a propeller being attached to the distal portion; and (ii) a paddle attached to the cutting element. In one embodiment, the cutting element has a cup-shaped surface, the cup-shaped surface being configured to re-direct tissue cut by the cutting edge in a distal direction when the cup-shaped surface moves in the distal direction. In an embodiment, the part for propelling fluid distally in the tissue collection chamber is selected from the group consisting of: (i) a drive shaft having a proximal end and a distal portion, the proximal end being attached to the cup-shaped surface of the cutting element and a propeller being attached to the distal portion; and (ii) a paddle attached to the cup-shaped surface of the cutting element.

**[0029]** In an embodiment, the part for propelling fluid distally in the tissue collection chamber is a drive shaft having a proximal end and a distal portion, the proximal end being attached to the cutting element and a propeller being attached to the distal portion. In one embodiment, the propeller is located distally of the opening and proximally of the distal end of the collection chamber. In an embodiment, the propeller is located immediately distally of the opening. In an embodiment, the propeller is located in the distal half of the collection chamber. In one embodiment, the proximal end of the drive shaft is attached to a cup-shaped surface of the cutting element, the cup-shaped surface being configured to re-direct tissue cut by the cutting edge in a distal direction when the cup-shaped surface moves in the distal direction.

**[0030]** In an embodiment, the part for propelling fluid distally in the tissue collection chamber is a paddle attached to the cutting element. In an embodiment, the paddle is a wire that is twisted in a helical configuration. In an embodiment, the wire has a rectangular cross section. In an embodiment, the wire has a thickness from 0.002 to 0.020 inch (0.0051 to 0.051 cm). In one embodiment, wire width is from 0.010 to



0.075 inch (0.025 to 0.19 cm). In an embodiment, the paddle has a wire width that is from 20 to 95 percent of an inside diameter of the collection chamber. In an embodiment, the paddle has a longitudinal length that is at least 50 percent of the longitudinal length of the collection chamber. In an embodiment, the paddle has a longitudinal length that is at least 70 percent of the longitudinal length of the collection chamber. In an embodiment, the tissue collection chamber comprises vent holes. In one embodiment, the tissue collection chamber comprises 10 to 200 vent holes. In an embodiment, the vent holes have a diameter of from 25 to 200 microns. In an embodiment, the paddle is attached to a cup-shaped surface of the cutting element, the cup-shaped surface being configured to re-direct tissue cut by the cutting edge in a distal direction when the cup-shaped surface moves in the distal direction.

**[0031]** In one embodiment, the collection chamber comprises a portion at a distal end that can be opened to remove cut material and particles. In an embodiment, the cutting element is movable between a stored position and a cutting position relative to the opening.

**[0032]** The invention provides a method of recirculating fluid in an atherectomy catheter comprising: providing an atherectomy catheter, the atherectomy catheter comprising: a body having an opening; a rotatable shaft coupled to the body; a tissue collection chamber coupled to the body and positioned distal to the cutting element, the tissue collection chamber having vent holes; a cutting element coupled to the rotatable shaft, the cutting element having a cutting edge; and moving fluid out of the tissue collection chamber through the vent holes such that a negative pressure is created inside the tissue collection chamber and this negative pressure causing fluid to enter the tissue collection chamber through the opening of the body of the catheter. In one embodiment, the catheter comprises a lumen configured to direct fluid into the tissue collection chamber. In an embodiment, the catheter comprises a part for propelling fluid distally in the tissue collection chamber, the part being selected from the group consisting of: (i) a drive shaft having a proximal end and a distal portion, the proximal end being attached to the cutting element and a propeller being attached to the distal portion; and (ii) a paddle attached to the cutting element.

**[0033]** The invention provides a method of removing material from a body lumen, the method comprising: providing an atherectomy catheter, the atherectomy catheter comprising: a body having an opening; a rotatable shaft coupled to the body; a tissue collection chamber coupled to the body and positioned distal to the cutting element; a cutting element coupled to the rotatable shaft, the cutting element having a cutting edge; and a lumen configured to direct fluid into the tissue collection chamber; placing the catheter in the body lumen; and moving the catheter in the body lumen to contact the cutting element with the material in the body lumen. In one embodiment, the catheter is moved in a distal direction to contact the cutting edge with the material in the body lumen. In one embodiment, the catheter is placed in the body lumen with the cutting element in the stored position and the catheter is moved to contact the material with the cutting element in a cutting position. In one embodiment, the body lumen is a blood vessel.

**[0034]** The invention provides a method of removing material from a body lumen, the method comprising: providing an atherectomy catheter, the atherectomy catheter comprising: a body having an opening; a rotatable shaft coupled to the body;

a tissue collection chamber coupled to the body and positioned distal to the cutting element; a cutting element coupled to the rotatable shaft, the cutting element having a cutting edge; and a part for propelling fluid distally in the tissue collection chamber, the part being selected from the group consisting of: (i) a drive shaft having a proximal end and a distal portion, the proximal end being attached to the cutting element and a propeller being attached to the distal portion; and (ii) a paddle attached to the cutting element; placing the catheter in the body lumen; and moving the catheter in the body lumen to contact the cutting element with the material in the body lumen. In one embodiment, the catheter is moved in a distal direction to contact the cutting edge with the material in the body lumen. In one embodiment, the catheter is placed in the body lumen with the cutting element in the stored position and the catheter is moved to contact the material with the cutting element in a cutting position. In one embodiment, the body lumen is a blood vessel.

**[0035]** The present invention provides an improved atherectomy catheter having features for directing particles generated by a cutting element into a collection chamber. Methods of directing the cut material from a blood vessel lumen into a collection chamber are also provided. The cutting element has a sharp cutting edge that surrounds a cup-shaped surface. Cut material is directed into the collection chamber by the cup-shaped surface and by fluid flow.

**[0036]** Referring to FIGS. 1 to 4, an atherectomy catheter 2 is shown which has a cutting element 4, which is used to cut material from a blood flow lumen such as a blood vessel. The cutting element 4 is movable between a stored position (FIG. 2) and a cutting position (FIG. 3) relative to an opening 6 in a body 8 of the catheter 2. The cutting element 4 moves outwardly relative to the opening 6 so that a portion of the element 4 extends outwardly from the body 8 through the opening 6. In one embodiment the cutting element 4 may be positioned relative to the body 8 and opening 6 so that less than 90 degrees of the cutting element 4 is exposed to cut tissue. In other embodiments more of the cutting element 4 may be exposed without departing from numerous aspects of the invention.

**[0037]** Distal end of catheter 2 is positioned near a treatment site of a vessel with cutting element 4 in the stored position. Then catheter 2 is moved distally through the vessel with the cutting element 4 in the working or cutting position as described in further detail below. As the catheter 2 moves through the blood vessel with the cutting element 4 in the working or cutting position the tissue material is cut by the cutting element 4 and is directed into a tissue chamber 12 positioned distal to the cutting element 4. The tissue chamber 12 may be somewhat elongated to accommodate the tissue which has been cut.

**[0038]** To expose cutting element 4 through opening 6, cutting element 4 is moved proximally from the stored position so that a cam surface 14 on the cutting element 4 engages a ramp 16 on the body 8 of the catheter 2. The interaction between the cam surface 14 and the ramp 16 causes the cutting element 4 to move to the cutting position and also causes a tip 18 to deflect which tends to move the cutting element 4 toward the tissue to be cut.

**[0039]** The cutting element 4 has a cup-shaped surface 24, which directs the tissue cut by the cutting edge 22 into the tissue chamber 12. Cutting edge 22 may be at a radially outer edge 23 of the cutting element 4. In some embodiments the cup-shaped surface 24 may be a smooth and continuous sur-

face free of through holes, teeth, fins or other features, which disrupt the smooth nature of the surface 24 for at least half the distance from the longitudinal axis LA to the outer radius at the cutting edge 22. In some embodiments the cup-shaped surface 24 may also be free of any such features throughout an area of at least 300 degrees relative to the longitudinal axis LA. In other embodiments the cup-shaped surface may have a limited amount of through holes, teeth, fins or other features as described in further detail below. One or more raised elements 26 may extend outwardly from the cup-shaped surface 24 with FIG. 4 showing two raised elements 26. The raised element 26 is a small wedge of material that rises relatively abruptly from the cup-shaped surface 24. The raised element 26 helps to break up hard tissue and plaque by applying a relatively blunt striking force to the hard tissue or plaque since cutting such tissue with the cutting edge 22 may not be effective, and strips of such hard tissue may not be flexible enough to be redirected by cup-shaped surface 24 into collection chamber 12. The raised elements 26 altogether occupy a relative small part of the cup-shaped surface 24. By sizing and positioning the raised elements 26 in this manner, the raised elements 26 do not interfere with the ability of the cutting element 4 cup-shaped surface 24 to cut and re-direct large strips of tissue into the tissue chamber while still providing the ability to break up hard tissue and plaque with raised element 26.

[0040] The cutting element 4 is coupled to a shaft 20 that extends through a lumen 21 in the catheter 2. Catheter 2 is coupled to exemplary cutter driver 5. Cutter driver 5 is comprised of motor 11, power source 15 (for example one or more batteries), microswitch (not shown), housing 17 (upper half of housing is removed as shown), lever 13 and connection assembly (not shown) for connecting shaft 20 to driver motor 11. Cutter driver 5 can act as a handle for the user to manipulate catheter 2. Lever 13, when actuated to close the microswitch, electrically connects power source 15 to motor 11 thereby causing rotation of cutting element 4. The cutting element 4 is rotated about a longitudinal axis LA when the shaft 20 rotates. The cutting element 4 is rotated at about 1 to 160,000 rpm but may be rotated at any other suitable speed depending upon the particular application. Further description of catheters similar to catheter 2 is found in U.S. Patent Application Publication No. U.S. 2002/0077642 A1 to Patel et. al., entitled "Debulking Catheter", the contents of which are hereby incorporated by reference herein.

[0041] In use, catheter 2 cuts softer atheroma from a vessel wall in relatively large strips and cup-shaped surface 24 directs these strips through opening 6 into collection chamber 12. Smaller particles, in some cases produced during the removal of harder or calcified atheroma, can be directed towards opening 6 by the cup-shaped surface 24 and can also be directed tangentially to the spinning cutting element outer edge 23, in some cases past opening 6 and in this event not collected in chamber 12.

[0042] Referring now to FIG. 5, catheter 2A is shown wherein the same or similar reference numbers of catheter 2A refer to the same or similar structures of catheter 2 and all discussion concerning the same or similar features of catheter 2 are equally applicable here unless noted otherwise. Compared to catheter 2, catheter 2A has improved material collection capability and is additionally comprised of lumen 4A in cutting element 4, lumen 20A in connecting shaft 20, rotating fitting at cutter driver 5 (not shown), fluid source (not shown) and vent holes 31 in wall of collection chamber 12.

Cutting element 4 and connecting shaft 20 are attached by bonding, welding, molding, pressure fit, gasketed mechanical seal, or other means so as to form a leak-tight fluid connection between lumens 4A and 20A. Rotating fitting at cutter driver 5 is attached to connecting shaft 20 and to fluid source in a similar manner so as to form a fluid tight connection between the fluid source and rotating connecting shaft 20. In some embodiments lumen diameters and lengths are sized so as to permit fluid flow rates of 0.5 to 50 cc/min, including 0.5, 1, 2, 5, 10, 20, or 50 cc/min, or other flow rates at a driving pressure of 50 psi (345 kilopascal). In other embodiments these flow rates are achieved at driving pressures of 1, 5, 10, 20, 100 or 150 psi (6.9, 35, 69, 140, 690, or 1000 kilopascal), or at pressures therebetween.

[0043] Vent holes 31 allow fluid to flow out of interior 68 of collection chamber 12 without allowing significant particles of material to pass therethrough. In one embodiment, vent hole diameter is 50 microns. In other embodiments vent hole diameter is from 25 to 200 microns, including 25, 35, 65, 80, 100, 150 or 200 microns. The number, spacing and distribution of vent holes 31 can vary. In various embodiments, 10 to 200 vent holes are contemplated and the number of vent holes can be from 10 to 200, including 10, 20, 30, 50, 75, 100, or 200. The holes can be uniformly or non-uniformly distributed over the outer surface of collection chamber 12. In one embodiment more than half of the holes are distributed over the proximal half of the outer surface of collection chamber 12 so that flow from interior 68 of collection chamber 12 is preserved as holes of the collection chamber become blocked by particles and fragments. In another embodiment, to encourage fluid to preferentially flow out of vent holes 31 as opposed to out of opening 6, the aggregate hydraulic resistance of fluid passing through all vent holes is less than the hydraulic resistance of fluid passing through opening 6.

[0044] In operation, catheter 2A is advanced through vessel V with cutting element 4 exposed through opening 6. Cutting element 4 separates large fragments F of atheromatous material M from luminal surface LS of vessel V and cup-shaped surface 24 of cutting element 4 directs said fragments through opening 6 into interior 68 of collection chamber 12. The fluid source forces pressurized fluid (such as physiological saline solution) through lumens 20A, 4A before, during or after rotation of cutting element 4, or any combination of before, during or after rotation of cutting element 4. Fluid exits lumen 4A of cutting element 4 in direction of arrow A and flows into interior 68 of collection chamber 12 and out of vent holes 31. Small particles P, generated by cutting element 4 acting on material M, are carried by fluid flow into distal region 68d of interior 68 of collection chamber 12.

[0045] Referring to FIG. 6, another catheter 2B is shown wherein the same or similar reference numbers of catheter 2B refer to the same or similar structures of catheter 2 and all discussion concerning the same or similar features of catheter 2 are equally applicable here unless noted otherwise. Compared to catheter 2, catheter 2B has improved material collection capability and is additionally comprised of tube 7, fluid source (not shown) and vent holes 31 in wall of collection chamber 12. Tube 7 is attached to the fluid source with a leak-tight fluid connection such as a gasketed mechanical seal in the vicinity of cutter driver 5. The fluid source, in some embodiments, provides flow only when cutter 4 is rotating, for example by means of a valve, so as to prevent infusion of excessive fluid into a patient. The fluid source can provide flow before, during or after rotation of cutting element 4, or

any combination of before, during or after rotation of cutting element 4. In other embodiments the fluid is comprised of radiopaque substances, such as contrast media, to facilitate visualization of the amount of material within collection chamber 12. The distal end of tube 7 can be oriented in any direction ranging from towards the side wall of collection chamber 12 to towards the distalmost end of collection chamber 12. In one embodiment the distal end of tube 7 is oriented towards distal region 68d of interior 68 of collection chamber 12. In other embodiments tube 7 has a one way valve that allows flow distally through the tube but prevents flow proximally through the tube so as to prevent blood or debris from entering tube 7 and potentially clogging the lumen of tube 7. In some embodiments the lumen diameter and length of tube 7 are sized so as to permit fluid flow rates of 0.5 to 50 cc/min, including 0.5, 1, 2, 5, 10, 20, or 50 cc/min, or other flow rates at a driving pressure of 50 psi (345 kilopascal). In other embodiments these flow rates are achieved at driving pressures of 1, 5, 10, 20, 100 or 150 psi (6.9, 35, 69, 140, 690, or 1000 kilopascal), or at pressures therebetween. Vent holes 31 have structure and functional characteristics as described above for catheter 2A.

[0046] In another embodiment of catheter 2B, fluid is infused through lumen 21 of catheter 2 instead of being infused through the lumen of tube 7. In this embodiment fluid passages (not shown) can be provided in ramp 16 such that fluid will flow distally through ramp 16 and exit from ramp 16 into interior 68 of collection chamber 12.

[0047] In operation, catheter 2B is advanced through vessel V with cutting element 4 exposed through opening 6. Cutting element 4 separates large fragments F of atheromatous material M from luminal surface LS of vessel V and cup-shaped surface 24 of cutting element 4 directs said fragments through opening 6 into interior 68 of collection chamber 12. The fluid source forces pressurized fluid (such as physiological saline solution) through tube 7 before, during or after rotation of cutting element 4, or any combination of before, during or after rotation of cutting element 4. In some embodiments the fluid is comprised of radiopaque dye and the amount of plaque in the tip is visualized. Fluid exits the lumen of tube 7 in the direction of arrow B and flows into interior 68 of collection chamber 12 and out of vent holes 31. Small particles P, generated by cutting element 4 acting on material M, are carried by fluid flow into distal region 68d of interior 68 of collection chamber 12.

[0048] Referring to FIG. 7, another catheter 2C is shown wherein the same or similar reference numbers of catheter 2C refer to the same or similar structures of catheter 2 and all discussion concerning the same or similar features of catheter 2 are equally applicable here unless noted otherwise. Compared to catheter 2, catheter 2C has improved material collection capability and is additionally comprised of lumen 4C in cutting element 4, lumen 20C and holes 20D in connecting shaft 20, impeller 9, inlet holes 32 in catheter 2 and vent holes 31 in the wall of collection chamber 12. Cutting element 4 and connecting shaft 20 are attached by bonding, welding, molding, pressure fit, gasketed mechanical seal, or other means so as to form a leak-tight fluid connection between lumens 4C and 20C. Holes 32 allow passage of fluid from lumen L of vessel V into lumen 21 and holes 20D allow passage of fluid from lumen 21 into lumen 20C. In some embodiments lumen diameters and lengths are sized so as to permit fluid flow rates of 0.5 to 50 cc/min, including 0.5, 1, 2, 5, 10, 20, or 50 cc/min, or other flow rates at a driving pressure of 50 psi (345 kilo-

pascal). In other embodiments these flow rates are achieved at driving pressures of 1, 5, 10, 20, 100 or 150 psi (6.9, 35, 69, 140, 690, or 1000 kilopascal), or at pressures therebetween. Impeller 9 is fixedly attached to connecting shaft 20 by adhesive bond, welding, mechanical interlock, or other means.

[0049] Referring to FIG. 7A, impeller 9 is comprised of metal, plastic, or other materials including but not limited to stainless steel, nitinol, polyoxymethylene (commercially available under the trade designation DELRIN®), polyether block amide (commercially available under the trade designation PEBAX®), polyamide, nylon 12, polyester, or other materials. Impeller 9 may be a separately fabricated component that is attached to connecting shaft 20 by welding, adhesive bond, or other means, or may be integrally formed from the shaft. In some embodiments the impeller is comprised of 1 to 10 or more turns, including 1, 2, 3, 4, 6, 8, or 10 turns (four turns 9e are illustrated in FIG. 7A). Pitch angles 9a of 10 to 75 degrees, including 10, 20, 30, 45, 60 or 75 degrees, are contemplated and pitch spacing 9b may be uniform or varied along the length of impeller. Impeller land width 9c may also vary along the length of the impeller. In some embodiments clearance 9d between the outer diameter of impeller 9 and inner diameter of catheter 2 may be from 0.000 to 0.010 inch (0.000 to 0.025 cm), including 0.000, 0.001, 0.002, 0.003, 0.004, 0.007 or 0.010 inch (0.000, 0.0025, 0.0051, 0.0076, 0.010, 0.018 or 0.025 cm) or in amounts therebetween. In other embodiments there may be an interference fit or negative clearance 9d between the outer diameter of impeller 9 and inner diameter of catheter 2 in the amount of from 0.0005 to 0.002 inch (0.0013 to 0.0051 cm), including 0.0005, 0.001 or 0.002 inch (0.0013, 0.0025 or 0.0051 cm) or in amounts therebetween. In further embodiments dimensions of impeller 9 and diameter of lumen 21 may be varied so as to generate fluid flow rates of 0.5 to 50 cc/min, including 0.5, 1, 2, 5, 10, 20, or 50 cc/min, or other flow rates when the impeller is rotating at 1,000, 2,000, 4,000, 8,000, 16,000 or 24,000 RPM or at rotational speeds therebetween. Vent holes 31 have structure and functional characteristics as described above for catheter 2A.

[0050] In operation, catheter 2C is advanced through vessel V with cutting element 4 exposed through opening 6. Cutting element separates large fragments F of atheromatous material M from luminal surface LS of vessel V and cup-shaped surface 24 of cutting element 4 directs said fragments through opening 6 into interior 68 of collection chamber 12. Impeller 9, rotating in the direction indicated by arrow D, draws fluid (such as blood) from lumen L of vessel through holes 32 and into lumen 21, pressurizes the fluid and forces the pressurized fluid through holes 20D, lumen 20C and lumen 4C during rotation of cutting element 4. Fluid exits lumen 4C of cutting element 4 in the direction of arrow C and flows into interior 68 of collection chamber 12 and out of vent holes 31. Small particles P, generated by cutting element 4 acting on material M, are carried by fluid flow into distal region 68d of interior 68 of collection chamber 12.

[0051] Cutting element 40 (see FIGS. 8 and 8A) can be used in place of cutting element 4 in any of catheters 2, 2A, 2B, 2C or 2D. Cutting element 40 is similar to cutting element 4 wherein the same or similar reference numbers of cutting element 40 refer to the same or similar structures of cutting element 4 and all discussion concerning the same or similar features of cutting element 4 are equally applicable here unless noted otherwise. Compared to cutting element 4, cutting element 40 is additionally comprised of one or more

channels 42 and one or more holes 44. During rotation of cutting element 40 in direction E fluid (such as blood) enters channel 42 at outer edge 23 of cutting element 40 and exits distally through hole 44. Channel 42 and hole 44 can be fabricated into cutter 40 by drilling, electro-discharge machining (EDM), or other means. In one embodiment, cutting element 40 is made in 2 pieces, one with channel 42 cut therein, the other with cutting edge 22, cup-shaped surface 24, raised element 26 (if used) and hole 44 formed therein, the two pieces being subsequently joined together by welding, soldering, brazing, adhesive bonding, mechanical interlock or other means. In some embodiments holes 44 are not positioned along axis LA of cutting element 40. The number of channels and holes, channel widths 42W, channel lengths 42L, and hole 44 diameters may be varied so as to generate fluid flow rates of 0.5 to 50 cc/min, including 0.5, 1, 2, 5, 10, 20 or 50 cc/min, or other flow rates when cutting element 40 is rotating at 1,000, 2,000, 4,000, 8,000, 16,000 or 24,000 RPM or at rotational speeds therebetween.

**[0052]** In operation, cutting element 40 is rotated in the direction of arrow E during use within a vessel V as previously described for, for example, catheter 2A. Cutting element 40 separates large fragments F of atheromatous material M from luminal surface LS of vessel V and cup-shaped surface 24 of cutting element 4 directs said fragments through opening 6 into interior 68 of collection chamber 12. Cutting element 40, rotating in the direction indicated by arrow E, forces fluid (such as blood) from lumen L of vessel V into channel 42 and into hole 44 during rotation of the cutting element. Fluid exits hole 44 of cutting element 40 in the general direction of longitudinal axis LA and flows into interior 68 of collection chamber 12 and out of vent holes 31. Small particles P, generated by cutting element 40 acting on material M, are carried by fluid flow into distal region 68d of interior 68 of collection chamber 12.

**[0053]** Referring to FIG. 9, another catheter 2D is shown wherein the same or similar reference numbers of catheter 2D refer to the same or similar structures of catheter 2 and all discussion concerning the same or similar features of catheter 2 are equally applicable here unless noted otherwise. Compared to catheter 2, catheter 2D has improved material collection capability and is additionally comprised of drive shaft 33 and one or more propellers 34. In various embodiments drive shaft 33 and propeller 34 may be comprised of metals such as stainless steel, cobalt-chromium-nickel-molybdenum-iron alloy (commercially available under the trade designation Elgiloy®), or other metals, or polymers such as polyester, polyamide, nylon 12, liquid crystal polymer, or other polymers. Drive shaft 33 is attached to cup-shaped surface 24 of cutting element 4 and propeller 34 is attached to drive shaft 33, in some embodiments by welding, brazing, soldering, overmolding, mechanical interlock, adhesive bonding or other attachment means. In one embodiment, drive shaft 33 is attached to cup-shaped surface 24 of cutting element 4 along longitudinal axis LA. Drive shaft 33 is flexible enough to bend between axis LA of cutting element and the longitudinal axis LACC of collection chamber 12. In one embodiment (FIG. 9) drive shaft 33 is long enough to locate propeller 34 near the distal end of collection chamber 12. In another embodiment (FIG. 10A) drive shaft 33 is only long enough to locate propeller 34 immediately distal to opening 6. Drive shaft 33 may be of any length at or between these two extremes. Propeller 34 is oriented to propel fluid (for example, blood) in a distal direction. The pitch of propeller 34

may be varied so as to generate fluid flow rates of 0.5 to 50 cc/min, including 0.5, 1, 2, 5, 10, 20 or 50 cc/min, or other flow rates when propeller 34 is rotating at 1,000, 2,000, 4,000, 8,000, 16,000 or 24,000 RPM or at rotational speeds therebetween. Vent holes 31 have structure and functional characteristics as described above for catheter 2A.

**[0054]** In operation, catheter 2D is advanced through vessel V with cutting element 4 exposed through opening 6. Cutting element 4 separates large fragments F of atheromatous material M from luminal surface LS of vessel V and cup-shaped surface 24 of cutting element 4 directs said fragments through opening 6 into interior 68 of collection chamber 12. Propeller 34 propels fluid distally in interior 68 of collection chamber 12 and out through vent holes 31, thereby causing fluid (such as blood) to be drawn into collection chamber 12 through opening 6. Fluid flow into opening 6 carries small particles P, generated by cutting element 4 acting on material M, into distal region 68d of interior 68 of collection chamber 12.

**[0055]** In another embodiment of catheter 2D, a paddle is attached to cup-shaped surface 24 of cutting element 4 instead of attaching drive shaft 33 and propeller 34 to cup-shaped surface 24. Some embodiments of a paddle are illustrated in FIGS. 9A, 9B and 9C and labeled as paddles 35A, 35B and 35C, respectively. The paddles 35A, 35B, 35C are illustrated with cutter 4 in a stored position. The paddles may be comprised of wire having, in some embodiments, a rectangular cross section. The wire is twisted into a helical configuration as shown in the figures. Paddles 35A, 35B, or 35C cause fluid in interior 68 of chamber 12 to move distally during rotation of cutting element 4. In some embodiments wire width (the maximum distance between portions of the wire in the plane perpendicular to the longitudinal axis of the catheter), length and thickness as well as the pitch of the helix may be varied so as to generate fluid flow rates of 0.5 to 50 cc/min, including 0.5, 1, 2, 5, 10, 20, or 50 cc/min, or other flow rates when the impeller is rotating at 1,000, 2,000, 4,000, 8,000, 16,000 or 24,000 RPM or at rotational speeds therebetween. In some embodiments the wire may be from 0.002 to 0.020 inch (0.0051 to 0.051 cm), including 0.002, 0.003, 0.004, 0.005, 0.007, 0.009, 0.011, 0.015 or 0.020 inch (0.0051, 0.0076, 0.010, 0.013, 0.018, 0.023, 0.028, 0.038 or 0.051 cm) thick, and the wire width may be from 0.010 to 0.075 inch (0.025 to 0.19 cm), including 0.010, 0.015, 0.020, 0.025, 0.030, 0.040, 0.050 or 0.075 (0.025, 0.038, 0.051, 0.064, 0.076, 0.10, 0.13 or 0.19 cm), or at thicknesses, wire widths, or both therebetween.

**[0056]** In one exemplary embodiment, FIG. 9A illustrates paddle 35A comprised of rectangular cross section wire that has been twisted into a helix that is nearly as long as the length of collection chamber 12, having a wire width D1 that is 40% of the inside diameter of the collection chamber, and which has a uniform pitch length P1 over the length of the paddle. In another exemplary embodiment, FIG. 9B illustrates paddle 35B comprised of rectangular cross section wire that has been twisted into a helix that is 60% as long as the length of collection chamber 12, having a wire width D2 over the proximal portion of the paddle that is 40% of the inside diameter of the collection chamber and a wire width D3 over the distal portion of the paddle that is 80% of the inside diameter of the collection chamber, and which has a uniform pitch length P2 over the length of the paddle. It is contemplated that other embodiments can have 3 or more different wire widths, or that the wire width may continuously vary over at least portions of paddle 35B. Further, wire widths of

from 20% of the inside diameter of the collection chamber to 95% of the inside diameter of the collection chamber are contemplated. FIG. 9C illustrates paddle 35C comprised of rectangular cross section wire that has been twisted into a helix that is 70% as long as the length of collection chamber 12, having a wire width D4 over the length of the paddle that is 30% of the inside diameter of the collection chamber, and a pitch length P3 over a proximal portion of paddle and a pitch length P4 over a distal portion of the paddle. It is contemplated that other embodiments can have 3 or more pitch lengths, or that the pitch length may continuously vary over at least portions of paddle 35C. In yet other embodiments, wire width and pitch length can both vary continuously or discretely over the length of a paddle.

[0057] Optionally, in some embodiments catheters 2, 2A, 2B or 2C may additionally be comprised of drive shaft 33 and propeller 34. In other embodiments catheters 2, 2A, 2B or 2C may additionally be comprised of paddles 35A, 35B, or 35C.

[0058] In operation, catheter 2D equipped with paddle 35A, 35B, or 35C, instead of shaft 33 and propeller 34, is advanced through vessel V with cutting element 4 exposed through opening 6. Cutting element 4 separates large fragments F of atheromatous material M from luminal surface LS of vessel V and cup-shaped surface 24 of cutting element 4 directs said fragments through opening 6 into interior 68 of collection chamber 12. Paddle 35A, 35B, or 35C propels fluid distally in interior 68 of collection chamber 12 and out through vent holes 31, thereby causing fluid (such as blood) to be drawn into collection chamber 12 through opening 6. Fluid flow into opening 6 carries small particles P, generated by cutting element 4 acting on material M, into distal region 68d of interior 68 of collection chamber 12. Paddle 35 also transports fragments F into distal region 68d of interior 68 of collection chamber 12.

[0059] In another embodiment, fragments F and particles P are removed from interior 68 of collection chamber 12 of catheter 2D by providing an opening at the distal end of collection chamber 12 and then rotating propeller 34 or paddle 35 to thereby expel debris. Further description of catheters provided with an opening at the distal end of collection chamber 12 is found in U.S. Patent Application Publication No. U.S. 2005/0222663 A1 to Simpson et. al., entitled "Debulking Catheters and Methods", the contents of which are hereby incorporated by reference herein. See paragraphs [0117] to [0146]. In other embodiments catheters 2, 2A, 2B or 2C may additionally be comprised of shaft 33 and propeller 34 or paddles 35A, 35B, or 35C and the interior of collection chamber 12 may be cleaned of debris as described above for catheter 2D.

[0060] In some embodiments of catheters 2A, 2B, 2C or 2D a fluid recirculation circuit may be established. This is especially desirable in the case of total or near total obstruction of distal runoff in the vessel (see FIG. 10A) where, for example, material M completely occludes the vessel distal to the material removal catheter. To establish a fluid recirculation circuit the flow rate of fluid out of vent holes 31 must exceed the volume of fluid entering into interior 68 of collection chamber 12 through lumen 4A (catheter 2A), through tube 7 (catheter 2B), through lumen 4C (catheter 2C), through hole 44 of cutting element 40, or through combinations of these structures (where used). When this flow condition occurs a negative pressure will be established in the interior 68 of collection chamber 12 and fluid will flow into collection chamber 12

through opening 6, thereby drawing particles P generated by the cutting element into the interior 68 of collection chamber 12 (FIGS. 10A and 10B).

[0061] In addition to use in blood vessels the invention is envisioned to be useful for removal of blockages in other blood flow lumens such as natural or artificial grafts, stent-grafts, anastomotic sites, fistulae, or other blood flow lumens.

[0062] The above description and the drawings are provided for the purpose of describing embodiments of the invention and are not intended to limit the scope of the invention in any way. It will be apparent to those skilled in the art that various modifications and variations can be made without departing from the spirit or scope of the invention. Thus, it is intended that the present invention cover the modifications and variations of this invention provided they come within the scope of the appended claims and their equivalents. Further, while choices for materials and configurations may have been described above with respect to certain embodiments, one of ordinary skill in the art will understand that the materials and configurations described are applicable across the embodiments.

What is claimed is:

1. An atherectomy catheter, comprising:
  - a body having an opening;
  - a rotatable shaft coupled to the body;
  - a tissue collection chamber coupled to the body and positioned distal to the cutting element;
  - a cutting element coupled to the rotatable shaft, the cutting element having a cutting edge; and
  - a lumen configured to direct fluid into the tissue collection chamber.
2. The catheter of claim 1, wherein the lumen directs fluid in a distal direction into the tissue collection chamber.
3. The catheter of claim 1, wherein the cutting element has a cup-shaped surface, the cup-shaped surface being configured to re-direct tissue cut by the cutting edge in a distal direction when the cup-shaped surface moves in the distal direction.
4. The catheter of claim 3, wherein the lumen has a distal opening on the cup-shaped surface of the cutting element.
5. The catheter of claim 4, wherein the lumen comprises a first lumen portion in the cutting element and a second lumen portion in the rotatable shaft.
6. The catheter of claim 4, wherein the distal opening is positioned at a longitudinal axis of the cutting element.
7. The catheter of claim 3, wherein the lumen has a distal opening and the distal opening is not positioned on the cup-shaped surface of the cutting element.
8. The catheter of claim 7, wherein the distal opening is positioned adjacent to the cup-shaped surface of the cutting element.
9. The catheter of claim 1, wherein a fluid source that supplies fluid to the lumen is attached to a proximal portion of the catheter.
10. The catheter of claim 9, wherein the fluid supplied by the fluid source is a saline solution.
11. The catheter of claim 9, wherein the fluid supplied by the fluid source comprises a radiopaque substance.
12. The catheter of claim 3, wherein a proximal opening of the lumen is positioned at a distal portion of the catheter but proximal of the cup-shaped surface of the cutting element.
13. The catheter of claim 12, wherein the proximal opening is positioned on the rotatable shaft.

14. The catheter of claim 13, wherein the rotatable shaft comprises two or more proximal openings of the lumen.

15. The catheter of claim 13, wherein the rotatable shaft comprises an impeller proximal of the proximal opening, the impeller forcing fluid into the proximal opening when the rotatable shaft is rotated.

16. The catheter of claim 15, wherein the impeller has 1 to 10 turns.

17. The catheter of claim 12, wherein the lumen has a distal opening on the cup-shaped surface of the cutting element.

18. The catheter of claim 17, wherein the distal opening is positioned at a longitudinal axis of the cutting element.

19. The catheter of claim 1, wherein a proximal opening of the lumen is positioned on the cutting element.

20. The catheter of claim 19, wherein the proximal opening is positioned at an outer edge of the cutting element.

21. The catheter of claim 20, wherein the cutting element has a cup-shaped surface, the cup-shaped surface being configured to re-direct tissue cut by the cutting edge in a distal direction when the cup-shaped surface moves in the distal direction, and the lumen has a distal opening on the cup-shaped surface of the cutting element.

22. The catheter of claim 21, wherein the distal opening is positioned at a longitudinal axis of the cutting element.

23. The catheter of claim 1, wherein the tissue collection chamber comprises vent holes.

24. The catheter of claim 23, wherein the tissue collection chamber comprises 10 to 200 vent holes.

25. The catheter of claim 23, wherein the vent holes have a diameter of from 25 to 200 microns.

26. The catheter of claim 1, wherein the cutting element is movable between a stored position and a cutting position relative to the opening.

27. An atherectomy catheter, comprising:

a body having an opening;

a rotatable shaft coupled to the body;

a tissue collection chamber coupled to the body and positioned distal to the cutting element;

a cutting element coupled to the rotatable shaft, the cutting element having a cutting edge; and

a part for propelling fluid distally in the tissue collection chamber, the part being selected from the group consisting of: (i) a drive shaft having a proximal end and a distal portion, the proximal end being attached to the cutting element and a propeller being attached to the distal portion; and (ii) a paddle attached to the cutting element.

28. The catheter of claim 27, wherein the cutting element has a cup-shaped surface, the cup-shaped surface being configured to re-direct tissue cut by the cutting edge in a distal direction when the cup-shaped surface moves in the distal direction.

29. The catheter of claim 28, wherein the part for propelling fluid distally in the tissue collection chamber is selected from the group consisting of: (i) a drive shaft having a proximal end and a distal portion, the proximal end being attached to the cup-shaped surface of the cutting element and a propeller being attached to the distal portion; and (ii) a paddle attached to the cup-shaped surface of the cutting element.

30. The catheter of claim 27, wherein the part for propelling fluid distally in the tissue collection chamber is a drive shaft having a proximal end and a distal portion, the proximal end being attached to the cutting element and a propeller being attached to the distal portion.

31. The catheter of claim 30, wherein the propeller is located distally of the opening and proximally of the distal end of the collection chamber.

32. The catheter of claim 31, wherein the propeller is located immediately distally of the opening.

33. The catheter of claim 31, wherein the propeller is located in the distal half of the collection chamber.

34. The catheter of claim 30, wherein the proximal end of the drive shaft is attached to a cup-shaped surface of the cutting element, the cup-shaped surface being configured to re-direct tissue cut by the cutting edge in a distal direction when the cup-shaped surface moves in the distal direction.

35. The catheter of claim 27, wherein the part for propelling fluid distally in the tissue collection chamber is a paddle attached to the cutting element.

36. The catheter of claim 35, wherein the paddle is a wire that is twisted in a helical configuration.

37. The catheter of claim 36, wherein the wire has a rectangular cross section.

38. The catheter of claim 36, wherein the wire has a thickness from 0.002 to 0.020 inch (0.0051 to 0.051 cm).

39. The catheter of claim 36, wherein the wire width is from 0.010 to 0.075 inch (0.025 to 0.19 cm).

40. The catheter of claim 36, wherein the paddle has a wire width that is from 20 to 95 percent of an inside diameter of the collection chamber.

41. The catheter of claim 35, wherein the paddle has a longitudinal length that is at least 50 percent of the longitudinal length of the collection chamber.

42. The catheter of claim 35, wherein the paddle has a longitudinal length that is at least 70 percent of the longitudinal length of the collection chamber.

43. The catheter of claim 27, wherein the tissue collection chamber comprises vent holes.

44. The catheter of claim 43, wherein the tissue collection chamber comprises 10 to 200 vent holes.

45. The catheter of claim 43, wherein the vent holes have a diameter of from 25 to 200 microns.

46. The catheter of claim 35, wherein the paddle is attached to a cup-shaped surface of the cutting element, the cup-shaped surface being configured to re-direct tissue cut by the cutting edge in a distal direction when the cup-shaped surface moves in the distal direction.

47. The catheter of claim 27, wherein the collection chamber comprises a portion at a distal end that can be opened to remove cut material and particles.

48. The catheter of claim 27, wherein the cutting element is movable between a stored position and a cutting position relative to the opening.

49. A method of recirculating fluid in an atherectomy catheter comprising:

providing an atherectomy catheter, the atherectomy catheter comprising:

a body having an opening;

a rotatable shaft coupled to the body;

a tissue collection chamber coupled to the body and positioned distal to the cutting element, the tissue collection chamber having vent holes;

a cutting element coupled to the rotatable shaft, the cutting element having a cutting edge; and

moving fluid out of the tissue collection chamber through the vent holes such that a negative pressure is created inside the tissue collection chamber and this negative

pressure causing fluid to enter the tissue collection chamber through the opening of the body of the catheter.

**50.** The method of claim **49**, wherein the catheter comprises a lumen configured to direct fluid into the tissue collection chamber.

**51.** The method of claim **49**, wherein the catheter comprises a part for propelling fluid distally in the tissue collection chamber, the part being selected from the group consisting of: (i) a drive shaft having a proximal end and a distal portion, the proximal end being attached to the cutting element and a propeller being attached to the distal portion; and (ii) a paddle attached to the cutting element.

**52.** A method of removing material from a body lumen, the method comprising:

providing an atherectomy catheter, the atherectomy catheter comprising:  
 a body having an opening;  
 a rotatable shaft coupled to the body;  
 a tissue collection chamber coupled to the body and positioned distal to the cutting element;  
 a cutting element coupled to the rotatable shaft, the cutting element having a cutting edge; and  
 a lumen configured to direct fluid into the tissue collection chamber;

placing the catheter in the body lumen; and  
 moving the catheter in the body lumen to contact the cutting element with the material in the body lumen.

**53.** The method of claim **52**, wherein the catheter is moved in a distal direction to contact the cutting edge with the material in the body lumen.

**54.** The method of claim **52**, wherein the catheter is placed in the body lumen with the cutting element in the stored position and the catheter is moved to contact the material with the cutting element in a cutting position.

**55.** The method of claim **52**, wherein the body lumen is a blood vessel.

**56.** A method of removing material from a body lumen, the method comprising:

providing an atherectomy catheter, the atherectomy catheter comprising:  
 a body having an opening;  
 a rotatable shaft coupled to the body;  
 a tissue collection chamber coupled to the body and positioned distal to the cutting element;  
 a cutting element coupled to the rotatable shaft, the cutting element having a cutting edge; and  
 a part for propelling fluid distally in the tissue collection chamber, the part being selected from the group consisting of: (i) a drive shaft having a proximal end and a distal portion, the proximal end being attached to the cutting element and a propeller being attached to the distal portion; and (ii) a paddle attached to the cutting element;

placing the catheter in the body lumen; and  
 moving the catheter in the body lumen to contact the cutting element with the material in the body lumen.

**57.** The method of claim **56**, wherein the catheter is moved in a distal direction to contact the cutting edge with the material in the body lumen.

**58.** The method of claim **56**, wherein the catheter is placed in the body lumen with the cutting element in the stored position and the catheter is moved to contact the material with the cutting element in a cutting position.

**59.** The method of claim **56**, wherein the body lumen is a blood vessel.

\* \* \* \* \*