

L. E. DIETZ.  
 OPERATING MECHANISM.  
 APPLICATION FILED APR. 29, 1910.

999,758.

Patented Aug. 8, 1911.

2 SHEETS—SHEET 1.

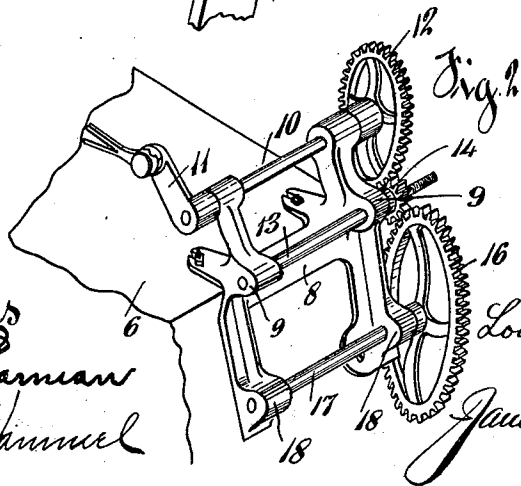
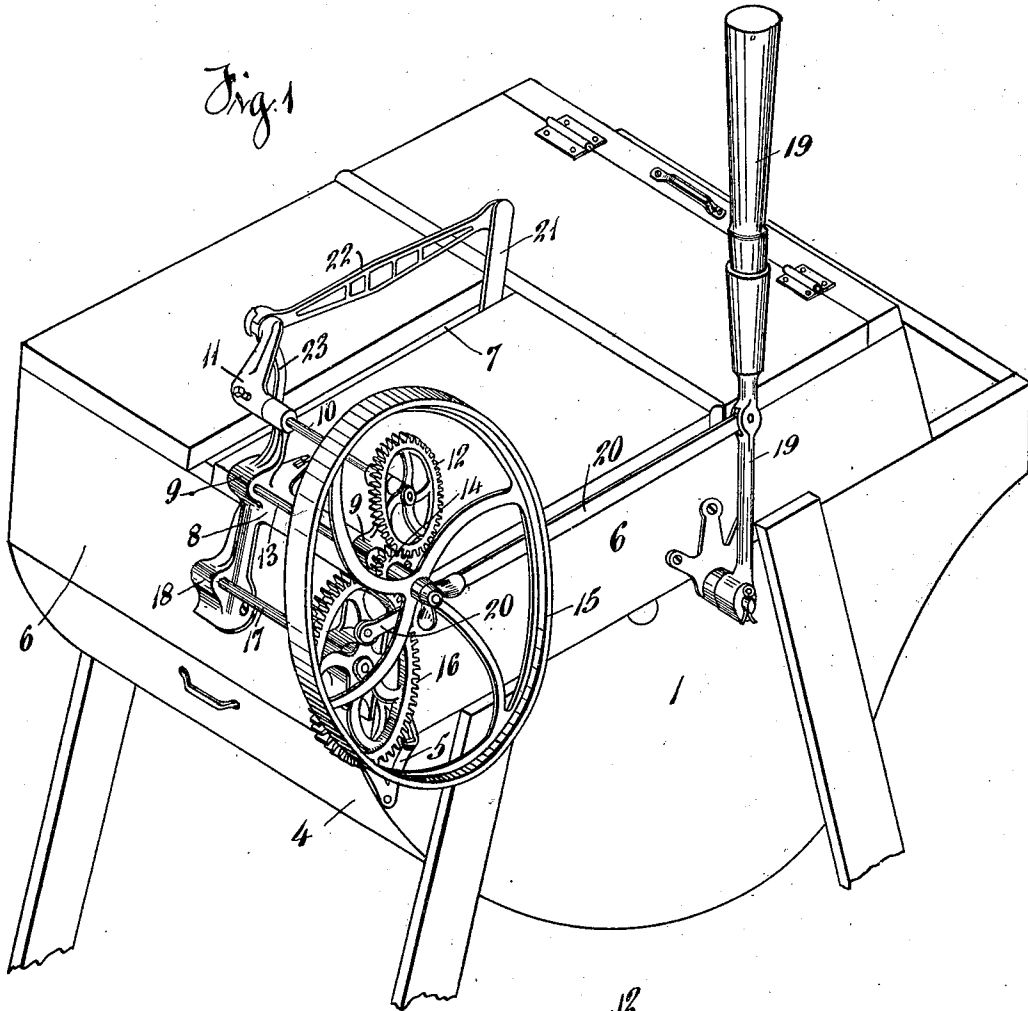

Witnesses  
 Carroll G. Haman  
 Florence Hamman

Inventor  
 Louis E. Dietz

James A. Raussey

Attorney

L. E. DIETZ.  
OPERATING MECHANISM.  
APPLICATION FILED APR. 29, 1910.

999,758.

Patented Aug. 8, 1911.

2 SHEETS—SHEET 2.

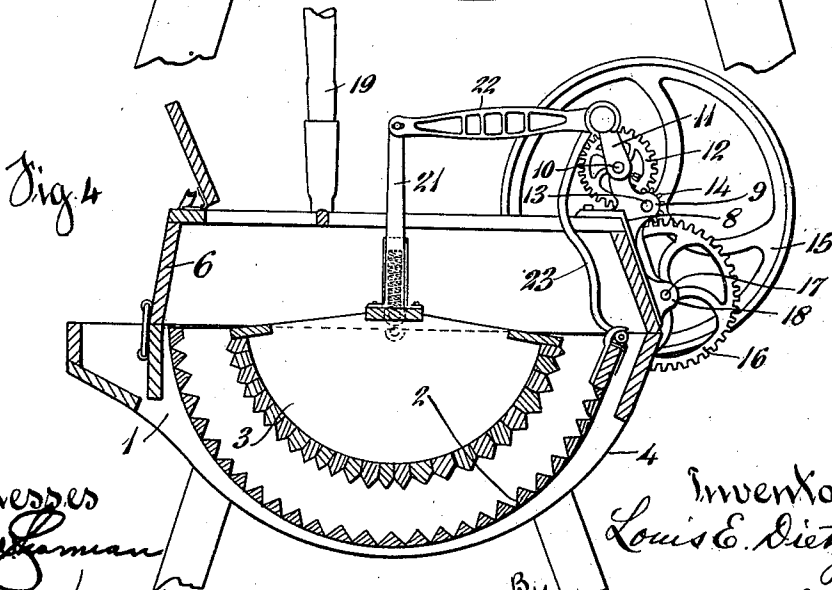
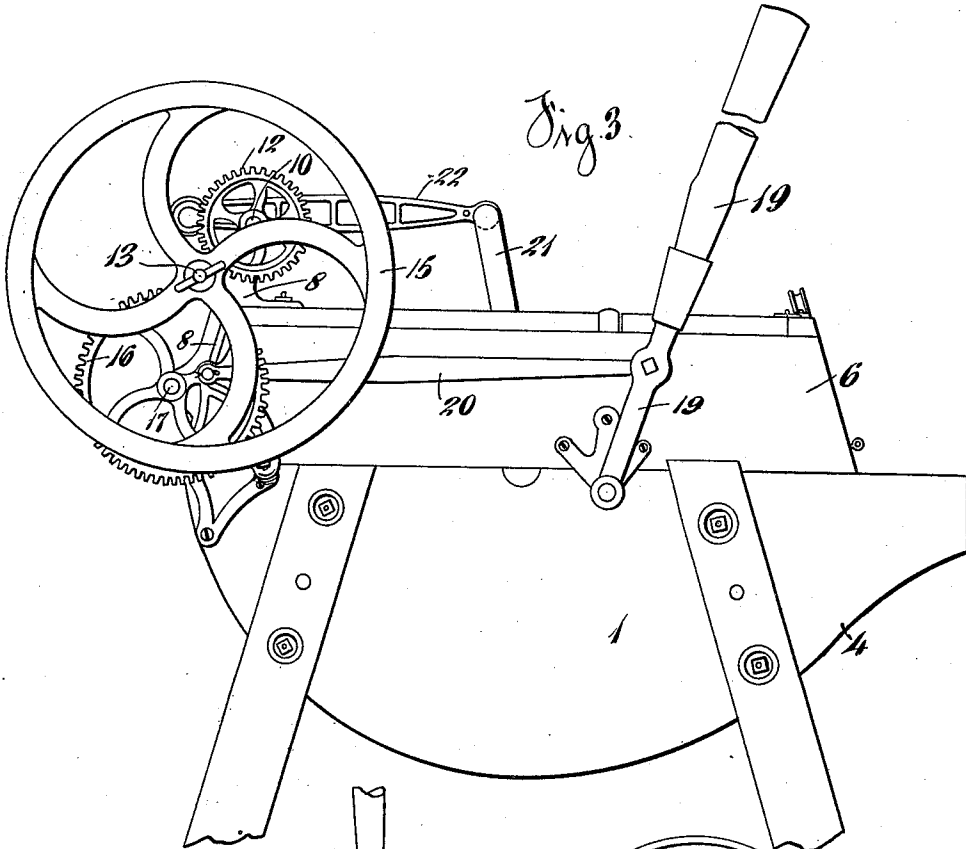

Witnesses  
Clarence Gaman  
Florence Hammel

Inventor  
Louis E. Dietz  
By  
James A. Ramsey  
Attorney

# UNITED STATES PATENT OFFICE.

LOUIS E. DIETZ, OF CINCINNATI, OHIO.

OPERATING MECHANISM.

999,758.

Specification of Letters Patent.

Patented Aug. 8, 1911.

Application filed April 29, 1910. Serial No. 558,470.

To all whom it may concern:

Be it known that I, LOUIS E. DIETZ, a citizen of the United States, residing at Cincinnati, in the county of Hamilton and State of Ohio, have invented certain new and useful Improvements in Operating Mechanism, of which the following is a specification.

My invention relates to operating mechanism, and is particularly adapted for use in operating washing machines.

The object of my invention is to provide simple, convenient efficient and durable mechanism for producing a high speed by the application of a minimum of power, and also to so construct and arrange said mechanism as to render it particularly applicable to the operation of a double reciprocating rubber type of washing machine.

My invention consists in providing operating mechanism comprising a crank shaft suitably journaled, a gear wheel on said shaft, a pinion shaft mounted parallel with said crank shaft, and having a pinion thereon engaging said gear wheel and also having a fly wheel rigidly secured thereon, a shaft mounted parallel with said pinion shaft and having rigidly secured thereon a gear adapted to mesh with said pinion, a handle pivotally mounted and a pitman connecting said gear with said handle.

My invention also consists in the parts and combination of parts and in the peculiar and particular construction, location and arrangement of parts with relation to the washing machine of the type herein illustrated as herein set forth and claimed.

In the accompanying drawings, which serve to illustrate the construction and operation of my invention: Figure 1 is an isometric view of a washing machine equipped with my invention. Fig. 2 is an isometric view from another position showing the application of my invention to the washing machine. Fig. 3 is a side elevation of a washing machine equipped with my invention. Fig. 4 is a central vertical section from front to rear of the machine.

My invention, as illustrated, is mounted upon a reciprocating or double rubber type of washing machine 1 having pivotally mounted therein an oscillating clothes receptacle 2 and dasher 3 which are adapted to reciprocate simultaneously in opposite directions to rub clothing between them. Upon the body 4 of the machine is hinged

at 5 a lid 6 having an elongated slot 7. The clothes receptacle 2 is pivotally mounted in the body 4 and is preferably detachably connected thereto and to the operating mechanism. The dasher 3 is pivotally and slidably mounted in elongated bearings in the lid or cover 6 and is carried thereby, so that when the lid is open the dasher 3 is withdrawn from its position within the clothes receptacle to permit free access thereto.

Upon the hinged end of the lid 6 I rigidly secure a bracket 8 having supports 9 in which are mounted a horizontally disposed crank shaft 10 having a crank 11 on the inner end and a gear wheel 12 on the outer end. A pinion shaft 13 journaled parallel with the crank shaft 10, having a pinion 14 fixed thereon and engaging with the gear wheel 12 has a fly wheel 15 fixed upon its outer end to provide for increased momentum in the operation of the machine. A gear 16 in mesh with pinion 14 is fixed upon shaft 17 mounted in bearings 18 on the end of lid 6. A handle 19 is pivoted to one side of the lid near its front end and is connected to the gear 16 by a connecting rod 20. The dasher 3 is provided with an operating arm 21 extending up through slot 7 and is preferably detachably connected to crank 11 by pitman 22. A pitman 23 also pivotally connects the clothes receptacle (which is preferably provided with clothes rubbing surface upon its interior) with said crank so that when the crank is revolving continuously in one direction it will impart reciprocating motion to said clothes receptacle and dasher, causing them to reciprocate simultaneously in opposite directions and producing the desired rubbing and agitating effect upon the clothing which is placed within said clothes receptacle and beneath said dasher or rubber. When it is desired to operate the machine simply open the lid, place the clothing therein, close and secure the lid and move the handle 19 back and forth. This will cause the gear, pinion and gear wheel to each move continuously in one direction and will impart movement to the fly wheel which will produce the necessary momentum to give the required speed to the machine with a minimum of exertion or application of power on the part of the operator.

It will be seen that by rigidly mounting the gear wheel, pinion, fly wheel and gear upon long shafts, I am enabled to secure

substantial bearings and avoid undue wearing or friction of the parts. By this means also the several parts are all mounted upon one substantial bracket and securely held in fixed relation with each other, thereby preventing shifting or separation of the parts. The gear 16 being larger than the pinion 14 which it actuates rotates the fly wheel 15 fixed upon the pinion shaft at a much greater speed and the size of the gear wheel determines the speed of the clothes rubbing devices. The gear wheel, pinion and gear being in direct line with each other and being of the comparative sizes illustrated, produce the required speed and momentum of power and with a minimum of wear upon the parts. The entire mechanism being mounted upon the lid permits ready and easy access to the interior of the machine.

The double oscillating or reciprocating rubber type of washing machine herein illustrated has heretofore been operated by means of a hand wheel mounted upon the end of the crank, as shown in Patent No. 569,619 issued to Conrad Dietz, October 20, 1896, and Patent No. 581,509 issued to him April 27, 1897, without the use of any high speed operating mechanism. With my invention I dispense with the use of said hand wheel and substitute therefor suitable means for producing a high speed including such modifications and variations in the construction, combination and arrangement of the operating mechanism herein illustrated as would be applicable in accomplishing the desired result as set forth and claimed.

I claim:

1. In operating mechanism of the character described, a bracket, a crank shaft thereon, a gear wheel on said crank shaft, a pinion shaft mounted parallel with said crank shaft, a pinion fixed thereon and meshing with said gear wheel, a fly wheel fixed upon said pinion shaft, a shaft parallel with said pinion shaft, a gear fixed thereon and meshing with said pinion, and means to operate said gear.

2. In operating mechanism of the character described, a bracket, a crank shaft thereon, a gear wheel on said crank shaft, a pinion shaft mounted parallel with said crank shaft, a pinion fixed thereon near its end and meshing with said gear wheel, a shaft mounted parallel with said pinion shaft and below the horizontal plane thereof, a gear fixed thereon and meshing with said pinion, and means to operate said gear.

3. Operating mechanism comprising a crank shaft suitably mounted, a gear wheel thereon, a shaft, a pinion thereon adapted to engage said gear wheel, and a fly wheel adapted to give momentum thereto, both mounted upon the same shaft, and means to operate said pinion, substantially as set forth.

4. Operating mechanism comprising a crank shaft suitably mounted, a gear wheel mounted upon said crank shaft, a shaft, a pinion thereon adapted to actuate said gear wheel, and a fly wheel adapted to give momentum to the operating mechanism, both fixed upon a single shaft, a gear mounted to actuate said pinion, and means for actuating said gear, substantially as set forth.

5. Operating mechanism comprising a bracket suitably mounted upon a machine and having bearings therein, a crank shaft journaled in said bracket above said machine, a crank on the inner end of said crank shaft, a gear wheel on the outer end thereof, a pinion shaft journaled in bearings in said bracket, a pinion fixed thereon and meshing with said gear wheel, a shaft journaled in bearings on said bracket at the end of said machine, a gear fixed on the end thereof and at the side of the machine and meshing with said pinion to actuate the same, a handle pivotally mounted upon the side of said machine, a connecting rod operatively connecting said handle and gear, and a fly wheel fixed upon the end of said pinion shaft to give momentum to said operating mechanism, substantially as and for the purposes set forth.

6. Operating mechanism comprising a bracket fixed upon the top and end of a machine, a crank shaft mounted in bearings in said bracket above said machine, a crank upon the inner end of said shaft, a gear wheel at the outer end thereof, a pinion shaft journaled in bearings in said bracket above said machine and having a pinion fixed thereon engaging said gear wheel, a shaft journaled in bearings in said bracket at the end of said machine, a gear fixed thereon at the end of said shaft and at the side of said machine, said gear engaging with said pinion to actuate the same, a handle pivotally mounted upon said machine, a connecting rod pivoted to said handle at one end and to said gear near its periphery at the other end, and a crank wheel fixed upon said pinion-shaft and disposed vertically at the side of said machine to give momentum to the operating mechanism, substantially as and for the purposes set forth.

7. Operating mechanism comprising a bracket suitably mounted upon the end of a machine and having supports and bearings, a crank shaft journaled in said supports, a crank upon one end of said shaft, a gear wheel upon the other end thereof, a pinion shaft journaled in bearings in said supports, a pinion fixed upon said pinion shaft and meshing with said gear wheel to actuate the same, a shaft journaled in bearings in said bracket, a gear fixed thereon and meshing with said pinion to actuate the same, a handle pivotally mounted upon said

machine at one side near its front end, a  
connecting rod pivoted to said handle and  
to said gear wheel to actuate the latter, an  
oscillating member pivotally mounted in the  
5 body of said machine, a pitman pivotally  
connecting said oscillating member and  
crank, a swinging member pivotally mounted  
in said machine, an arm on said swinging  
member projecting through a slot in said  
10 machine, a pitman connecting said arm and  
said crank whereby when said handle is  
moved back and forth said operating mecha-

nism will impart a reciprocating motion to  
said oscillating and swinging members, si-  
multaneously in opposite directions, and a fly 15  
wheel fixed upon said pinion shaft adapted  
to give the required momentum to said oper-  
ating mechanism, substantially as set forth  
and for the purposes specified.

LOUIS E. DIETZ.

Witnesses:

JAMES N. RAMSEY,  
FLORENCE HAMMEL.

---

Copies of this patent may be obtained for five cents each, by addressing the "Commissioner of Patents,  
Washington, D. C."

---