



- (51) International Patent Classification:
A61B 17/12 (2006.01)
- (21) International Application Number:
PCT/US2013/069955
- (22) International Filing Date:
13 November 2013 (13.11.2013)
- (25) Filing Language: English
- (26) Publication Language: English
- (30) Priority Data:
61/725,768 13 November 2012 (13.11.2012) US
- (71) Applicant: COVIDIEN LP [US/US]; 15 Hampshire Street, Mansfield, MA 02048 (US).
- (72) Inventors: DIVINO, Vincent; 24436 Muela, Mission Viejo, CA 92692 (US). BARDSLEY, Earl Frederick; 6349 Camino Marinero, San Clemente, CA 92673 (US). RHEE, Richard; 553 S. Sunnyhill Way, Anaheim, CA 92808 (US). KADAM, Madhur Arunrao; 26136 Emyvale Ct., Lake Forest, CA 92630 (US). KULAK, Julie; 31872 Joshua Drive, 7L, Trabuco Canyon, CA 92679 (US).
- (74) Agents: O'BRIEN, Elizabeth A. et al.; Covidien LP, 15 Hampshire Street, Mansfield, MA 02048 (US).

(81) Designated States (unless otherwise indicated, for every kind of national protection available): AE, AG, AL, AM, AO, AT, AU, AZ, BA, BB, BG, BH, BN, BR, BW, BY, BZ, CA, CH, CL, CN, CO, CR, CU, CZ, DE, DK, DM, DO, DZ, EC, EE, EG, ES, FI, GB, GD, GE, GH, GM, GT, HN, HR, HU, ID, IL, IN, IR, IS, JP, KE, KG, KN, KP, KR, KZ, LA, LC, LK, LR, LS, LT, LU, LY, MA, MD, ME, MG, MK, MN, MW, MX, MY, MZ, NA, NG, NI, NO, NZ, OM, PA, PE, PG, PH, PL, PT, QA, RO, RS, RU, RW, SA, SC, SD, SE, SG, SK, SL, SM, ST, SV, SY, TH, TJ, TM, TN, TR, TT, TZ, UA, UG, US, UZ, VC, VN, ZA, ZM, ZW.

(84) Designated States (unless otherwise indicated, for every kind of regional protection available): ARIPO (BW, GH, GM, KE, LR, LS, MW, MZ, NA, RW, SD, SL, SZ, TZ, UG, ZM, ZW), Eurasian (AM, AZ, BY, KG, KZ, RU, TJ, TM), European (AL, AT, BE, BG, CH, CY, CZ, DE, DK, EE, ES, FI, FR, GB, GR, HR, HU, IE, IS, IT, LT, LU, LV, MC, MK, MT, NL, NO, PL, PT, RO, RS, SE, SI, SK, SM, TR), OAPI (BF, BJ, CF, CG, CI, CM, GA, GN, GQ, GW, KM, ML, MR, NE, SN, TD, TG).

Published:

— without international search report and to be republished upon receipt of that report (Rule 48.2(g))

(54) Title: OCCLUSIVE DEVICES

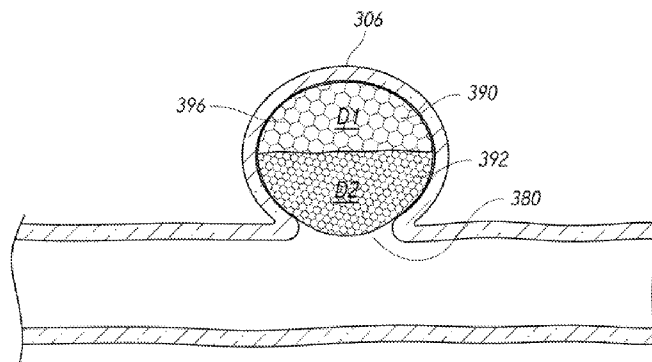
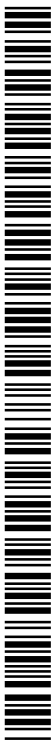

FIG. 27

(57) Abstract: A system for treatment of an aneurysm includes an intrasaccular device that can be delivered using a catheter. The device can include at least one expandable structure adapted to transition from a compressed configuration to an expanded configuration when released into the aneurysm. The expandable structure can have a specific shape or porosity. Multiple expandable structures can also be used, in which case each of the expandable structures can have a unique shape or porosity profile. The morphology of the aneurysm and orientation of any connecting arteries can determine the type, size, shape, number, and porosity profile of the expandable structure used in treating the aneurysm.



OCCLUSIVE DEVICES

CROSS-REFERENCE TO RELATED APPLICATIONS

[0001] This application claims the benefit of U.S. Provisional Application No. 61/725,768, filed November 13, 2012, the entirety of which is incorporated herein by reference.

BACKGROUND

Field of the Inventions

[0002] The present disclosure generally relates to a system and method for delivering and deploying a medical device within a vessel, more particularly, it relates to a system and method for delivering and deploying an endoluminal therapeutic device within the vasculature of a patient to embolize and occlude aneurysms, particularly, cerebral aneurysms.

Description of the Related Art

[0003] Walls of the vasculature, particularly arterial walls, may develop areas of pathological dilatation called aneurysms. As is well known, aneurysms have thin, weak walls that are prone to rupturing. Aneurysms can be the result of the vessel wall being weakened by disease, injury or a congenital abnormality. Aneurysms could be found in different parts of the body with the most common being abdominal aortic aneurysms and brain or cerebral aneurysms in the neurovasculature. When the weakened wall of an aneurysm ruptures, it can result in death, especially if it is a cerebral aneurysm that ruptures.

[0004] Aneurysms are generally treated by excluding the weakened part of the vessel from the arterial circulation. For treating a cerebral aneurysm, such reinforcement is done in many ways including: (i) surgical clipping, where a metal clip is secured around the base of the aneurysm; (ii) packing the aneurysm with small, flexible wire coils (micro-coils); (iii) using embolic materials to “fill” or “pack” an aneurysm; (iv) using detachable balloons or coils to occlude the parent vessel that supplies the aneurysm; and (v) intravascular stenting.

[0005] In conventional methods of introducing a compressed stent into a vessel and positioning it within in an area of stenosis or an aneurysm, a guiding catheter having a distal tip is percutaneously introduced into the vascular system of a patient. The guiding catheter is advanced within the vessel until its distal tip is proximate the stenosis or aneurysm. A guidewire

positioned within an inner lumen of a second, inner catheter and the inner catheter are advanced through the distal end of the guiding catheter. The guidewire is then advanced out of the distal end of the guiding catheter into the vessel until the distal portion of the guidewire carrying the compressed stent is positioned at the point of the lesion within the vessel. Once the compressed stent is located at the lesion, the stent may be released and expanded so that it supports the vessel.

SUMMARY

[0006] Additional features and advantages of the subject technology will be set forth in the description below, and in part will be apparent from the description, or may be learned by practice of the subject technology. The advantages of the subject technology will be realized and attained by the structure particularly pointed out in the written description and embodiments hereof as well as the appended drawings.

[0007] Systems and procedures for treating aneurysms can include an intrasaccular device having one or more expandable components that can be inserted into an aneurysm to facilitate a thrombotic, healing effect. The components can have a specific characteristics, including porosity, composition, material, shape, size, interconnectedness, inter-engagement, coating, etc. These characteristics can be selected in order to achieve a desired treatment or placement of the intrasaccular device.

[0008] The intrasaccular device can comprise a single component having two or more sections that have an average porosity that is different from each other. In some embodiments, the intrasaccular device can comprise multiple components that each have an average porosity. In either embodiment, the intrasaccular device can be arranged within an aneurysm according to a desired porosity profile. The intrasaccular device can be repositioned as necessary within the aneurysm during expansion.

[0009] The intrasaccular device can optionally comprise one or more components having a desired shape, which can allow a clinician to implant an intrasaccular device tailored to the aneurysm. A plurality of individual, independent components can operate collectively to form a composite unit having one or more desired characteristics. Such components can have an interlocking structure, which can include a framing component, according to some embodiments.

[0010] The intrasaccular device, when used with a framing component, can enable expandable components to be securely retained within an aneurysm. A framing component can comprise a foam or braided structure. Further, one or more expandable components can be inserted into a cavity of or formed by the framing component.

[0011] Additionally, the intrasaccular device can also be configured to provide a plurality of interconnected expandable components, extending in linear, planar, or three-dimensional arrays or matrices. These arrays or matrices can be deployed in whole or in part into a target aneurysm, allowing a clinician to select portions of the array or matrix for implantation.

[0012] The subject technology is illustrated, for example, according to various aspects described below. Various examples of aspects of the subject technology are described as numbered embodiments (1, 2, 3, etc.) for convenience. These are provided as examples and do not limit the subject technology. It is noted that any of the dependent embodiments may be combined in any combination with each other or one or more other independent embodiments, to form an independent embodiment. The other embodiments can be presented in a similar manner. The following is a non-limiting summary of some embodiments presented herein:

[0013] Embodiment 1. A device for treatment of an aneurysm, comprising a foam component having first and second sections, the first section having an average porosity different from an average porosity of the second section, the component being expandable from a compressed configuration to an expanded configuration when released into an aneurysm from a catheter.

[0014] Embodiment 2. The device of Embodiment 1, wherein the component is self-expanding to assume the expanded configuration thereof.

[0015] Embodiment 3. The device of Embodiment 1, wherein the component is adapted to expand upon exposure to a thermal agent.

[0016] Embodiment 4. The device of Embodiment 1, wherein the component is adapted to expand upon exposure to a chemical agent.

[0017] Embodiment 5. The device of Embodiment 1, wherein the first section comprises a first material and the second section comprises a second material different from the first material, the first and second sections being coupled to each other.

[0018] Embodiment 6. The device of Embodiment 5, wherein the first section is coupled to the second section by chemical bonding, by thermal bonding, or by mechanical crimping.

[0019] Embodiment 7. The device of Embodiment 1, wherein the component further comprises a third section coupled to the second section, the third section having an average porosity different from the porosity of the second section.

[0020] Embodiment 8. The device of Embodiment 7, wherein the third material is different from the first material.

[0021] Embodiment 9. The device of Embodiment 7, wherein the second section is coupled to the third section using an adhesive.

[0022] Embodiment 10. The device of Embodiment 7, wherein the second section comprises a second material and the third section comprises a third material different from the second material.

[0023] Embodiment 11. The device of Embodiment 7, wherein the third section porosity is different from the first section porosity.

[0024] Embodiment 12. The device of Embodiment 11, wherein the first section comprises an average porosity of between about 1 μm and about 150 μm , and the third section comprises an average porosity of between 150 μm and about 300 μm .

[0025] Embodiment 13. The device of Embodiment 1, further comprising a transition zone between the first and second sections, the transition zone having an average porosity intermediate the porosities of the first and second sections.

[0026] Embodiment 14. The device of Embodiment 13, wherein the transition zone porosity varies spatially from about that of the first section to about that of the second section.

[0027] Embodiment 15. The device of Embodiment 13, wherein the porosity in the first and second sections each spatially varies progressively from an end of the first section to an opposite end of the second section.

[0028] Embodiment 16. The device of Embodiment 13, wherein the transition zone porosity decreases from the porosity of the first section to the porosity of the second section.

[0029] Embodiment 17. The device of Embodiment 1, wherein in the expanded configuration, the component comprises a substantially spherical shape that is divided crosswise into the first and second sections.

[0030] Embodiment 18. The device of Embodiment 17, wherein the first and second sections correspond to first and second hemispheres of the substantially spherical shape.

[0031] Embodiment 19. The device of Embodiment 17, further comprising a third section coupled to the second section, the first, second, and third sections collectively forming the substantially spherical shape.

[0032] Embodiment 20. The device of Embodiment 1, wherein the component further comprises a bioactive coating.

[0033] Embodiment 21. The device of Embodiment 20, wherein the bioactive coating comprises a thrombogenic drug.

[0034] Embodiment 22. The device of Embodiment 1, wherein the component further comprises an expansion-limiting coating configured to control an expansion rate of the component.

[0035] Embodiment 23. The device of Embodiment 1, wherein the first section comprises an average porosity of between about 1 μm and about 100 μm , and the second section comprises an average porosity of between about 100 μm and about 200 μm .

[0036] Embodiment 24. The device of Embodiment 1, wherein a shape of the component is selected from the group consisting of cylinders, hemispheres, polyhedrons, prolate spheroids, oblate spheroids, plates, bowls, hollow structures, clover shapes, non-spherical surface of revolution, and combinations thereof.

[0037] Embodiment 25. The device of Embodiment 24, further comprising a second foam component having a shape selected from the group consisting of spheres, cylinders, hemispheres, polyhedrons, prolate spheroids, oblate spheroids, plates, bowls, hollow structures, clover shapes, non-spherical surface of revolution, and combinations thereof.

[0038] Embodiment 26. The device of Embodiment 25, wherein the foam component and the second foam component are different sizes from each other.

[0039] Embodiment 27. The device of Embodiment 25, wherein the foam component and the second foam component are different shapes from each other.

[0040] Embodiment 28. The device of Embodiment 25, wherein the foam component and the second foam component have mating structures configured to abut each other in a complementary configuration and restrict at least degrees of freedom of motion of each of the foam component and the second foam component.

[0041] Embodiment 29. The device of Embodiment 25, further comprising a plurality of additional foam components having substantially spherical shapes.

[0042] Embodiment 30. A system for treatment of an aneurysm, comprising a plurality of foam components being expandable from a compressed configuration to an expanded configuration when released into an aneurysm from a catheter, each of the plurality of components having an average porosity that is different from an average porosity of another of the plurality of components, the plurality of components being positionable within the aneurysm to form a composite foam component having a composite porosity configured to provide a therapeutic effect.

[0043] Embodiment 31. The system of Embodiment 30, wherein each of a first group of the plurality of components comprises a first average porosity, and each of a second group of the plurality of components comprises a second average porosity different from the first average porosity.

[0044] Embodiment 32. The system of Embodiment 31, wherein the first average porosity is between about 1 μm and about 100 μm , and the second average porosity is between about 100 μm and about 200 μm .

[0045] Embodiment 33. The system of Embodiment 30, wherein a shape of at least one of the plurality of components is substantially spherical.

[0046] Embodiment 34. The system of Embodiment 30, wherein a shape of at least one of the plurality of components is selected from the group consisting of spheres, cylinders, hemispheres, polyhedrons, prolate spheroids, oblate spheroids, plates, bowls, hollow structures, clover shapes, non-spherical surface of revolution, and combinations thereof.

[0047] Embodiment 35. The system of Embodiment 30, wherein each of the plurality of components is interconnected to another of the plurality of components via a filament.

[0048] Embodiment 36. The system of Embodiment 35, wherein each of the plurality of components is interconnected to at least two others of the plurality of components.

[0049] Embodiment 37. The system of Embodiment 30, wherein the plurality of components is self-expanding to assume the expanded configuration thereof.

[0050] Embodiment 38. The system of Embodiment 30, wherein the plurality of components is adapted to expand upon exposure to a thermal agent.

[0051] Embodiment 39. The system of Embodiment 30, wherein the plurality of components is adapted to expand upon exposure to a chemical agent.

[0052] Embodiment 40. The system of Embodiment 30, wherein at least one of the plurality of components comprises a bioactive coating.

[0053] Embodiment 41. The system of Embodiment 30, wherein at least one of the plurality of components comprises a thrombogenic drug.

[0054] Embodiment 42. The system of Embodiment 30, wherein at least one of the plurality of components comprises an expansion-limiting coating configured to control an expansion rate of the component.

[0055] Embodiment 43. The system of Embodiment 30, wherein each of the plurality of components is different sizes from another of the plurality.

[0056] Embodiment 44. The system of Embodiment 30, wherein each of the plurality of components is different shapes from another of the plurality.

[0057] Embodiment 45. The system of Embodiment 30, wherein a first of the plurality of components and a second of the plurality of components have mating structures configured to abut each other in a complementary configuration and restrict at least degrees of freedom of motion of each of the first and second of the plurality of components.

[0058] Embodiment 46. A device for treatment of an aneurysm, comprising a foam component having a region of variable average porosity and a radiopaque marker, the marker being visible under imaging and positionable relative to the region so as to facilitate identification and orientation of the component when implanted into the aneurysm from a catheter, the component being expandable from a compressed configuration to an expanded configuration when released into the aneurysm.

[0059] Embodiment 47. The device of Embodiment 46, wherein the region comprises a first section and a second section having an average porosity different from an average porosity of the first material.

[0060] Embodiment 48. The device of Embodiment 47, wherein the region further comprises a third section adjacent to the second section, the third section having an average porosity different from the porosity of the second section.

[0061] Embodiment 49. The device of Embodiment 48, wherein the second section is coupled to the third section by chemical bonding, by thermal bonding, or by mechanical crimping.

[0062] Embodiment 50. The device of Embodiment 48, wherein the third section porosity is different from the first section porosity.

[0063] Embodiment 51. The device of Embodiment 46, wherein the region comprises a first material and a second material different from the first material, the first and second materials being coupled to each other.

[0064] Embodiment 52. The device of Embodiment 51, wherein the region further comprises a third material different from the first material.

[0065] Embodiment 53. The device of Embodiment 46, wherein the marker comprises a material blended into the component such that the component is visible under imaging.

[0066] Embodiment 54. The device of Embodiment 53, wherein the marker comprises bisumuth or tantalum blended with a foam material to form the component.

[0067] Embodiment 55. The device of Embodiment 46, wherein the marker is coupled to an exterior of the component.

[0068] Embodiment 56. The device of Embodiment 55, wherein the marker comprises a coating or a material that is bonded or mechanically coupled to the component.

[0069] Embodiment 57. The device of Embodiment 46, wherein a shape of the component is selected from the group consisting of cylinders, hemispheres, polyhedrons, prolate spheroids, oblate spheroids, plates, bowls, hollow structures, clover shapes, non-spherical surface of revolution, and combinations thereof.

[0070] Embodiment 58. The device of Embodiment 57, further comprising a second foam component having a shape selected from the group consisting of spheres, cylinders, hemispheres, polyhedrons, prolate spheroids, oblate spheroids, plates, bowls, hollow structures, clover shapes, non-spherical surface of revolution, and combinations thereof.

[0071] Embodiment 59. The device of Embodiment 58, wherein the foam component and the second foam component are different sizes from each other.

[0072] Embodiment 60. The device of Embodiment 58, wherein the foam component and the second foam component are different shapes from each other.

[0073] Embodiment 61. The device of Embodiment 58, wherein the foam component and the second foam component have mating structures configured to abut each other in a complementary configuration and restrict at least degrees of freedom of motion of each of the foam component and the second foam component.

[0074] Embodiment 62. The device of Embodiment 58, further comprising a plurality of additional foam components having substantially spherical shapes.

[0075] Embodiment 63. A method for treatment of an aneurysm, comprising: advancing a foam component through a catheter lumen, the component comprising a first section having a different average porosity than an average porosity of a second section; releasing the component into the aneurysm; allowing the component to expand from a compressed configuration to an expanded configuration within the aneurysm; and positioning the component within the aneurysm such that the first section is positioned away from the aneurysm neck and the second section is positioned adjacent to a neck of the aneurysm.

[0076] Embodiment 64. The method of Embodiment 63, wherein the positioning comprises rotating the component.

[0077] Embodiment 65. The method of Embodiment 63, wherein the positioning comprises maintaining a position of the component relative to the aneurysm neck during expansion to the expanded configuration.

[0078] Embodiment 66. The method of Embodiment 63, wherein the aneurysm is disposed adjacent at bifurcation of a parent vessel into two efferent vessels, and wherein the positioning further comprises positioning the second section adjacent to the bifurcation and permitting flow through the bifurcation and into at least one of the first or second efferent vessels.

[0079] Embodiment 67. The method of Embodiment 66, wherein the first section comprises an average porosity of between about 1 μm and about 150 μm .

[0080] Embodiment 68. The method of Embodiment 66, wherein the second section comprises an average porosity of between about 100 μm and about 200 μm .

[0081] Embodiment 69. The method of Embodiment 63, wherein the component further comprises a third section disposed between the first and second sections, the third section having an average porosity different than the porosity of the second section, wherein the positioning comprises positioning the component such that the first section is positioned at a

fundus of the aneurysm and the third section is positioned between the fundus and the aneurysm neck.

[0082] Embodiment 70. The method of Embodiment 63, wherein the positioning comprises aligning a radiopaque marker relative to the aneurysm to position the second section adjacent to the aneurysm neck.

[0083] Embodiment 71. The method of Embodiment 70, wherein the aligning comprises aligning the marker with a fundus of the aneurysm.

[0084] Embodiment 72. The method of Embodiment 63, further comprising injecting a liquid embolic material into the aneurysm after positioning the component.

[0085] Embodiment 73. The method of Embodiment 63, further comprising implanting a support structure into the aneurysm before releasing the component into the aneurysm, and wherein the releasing comprises releasing the component through a wall of the support structure into the aneurysm.

[0086] Embodiment 74. The method of Embodiment 73, wherein the support structure comprises a substantially enclosed interior cavity, and the releasing further comprises releasing the component into the interior cavity.

[0087] Embodiment 75. A system for treatment of an aneurysm, comprising: a first foam component being expandable from a compressed configuration to an expanded configuration when released into the aneurysm, the first component having a first shape when in the expanded configuration; and a second foam component, separate from and freely movable relative to the first component, being expandable from a compressed configuration to an expanded configuration when released into the aneurysm, the second component having a second shape when in the expanded configuration; wherein at least one of the first and second shapes is selected from the group consisting of cylinders, hemispheres, polyhedrons, prolate spheroids, oblate spheroids, plates, bowls, hollow structures, clover shapes, non-spherical surface of revolution, and combinations thereof.

[0088] Embodiment 76. The system of Embodiment 75, wherein the first and second shapes are different from each other.

[0089] Embodiment 77. The system of Embodiment 75, wherein the first and second components are different sizes from each other.

[0090] Embodiment 78. The system of Embodiment 75, further comprising a third foam component, the third component having a third shape different from the first shape.

[0091] Embodiment 79. The system of Embodiment 78, wherein the third shape is substantially spherical.

[0092] Embodiment 80. The system of Embodiment 78, wherein the first, second, and third components are different sizes from each other.

[0093] Embodiment 81. The system of Embodiment 78, wherein the first, second, and third components have different shapes from each other.

[0094] Embodiment 82. The system of Embodiment 75, further comprising third, fourth, and fifth foam components, each of the third, fourth, and fifth components having shapes different from those of the first and second shapes.

[0095] Embodiment 83. The system of Embodiment 75, further comprising third, fourth, and fifth foam components, each of the third, fourth, and fifth components having sizes different from those of the first and second components.

[0096] Embodiment 84. The system of Embodiment 75, wherein the first and second components have first and second mating structures configured to abut each other in a complementary configuration.

[0097] Embodiment 85. The system of Embodiment 84, wherein the mating structures can operate to restrict at least two degrees of freedom of motion of the other component.

[0098] Embodiment 86. The system of Embodiment 84, wherein in the complementary configuration, the first component restricts at least two degrees of freedom of motion of the second component.

[0099] Embodiment 87. The system of Embodiment 84, wherein in the complementary configuration, the first component restricts at least three degrees of freedom of motion of the second component.

[0100] Embodiment 88. The system of Embodiment 87, wherein the first component restricts four, five, or six degrees of freedom of motion of the second component.

[0101] Embodiment 89. The system of Embodiment 84, wherein in the complementary configuration, the first and second components are interconnected to form a composite structure.

[0102] Embodiment 90. The system of Embodiment 84, wherein in the complementary configuration, the first and second components are interconnected to form a composite structure, and wherein the first and second components have different average porosities from each other.

[0103] Embodiment 91. The system of Embodiment 84, further comprising a third foam component having a third mating structure configured to abut at least the first mating structure, wherein in the complementary configuration, the first component restricts at least two degrees of freedom of motion of the third component.

[0104] Embodiment 92. The system of Embodiment 91, wherein the first component restricts four, five, or six degrees of freedom of motion of the third component.

[0105] Embodiment 93. The system of Embodiment 75, wherein the first and second components have different average porosities from each other.

[0106] Embodiment 94. The system of Embodiment 75, wherein the first component comprises a first coating and the second component is substantially free of the first coating.

[0107] Embodiment 95. The system of Embodiment 75, wherein the component further comprises a bioactive coating.

[0108] Embodiment 96. The system of Embodiment 95, wherein the bioactive coating comprises a thrombogenic drug.

[0109] Embodiment 97. The system of Embodiment 75, wherein the component further comprises an expansion-limiting coating configured to control an expansion rate of the component.

[0110] Embodiment 98. A system for treatment of an aneurysm, comprising a plurality of separate and independently expandable components each being expandable from a compressed configuration to an expanded configuration when released into the aneurysm, each of the components having shapes different from each other, wherein the shapes are selected from the group consisting of cylinders, hemispheres, polyhedrons, prolate spheroids, oblate spheroids, plates, bowls, hollow structures, clover shapes, non-spherical surface of revolution, and combinations thereof.

[0111] Embodiment 99. The system of Embodiment 98, wherein the components are different sizes from each other.

[0112] Embodiment 100. The system of Embodiment 98, further comprising at least one additional component that is substantially spherical.

[0113] Embodiment 101. The system of Embodiment 98, further comprising a plurality of additional components that are substantially spherical.

[0114] Embodiment 102. The system of Embodiment 101, wherein the plurality of additional components are different sizes from each other.

[0115] Embodiment 103. The system of Embodiment 98, wherein at least two of the components have mating structures configured to abut each other in a complementary configuration for restricting freedom of motion of the components.

[0116] Embodiment 104. The system of Embodiment 103, wherein the components each have mating structures configured to abut each other in a complementary configuration.

[0117] Embodiment 105. The system of Embodiment 104, wherein in the complementary configuration, the components are interconnected to form a composite structure.

[0118] Embodiment 106. The system of Embodiment 103, wherein in the complementary configuration, the components are interconnected to form a composite structure, and wherein the components have different porosities from each other.

[0119] Embodiment 107. A method for treatment of an aneurysm, comprising: positioning a distal opening of a catheter adjacent to an aneurysm; and releasing a plurality of separate and independently foam components into the aneurysm; wherein shapes of the plurality of components are selected from the group consisting of cylinders, hemispheres, polyhedrons, prolate spheroids, oblate spheroids, plates, bowls, hollow structures, clover shapes, non-spherical surface of revolution, and combinations thereof.

[0120] Embodiment 108. The method of Embodiment 107, wherein the releasing comprises releasing the plurality of components based on a shape of the aneurysm.

[0121] Embodiment 109. The method of Embodiment 108, further comprising selecting the plurality of components based on the shape of the aneurysm.

[0122] Embodiment 110. The method of Embodiment 107, wherein the releasing comprises interconnecting at least two components to create a composite structure.

[0123] Embodiment 111. The method of Embodiment 107, wherein the releasing comprises releasing the plurality of components into the aneurysm to fill the aneurysm such that

as a composite, the plurality of components provides a lower porosity adjacent to a neck of the aneurysm relative to a fundus of the aneurysm.

[0124] Embodiment 112. The method of Embodiment 107, further comprising imaging the aneurysm.

[0125] Embodiment 113. The method of Embodiment 112, wherein the imaging comprises determining a shape of the aneurysm to select the plurality of components.

[0126] Embodiment 114. The method of Embodiment 112, further comprising repositioning a first of the plurality of components within the aneurysm after the first component has been released into the aneurysm.

[0127] Embodiment 115. The method of Embodiment 114, wherein the repositioning comprises repositioning the first component such that the plurality of components, as a composite, is arranged within the aneurysm to provide a lower porosity adjacent to a neck of the aneurysm relative to a fundus of the aneurysm.

[0128] Embodiment 116. The method of Embodiment 107, further comprising, prior to releasing the plurality of components into the aneurysm, implanting a framing device into the aneurysm.

[0129] Embodiment 117. The method of Embodiment 116, wherein the releasing comprises releasing the plurality of components into a cavity of the framing device.

[0130] Embodiment 118. A method for treatment of an aneurysm, comprising: positioning a distal opening of a catheter adjacent to the aneurysm; and advancing a framing device into the aneurysm, the framing device having an interior cavity and an exterior surface for contacting a wall of the aneurysm; and while at least a portion of the device exterior surface is in contact with the aneurysm wall, releasing at least one expandable component into the device cavity; wherein the framing device comprises at least one of a foam or a braided structure.

[0131] Embodiment 119. The method of Embodiment 118, wherein the aneurysm is a saccular aneurysm and before releasing the at least one expandable component, the device is expanded such that the exterior surface contacts an inner surface of the aneurysm having a cross-sectional profile greater than a passing profile of a neck of the aneurysm.

[0132] Embodiment 120. The method of Embodiment 118, wherein the releasing comprises causing the device to expand into contact with the aneurysm wall.

[0133] Embodiment 121. The method of Embodiment 118, wherein the device comprises a substantially closed three-dimensional expanded shape.

[0134] Embodiment 122. The method of Embodiment 118, wherein the component comprises at least one of a foam, a coil, or a braided structure.

[0135] Embodiment 123. The method of Embodiment 121, wherein the three-dimensional shape is selected from the group consisting of spheres, cylinders, hemispheres, polyhedrons, prolate spheroids, oblate spheroids, non-spherical surface of revolution, and combinations thereof.

[0136] Embodiment 124. The method of Embodiment 118, wherein the device comprises for quadrants, and the releasing comprises causing at least a portion of each quadrant to contact the aneurysm wall.

[0137] Embodiment 125. The method of Embodiment 124, wherein the device comprises a substantially spherical expanded shape.

[0138] Embodiment 126. The method of Embodiment 118, wherein the device comprises an opening to the device cavity, and the releasing comprises injecting the at least one expandable component into the device cavity through the device aperture.

[0139] Embodiment 127. The method of Embodiment 126, wherein the device comprises a braided material and the opening is an opening formed between filaments of the braided material.

[0140] Embodiment 128. The method of Embodiment 126, wherein the framing device has a closed end and an open end opposite the closed end, the open end forming the opening, and wherein the releasing advancing comprises aligning the opening with a neck of the aneurysm.

[0141] Embodiment 129. The method of Embodiment 128, wherein the open end comprises a plurality of filament ends extending into the device cavity and forming the opening, the plurality of filament ends collectively forming a tubular portion extending into the device cavity, wherein the releasing comprises permitting the at least one expandable component to expand within the device cavity such that the tubular portion is deflected into contact with an inner wall of the device, thereby closing the opening.

[0142] Embodiment 130. The method of Embodiment 118, wherein the releasing comprises releasing a plurality of expandable components into the aneurysm such that as a

composite, the plurality of expandable components provides a lower average porosity adjacent to a neck of the aneurysm relative to an average porosity at a fundus of the aneurysm.

[0143] Embodiment 131. The method of Embodiment 118, wherein the at least one expandable component comprises a shape selected from the group consisting of cylinders, hemispheres, polyhedrons, prolate spheroids, oblate spheroids, plates, bowls, hollow structures, clover shapes, non-spherical surface of revolution, and combinations thereof.

[0144] Embodiment 132. The method of Embodiment 118, wherein the releasing comprises releasing at least one coil into the device cavity.

[0145] Embodiment 133. The method of Embodiment 118, wherein the releasing comprises releasing at least one expandable component into the device cavity.

[0146] Embodiment 134. The method of Embodiment 133, wherein the at least one expandable component comprises an expandable composite comprising first and second portions having different porosities from each other.

[0147] Embodiment 135. A method for treatment of an aneurysm, comprising: implanting a stent into a lumen of a parent vessel from which an aneurysm arises such that the stent extends across at least a portion of the aneurysm; and releasing at least one expandable component into an inner volume of the aneurysm between a wall of the aneurysm and an outer surface of the stent; wherein the expandable component comprises at least one of a foam or a braided structure.

[0148] Embodiment 136. The method of Embodiment 135, wherein the aneurysm comprises a fusiform aneurysm.

[0149] Embodiment 137. The method of Embodiment 135, wherein the aneurysm comprises a wide-neck aneurysm.

[0150] Embodiment 138. The method of Embodiment 135, wherein the portion comprises a neck.

[0151] Embodiment 139. The method of Embodiment 135, wherein the at least one expandable component comprises a plurality of expandable components, and the releasing comprises releasing the plurality based on relative sizes of the expandable components.

[0152] Embodiment 140. The method of Embodiment 139, further comprising selecting the at least one expandable component based on the shape of the inner volume.

[0153] Embodiment 141. The method of Embodiment 140, wherein the at least one expandable component comprises a shape selected from the group consisting of cylinders, hemispheres, polyhedrons, prolate spheroids, oblate spheroids, plates, bowls, hollow structures, clover shapes, non-spherical surface of revolution, and combinations thereof.

[0154] Embodiment 142. The method of Embodiment 135, wherein the at least one expandable component comprises a first portion having an average porosity greater than that of a second portion thereof, and the releasing comprises positioning the at least one expandable component such that the first portion abuts an outer surface of the stent device and the second portion extends along an inner wall of the aneurysm.

[0155] Embodiment 143. The method of Embodiment 135, wherein the releasing comprises releasing a plurality of expandable components into the inner volume.

[0156] Embodiment 144. The method of Embodiment 135, wherein the aneurysm inner volume extends around a circumference of the stent device, and the releasing comprises depositing a plurality of expandable components into the inner volume around the circumference of the stent device.

[0157] Embodiment 145. The method of Embodiment 144, wherein at least one of the plurality of expandable components comprises a flat or cylindrically shaped surface, and the releasing comprises positioning the at least one of the plurality of expandable components such that the flat or cylindrically shaped surface substantially conforms to an outer surface of the stent device.

[0158] Embodiment 146. A system for treatment of an aneurysm, comprising: an intrasaccular device comprising first and second expandable components adapted to transition from a compressed configuration to an expanded configuration when deployed into the aneurysm, the first and second components being interconnected by a non-helical coupling such that the first and second components can be advanced as an interconnected unit, into the aneurysm; wherein the first component comprises at least one of a shape or an average porosity different from a shape or an average porosity of the second component.

[0159] Embodiment 147. The system of Embodiment 146, wherein the first component shape is selected from the group consisting of cylinders, hemispheres, polyhedrons, prolate spheroids, oblate spheroids, plates, bowls, hollow structures, clover shapes, non-spherical surface of revolution, and combinations thereof.

[0160] Embodiment 148. The system of Embodiment 146, wherein the second component comprises a substantially spherical shape.

[0161] Embodiment 149. The system of Embodiment 146, wherein at least one of the first or second components comprises a foam or a braided structure.

[0162] Embodiment 150. The system of Embodiment 146, wherein at least one of the first or second components comprises a coil.

[0163] Embodiment 151. The system of Embodiment 146, wherein the first component comprises an average porosity of between about 1 μm and about 100 μm and the second component comprises an average porosity of between about 100 μm and about 200 μm

[0164] Embodiment 152. The system of Embodiment 146, further comprising a third component interconnected with the second component such that the first, second, and third components are interconnected in series.

[0165] Embodiment 153. The system of Embodiment 146, wherein the coupling interconnecting the first and second components comprises a filament.

[0166] Embodiment 154. The system of Embodiment 146, wherein the coupling has a preset shape such that in an expanded position, the first and second components are spaced relative to each other at a preset orientation.

[0167] Embodiment 155. The system of Embodiment 146, further comprising an introducer sheath configured to receive the device therein such that the device can be loaded into the guide catheter for delivery to the aneurysm.

[0168] Embodiment 156. A system for treatment of an aneurysm, comprising: an intrasaccular device comprising at least three expandable components adapted to transition from a compressed configuration to an expanded configuration when deployed into the aneurysm, each of the at least three components being interconnected to at least two of the at least three components such that at least three expandable components can be advanced as an interconnected unit, into the aneurysm.

[0169] Embodiment 157. The system of Embodiment 156, wherein the at least three expandable components comprises at least four expandable components.

[0170] Embodiment 158. The system of Embodiment 157, wherein at least two of the at least four expandable components is interconnected with at least three of the at least four expandable components such that the device comprises a multi-planar shape.

[0171] Embodiment 159. The system of Embodiment 156, wherein the at least three components are interconnected by filaments.

[0172] Embodiment 160. The system of Embodiment 156, wherein at least three components are interconnected by filaments having preset shapes such that in an expanded position, the at least three components are spaced relative to each other at a preset orientation.

[0173] Embodiment 161. The system of Embodiment 156, wherein the device comprises at least one central expandable component positioned such that, when the device is in an expanded configuration, the central expandable component is centrally interconnected with a plurality of the expandable components.

[0174] Embodiment 162. The system of Embodiment 161, wherein the at least one central expandable component has an expanded size greater than an expanded size of each remaining one of the plurality of components.

[0175] Embodiment 163. The system of Embodiment 161, wherein the at least one central expandable component has an average porosity greater than an average porosity of each remaining one of the plurality of the components.

[0176] Embodiment 164. The system of Embodiment 158, wherein the multi-planar shape comprises a polyhedron.

[0177] Embodiment 165. The system of Embodiment 164, wherein the multi-planar shape comprises a pyramid.

[0178] Embodiment 166. The system of Embodiment 164, wherein the multi-planar shape comprises a prism.

[0179] Embodiment 167. The system of Embodiment 156, wherein a first component of the at least three components comprises a shape or an average porosity different than that of a second component of the at least three components.

[0180] Embodiment 168. The system of Embodiment 156, wherein the first component shape is selected from the group consisting of cylinders, hemispheres, polyhedrons, prolate spheroids, oblate spheroids, plates, bowls, hollow structures, clover shapes, non-spherical surface of revolution, and combinations thereof.

[0181] Embodiment 169. The system of Embodiment 156, wherein the second component comprises a substantially spherical shape.

[0182] Embodiment 170. The system of Embodiment 156, wherein the first component comprises an average porosity of between about 1 μm and about 100 μm , and the second component comprises an average porosity of between about 100 μm and about 200 μm .

[0183] Embodiment 171. The system of Embodiment 156, further comprising an introducer sheath configured to receive the device therein such that the device can be loaded into the guide catheter for delivery to the aneurysm.

[0184] Embodiment 172. A method for treatment of an aneurysm, comprising: advancing an intrasaccular device toward the aneurysm through a lumen of a catheter, the device comprising a plurality of expandable components each adapted to transition from a compressed configuration to an expanded configuration when deployed into the aneurysm from the catheter, each of the plurality of components being interconnected by a coupling.

[0185] Embodiment 173. The method of Embodiment 172, further comprising: advancing the device into the aneurysm such that a first component is disposed within the aneurysm and a second component, interconnected with the first component by the coupling, is disposed within the catheter lumen; severing the coupling between the first and second components to release the first component into the aneurysm; retaining the second component within the lumen; and withdrawing the catheter.

[0186] Embodiment 174. The method of Embodiment 172, further comprising advancing a plurality of expandable components into the aneurysm prior to the severing.

[0187] Embodiment 175. The method of Embodiment 172, wherein each of the plurality of components is interconnected in series by the coupling.

[0188] Embodiment 176. The method of Embodiment 172, wherein the severing comprises proximally withdrawing the catheter relative to a second catheter such that the coupling between the first and second components is pinched between a distal end of the catheter and a rim of the second catheter.

[0189] Embodiment 177. The method of Embodiment 172, wherein the plurality of expandable components is arranged in descending size, and the advancing comprises allowing an initial expandable component deployed into the aneurysm to expand prior to advancing a subsequent expandable component into the aneurysm.

[0190] Embodiment 178. The method of Embodiment 177, wherein the advancing comprises observing a fit of expanded components within the aneurysm to determine whether to advance additional components into the aneurysm.

[0191] Embodiment 179. The method of Embodiment 178, wherein the device comprises a radiopaque material.

[0192] Embodiment 180. The method of Embodiment 178, wherein the couplings between the plurality of expandable components comprise a radiopaque material.

[0193] Embodiment 181. The method of Embodiment 178, wherein each of the plurality of expandable components of the device comprises a radiopaque material.

[0194] It is to be understood that both the foregoing general description and the following detailed description are exemplary and explanatory and are intended to provide further explanation of the subject technology.

BRIEF DESCRIPTION OF THE DRAWINGS

[0195] The accompanying drawings, which are included to provide further understanding of the subject technology and are incorporated in and constitute a part of this specification, illustrate aspects of the disclosure and together with the description serve to explain the principles of the subject technology.

[0196] Figure 1 is a schematic illustration depicting an aneurysm within a blood vessel, into which an intrasaccular device has been implanted, according to some embodiments.

[0197] Figure 2 is a schematic view of reticulated foam, which can be used in the intrasaccular device accordance with some embodiments.

[0198] Figure 3 is a schematic view an intrasaccular device having a specific porosity, according to some embodiments.

[0199] Figure 4 is a schematic view of an intrasaccular device comprising two portions having different porosities, according to some embodiments.

[0200] Figure 5 is an enlarged view of a transition zone of the intrasaccular device shown in Figure 4, wherein the transition zone comprises an immediate transition between different porosities, according to some embodiments.

[0201] Figure 6 is an enlarged view of the transition zone of the intrasaccular device shown in Figure 4, wherein the transition zone comprises a gradual transition between different porosities, according to some embodiments.

[0202] Figure 7 is a schematic view of an intrasaccular device comprising three portions arranged in a specific porosity profile, according to some embodiments.

[0203] Figure 8 is a schematic view of an intrasaccular device comprising three portions arranged in a specific porosity profile, according to some embodiments.

[0204] Figure 9 is a schematic view of an intrasaccular device comprising four portions having different porosities, according to some embodiments.

[0205] Figure 10 is a schematic view of an intrasaccular device having channels extending therethrough, according to some embodiments.

[0206] Figure 11 is a schematic view of an intrasaccular device having a channel extending therethrough, according to some embodiments.

[0207] Figures 12A–12R are views illustrating alternate configurations for the foam structures of the intrasaccular device;

[0208] Figures 13–15 illustrate hollow structures of an intrasaccular device, according to some embodiments.

[0209] Figures 16–18 illustrate interlocking structures of an intrasaccular device, according to some embodiments.

[0210] Figures 19–21 illustrate alternate embodiments of the intrasaccular device incorporating coated foam structures.

[0211] Figure 22–25 illustrate a delivery system and a procedure for delivering an intrasaccular device, according to some embodiments.

[0212] Figure 26 illustrates an intrasaccular device having a radiopaque material and positioned within an aneurysm, according to some embodiments.

[0213] Figures 27–30 illustrate intrasaccular devices positioned within an aneurysm based on a porosity profile, according to some embodiments.

[0214] Figures 31A–34 illustrate alternative engagement mechanisms for the delivery system shown in Figure 22, for engaging one or more expandable components, according to some embodiments.

[0215] Figure 35 illustrates a delivery system for delivering an intrasaccular device, according to some embodiments.

[0216] Figure 36 illustrates a delivery system for delivering an intrasaccular device comprising a plurality of expandable components, according to some embodiments.

[0217] Figure 37 illustrates a delivery system, advanceable along a guide wire, for delivering an intrasaccular device comprising a plurality of expandable components, according to some embodiments.

[0218] Figure 38 illustrates an intrasaccular device having a specific shape and a radiopaque material positioned within a saccular aneurysm, according to some embodiments.

[0219] Figure 39 illustrates an intrasaccular device comprising a plurality of expandable components positioned within a saccular aneurysm, according to some embodiments.

[0220] Figure 40 illustrates an intrasaccular device comprising a plurality of interlocking expandable components positioned within a saccular aneurysm, according to some embodiments.

[0221] Figure 41 illustrates an intrasaccular device comprising a plurality of expandable components positioned within a saccular aneurysm, according to some embodiments.

[0222] Figure 42 illustrates an intrasaccular device comprising a plurality of expandable components extending across a fusiform aneurysm, according to some embodiments.

[0223] Figure 43 illustrates a schematic view of a procedure in which an embolic liquid and an intrasaccular device comprising single expandable component are inserted into an aneurysm, according to some embodiments.

[0224] Figure 44 illustrates a schematic view of a procedure in which an embolic liquid and an intrasaccular device comprising a plurality of expandable components are inserted into an aneurysm, according to some embodiments.

[0225] Figure 45 illustrates a delivery procedure for delivering coils or foam within an interior of an intrasaccular framing device, according to some embodiments.

[0226] Figure 46 illustrates a partial cross-sectional view of the intrasaccular framing device as similarly shown in Figure 45, packed with coils, according to some embodiments.

[0227] Figure 47 illustrates a partial cross-sectional view of the intrasaccular framing device as similarly shown in Figure 45, packed with at least one foam component, according to some embodiments.

[0228] Figure 48 illustrates another embodiment of an intrasaccular framing device, packed with at least one foam component, according to some embodiments.

[0229] Figure 49 illustrates yet another embodiment of an intrasaccular framing device, packed with at least one foam component, according to some embodiments.

[0230] Figures 50–52 are schematic views of different intrasaccular framing devices, according to some embodiments.

[0231] Figures 53–56 illustrate embodiments of the intrasaccular device incorporating a strip of foam structures.

[0232] Figures 57A–57C illustrate cross-sectional shapes that can be employed, alone or in combination with each other, in the intrasaccular structures shown in Figures 53–56.

[0233] Figure 58A illustrates an embodiment of an intrasaccular device comprising a plurality of interconnected expandable components in a compressed state, according to some embodiments.

[0234] Figure 58B illustrates the intrasaccular device of Figure 58A comprising a plurality of interconnected expandable components in an expanded state, according to some embodiments.

[0235] Figure 59A illustrates an embodiment of an intrasaccular device comprising a layer of interconnected expandable components in a compressed state, according to some embodiments.

[0236] Figure 59B illustrates another embodiment of an intrasaccular device comprising a layer of interconnected expandable components in a compressed state, according to some embodiments.

[0237] Figure 60A illustrates an embodiment of an intrasaccular device comprising a three-dimensional array of interconnected expandable components in a compressed state, according to some embodiments.

[0238] Figure 60B illustrates another embodiment of an intrasaccular device comprising a three-dimensional array of interconnected expandable components in a compressed state, according to some embodiments.

[0239] Figure 61–63 illustrate a delivery system and procedure for delivering a plurality of interconnected expandable components, according to some embodiments.

DETAILED DESCRIPTION

[0240] In the following detailed description, numerous specific details are set forth to provide a full understanding of the subject technology. It should be understood that the subject technology may be practiced without some of these specific details. In other instances, well-structures and techniques have not been shown in detail so as not to obscure the subject technology.

[0241] Intracascular implant devices and procedures for treating aneurysms can be improved by manipulating one or more physical characteristics of the implant material. Such characteristics can include the porosity, composition, material, shape, size, interconnectedness, inter-engagement, coating, etc. By modifying one or more such characteristics, the morphology or attributes of a target aneurysm and orientation of any connecting arteries can be specifically considered and addressed to achieve superior treatment.

[0242] According to some embodiments, the porosity, composition, or material of the intracascular device can facilitate in the treatment of an aneurysm. The intracascular device can comprise an expandable component. The intracascular device can expand from a first, compressed configuration to a second, expanded configuration when released into the aneurysm.

[0243] Optionally, the intracascular device can comprise an expandable component having an average porosity that changes from a first end of the component to a second end opposite the first end. Optionally, the intracascular device can comprise a composite structure having first and second sections or materials having different porosities. For example, the first and second sections can be separated by a transition zone. The transition zone can comprise an immediate change in porosity or a gradual transition in which the porosity spatially varies between a first porosity and a second porosity from one end of the transition zone to another, opposite end of the transition zone.

[0244] As used herein, "porosity" can generally refer to an average porosity, which can be sampled across a given portion or section of an expandable component. "Porosity" can be defined as the ratio of the volume of the pores of in a component to the volume of the component as a whole. Porosity can be measured by a fluid displacement test. For example, liquid or gas testing can be used, as necessary or desirable, according to skill in the art. In some embodiments, a chromatography chamber can be used to measure displacement of a gas within the chamber, enabling the calculation of an average porosity of a given intracascular device or portion thereof.

Other methods and systems can be used to measure porosity of portions of or the entirety of an expandable component.

[0245] In some embodiments, a composite structure of the intrasaccular device can comprise three materials having different porosities. Further, the composite structure of the intrasaccular device can comprise four, five, six, or more different materials having different porosities.

[0246] According to some embodiments, one or more of intrasaccular devices can be released into a target aneurysm and, in some embodiments, specifically oriented relative to the aneurysm ostium or neck and/or one or more perforating vessels (e.g., perforating arteries or arterioles) adjacent to the aneurysm.

[0247] In some embodiments, the intrasaccular device can be repositioned within the aneurysm as the device is expanding. The repositioning of the device can allow a clinician to position a lower porosity section of the device adjacent to the neck of the aneurysm. The repositioning of the device can also allow a clinician to position a higher average porosity section of the device adjacent to one or more perforating vessels (e.g., perforating arteries or arterioles) adjacent to the aneurysm. The repositioning of the device can also allow a clinician to position a lower porosity portion of the device adjacent to a bifurcation. The repositioning of the device can also allow a clinician to position a higher average porosity portion of the device toward or in the fundus of the aneurysm.

[0248] Intrasaccular implant devices and procedures for treating aneurysms disclosed herein can also comprise manipulating a shape or size of the intrasaccular device. According to some embodiments, a single expandable component having a specific or selected shape or size, which can be tailored to the shape or size of the aneurysm, can be implanted into an aneurysm. Further, multiple expandable components, each having such a specific or selected shape or size can also be implanted into an aneurysm. The shape or size of the expandable component(s) can be selected from a variety of spherical or non-spherical shapes. Each shape can be solid or hollow.

[0249] According to some embodiments, a composite intrasaccular device can be provided that comprises at least two mating expandable components (e.g., a plurality of interconnectable or engageable expandable components). Each of the expandable components

can comprise one or more engagement structures configured to interact with a corresponding engagement structure of another mating expandable component.

[0250] For example, the mating expandable components can each comprise an engagement structure configured to interact with a corresponding engagement structure of another mating expandable component. The mating expandable components can be delivered into the aneurysm and arranged in situ such that the engagement structures are aligned and interconnected appropriately such that the expandable components are mated. In some embodiments, the mating of the expandable components can interlock the components as a unit. For example, expansion of a portion of a component within a recess of another component can cause the components to be interlocked with each other. Further, in some embodiments, the mating components can restrict at least one degree of freedom of movement of another component.

[0251] According to some embodiments in which a plurality of expandable components is used, the expandable components (whether interconnected by wires or filaments, or not interconnected, thereby moving independently of each other) can be arranged in a pattern to provide a composite component. The composite component can provide desired characteristics that may be difficult to achieve in a single component formed from a single, continuous piece of material.

[0252] A variety of delivery systems and procedures can be implemented to deliver an intrasaccular device having a specific size or shape and, in some embodiments, having a plurality of expandable components. Examples of these systems and procedures are discussed further herein.

[0253] In accordance with some embodiments of the delivery procedure, the target aneurysm can be imaged and analyzed in order to determine a three-dimensional shape of the aneurysm. Based on the shape of the target aneurysm, one or more expandable components can be selected, having a unique porosity, composition, material, shape, size, interconnectedness, inter-engagement, or coating, etc. Imaging devices can include 3-D CTA or MRI (MRA) imaging, through which the size and shape of the aneurysm can be ascertained. Such imaging can provide a basis for selection of one or more correspondingly shaped intrasaccular device(s) for insertion within the aneurysm. Different combinations of expandable components or their characteristics can be used.

[0254] Optionally, in some embodiments, the intrasaccular device can have a predetermined configuration, whether or not the intrasaccular device has only a single or multiple expandable components. The predetermined configuration can be based on typical aneurysm shapes, thereby allowing selection of a specific intrasaccular device. However, individual components of an intrasaccular device can also be arranged based on their properties. Accordingly, the clinician can determine the shape of the aneurysm and create a desired intrasaccular device configuration for treating the aneurysm.

[0255] In some embodiments, an expandable component of an intrasaccular device may be molded or manufactured into a variety of geometrical or partial geometrical shapes.

[0256] For example, in order to accommodate a variety of aneurysm configurations, the shape or size of the expandable component(s) can be selected from a variety of spherical or non-spherical shapes, including, cylinders, hemispheres, noodles, polyhedrons (e.g., cuboids (types), tetrahedrons (e.g. pyramids), octahedrons, prisms), coils, prolate spheroids, oblate spheroids, plates (e.g., discs, polygonal plates), bowls (e.g., an open container, such as a hollow, hemispherical container or other open, hollow containers, whether hemispherical, rounded, or otherwise), hollow structures (e.g., a container of any shape with an inner cavity or void, which can be, for example, greater in size than a width of any of the walls of the structure), clover shapes (a plurality of radially extending protrusions, having rounded or smooth corners), non-spherical surfaces of revolution (e.g., toruses, cones, cylinders, or other shapes rotated about a center point or a coplanar axis), and combinations thereof. Each shape(s) can be solid or hollow.

[0257] In accordance with some embodiments, at least a portion of the intrasaccular device can comprise a coating or material for enhancing therapeutic, expansive, or imaging properties or characteristics of at least one or every expandable component of the intrasaccular device.

[0258] In some embodiments, the intrasaccular device can be configured such that an expandable component thereof is coated with a biocompatible material to promote endothelialization or provide a therapeutic effect.

[0259] Optionally, the expandable component can also comprise an expansion-limiting coating that slows expansion of the component from its natural rate of expansion to a slower rate of expansion such that in the process of expanding, the position of the component can be adjusted within the aneurysm or the component can be removed from the aneurysm, if

necessary. Examples of polymers that can be used as expansion-limiting coatings can include hydrophobic polymers, organic non-polar polymers, PTFE, polyethylene, polyphenylene sulfide, oils, and other similar materials.

[0260] Various delivery systems and procedures can be implemented for delivering an intrasaccular device comprising one or more expandable components, as discussed herein. Further, a system and method are provided for delivery of an intrasaccular device to an aneurysm and/or recapturing the device for removal or repositioning.

[0261] Intrasaccular implant devices and procedures for treating aneurysms can comprise interconnecting individual components of the intrasaccular device. According to some embodiments, a plurality of expandable components can be interconnected along a wire, filament, or other disconnectable or breakable material. The expandable components can be connected in a linear configuration, a planar matrix, or in a three-dimensional matrix. The expandable components of such interconnected linear, planar, or three-dimensional matrices can be sized and configured in accordance with desired porosity, size, shape, radiopacity, or other characteristics disclosed herein.

[0262] In some embodiments, methods are provided by which interconnected expandable components can be released into an aneurysm. The interconnected components can be preconfigured (e.g., a plurality of components can be joined together to form a single, unitary device, or a select plurality of components can be removed from a larger strand or array of components) prior to implantation and later inserted into a delivery catheter. Thereafter, the entire strand or assembly of interconnected expandable components of the intrasaccular device can be ejected or released into the aneurysm and allowed to expand within the aneurysm.

[0263] However, in accordance with some embodiments, an entire strand or array of components can be loaded into a delivery catheter, and while implanting and observing the packing behavior, a clinician can determine that a select portion of the interconnected expandable components is sufficient for a given aneurysm. Thereafter, the select portion of the interconnected expandable components can be broken or cut in situ so as to be released into the aneurysm.

[0264] Additionally, although in some embodiments, a single expandable component can be used alone to fill the aneurysm and provide a desired packing density, a plurality of expandable components can also be used to fill the aneurysm and provide a desired packing

density. Optionally, a liquid embolic and/or a framing component can be used in combination with one or more expandable components to facilitate delivery, engagement with the aneurysm, or increase of the packing density. Any of these embodiments can allow increased packing density to avoid recanalization of the aneurysm.

[0265] Referring now to the drawings, Figure 1 illustrates an embodiment of an intrasaccular device 10 positioned within an aneurysm 12 in a blood vessel 14. The intrasaccular device 10 can be particularly adapted for use in the tortuous neurovasculature of a subject for at least partial deployment in a cerebral aneurysm.

[0266] A cerebral aneurysm may present itself in the shape of a berry, i.e., a so-called berry or saccular aneurysm, which is a bulge in the neurovascular vessel. Berry aneurysms may be located at bifurcations or other branched vessels. Other types of aneurysms, including fusiform aneurysms, can also be treated using embodiments of the intrasaccular devices disclosed herein.

[0267] The intrasaccular device 10 can comprise at least one expandable component. In some embodiments, the intrasaccular device 10 can comprise a plurality of expandable components. Further, a given expandable component of the intrasaccular device 10 can have one or more different characteristics than another of the expandable components of the intrasaccular device 10.

[0268] An expandable component can be formed from a material that can be highly compressed and later expanded when released into the aneurysm and contacted by a fluid, such as a fluid within the aneurysm. In some embodiments, the expandable component can be formed at least in part of biocompatible, solid foam. As disclosed herein, "foam" can include a solid or semisolid gel, a swellable material (whether swellable upon hydration or swellable/self-expanding without hydration), a material having pores and interstices. "Foam" can include hydrophobic or hydrophilic materials. "Foam" can also include materials that can be highly compressed and configured to expand upon contact with a fluid, upon exposure to a thermal agent, upon exposure to a chemical agent, or self-expanding, upon release from engagement with the delivery mechanism. In some embodiments, the foam material can be configured to expand by about two, three, four, five, six, seven, eight, nine, ten, eleven, twelve, thirteen, fourteen, fifteen, sixteen, seventeen, eighteen, nineteen, twenty, or more times its collapsed size when expanding to its expanded size.

[0269] For example, Figure 2 illustrates a schematic view of a foam material 20. Suitable foam materials can comprise biocompatible foams such as a PVA (polyvinyl alcohol). Further, suitable foam materials can comprise reticulated foam. "Reticulated" foam can, in some embodiments, comprise a random arrangement of holes that has irregular shapes and sizes or a nonrandom arrangement of holes that has regular, patterned shapes and sizes. Suitable foam is also known under the trade name PacFoam, made available through UFP Technologies of Costa Mesa, California. In some embodiments, the foam material from which the expandable component is formed can be configured to include at least about 20 pores per inch ("PPI"), at least about 30 PPI, at least about 40 PPI, at least about 50 PPI, at least about 60 PPI, at least about 70 PPI, or at least about 80 PPI, or combinations thereof.

[0270] Other materials can also be used to form one or more portions of an intrasaccular device or an expandable component thereof. Such materials can include, but are not limited to polyvinyl alcohol (PVA) materials, water-soluble synthetic polymers, such as polyethylene glycol (PEG), polyvinyl pyrrolidone (PVP), and other similar materials.

[0271] The porosity of the expandable component may vary along any portion(s) thereof, including any combination of pore sizes of 1 micron or greater. Further, the pore sizes can range from about 1 μm to about 400 μm , from about 5 μm to about 300 μm , from about 8 μm to about 200 μm , from about 10 μm to about 150 μm , from about 15 μm to about 80 μm , or in some embodiments, from about 20 μm to about 50 μm . Further, at least a portion or section of the device can comprise an average porosity of between about 1 μm and about 150 μm . Further, at least a portion or section can comprise an average porosity of between about 100 μm and about 200 μm . Furthermore, at least a portion or section can comprise an average porosity of between about 200 μm and about 300 μm . When a composite expandable component is formed using multiple sections or portions, each section or portion can have an average porosity within any of the ranges discussed above.

[0272] According to some embodiments, in a compressed state, an expandable component of the intrasaccular device may be compressed down to 50%, 40%, 30%, 20%, 10% or less of its expanded state (which can be measured by its maximum diameter or cross-sectional dimension) for delivery through a standard microcatheter. In some embodiments, the foam material can be configured to expand by about two to twenty times its collapsed size when expanding to its expanded size.

[0273] In the event the intrasaccular device is not self-expandable, but expandable through a chemical reaction, a chemical may be introduced within the lumen of the delivery catheter for delivery to the intrasaccular device. In the alternative, the delivery catheter may include a separate lumen for introduction of the catalyst. Thermally expansive foam may be activated through introduction of heated saline or some other suitable biocompatible fluid through any of the aforementioned lumens of the delivery catheter. In the alternative, a heating element may be incorporated within the delivery catheter to deliver heat to the foam structure to cause corresponding expansion. A suitable heating element, identified schematically as reference numeral, may include resistive element(s), a microwave antenna, radio-frequency means, ultrasonic means or the like.

[0274] As noted above, some embodiments of the expandable component can be configured to provide a specific porosity profile. The porosity profile can comprise a single, consistent average porosity throughout the entire expandable component, or multiple average porosity zones, portions, or materials having different average porosities that are joined to form a composite expandable component.

[0275] For example, the embodiment illustrated in Figure 3 can be configured to have a low average porosity structure. For purposes of illustration, low porosity structures are illustrated in the figures using hexagonal patterns with larger spaces compared to hexagonal patterns with smaller spaces, which are used to illustrate medium and high porosity structures. Low porosity structures can provide higher packing densities, which can facilitate thrombogenesis by providing higher resistance to flow therethrough. When such low porosity structures are implanted into an aneurysm, such structures can substantially pack the aneurysm with a relatively high packing density, thereby isolating the aneurysm from the parent vessel and minimizing blood flow velocity within the aneurysm while supporting the aneurysm wall.

[0276] Conversely, as porosity increases, the packing density decreases, which compared to low porosity structures, provides less support for thrombogenesis due to lower resistance to flow therethrough. Nevertheless, the realization of some embodiments disclosed herein is that high porosity structures can also support the aneurysm wall, beneficially aid in healing and thrombogenesis for select aneurysm morphologies, permit flow to other vessels (e.g., branch vessels, perforating arteries, or arterioles), and/or permit the introduction of other materials, such as a liquid embolic, etc.

[0277] Further, in some embodiments, composite, variable, or multi-porosity expandable components (whether using a single expandable component having multiple porosities or using multiple expandable components each having different porosities) can advantageously allow the intrasaccular device to mimic natural function of the vasculature while promoting healing through thrombogenesis, pressure moderation or reduction, or aneurysm deflation. Further, in embodiments using a single expandable component, the single expandable component can be configured to advantageously secure the intrasaccular device within a wide-neck aneurysm by facilitating engagement with a sufficient amount of the aneurysm wall, thereby avoiding dislodgement or herniation of the device from the aneurysm into the parent vessel.

[0278] Figure 3 illustrates an expandable component 50 having a relatively less dense or high porosity due to a larger pore size. As noted above, the foam component 50 can permit some blood flow therethrough to maintain branch vessels while still providing support for the aneurysm wall. Further, in accordance with some embodiments, the expandable component 50 or a portion of the expandable component 50 can be packed with a liquid embolic during or subsequent to placement of the intrasaccular device. The injection of a liquid embolic can increase the overall packing density within the expandable component 50.

[0279] One suitable liquid embolic is the Onyx™ liquid embolic system manufactured by Covidien LP, Irvine, CA. Onyx™ liquid embolic system is a non-adhesive liquid used in the treatment of brain arteriovenous malformations. Onyx™ liquid embolic system is comprised of an EVOH (ethylene vinyl alcohol) copolymer dissolved in DMSO (dimethyl sulfoxide), and suspended micronized tantalum powder to provide contrast for visualization under fluoroscopy. Other liquid embolic solutions are also envisioned.

[0280] Figures 4–9 illustrate additional embodiments of expandable components. For example, Figure 4 illustrates an expandable component 60 having first and second portions 62, 64. The first and second portions 62, 64 can be formed from different materials. For example, the first portion 62 can comprise a higher average porosity first material, and the second portion 64 can comprise a lower average porosity second material. The first and second portions 62, 64 can be coupled to each other by any chemical, thermal, or mechanical bonding methods known in the art or arising hereafter. The first and second portions 62, 64 can be permanently attached to each other or releasably, upon expansion, attached to each other.

[0281] Figures 5–6 illustrate enlarged views of a transition zone 66 of the expandable component 60 of Figure 4. In accordance with some embodiments, Figure 5 illustrates that a transition zone 66a can comprise an immediate, abrupt transition between the porosities of the first and second portions 62, 64. The transition zone 66a provides an open flow pathway between the first and second portions 62, 64. Thus, the transition zone 66a may not act as a barrier to fluid flow. However, in some embodiments, the transition zone 66a can provide at least a partial or full barrier to fluid flow between the first and second portions 62, 64. In such embodiments, the composite structure of the expandable component 60 may incorporate individual, separately formed segments or sections of material that are later joined together to create a composite unit or whole. The individual segments or first and second portions 62, 64 may comprise the same material (such as any of those mentioned herein), or incorporate a combination of different materials. The first and second portions 62, 64 may be bonded by any chemical, thermal, or mechanical methods known in the art.

[0282] Figure 6 illustrates that a transition zone 66b can comprise an intermediate portion 68 having an average porosity that is higher than the average porosity of the second section 64, but lower than the average porosity of the first section 62. The transition zone 66b provides an open flow pathway between the first, second, and/or intermediate portions 62, 64, 68. Thus, similar to the transition zone 66a, the transition zone 66b may not act as a barrier to fluid flow. However, in some embodiments, the transition zone 66b can provide at least a partial or full barrier to fluid flow between the first, second, and/or intermediate portions 62, 64, 68. In such embodiments, the intermediate portion 68 can have a porosity that gradually transitions spatially from a low porosity to a high porosity, or vice versa. The transition zone 66b can be formed by varying the gas used in the fabrication of the variable porosity structure. Further, during manufacturing of the expandable component 60, regions within the blank can be identified based on an average porosity and the expandable component can be trimmed therefrom. In some embodiments, certain regions can be identified that have a porosity that varies spatially from one end of the region to another, opposite end.

[0283] Figures 7–9 illustrate schematic views of additional embodiments of expandable components shown in Figures 1–4. These figures illustrate expandable components that each include a composite structure having two or more foam segments with different respective porosities (or pore densities), sizes, and/or shapes.

[0284] For example, Figure 7 illustrates an expandable component 80 having first, second, and third portions 82, 84, 86. The second portion 84 can comprise a lower porosity than the first and third portions 82, 86. In some embodiments, the first and third portions 82, 86 can comprise the same porosity (e.g., the first and third portions 82, 86 can comprise the same material or be formed or cut from the same material). However, in some embodiments, the first and third portions 82, 86 can comprise different porosities (e.g., the first and third portions 82, 86 can comprise different materials or be formed or cut from different materials). Additionally, the first, second, and third portions 82, 84, 86 can comprise different sizes and/or shapes or have substantially identical sizes and/or shapes. Size and shape characteristics can be configured as discussed below, in accordance with some embodiments.

[0285] Figure 8 similarly illustrates an expandable component 90 having first, second, and third portions 92, 94, 96. In general, the second portion 94 comprises a higher porosity than the first and third sections 92, 96. Additionally, Figure 9 also illustrates expandable component 100 having first, second, third, and fourth sections 102, 104, 106, 108, which can each have distinct porosities, shapes, and/or sizes. The porosity, size, or shape of the portions of the expandable components 90, 100 can be configured as similarly discussed above with respect to Figure 7. Accordingly, the discussion of such characteristics will not be repeated except to indicate that Figures 8–9 illustrate that some embodiments can incorporate varied porosities, sizes, and shapes different from those illustrated Figure 7.

[0286] The foam composites may be formed to provide different support and/or flow profiles. As addressed herein, a material, such as bismuth or tantalum, can be blended with the foam to provide radiopacity. Also, radiopaque markers can be attached to the foam by bonding or mechanically crimping them to the foam.

[0287] As noted above, in some embodiments, only a single expandable component would be required for introduction into an aneurysm. In some embodiments, this may prove advantageous over conventional methodologies such as the insertion of, for example, multiple embolic coils, by significantly reducing time for performance of the embolization procedure.

[0288] Additionally, in some embodiments, multiple expandable components can be provided for insertion into an aneurysm. For example, a plurality of expandable components, having different average porosities, can be implanted into an aneurysm and have a composite or cumulative porosity profile spatially across the aneurysm, which can allow the plurality of

expandable components to operate as a unit in much the same way as a single expandable component, if packing the same aneurysm itself, would operate. Such embodiments are discussed in greater detail below in Figures 36–42. The expandable components can be arranged and positioned within a lumen of the catheter or otherwise arrange for delivery into the aneurysm. The size of each expandable component can be compressed to a fraction of its normal, expanded size and delivered into the target aneurysm.

[0289] Further, in some embodiments, the expandable component(s) can include one or more flow regions. The flow region can be used alone or combination with any of the variable porosity profiles disclosed herein, including those illustrated in Figures 4–9.

[0290] For example, Figures 10–11 illustrate expandable components having at least one flow region. Figure 10 illustrates an expandable component 30 having a pair of flow regions 32 formed in a body 34. Figure 11 similarly illustrates another embodiment of an expandable component 40 having a single flow region 42 formed in a body 44. While the body 34, 44 can have a substantially constant porosity that impedes fluid flow and generally promotes thrombogenesis, the flow regions 32, 42 can be configured such that fluid flow through the flow regions is possible. For example, the flow regions 32, 42 of the expandable components 30, 40 can provide a flow path for blood or enable performance of a secondary procedure, such as the introduction of an embolic, anti-inflammatory, antibiotic, or thrombogenic agent and/or permit deployment of embolic coils within the expandable components 30, 40. Either of these components 30, 40 may allow blood to communicate to a side branch vessel through areas of the expandable component with large porosity while still providing stasis in the aneurysm.

[0291] According to some embodiments, the flow regions 32, 42 can comprise a passage, channel, or elongate void within the body 34, 44. Further, in embodiments wherein the flow regions 32, 42 comprise a material, the material of the flow regions 32, 42 can have a much higher porosity than that of the surrounding areas within the body 34, 44. Although Figures 10–11 illustrate only single or dual flow regions, some embodiments can be configured to comprise three, four, or more flow regions formed therein.

[0292] In some embodiments, the flow region can be separated from other portions of the body by a partial or full barrier. For example, the flow region can comprise a lumen formed through the body and the lumen can comprise an inner wall (not shown) extending therealong. The inner wall can comprise a continuous surface. However, the inner wall can also comprise

one or more perforations extending through the wall, by which the lumen of the flow region is in fluid communication with the surrounding areas of the body. Thus, the flow region can provide isolated flow through the body or a flow that is in communication with other areas of the body of the expandable component.

[0293] Figures 12A–12R illustrate various examples of shapes that can be used in accordance with some embodiments. Variations, whether by proportions, combinations, or other modifications of the disclosed shapes can be made, as taught herein. Without limitation, the shapes illustrated in Figures 12A–12R can comprise a sphere 120, a hemisphere 121, a cuboid 122, a pyramid 123, an octahedron 124, an octagonal prism 125, a pentagonal prism 126, a coil 127, a prolate spheroid 128, an oblate spheroid 129, a clover plate 130, a star plate 131, a paraboloid of revolution 132, a hollow sphere 133, a bowl 134, a torus 135, a cylinder 136, a cone 137, or combinations thereof.

[0294] In particular, in some embodiments, an intrasaccular device can be provided that comprises first and second expandable components of which at least one has a shape selected from the group consisting of cylinders, hemispheres, polyhedrons, prolate spheroids, oblate spheroids, plates, bowls, hollow structures, clover shapes, non-spherical surface of revolution, and combinations thereof. Additional expandable components can be provided that have substantially spherical shapes.

[0295] In accordance with some embodiments, an intrasaccular device can comprise first and second expandable components having different shapes. Further, the first and second expandable components can have different sizes. A third expandable component can be used, which can have the same or different sizes or shapes compared to either or both of the first and second expandable components. Thus, the first, second, and third expandable components can each have a different size and/or shape compared to each other. Such principles can apply to additional components, such as fourth, fifth, sixth components, and so forth.

[0296] Further, the shapes mentioned above can be solid or at least partially hollow (e.g., having a cavity or void therewithin). Hollow expandable components can comprise braided structures (e.g., braided spheres), foam structures, and the like. A hollow expandable component can be released into the aneurysm by itself or in combination with other occlusive material, such as a liquid embolic, additional expandable components, or coils.

[0297] For example, Figures 13–15 illustrate hollow structures that can be used in accordance with embodiments of an intrasaccular device. Figures 13-15 each illustrates an intrasaccular device 150a, 150b, 150c. Each device 150a, 150b, 150c can comprise a shape having a hollow body 152a, 152b, 152c, which can in turn define a cavity 154a, 154b, 154c. The hollow body 152a, 152b, 152c can be advantageous at least because it can enable the intrasaccular devices 150a, 150b, 150c to have a more compact compressed state than a corresponding intrasaccular device (having an equivalent size when expanded) that is not hollow. Further, because the body 152a, 152b, 152c is hollow, the intrasaccular devices 150a, 150b, 150c can provide greater packing volumes within the aneurysm while using less material. Furthermore, because the intrasaccular device 150a, 150b, 150c can be compressed, comparatively, to a smaller size in its compressed state, the intrasaccular device 150a, 150b, 150c can be delivered through a smaller microcatheter.

[0298] Additionally, in some embodiments, the intrasaccular device 150a, 150b, 150c can be configured to comprise an aperture 156a, 156b, 156c in communication with the cavity 154a, 154b, 154c to permit introduction of, e.g., at least one additional expandable component, a liquid embolic, or embolic coils to further pack and/or support the aneurysm. In lieu of an aperture 156a, 156b, 156c, the clinician may perforate the intrasaccular device 150a, 150b, 150c before or during the procedure. In such a capacity or procedure, the intrasaccular device 150a, 150b, 150c can function as an intrasaccular framing device.

[0299] For example, the intrasaccular device 150a, 150b, 150c can be expanded within the aneurysm such that the intrasaccular device 150a, 150b, 150c extends across the neck of the aneurysm with the aperture 156a, 156b, 156c being accessible through the neck (see e.g., Figures 40 and 44). According to some embodiments, although the intrasaccular device extends across the neck, it may not touch or contact the neck of the aneurysm. Further, in embodiments that comprise an open end, the intrasaccular device 150a, 150b, 150c can be oriented such that the open end faces the fundus of the aneurysm and the closed end (including the aperture 156a, 156b, 156c) extends across the neck of the aneurysm.

[0300] Alternately, the aperture 156a, 156b, 156c may permit the introduction of a second smaller expandable component having a hollow interior. A third expandable component, smaller than the second expandable component, may then be introduced into the hollow interior of the second expandable component. Additional smaller foam structures may be added in a

similar manner. Figures 13, 14, and 15 illustrate spheroid, ellipsoid and prism-shaped foam structures 402, respectively.

[0301] In alternate embodiments, the intrasaccular device 150a, 150b, 150c may receive any of the aforescribed solid foam structures of the prior embodiments until the cavity 154a, 154b, 154c is packed to the desired capacity.

[0302] Figures 16–18 illustrate interlocking structures of an intrasaccular device, according to some embodiments. For example, Figures 16–17 illustrate a composite intrasaccular device 160a, 160b having first and second portions or components 162a, 162b, 164a, 164b. The first and second portions 162a, 162b, 164a, 164b can comprise respective engagement structures 166a, 166b, 168a, 168b.

[0303] The intrasaccular devices 160a, 160b shown in Figures 16–17 can be configured such that the respective engagement structures 166a, 166b, 168a, 168b provide a loose fit with each other when the first and second portions 162a, 162b, 164a, 164b are in their expanded states. However, according to some embodiments, the protrusions of the respective engagement structures 166a, 166b, 168a, 168b can be oversized relative to the recess of the respective engagement structures 166a, 166b, 168a, 168b, such that the protrusion expands to create an interference fit inside the recess, thereby securing the first portion 162a, 162b relative to the second portion 164a, 164b in the expanded states. In such embodiments, the protrusion and recess can be guided towards each other as the first and second portions 162a, 162b, 164a, 164b expand within the aneurysm. In addition to the engagement structures shown, other engagement structures can be provided, such as a ball and socket, slots, pins, etc.

[0304] Further, in embodiments having only two interconnecting portions, such interconnecting portions can be configured to restrict at least two degrees of freedom of motion of the opposing portion. Motion can be restricted in two or more of the following directions: up-and-down translation, forward and backward translation, left and right translation, side to side pivoting or rolling, left and right rotating or yawing, and forward and backwards tilting or pitching. Further, in some embodiments, such as those illustrated in Figures 16–17, at least three degrees of the freedom of motion of a portion can be restricted. For example, the interconnection between portions of such embodiments can restrict four, five, or all six degrees of freedom of motion of a given portion.

[0305] Figure 18 illustrates an intrasaccular device 180 having a plurality of interconnecting portions 182, 184, 186. These interconnecting portions 182, 184, 186 can be configured to abut each other in a complementary configuration, such as to provide a composite structure. In some embodiments, the interconnecting portions 182, 184, 186 can be configured to restrict at least two, three, four, five, or six degrees of freedom of motion of another component.

[0306] The mating expandable components, such as those embodiments illustrated in Figures 16–18 can be delivered into the aneurysm and arranged in situ such that the engagement structures are aligned and interconnected appropriately such that the expandable components are mated. In some embodiments, the mating of the expandable components can interlock the components as a composite structure or unit, as in Figure 16.

[0307] As noted above, in accordance with some embodiments, at least a portion of the intrasaccular device can comprise a coating or material for enhancing therapeutic, expansive, or imaging properties or characteristics of at least one or every expandable component of the intrasaccular device.

[0308] The intrasaccular device can be configured such that an expandable component thereof is coated with a biocompatible material to promote endothelialization or provide a therapeutic effect.

[0309] For example, Figure 19 illustrates an alternate embodiment of the present disclosure. In accordance with this embodiment, the intrasaccular device 190 comprising an expandable component 192 that can be coated and/or embedded with at least one coating 194, such as a bioactive material or agent.

[0310] The coating 194 may include thrombogenic coatings such as fibrin, fibrinogen or the like, anti-thrombogenic coatings such as heparin (and derivatives thereof), urokinase or t-PA, and endothelial promoting coatings or facilitators such as, e.g., VEGF and RGD peptide, and/or combinations thereof. Drug eluting coatings and a drug eluting foam composite, such as anti-inflammatory or antibiotic, coatings are also envisioned. These drug eluting components may include nutrients, antibiotics, anti-inflammatory agents, antiplatelet agents, anesthetic agents such as lidocaine, and anti-proliferative agents, e.g. taxol derivatives such as paclitaxel. Hydrophilic, hygroscopic, and hydrophobic materials/agents are also envisioned.

[0311] As also noted above, in some embodiments, the expandable component can also comprise an expansion-limiting coating that slows expansion of the component from its

natural rate of expansion to a slower rate of expansion such that in the process of expanding, the position of the component can be adjusted within the aneurysm or the component can be removed from the aneurysm, if necessary. Examples of polymers that can be used as expansion-limiting coatings can include hydrophobic polymers, organic non-polar polymers, PTFE, polyethylene, polyphenylene sulfide, oils, and other similar materials.

[0312] In embodiments, only specific segments of the intrasaccular device may be embedded or coated with an agent to provide desired characteristics to the expandable component(s). For example, as depicted in Figure 20, an intrasaccular device 200 can comprise a non-thrombogenic coating 202 may be applied to a lower half 204 of the expandable component 206 to minimize clotting at this location. Such coatings may be desirable in aneurysms located at a bifurcation such that blood flow to branch arteries is permitted through the segment of the foam structure having the non-thrombogenic coating. The coated area 202 may be a different color than the remaining portion of the expandable component 206 to assist the surgeon in identifying this area.

[0313] Optionally, the coated area 202 can also comprise radiopaque material to assist the surgeon in visualization and placement of the expandable component 206 in a desired orientation relative to the aneurysm. The expandable component 206 can have radiopacity characteristics either by adding radiopaque filler to the material (which in some embodiments comprises a foam material), such as bismuth, or attaching radiopaque markers. Alternatively, a radiopaque material can be attached to the expandable component 206, such as by dipping, spraying, or otherwise mechanically, chemically, or thermally attached, injected into, or blended into to the expandable component 206.

[0314] Figure 21 illustrates another embodiment of the intrasaccular devices illustrated in Figures 19–20. In Figure 21, an intrasaccular device 220 is shown that comprises has a star-shaped expandable component 222 which may be partially or fully coated and/or embedded with a material 224, such as any of the aforescribed agents. The star shape can provide increased surface area due to the presence of the undulations 226 in the outer surface of the expandable component 222.

[0315] Once the expandable component is delivered into the aneurysm, it can expand back to its full size or expanded state, confined within the neck of the aneurysm with minimal herniation within the parent vessel. The foam could be self-expandable, chemically expandable,

thermally expandable, or expandable in response to pH changes or to light. Shape memory foams such as polyurethane foam can be used.

[0316] Various delivery systems and procedures can be implemented for delivering an intrasaccular device comprising one or more expandable components, as discussed herein. Further, a system and method are provided for delivery of an intrasaccular device to an aneurysm and/or recapturing the device for removal or repositioning.

[0317] For example, in accordance with some embodiments, Figures 22–25 illustrate a delivery system and a procedure for implanting an intrasaccular device. In the illustrated embodiment, a delivery catheter 300 is advanced within a vessel 302 until a distal end 304 of the delivery catheter 300 is positioned adjacent to a target site, such as an aneurysm 306.

[0318] A carrier assembly 320 can be configured to engage an intrasaccular device 330 and deliver the intrasaccular device 330 into the aneurysm 306. The carrier assembly 320 can comprise a core member 322 and an engagement member 324. The core member 322 can be interconnected with the engagement member 324. The engagement member 324 can comprise at least two arm members 340 having a closed position (see Figure 22) and an open position (see Figure 23). In the closed position, the arm members 340 can be engaged with at least a portion of the intrasaccular device 330 to facilitate distal advancement and retention of the intrasaccular device 330 within the lumen of the catheter 300.

[0319] The carrier assembly 320, disposed within a lumen of the delivery catheter 300, can be advanced distally through the catheter 300 until reaching the distal end 304 of the catheter 300. Upon reaching the distal end 304, the carrier assembly 320 can be actuated to release an intrasaccular device 330 into the aneurysm 306, as shown in Figure 23.

[0320] The arm members 340 can be spring-loaded or configured to spring open from the closed position upon being advanced out of or distally beyond the distal end 304 of the catheter 300. However, the arm members 340 can also be manually actuated using a proximal control mechanism, thereby allowing the arm members 340 to continue engaging the intrasaccular device 330 even after the arm members 340 have moved out of the lumen of the catheter 300. For example, such a proximal control mechanism can comprise a proximally extending wire coupled to a first of the arm members 340, the proximal retraction of which causes the first arm member 342 retract into the catheter 300, thus releasing the intrasaccular

device 330. Various other control mechanisms, such as those disclosed herein, can also be implemented in accordance with some embodiments.

[0321] After the intrasaccular device 330 has been released into the aneurysm 306, the intrasaccular device 330 can begin to expand. The clinician can carefully monitor the orientation of the intrasaccular device 330 relative to the neck or surrounding the vasculature of the aneurysm 306.

[0322] According to some embodiments, if the intrasaccular device 330 has a specific characteristic, such as a porosity profile, coating, shape, etc., intended for placement in a certain location of the aneurysm 306, the clinician can position the intrasaccular device 330 by manually rotating, moving, maintaining the position of, or otherwise adjusting the position of the intrasaccular device 330 within the aneurysm 306 as the intrasaccular device 330 expands. This procedure is illustrated in Figures 24–25. Thus, by gently manipulating at least one of the arm members 340, the clinician can contact the intrasaccular device 330 to ensure proper orientation of the intrasaccular device 330 within the aneurysm 306. Although the manipulation of the position of the expandable device is shown in the context of the carrier assembly 320 in Figures 22–25, the position of the expandable device can be manipulated using various other deployment or delivery devices, such as those shown in Figures 31A–37 or Figures 61–63.

[0323] In the performance of such procedures, the intrasaccular device 330 can beneficially be coated with an expansion-limiting coating, such as those discussed above. In such embodiments, the expansion-limiting coating can allow the intrasaccular device 332 slowly expand, thus providing the clinician with a greater, and in some cases, a specified or expected period of time after releasing the intrasaccular device 330 to adjust the position of the intrasaccular device 330 within the aneurysm 306.

[0324] Figure 26 illustrates the placement of an intrasaccular device 370 within an aneurysm 306. The intrasaccular device 370 can comprise a radiopaque material 372. The radiopaque material 372 can be located at a specific end of the intrasaccular device 370 (in this case, on a first portion 374 of the intrasaccular device 370, which has a lower porosity than a second portion 376 thereof). In the illustration of Figure 26, the intrasaccular device 370 is in an intermediate expanded state (i.e., it has not yet fully expanded), and as the device 370 expands, the clinician can adjust its position based on a visualization of the radiopaque material 372. The clinician can visualize the orientation of different sections or portions of an intrasaccular device

relative to the neck or surrounding vasculature of an aneurysm, and here, align the radiopaque material 372 with the neck 380 of the aneurysm 306 (or in some embodiments, a fundus of the aneurysm 306) in order to maintain the lower porosity first portion 374 of the intrasaccular device 370 adjacent to or extending across the aneurysm neck 380.

[0325] Figures 27–30 illustrate different aneurysm configurations and surrounding vasculature that may be treated best by achieving a specific orientation of an intrasaccular device within the aneurysm.

[0326] For example, Figure 27 illustrates an intrasaccular device 390 oriented such that a low porosity section 392 thereof is positioned or extends across the neck 380 of the aneurysm 306, with a higher porosity section 396 positioned in the fundus of the aneurysm 306. Figure 27 also provides an illustration of the final result of the process described above with respect to Figures 22–25. Thus, after continued expansion, the intrasaccular device 330 shown in Figures 22–25 can achieve the position or state of expansion illustrated in Figure 27.

[0327] Figure 28 illustrates an artery 500 having an aneurysm 502 and a perforating vessel 504 extending through the aneurysm 502 adjacent to a neck 506 of the aneurysm 502. In such circumstances, an intrasaccular device 520 can be positioned within the aneurysm 502 such that a high porosity section 522 extends across the neck 506 of the aneurysm 502 in order to permit blood flow into the perforating vessel 504, as illustrated with arrows 530.

[0328] Figure 29 illustrates an artery 550 having an aneurysm 552 and a perforating vessel 554 extending from the fundus of the aneurysm 552. In such situations, an intrasaccular device 560 can be positioned within the aneurysm 552 such that a first, high porosity section or channel 562 of the intrasaccular device 560 provides a fluid pathway for blood to flow through the neck 564 of the aneurysm 552 toward and into the perforator vessel 554, as shown by arrow 570. Additionally, the intrasaccular device 560 can be configured to comprise one or more low porosity sections 572, 574 that can tend to induce thrombosis and protect the aneurysm wall.

[0329] Figure 30 illustrates an intrasaccular device 590 oriented such that a low porosity section 592 thereof is positioned or extends across the neck 594 of an aneurysm 596 located at a vessel bifurcation. As illustrated, a higher porosity section 598 can be positioned in the fundus of the aneurysm 596. Thus, flow through the bifurcation, as shown by arrows 600 can be diverted using the low porosity section 592, thereby relieving pressure on the aneurysm 596.

[0330] Referring now to Figures 31A–34, engagement mechanisms for a delivery and recapture system, as shown in Figure 22, are provided. These engagement mechanisms can provide secure engagement and release of one or more expandable components. Further, the system can recapture the device for removal or repositioning.

[0331] As discussed above with respect to the engagement mechanism of Figure 22, the engagement mechanisms illustrated in Figures 31A–34 can move between closed and open positions in order to facilitate engagement with and delivery of an intrasaccular device into an aneurysm.

[0332] Figures 31A–31B illustrate a system and method for delivery an intrasaccular device to an aneurysm and/or recapturing the device for removal or repositioning. In one embodiment, the delivery system may include an introducer catheter or sheath 630. A delivery/retrieval member 680 can be disposed within a lumen of the catheter 630. The delivery/retrieval member 680 may include an elongated element 682 having a plurality of gripping elements 684 at one end. The delivery/retrieval member 680 can be dimensioned to traverse the longitudinal lumen of the introducer sheath 630. The gripping elements 684 can be adapted to open and close about the intrasaccular device 650. In some embodiments, the gripping elements 684 can be normally biased to an open position.

[0333] In some embodiments, the delivery/retrieval member 680 can comprise the Alligator Retrieval Device, manufactured by Covidien LP, generally represented in Figures 31A–31B. The Alligator Retrieval Device can include a flexible wire having a plurality of gripping arms or elements, e.g., four arms, at the distal end of the flexible wire. Other embodiments for the gripping elements 58 include a clover leaf design, fish hook design, or dissolvable coupling, as shown in Figures 31A–34, respectively.

[0334] In use, an access catheter is advanced within the neurovasculature as is conventional in the art. A suitable microcatheter adaptable for navigation through the tortuous neurovascular space to access the treatment site is disclosed in commonly assigned U.S. Patent No. 7,507,229, the entire contents of which are hereby incorporated herein.

[0335] The gripping elements 684 of the delivery/retrieval member 680 are positioned about the intrasaccular device 650 (Figure 31A), and the delivery/retrieval member 680 is withdrawn into the introducer sheath 630 such that the gripping elements 684 move inwardly during engagement with the inner wall surface of the introducer sheath 630 to compress

the foam structure of the intrasaccular device 650 as depicted in Figure 31B. The intrasaccular device 650 is withdrawn into the introducer sheath 630. The introducer sheath 630 with the delivery/retrieval member 682 and intrasaccular device 650 positioned therein is advanced through the access catheter accessing the aneurysm. The access catheter may be removed if desired, or may be left in place. Thereafter, the introducer sheath 630 is oriented at the desired orientation with respect to the aneurysm. Any of the engagement devices illustrated herein can be used for both delivery and retrieval of expandable components.

[0336] The delivery/retrieval member 682 is advanced through the introducer sheath 630 whereby upon clearing the distal end of the introducer sheath 630 the gripping elements 684 of the delivery/retrieval member 682 open to release the intrasaccular device 650. In the event the intrasaccular device 650 is not properly positioned within the aneurysm or is dislodged, the gripping elements 684, in the open configuration, and extended beyond the introducer sheath 630, are positioned to circumscribe the intrasaccular device 650 within the vasculature. The delivery/retrieval member 682 is withdrawn into the introducer sheath 630 whereby the gripping elements 684 compress the foam material of the intrasaccular device 650 to permit reception of the device 650 within the lumen of the introducer sheath 630. Thereafter, the intrasaccular device 650 can be removed from the neurovasculature or repositioned within the aneurysm by deployment of the delivery/retrieval member 682 in the manner discussed herein.

[0337] Figures 32A–32B similarly illustrate an engagement mechanism 620 in the form of a “clover” pattern. The engagement mechanism 620 can be disposed within a catheter 630 and advanced distally until exiting the lumen of the catheter 630 at the distal end 632. Upon exiting, wire loops 640 of the engagement mechanism 620 can be released from engaging the intrasaccular device 650. As illustrated in Figure 31B, when released, the intrasaccular device 650 may not tend to snag or stick to the wire loops 640. Accordingly, the engagement mechanism 620 can provide fast and reliable disengagement with the intrasaccular device 650.

[0338] Figures 33A–33B illustrate another embodiment of an engagement mechanism 670 having a “fish hook” design, similar to the engagement mechanisms 324, 620 can move between closed and open positions upon exiting a distal end 632 of the catheter 630 the engagement mechanism 670 can comprise a plurality of hooks 672 configured to pierce or otherwise at least partially penetrate the intrasaccular device 650. Upon release, the hooks 672

can disengage from the intrasaccular device 650 in order to release the intrasaccular device 650 into the aneurysm.

[0339] Figure 34 illustrates an embodiment of a system in which a delivery member 690 is attached to an intrasaccular device 650 using a dissolvable coupling 692. The dissolvable coupling 692 can extend between the intrasaccular device 650 and an aperture or engagement member of the delivery member 690. In accordance with some embodiments, engagement member of the delivery member 690 can engage the dissolvable coupling 692 using a hook, wire loop, or other elongate member, such as those disclosed in other delivery systems above. The dissolvable coupling 692 can be actuated by chemical corrosion (e.g., electrolytic detachment), thermal corrosion, pH changes, light changes, etc. Further, the releasable connection 692 may be effected through an electrical, hydraulic or pneumatic connection where release of the intrasaccular device 650 is achieved through activation of any of these systems. For example, once the intrasaccular device 650 is positioned within the aneurysm, any of the aforementioned means may be actuated to release the intrasaccular device 650 from the delivery member 690.

[0340] Figure 35 illustrates a microcatheter delivery system for implanting an intrasaccular device 720 within the aneurysm. A delivery system 730 can comprise a delivery catheter 732 and pusher element 734 disposed within the delivery catheter 732. The intrasaccular device 720 in its normal configuration and predetermined geometry can be compressed and positioned within the lumen of the delivery catheter 732.

[0341] The delivery catheter 732 may be introduced within the neurovasculature and advanced to the treatment site. Once appropriately oriented with respect to the aneurysm, the pusher element 734 is actuated by, e.g., advancing a handle or actuator operatively connected to the proximal end of the pusher element 734 to cause the distal or remote end of the pusher element 734 to eject the intrasaccular device 720. The intrasaccular device 720 can expand to pack the aneurysm.

[0342] Additionally, in accordance with some embodiments, the pusher element 734 can comprise a radiopaque material or component 736 disposed on a contact member 738 of the pusher element 734. As the pusher element 734 is advanced within the lumen of the catheter 732, the radiopaque material 736 can enable the clinician to visualize the location of the intrasaccular device 720 to ensure proper positioning of the pusher element 734 within the lumen of the catheter 732.

[0343] Figure 36 illustrates an alternate embodiment of the delivery system. In accordance with this embodiment, system 760 includes introducer sheath 762 and delivery member 764 disposed within the introducer sheath 762. The delivery member 764 may be a push rod advanceable within the introducer sheath 762. The intrasaccular device of this disclosure includes a plurality of intrasaccular pellets 770a, 770b disposed within the introducer sheath 762 to be ejected in sequence via the delivery member 764. For example, the plurality of pellets can comprise a framing shape, which has been compressed and folded as a framing pellet 770a. The pellet 770a will be the last pellet to enter the aneurysm (after pellets 770b). Thus, the framing pellet 770a can tend to expand so as to extend across a neck of the aneurysm (although not necessarily touching the ostium of the aneurysm).

[0344] These intrasaccular devices or pellets 770a, 770b may be smaller in dimension than the aforescribed intrasaccular devices to enable multiple and strategic deployment within the aneurysm. Any of the embodiments of the aforescribed intrasaccular devices may be incorporated within the pellets 770a, 770B. Further, the delivery member 764 can incorporate one or more radiopaque materials or components 772 to facilitate visualization of the location of the delivery member 764 within the sheath 762.

[0345] Figure 37 illustrates another delivery system 790, in accordance with some embodiments. The delivery system 790 can comprise an over-the-wire system having a guide member 792 comprising a guide wire lumen 794. The guide member 792 can also comprise a delivery lumen 796 in which a push rod 798 can be disposed for axial movement therewithin in order to deliver an intrasaccular device comprising a plurality of expandable components 800. Such an embodiment can allow the system 790 to define a minimal cross-sectional profile, thereby allowing the system 790 to extend into and through very narrow vessels to treat aneurysms in smaller vessels.

[0346] Figures 38–42 illustrate various implementations of some of the embodiments disclosed herein. For example, Figure 38 illustrates an intrasaccular component 820 that has been implanted into an aneurysm 830. As shown, the intrasaccular component 820 comprises a shape that is substantially an octahedron. Such a shape can be beneficial for securely anchoring the intrasaccular component 820 within the aneurysm 830 given the expanding waist and tapering ends that permit the intrasaccular component 820 to fit well within a berry or saccular aneurysm.

In addition, the intrasaccular component 820 also comprises a radiopaque material or marker 822 for use in locating and positioning the intrasaccular component 820 within the aneurysm 830.

[0347] Figure 39 illustrates an intrasaccular device 840 positioned within an aneurysm 830. The intrasaccular device 840 comprises first and second expandable components 842, 844. The first expandable component 842 comprises a shape that is substantially conical or a paraboloid of revolution. The second expandable component 844 comprises a shape that is substantially hemispherical. The first and second expandable components 842, 844 can comprise respective first and second mating surface 852, 854.

[0348] When initially inserted into the aneurysm, prior to expansion, both the first and second expandable components 842, 844 easily fit into the aneurysm 830. Upon expansion, neither the first nor second expandable components 842, 844 entirely packs the aneurysm 830. Thus, if either of the first or second expandable components 842, 844 were positioned by itself in the aneurysm 830, significant movement and potential herniation of the respective component could occur from within the aneurysm 830. However, as the first and second expandable components 842, 844 expand within the aneurysm 830, the first and second mating surfaces 852, 854 can cause the first and second expandable components 842, 844 to become aligned within the aneurysm 830. Such alignment, as illustrated in Figure 39, can tend to prevent dislocation of either the first or second expandable components 842, 844, thus securing the intrasaccular device 840 within the aneurysm 830.

[0349] According to some embodiments, an intrasaccular the first and second mating surfaces 852, 854 can be substantially flat. However, as illustrated in Figure 40, some embodiments can be configured such that an intrasaccular device 860, positioned within an aneurysm 830, comprises first and second mating surfaces 870, 872 of first and second expandable components 880, 882 can comprise an engagement mechanism 884. The engagement mechanism 884 can comprise engagement structures, such as a recess and a corresponding protrusion, as illustrated. The engagement mechanism 884 can comprise one of a variety of structures, such as one or more recesses and one or more corresponding protrusions, including hemispherical, cylindrical, conical, or other such geometric mating recesses and protrusions. Accordingly, the engagement mechanism 84 can tend to prevent slippage between the first and second mating surfaces 870, 872, thus tending to cause the first and second expandable components 880, 882 to function as a composite unit.

[0350] As noted above with respect to Figures 13–15, some embodiments of the intrasaccular device can comprise a hollow component that can be implanted into an aneurysm. Although a plurality of hollow components can be implanted into the aneurysm as a system, a single hollow component can also be set in place and later packed with one or more expandable components. Thus, the hollow component can act as a support or framing structure having an enclosed cavity configured to receive additional components therein.

[0351] For example, Figure 41 illustrates an intrasaccular device 900 in the form of a hollow expandable component 902 that is implanted into an aneurysm 904 along with a plurality of expandable components 906. As shown, the hollow component 902 can be in the form of a hollow hemispherical shell that can act as a support or framing structure for the aneurysm and additional expandable components placed therein. The hollow component 902 can have an outer surface 908 that is in contact against an inner wall 912 of the aneurysm 904. As illustrated, the contact between the outer surface 908 and the aneurysm wall 912 can be along a portion of the aneurysm wall 912 that has a cross-sectional profile greater than the size of the opening or passing profile of the neck 920 of the aneurysm 904. Further, contact between the outer surface 908 and the aneurysm wall 912 can be at least along the lower half of the aneurysm 904.

[0352] In some embodiments, the outer surface 908 of the hollow component 902 can contact against a first section of the aneurysm wall 912 adjacent to the aneurysm neck 920, as well as against a second section of the aneurysm wall 912 adjacent to the aneurysm dome 918, opposite the aneurysm neck 920. For example, the aneurysm 904 or aneurysm wall 912 can be considered in terms of quadrants, and the outer surface 908 can contact at least three quadrants of the aneurysm wall 912. In some embodiments, the outer surface 908 can be caused to contact at least a portion of each quadrant of the aneurysm wall 912. The contact of the outer surface 908 against the aneurysm wall 912 can tend to secure the hollow component 902 within the aneurysm 904 to avoid dislocation or herniation of any portion of the hollow component 902 from the aneurysm 904.

[0353] Referring still to Figure 41, the expandable components 906 can be inserted or injected into a cavity of the hollow component 902 through an aperture 910 formed in a sidewall of the hollow component 902. The aperture 910 can be sized such that the expandable components 906 can be inserted through the aperture 910 in their compressed state, but upon expansion, the expandable components 906 will be unable to exit through the aperture 910. As

also illustrated, the expandable components 906 can position themselves during expansion such that irregular shapes of the dome 918 of the aneurysm 904 can be packed. Additionally, the intrasaccular device 900 can provide a lower porosity adjacent to the neck 920 of the aneurysm 904 while having a relatively higher porosity adjacent to the dome 918.

[0354] In accordance with some embodiments, the support or framing component can comprise a stent that extends along a lumen adjacent to an aneurysm. The aneurysm can be a saccular or berry, wide neck, or fusiform aneurysm. For example, a stent can be used in combination with any of the variety of intrasaccular devices illustrated above, such as those shown in Figures 22–30 and 38–41, which are shown as treating saccular aneurysms. In some embodiments, the framing component can advantageously secure the intrasaccular device within a wide-neck aneurysm by facilitating engagement with a sufficient amount of the aneurysm wall to avoid dislodgement or herniation of the device from the aneurysm into the parent vessel.

[0355] Figure 42 illustrates an implementation of an intrasaccular device 940 in a method for treating a fusiform aneurysm 950. As illustrated, the intrasaccular device 940 can comprise a stent 952 that extends across the aneurysm 950. The stent 952 can be released at the target location using a catheter and any of a variety of release methods, such as balloon expansion or self-expansion.

[0356] When expanded into contact against the inner wall of the lumen 954, the stent 952 can isolate, separate, or divide the inner cavity 956 of the fusiform aneurysm 950 from a central portion of the lumen 954.

[0357] When the stent 952 is in place, at least one expandable component 960 can be released into the inner cavity 956 between the inner wall of the aneurysm 950 and an outer surface 962 of the stent 952. The expandable component(s) 960 can be inserted into the cavity 956 through an opening in a wall of the stent 952 (or if the stent 952 is braided, through an interstice of the braid).

[0358] As discussed herein, the expandable component(s) 960 can have one or more characteristics that improve the effectiveness of the intrasaccular device 940. Further, the characteristics of the expandable component 960 can be selected based on the shape or configuration of the aneurysm 950, as discussed above. As shown in Figure 42, the expandable components can have a specific shape to pack the cavity 956 (e.g., a sectioned sphere with a luminal void extending through the sections, thus providing a flatter cylindrically shaped surface

that can abut the outer surface of the stent 952). However, any of a variety of other shapes can also be selected and inserted into the cavity 956.

[0359] In accordance with some embodiments, after an intrasaccular device has been implanted into an aneurysm, a material such as a liquid embolic (as discussed above), a drug, a radiopaque material, a contrast agent, or other agent can be injected or inserted into the aneurysm. The injection or insertion can occur prior to, concurrently with, or after expansion of the intrasaccular device within the aneurysm. As such, the material can be absorbed into at least a portion of the intrasaccular device or pack any remaining voids within the aneurysm around the intrasaccular device. The injection of a liquid embolic can advantageously increase the overall packing density of the device. Figures 43 and 44 illustrate embodiments in which a liquid embolic is inserted into the aneurysm in combination with an intrasaccular device.

[0360] For example, Figure 43 illustrates that a material 980 (e.g., a liquid embolic, drug, radiopaque material, contrast agent, or other agent) is being inserted into an aneurysm 982 along with an intrasaccular device 984. The intrasaccular device 984 can have a high porosity, which can allow the material 980 to penetrate the intrasaccular device 984.

[0361] Figure 44 illustrates injection of a material 990 into an aneurysm 992. As shown, the material 990 can flow into the aneurysm 982 into the interstice is formed between expandable components of the intrasaccular device 994. In such an embodiment, the components of the intrasaccular device 994 can have a lower porosity such that the material 998 may not tend to penetrate the components of the intrasaccular device 994 as much as in the embodiment illustrated in Figure 43.

[0362] Thus, various materials can be injected or inserted into the aneurysm to supplement or complement the treatment provided by an intrasaccular device.

[0363] Figures 45–52 illustrate additional embodiments of an intrasaccular device that uses a support or framing component or structure in combination with secondary expandable components.

[0364] Figures 45–46 illustrates an embodiment in which an aneurysm 1000 is treated using an intrasaccular device 1100a, which comprises a framing structure 1102a having a closed end 1104 and an open end 1106. In some embodiments, the framing structure 1102a can be formed from a braided material.

[0365] In one embodiment, the closed end 1104 of the framing structure is sealed via a clamp 1108, an adhesive, or may be heat welded via known techniques. The closed end 1104 may be inverted relative to the remaining framing structure 1102a and depend inwardly within the interior thereof. The open end 1106 of the framing structure 1102a may be in diametrical opposed relation to the closed end 1104. The individual filaments ends 1110 of the framing structure at the open end 1106 also may be inverted and disposed within the interior of the framing structure 1102a.

[0366] Figure 45 depicts the introduction of the coils through the open end 1106 of the framing structure 1102a. Suitable braid materials, structures, and method for manufacturing the framing structure 1102a are disclosed in commonly assigned U.S. Patent No. 6,168,622 to Mazzocchi, U.S. Patent No. 8,142,456, issued March 27, 2012, U.S. Patent Application Publication No. 2011/0319926, filed on November 11, 2010, and U.S. Patent Application Publication No. 2012/0330341, filed on June 22, 2011, the entireties of each of which are incorporated herein by reference. Braid materials may include stainless steel, nitinol cobalt chromium or the like.

[0367] As shown in the embodiment of Figures 45–46, the framing structure 1102a can be deployed in the aneurysm 1000 and packed with coils 1120. However, as shown in Figure 47–49, an intrasaccular device 1100b, 1100c, 1100d can comprise a framing structure 1102b, 1150, 1160 that can be packed with at least one expandable component 1130, 1140 (e.g., a foam component). The configuration, selection, and use of the expandable components 1130, 1140 are discussed above and will not be repeated here for brevity. However, any of the embodiments disclosed herein can be used in conjunction with the framing structure 1102a. Further, in embodiments using an expandable component, such as a foam component, the foam can advantageously provide a higher packing density compared to traditional coil packing and accomplish this in a single device.

[0368] The framing structure 1102a, combined with coils, an expandable component, or other materials, can also provide the benefit of providing good neck coverage while preventing embolic devices from herniating into the parent artery. Additionally, the use of such a system can also increase packing volume efficiency and achieve stasis.

[0369] As illustrated, the framing structure 1102a may provide a support or scaffold for the supplemental intrasaccular components or materials, including coils, expandable

components, or other materials (e.g., a liquid embolic, drug, radiopaque material, contrast agent, or other agent). The coils 1120 or expandable component 1130 may contain or be coated with bioactive coating that promotes specific clinical therapy such as endothelialization, thrombosis, etc.

[0370] Referring briefly to Figures 50–52, these figures illustrate examples of framing structures that can be used as support or framing components, according to some embodiments. In Figure 50, a braided device 1200 can comprise a single-layer outer portion 1202 that is formed by inverting a tubular braid such that an inner portion 1204 of the braid extends through a center portion of the device 1200. Ends of the inner and outer portions 1202, 1204 meet at a first end 1206. Although the filament ends of the inner and outer portions 1202, 1204 can remain free (as tufts) or unbundled, the first end 1206 can comprise a hub or coupling device 1208 that bundles the inner and outer portions 1202, 1204 together. In some embodiments, the hub or coupling device 1208 can be recessed within an interior of the device 1200, although it is shown protruding in Figure 50.

[0371] Figure 51 illustrates another embodiment of a framing structure in which a braided device 1230 comprises at least one layer 1232 extending around the periphery of the device 1230. In some embodiments, a single layer can be used, but multiple braided layers are also possible. The device 1230 can comprise first and second ends 1234, 1236 that can be inverted or recessed into the device 1232 formed a smooth outer surface for the device 1230. The first and second ends 134, 136 can be open or closed. As shown, the first and second ends 1234, 1236 can comprise coupling devices 1240, 1242, which close both ends 1234, 1236. However, one or both of the first and second ends 1234, 1236 can also be open, such that the filament ends thereof are free and unbundled.

[0372] Figure 52 illustrates yet another embodiment of the framing structure in which a braided device 1250 comprises a dual layer shell 1252 having a substantially closed end 1254 and an open end 1256. The open end 1256 can be inverted or recessed into the device 1250.

[0373] Referring again to Figures 45–46 and 48–49, after a framing structure 1102a, 1150, 1160 has been released and expanded into contact against an inner wall of the aneurysm 1000, the procedure of implanting coils, an expandable component, or other materials into the framing structure 1102a, 1150, 1160 can be performed by either inserting a catheter 1112, such

as a distal end 1114 thereof, between filaments of the framing structure (see Figure 48) or into an open end of the framing structure (see Figures 45 and 49).

[0374] In implementing a method for placing a framing structure within an aneurysm and injecting coils, expandable component(s), or other materials into the framing structure, the open end or widest interstices of the framing structure can be positioned at the neck of the aneurysm so as to facilitate insertion of the distal end 1114 of the catheter 1112 into the open end or between the filaments (i.e., into an interstice) of the framing structure. In embodiments having a braided material for the framing structure, the braid pattern can be properly aligned to facilitate entry of the materials into the framing structure. As in other embodiments disclosed herein, the framing structure can comprise a radiopaque material or component that facilitates visualization and enables the clinician to align the framing structure as needed within the aneurysm.

[0375] As illustrated in Figures 46–47 and 49, after the coils, expandable component, or other materials have been inserted into the interior of the braided device through its open end, the open end can collapse onto itself or onto an inner surface of the framing structure as the coils, expandable component, or other materials settle or expand within the cavity of the framing structure. As shown in Figure 49, the distal end 1114 of the catheter 1112 can be withdrawn, thus allowing the open tube portion 1162 to close onto itself in response to expansive forces from the expanding component(s) or materials. Further, in some embodiments, as illustrated in Figure 52, an open end 1256 can define a generally tubular portion that can be deflected into contact with the inner wall of the framing structure when at least one expandable component is released into and expand within the cavity of the framing structure. As such, the open end can tend to self-seal, thus preventing herniation of the coils, expandable component, or other materials disposed within the framing structure.

[0376] The composite effect of the coils, expandable component, and/or other materials inserted into the framing structure can provide the advantages and benefits discussed above with respect to various other expandable components. As such, the clinician can determine and control various intrasaccular implant characteristics, including porosity, composition, material, shape, size, interconnectedness, inter-engagement, coating, etc.

[0377] According to some embodiments, systems or kits having a framing structure and at least one coil, expandable component, and/or other material can be provided.

[0378] Intrasaccular implant devices and procedures for treating aneurysms can be improved by interconnecting individual components of the intrasaccular device. According to some embodiments, a plurality of expandable components can be interconnected along a wire, filament, or other disconnectable or breakable material. The expandable components can be connected in a linear configuration (see Figures 53-58C), a planar matrix (see Figures 59A-60B), or in a three-dimensional matrix (see Figures 61A-61B). The expandable components of such interconnected linear, planar, or three-dimensional matrices can be sized and configured in accordance with desired porosity, size, shape, radiopacity, or other characteristics disclosed herein, which will not be repeated here for brevity.

[0379] In some embodiments, methods are provided by which interconnected expandable components can be released into an aneurysm. The interconnected components can be preconfigured (e.g., a select number of components can be removed from a larger strand or array of components) prior to implantation and later inserted into a delivery catheter. Thereafter, the entire strand or assembly of interconnected expandable components of the intrasaccular device can be released into the aneurysm.

[0380] However, in accordance with some embodiments, an entire strand or array of components (which would, in their expanded state, exceed the available space in the aneurysm) can be loaded into a delivery catheter, and while implanting and observing the packing behavior, a clinician can determine that a select portion of the interconnected expandable components is sufficient for a given aneurysm. Thereafter, the select portion of the interconnected expandable components can be broken or cut in situ so as to be released into the aneurysm.

[0381] Referring now to Figures 53-57C, various embodiments of linearly interconnected expandable components are shown. As illustrated in these figures, an intrasaccular device 1300a, 1300b, 1300c, 1300d can comprise a strip of expandable components 1302a, 1302b, 1302c, 1302d. The strip 1302a, 1302b, 1302c, 1302d may include spaces or breaks separating adjacent expandable components to facilitate selective detachment of expandable components. The configuration of the strip 1302a, 1302b, 1302c, 1302d permits the clinician to either detach a desired number of expandable components needed for the procedure before initiating the procedure or detaching a desired number of components in situ. Intrasaccular devices having interconnected expandable components can be delivered with or without a supporting or framing structure.

[0382] The expandable components 1302a, 1302b, 1302c, 1302d may be interconnected along one or more strings, filaments, carriers, indentations, reduced size sections, or perforation lines (which may include or be devoid of a filament or string) 1304a, 1304b, 1304c, 1304d. For example, Figure 53 illustrates an intrasaccular device 1300a having a plurality of indentations or 1304a (which can also include or be substituted by perforation lines) that separate adjacent expandable components. Figure 54 illustrates an intrasaccular device 1300b having a plurality of expandable components that are formed or molded along a filament or string 1304b. Further, Figures 55–56 can include filaments or reduced diameter expandable portions 1304c, 1304d that interconnect adjacent expandable components.

[0383] In accordance with some embodiments, the strings, filaments, carriers, indentations, reduced size sections, or perforation lines extending between adjacent expandable components can enhance pushability of the intrasaccular device 1300a, 1300b, 1300c, 1300d into the aneurysm.

[0384] Further, as illustrated in Figures 57A–57C, the expandable components of the intrasaccular device 1300a, 1300b, 1300c, 1300d can comprise one or more cross-sectional profiles, such as a rectangle shape 1320 (see Figure 57A), a square shape 1330 (see Figure 57B), or a round, e.g., circular, shape 1340 (see Figure 57C). Various other cross-sectional profiles can be provided, such as polygons having three, five, six, seven or eight sides, star shapes, clover shapes, and the like. Additionally, a single intrasaccular device can comprise expandable components that have different cross-sectional shapes or that have identical cross-sectional shapes, according to some embodiments.

[0385] Further, in accordance with some embodiments, consecutive expandable components of an intrasaccular device 1300a, 1300b, 1300c, 1300d can descend in size, which can allow selection of a subset of the expandable components of the intrasaccular device 1300a, 1300b, 1300c, 1300d based on a specific target aneurysm size or shape.

[0386] Figures 58A–60B illustrate additional embodiments of intrasaccular devices that can have nonlinear configurations. For example, Figure 58A illustrates an embodiment of an intrasaccular device 1400 comprising a layer or planar array of a plurality of interconnected expandable components 1402 in a compressed state, according to some embodiments. The expandable components 1402 can be interconnected by one or more strings, filaments, carriers, indentations, reduced size sections, or perforation lines (which may include or be devoid of a

filament or string) 1406. The expandable components 1402 can have the same or different shapes, sizes, or material properties as each other. For example, as illustrated in Figures 58A–58B, the intrasaccular device 1400 can comprise a central expandable component 1404 having an expanded size that is much greater than the expanded sizes of surrounding expandable components 1402. Thus, as shown in Figure 58B, when released into an aneurysm, the intrasaccular device 1400 can expand into a configuration in which the central component 1404 is anchored in the aneurysm 1420 by the surrounding expandable components 1402.

[0387] Similar to the embodiment illustrated in Figures 58A–58B, various embodiments can be provided in which surrounding or anchoring expandable components can be interconnected with other components in a matrix to enhance the fit or engagement of the intrasaccular device within an aneurysm. Further, such surrounding expandable components can have characteristics different from those of the central expandable component, such as having coatings or other properties that beneficially affect the efficacy of the intrasaccular device within the aneurysm.

[0388] Figure 59A–59B illustrate embodiments of intrasaccular devices 1450, 1460 comprising a layer, ring, or planar array of interconnected expandable components 1452, 1462 in a compressed state. The expandable components 1452, 1462 can be interconnected by one or more strings, filaments, carriers, indentations, reduced size sections, or perforation lines (which may include or be devoid of a filament or string) 1454, 1464. For example, each of the expandable components 1452, 1462 can be connected to at least two other expandable components 1452, 1462.

[0389] Figure 60A–60B illustrate embodiments of intrasaccular devices 1480, 1490 comprising a three-dimensional or multi-planar array of interconnected expandable components 1482, 1492 in a compressed state. The expandable components 1482, 1492 can be interconnected by one or more strings, filaments, carriers, indentations, reduced size sections, or perforation lines (which may include or be devoid of a filament or string) 1484, 1494. For example, each of the expandable components 1482, 1492 can be connected to at least two other expandable components 1482, 1492 to create a three-dimensional array. Similar to the layer or planar array shown in Figures 58A–59B, a three-dimensional array can have expandable components that each have characteristics different from those of other components, such as having coatings or

other properties that beneficially affect the efficacy of the intrasaccular device within the aneurysm.

[0390] The advantageous features of intrasaccular devices having strip configurations can allow a clinician to quickly and readily assess a target aneurysm and tailor an intrasaccular device specifically for the procedure. The customization of an intrasaccular device strip can be done before implantation or in situ. Further, the interconnectedness of the components tends to ensure that no component is lost.

[0391] Figures 61–63 illustrate a delivery system and procedure for delivering a strip of interconnected expandable components, according to some embodiments. As discussed, the configuration of the strip 1302a, 1302b, 1302c, 1302d permits the clinician to detach a desired number of expandable components needed for the procedure.

[0392] Prior to initiating the implantation of an strip of interconnected intrasaccular device, a clinician, through imaging means, can determine the size and dimension of an aneurysm 1500. Once the dimensioning is determined, the clinician can determine decide upon a configuration for the intrasaccular device or strip 1502 of interconnected expandable components to be implanted. As shown in Figure 61, the strip 1502 can be delivered using an implant delivery assembly 1504, which can comprise a catheter 1506 and a pusher component 1508.

[0393] In some embodiments of the delivery procedure, after determining the configuration for the strip 1502, the clinician can prepare the strip 1502 by separating any unnecessary expandable components there from prior to inserting the strip 1502 into the delivery assembly 1504. Thereafter, the strip 1502 is then introduced within the aneurysm in accordance with any of the aforescribed methodologies.

[0394] However, in some embodiments of the delivery procedure, the clinician can load a strip 1502 into the catheter 1506 before trimming any expandable components from the strip 1502. The clinician can then push the strip 1502 out through a distal end 1510 of the catheter 1506, which causes the individual expandable components 1520 to begin to expand within the aneurysm 1500. As the expansion is taking place, the clinician can determine whether additional expandable components 1520 should be deployed into the aneurysm 1500. If needed, the pusher component 1508 can be moved distally to urge one or more additional expandable components 1520 out of the catheter 1506. When it is determined that a sufficient number of expandable components 1520 are inserted into the aneurysm 1500, the clinician can break or

separate the strip 1502 by separating the respective expandable components 1520 via trimming or tearing along the breaks, indentations or score lines and separating the expandable components 1520.

[0395] The breaking or separating of adjacent expandable components can be performed by actuating the cutting device 1540. In some embodiments, the cutting device 1540 can comprise a second catheter 1542 that is nested within the catheter 1506. The second catheter 1542 can comprise a distal portion 1544 having an opening 1546 that extends from a side of the second catheter 1542. The distal portion 1544 can have a rounded shape that can guide the expandable components 1520 out through the opening 1546. In order to trim the strip 1502, the second catheter 1542 can be retracted proximally relative to the catheter 1506, thus causing the opening 1546 to close against the distal end 1510 of the catheter 1506, thereby severing a tie or filament extending between adjacent expandable components 1520.

[0396] Thereafter, the distal portion 1544 of the second catheter 1542 can be further withdrawn into the catheter 1506 and the delivery assembly 1504 can be removed from the target site.

[0397] Many of the features discussed herein can be used with any of the disclosed embodiments. For example, any of the embodiments can comprise an average porosity that varies spatially, any of the variety of disclosed shapes, any of the various disclosed materials or coatings, any of the disclosed 2-D or 3-D interconnected configurations, any of the disclosed inter-engagement configurations or structures, any of the disclosed delivery systems, etc.

[0398] The apparatus and methods discussed herein are not limited to the deployment and use of a medical device or stent within the vascular system but may include any number of further treatment applications. Other treatment sites may include areas or regions of the body including any hollow anatomical structures.

[0399] The foregoing description is provided to enable a person skilled in the art to practice the various configurations described herein. While the subject technology has been particularly described with reference to the various figures and configurations, it should be understood that these are for illustration purposes only and should not be taken as limiting the scope of the subject technology.

[0400] There may be many other ways to implement the subject technology. Various functions and elements described herein may be partitioned differently from those shown without

departing from the scope of the subject technology. Various modifications to these configurations will be readily apparent to those skilled in the art, and generic principles defined herein may be applied to other configurations. Thus, many changes and modifications may be made to the subject technology, by one having ordinary skill in the art, without departing from the scope of the subject technology.

[0401] It is understood that the specific order or hierarchy of steps in the processes disclosed is an illustration of exemplary approaches. Based upon design preferences, it is understood that the specific order or hierarchy of steps in the processes may be rearranged. Some of the steps may be performed simultaneously. The accompanying method claims present elements of the various steps in a sample order, and are not meant to be limited to the specific order or hierarchy presented.

[0402] As used herein, the phrase “at least one of” preceding a series of items, with the term “and” or “or” to separate any of the items, modifies the list as a whole, rather than each member of the list (i.e., each item). The phrase “at least one of” does not require selection of at least one of each item listed; rather, the phrase allows a meaning that includes at least one of any one of the items, and/or at least one of any combination of the items, and/or at least one of each of the items. By way of example, the phrases “at least one of A, B, and C” or “at least one of A, B, or C” each refer to only A, only B, or only C; any combination of A, B, and C; and/or at least one of each of A, B, and C.

[0403] Terms such as “top,” “bottom,” “front,” “rear” and the like as used in this disclosure should be understood as referring to an arbitrary frame of reference, rather than to the ordinary gravitational frame of reference. Thus, a top surface, a bottom surface, a front surface, and a rear surface may extend upwardly, downwardly, diagonally, or horizontally in a gravitational frame of reference.

[0404] Furthermore, to the extent that the term “include,” “have,” or the like is used in the description or the claims, such term is intended to be inclusive in a manner similar to the term “comprise” as “comprise” is interpreted when employed as a transitional word in a claim.

[0405] The word “exemplary” is used herein to mean “serving as an example, instance, or illustration.” Any embodiment described herein as “exemplary” is not necessarily to be construed as preferred or advantageous over other embodiments.

[0406] A reference to an element in the singular is not intended to mean “one and only one” unless specifically stated, but rather “one or more.” Pronouns in the masculine (e.g., his) include the feminine and neuter gender (e.g., her and its) and vice versa. The term “some” refers to one or more. Underlined and/or italicized headings and subheadings are used for convenience only, do not limit the subject technology, and are not referred to in connection with the interpretation of the description of the subject technology. All structural and functional equivalents to the elements of the various configurations described throughout this disclosure that are known or later come to be known to those of ordinary skill in the art are expressly incorporated herein by reference and intended to be encompassed by the subject technology. Moreover, nothing disclosed herein is intended to be dedicated to the public regardless of whether such disclosure is explicitly recited in the above description.

[0407] Although the detailed description contains many specifics, these should not be construed as limiting the scope of the subject technology but merely as illustrating different examples and aspects of the subject technology. It should be appreciated that the scope of the subject technology includes other embodiments not discussed in detail above. Various other modifications, changes and variations may be made in the arrangement, operation and details of the method and apparatus of the subject technology disclosed herein without departing from the scope of the present disclosure. Unless otherwise expressed, reference to an element in the singular is not intended to mean “one and only one” unless explicitly stated, but rather is meant to mean “one or more.” In addition, it is not necessary for a device or method to address every problem that is solvable (or possess every advantage that is achievable) by different embodiments of the disclosure in order to be encompassed within the scope of the disclosure. The use herein of “can” and derivatives thereof shall be understood in the sense of “possibly” or “optionally” as opposed to an affirmative capability.

WHAT IS CLAIMED IS:

1. A device for treatment of an aneurysm, comprising:
a foam component having first and second sections, the first section having an average porosity different from an average porosity of the second section, the component being expandable from a compressed configuration to an expanded configuration when released into an aneurysm from a catheter.
2. The device of Claim 1, wherein the first section comprises a first material and the second section comprises a second material different from the first material, the first and second sections being coupled to each other.
3. The device of Claim 1, wherein the component further comprises a third section coupled to the second section, the third section having an average porosity different from the porosity of the second section.
4. The device of Claim 3, wherein the second section comprises a second material and the third section comprises a third material different from the second material.
5. The device of Claim 3, wherein the third section porosity is different from the first section porosity.
6. The device of Claim 5, wherein the first section comprises an average porosity of between about 1 μm and about 150 μm , and the third section comprises an average porosity of between 150 μm and about 300 μm .
7. The device of Claim 1, wherein in the expanded configuration, the component comprises a substantially spherical shape that is divided crosswise into the first and second sections.
8. The device of Claim 1, wherein the component further comprises an expansion-limiting coating configured to control an expansion rate of the component.
9. The device of Claim 1, wherein the first section comprises an average porosity of between about 1 μm and about 100 μm , and the second section comprises an average porosity of between about 100 μm and about 200 μm .
10. The device of Claim 1, wherein a shape of the component is selected from the group consisting of cylinders, hemispheres, polyhedrons, prolate spheroids, oblate spheroids, plates, bowls, hollow structures, clover shapes, non-spherical surface of revolution, and combinations thereof.

11. The device of Claim 10, further comprising a second foam component having a shape selected from the group consisting of spheres, cylinders, hemispheres, polyhedrons, prolate spheroids, oblate spheroids, plates, bowls, hollow structures, clover shapes, non-spherical surface of revolution, and combinations thereof.

12. The device of Claim 11, wherein the foam component and the second foam component are different sizes from each other.

13. The device of Claim 11, wherein the foam component and the second foam component are different shapes from each other.

14. The device of Claim 11, wherein the foam component and the second foam component have mating structures configured to abut each other in a complementary configuration and restrict at least degrees of freedom of motion of each of the foam component and the second foam component.

15. A system for treatment of an aneurysm, comprising:

a plurality of foam components being expandable from a compressed configuration to an expanded configuration when released into an aneurysm from a catheter, each of the plurality of components having an average porosity that is different from an average porosity of another of the plurality of components, the plurality of components being positionable within the aneurysm to form a composite foam component having a composite porosity configured to provide a therapeutic effect.

16. The system of Claim 15, wherein each of a first group of the plurality of components comprises a first average porosity, and each of a second group of the plurality of components comprises a second average porosity different from the first average porosity.

17. The system of Claim 16, wherein the first average porosity is between about 1 μm and about 100 μm , and the second average porosity is between about 100 μm and about 200 μm .

18. The system of Claim 15, wherein a shape of at least one of the plurality of components is substantially spherical.

19. The system of Claim 15, wherein a shape of at least one of the plurality of components is selected from the group consisting of spheres, cylinders, hemispheres, polyhedrons, prolate spheroids, oblate spheroids, plates, bowls, hollow structures, clover shapes, non-spherical surface of revolution, and combinations thereof.

20. The system of Claim 15, wherein each of the plurality of components is different sizes from another of the plurality.

21. The system of Claim 15, wherein each of the plurality of components is different shapes from another of the plurality.

22. The system of Claim 15, wherein a first of the plurality of components and a second of the plurality of components have mating structures configured to abut each other in a complementary configuration and restrict at least degrees of freedom of motion of each of the first and second of the plurality of components.

23. A device for treatment of an aneurysm, comprising:

a foam component having a region of variable average porosity and a radiopaque marker, the marker being visible under imaging and positionable relative to the region so as to facilitate identification and orientation of the component when implanted into the aneurysm from a catheter, the component being expandable from a compressed configuration to an expanded configuration when released into the aneurysm.

24. The device of Claim 23, wherein the region comprises a first section and a second section having an average porosity different from an average porosity of the first material.

25. The device of Claim 24, wherein the region further comprises a third section adjacent to the second section, the third section having an average porosity different from the porosity of the second section.

26. The device of Claim 25, wherein the third section porosity is different from the first section porosity.

27. The device of Claim 23, wherein the region comprises a first material and a second material different from the first material, the first and second materials being coupled to each other.

28. The device of Claim 23, wherein the marker comprises a material blended into the component such that the component is visible under imaging.

29. The device of Claim 23, wherein the marker is coupled to an exterior of the component.

30. The device of Claim 23, wherein a shape of the component is selected from the group consisting of cylinders, hemispheres, polyhedrons, prolate spheroids, oblate spheroids,

plates, bowls, hollow structures, clover shapes, non-spherical surface of revolution, and combinations thereof.

31. The device of Claim 30, further comprising a second foam component having a shape selected from the group consisting of spheres, cylinders, hemispheres, polyhedrons, prolate spheroids, oblate spheroids, plates, bowls, hollow structures, clover shapes, non-spherical surface of revolution, and combinations thereof.

32. The device of Claim 31, wherein the foam component and the second foam component are different sizes from each other.

33. The device of Claim 31, wherein the foam component and the second foam component are different shapes from each other.

34. The device of Claim 31, wherein the foam component and the second foam component have mating structures configured to abut each other in a complementary configuration and restrict at least degrees of freedom of motion of each of the foam component and the second foam component.

35. A method for treatment of an aneurysm, comprising:
advancing a foam component through a catheter lumen, the component comprising a first section having a different average porosity than an average porosity of a second section;
releasing the component into the aneurysm;
allowing the component to expand from a compressed configuration to an expanded configuration within the aneurysm; and
positioning the component within the aneurysm such that the first section is positioned away from the aneurysm neck and the second section is positioned adjacent to a neck of the aneurysm.

36. The method of Claim 35, wherein the positioning comprises rotating the component.

37. The method of Claim 35, wherein the positioning comprises maintaining a position of the component relative to the aneurysm neck during expansion to the expanded configuration.

38. The method of Claim 35, wherein the aneurysm is disposed adjacent at bifurcation of a parent vessel into two efferent vessels, and wherein the positioning further

comprises positioning the second section adjacent to the bifurcation and permitting flow through the bifurcation and into at least one of the first or second efferent vessels.

39. The method of Claim 35, wherein the component further comprises a third section disposed between the first and second sections, the third section having an average porosity different than the porosity of the second section, wherein the positioning comprises positioning the component such that the first section is positioned at a fundus of the aneurysm and the third section is positioned between the fundus and the aneurysm neck.

40. The method of Claim 35, further comprising injecting a liquid embolic material into the aneurysm after positioning the component.

41. The method of Claim 35, further comprising implanting a support structure into the aneurysm before releasing the component into the aneurysm, and wherein the releasing comprises releasing the component through a wall of the support structure into the aneurysm.

42. The method of Claim 41, wherein the support structure comprises a substantially enclosed interior cavity, and the releasing further comprises releasing the component into the interior cavity.

43. A method for treatment of an aneurysm, comprising:
positioning a distal opening of a catheter adjacent to the aneurysm; and
advancing a framing device into the aneurysm, the framing device having an interior cavity and an exterior surface for contacting a wall of the aneurysm; and
while at least a portion of the device exterior surface is in contact with the aneurysm wall, releasing at least one expandable component into the device cavity;
wherein the framing device comprises at least one of a foam or a braided structure.

44. The method of Claim 43, wherein the aneurysm is a saccular aneurysm and before releasing the at least one expandable component, the device is expanded such that the exterior surface contacts an inner surface of the aneurysm having a cross-sectional profile greater than a passing profile of a neck of the aneurysm.

45. The method of Claim 43, wherein the releasing comprises causing the device to expand into contact with the aneurysm wall.

46. The method of Claim 43, wherein the device comprises a substantially closed three-dimensional expanded shape.

47. The method of Claim 43, wherein the component comprises at least one of a foam, a coil, or a braided structure.

48. The method of Claim 46, wherein the three-dimensional shape is selected from the group consisting of spheres, cylinders, hemispheres, polyhedrons, prolate spheroids, oblate spheroids, non-spherical surface of revolution, and combinations thereof.

49. The method of Claim 43, wherein the device comprises for quadrants, and the releasing comprises causing at least a portion of each quadrant to contact the aneurysm wall.

50. The method of Claim 49, wherein the device comprises a substantially spherical expanded shape.

51. The method of Claim 43, wherein the device comprises an opening to the device cavity, and the releasing comprises injecting the at least one expandable component into the device cavity through the device aperture.

52. The method of Claim 51, wherein the device comprises a braided material and the opening is an opening formed between filaments of the braided material.

53. The method of Claim 51, wherein the framing device has a closed end and an open end opposite the closed end, the open end forming the opening, and wherein the releasing advancing comprises aligning the opening with a neck of the aneurysm.

54. A method for treatment of an aneurysm, comprising:

implanting a stent into a lumen of a parent vessel from which an aneurysm arises such that the stent extends across at least a portion of the aneurysm; and

releasing at least one expandable component into an inner volume of the aneurysm between a wall of the aneurysm and an outer surface of the stent;

wherein the expandable component comprises at least one of a foam or a braided structure.

55. The method of Claim 54, wherein the aneurysm comprises a fusiform aneurysm.

56. The method of Claim 54, wherein the aneurysm comprises a wide-neck aneurysm.

57. The method of Claim 54, wherein the portion comprises a neck.

58. The method of Claim 54, wherein the at least one expandable component comprises a plurality of expandable components, and the releasing comprises releasing the plurality based on relative sizes of the expandable components.

59. The method of Claim 58, further comprising selecting the at least one expandable component based on the shape of the inner volume.

60. The method of Claim 59, wherein the at least one expandable component comprises a shape selected from the group consisting of cylinders, hemispheres, polyhedrons, prolate spheroids, oblate spheroids, plates, bowls, hollow structures, clover shapes, non-spherical surface of revolution, and combinations thereof.

61. The method of Claim 54, wherein the at least one expandable component comprises a first portion having an average porosity greater than that of a second portion thereof, and the releasing comprises positioning the at least one expandable component such that the first portion abuts an outer surface of the stent device and the second portion extends along an inner wall of the aneurysm.

62. The method of Claim 54, wherein the releasing comprises releasing a plurality of expandable components into the inner volume.

63. The method of Claim 54, wherein the aneurysm inner volume extends around a circumference of the stent device, and the releasing comprises depositing a plurality of expandable components into the inner volume around the circumference of the stent device.

64. The method of Claim 63, wherein at least one of the plurality of expandable components comprises a flat or cylindrically shaped surface, and the releasing comprises positioning the at least one of the plurality of expandable components such that the flat or cylindrically shaped surface substantially conforms to an outer surface of the stent device.

65. A system for treatment of an aneurysm, comprising:
an intrasaccular device comprising first and second expandable components adapted to transition from a compressed configuration to an expanded configuration when deployed into the aneurysm, the first and second components being interconnected by a non-helical coupling such that the first and second components can be advanced as an interconnected unit, into the aneurysm;
wherein the first component comprises at least one of a shape or an average porosity different from a shape or an average porosity of the second component.
66. The system of Claim 65, wherein the first component shape is selected from the group consisting of cylinders, hemispheres, polyhedrons, prolate spheroids, oblate spheroids, plates, bowls, hollow structures, clover shapes, non-spherical surface of revolution, and combinations thereof.
67. The system of Claim 65, wherein the second component comprises a substantially spherical shape.
68. The system of Claim 65, wherein at least one of the first or second components comprises a foam or a braided structure.
69. The system of Claim 65, wherein at least one of the first or second components comprises a coil.
70. The system of Claim 65, further comprising a third component interconnected with the second component such that the first, second, and third components are interconnected in series.
71. The system of Claim 65, wherein the coupling interconnecting the first and second components comprises a filament.
72. The system of Claim 65, wherein the coupling has a preset shape such that in an expanded position, the first and second components are spaced relative to each other at a preset orientation.
73. A system for treatment of an aneurysm, comprising:
an intrasaccular device comprising at least three expandable components adapted to transition from a compressed configuration to an expanded configuration when deployed into the aneurysm, each of the at least three components being interconnected to

at least two of the at least three components such that at least three expandable components can be advanced as an interconnected unit, into the aneurysm.

74. The system of Claim 73, wherein the at least three expandable components comprises at least four expandable components.

75. The system of Claim 74, wherein at least two of the at least four expandable components is interconnected with at least three of the at least four expandable components such that the device comprises a multi-planar shape.

76. The system of Claim 73, wherein the at least three components are interconnected by filaments.

77. The system of Claim 73, wherein at least three components are interconnected by filaments having preset shapes such that in an expanded position, the at least three components are spaced relative to each other at a preset orientation.

78. The system of Claim 73, wherein the device comprises at least one central expandable component positioned such that, when the device is in an expanded configuration, the central expandable component is centrally interconnected with a plurality of the expandable components.

79. The system of Claim 78, wherein the at least one central expandable component has an expanded size greater than an expanded size of each remaining one of the plurality of components.

80. The system of Claim 75, wherein the multi-planar shape comprises a polyhedron.

81. A method for treatment of an aneurysm, comprising:

advancing an intrasaccular device toward the aneurysm through a lumen of a catheter, the device comprising a plurality of expandable components each adapted to transition from a compressed configuration to an expanded configuration when deployed into the aneurysm from the catheter, each of the plurality of components being interconnected by a coupling.

82. The method of Claim 81, further comprising:

advancing the device into the aneurysm such that a first component is disposed within the aneurysm and a second component, interconnected with the first component by the coupling, is disposed within the catheter lumen;

severing the coupling between the first and second components to release the first component into the aneurysm;

retaining the second component within the lumen; and

withdrawing the catheter.

83. The method of Claim 81, further comprising advancing a plurality of expandable components into the aneurysm prior to the severing.

84. The method of Claim 81, wherein each of the plurality of components is interconnected in series by the coupling.

85. The method of Claim 81, wherein the severing comprises proximally withdrawing the catheter relative to a second catheter such that the coupling between the first and second components is pinched between a distal end of the catheter and a rim of the second catheter.

86. The method of Claim 81, wherein the plurality of expandable components is arranged in descending size, and the advancing comprises allowing an initial expandable component deployed into the aneurysm to expand prior to advancing a subsequent expandable component into the aneurysm.

87. The method of Claim 86, wherein the advancing comprises observing a fit of expanded components within the aneurysm to determine whether to advance additional components into the aneurysm.

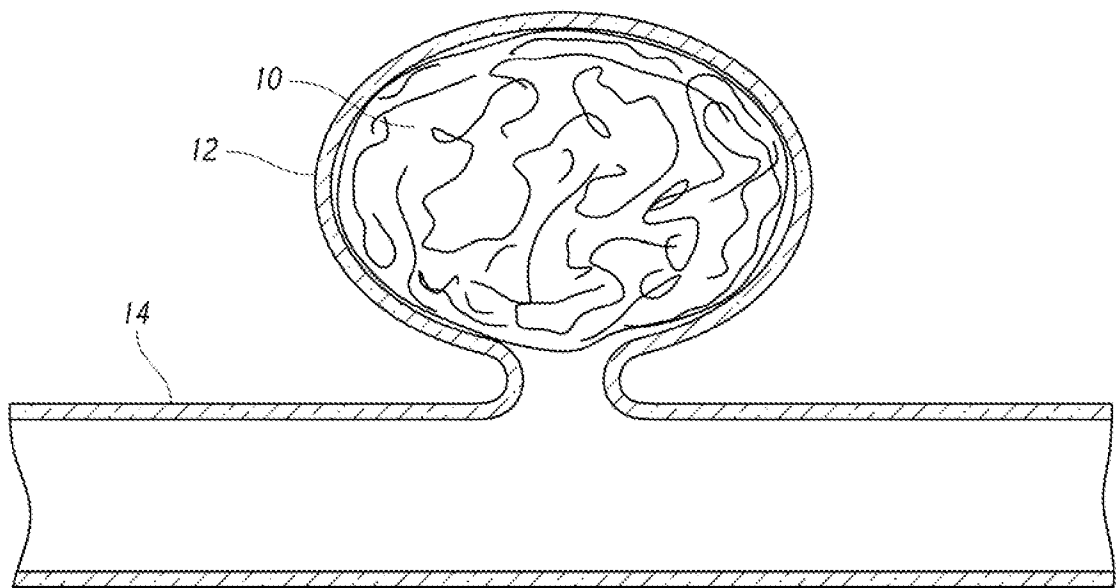

FIG. 1

20

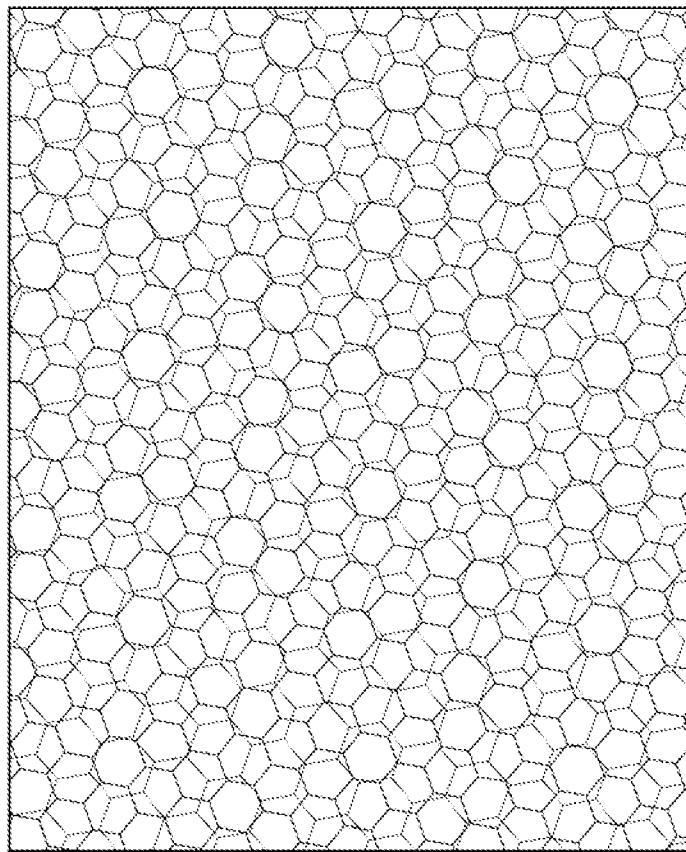

FIG. 2

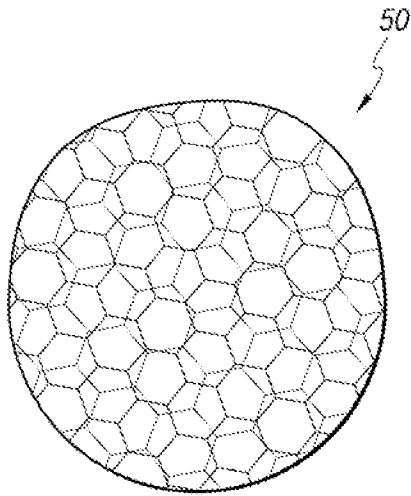

FIG. 3

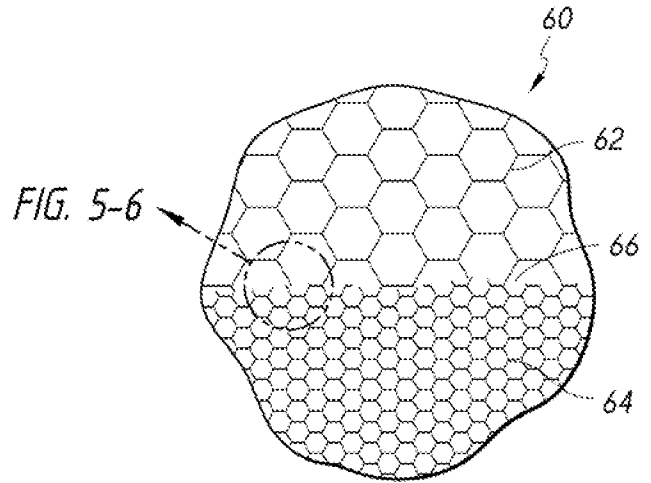

FIG. 4

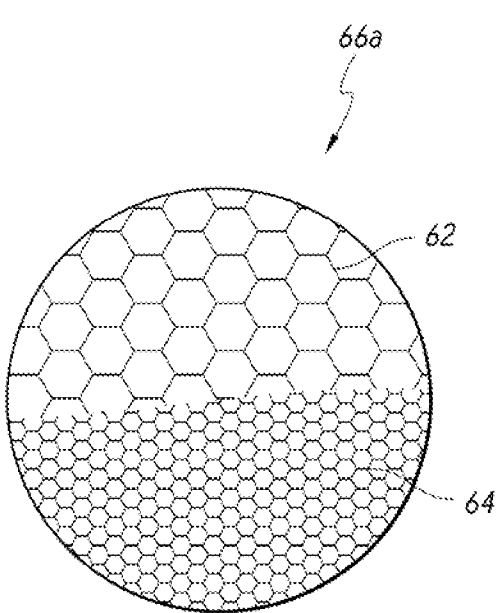

FIG. 5

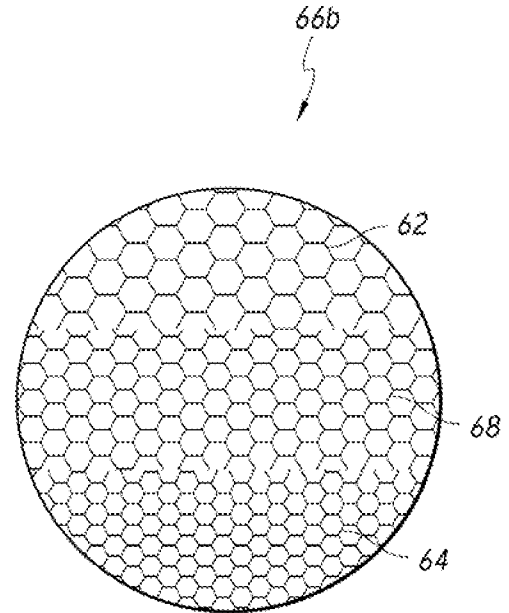

FIG. 6

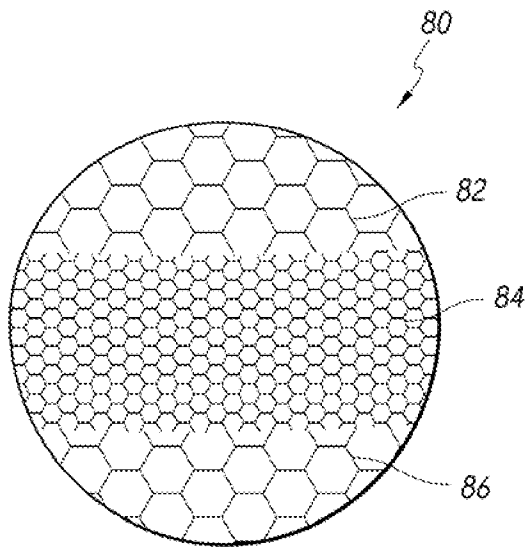

FIG. 7

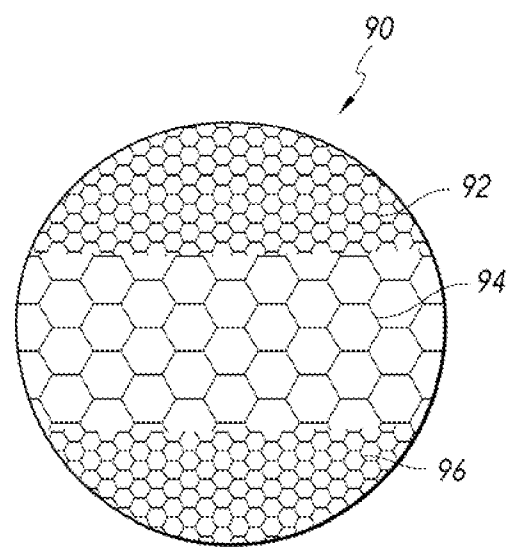

FIG. 8

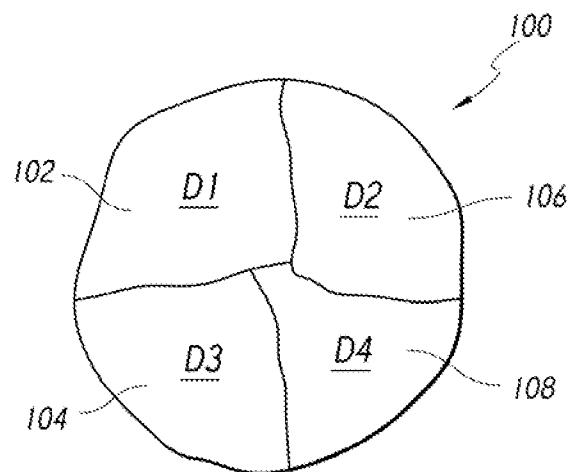

FIG. 9

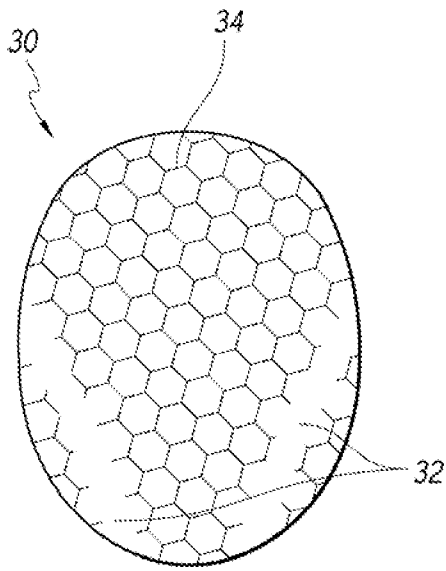

FIG. 10

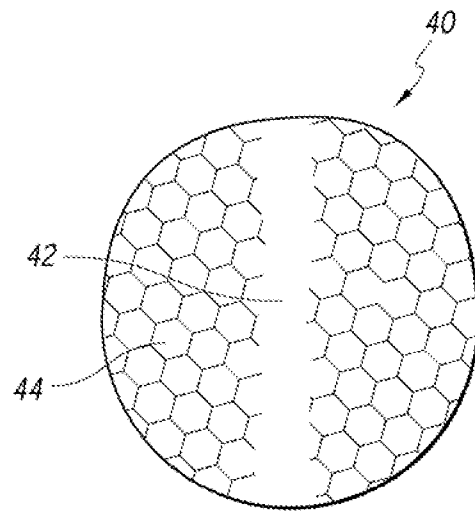

FIG. 11

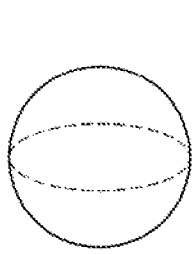

FIG. 12A

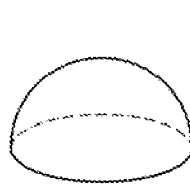

FIG. 12B

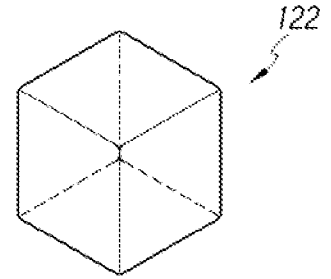

FIG. 12C

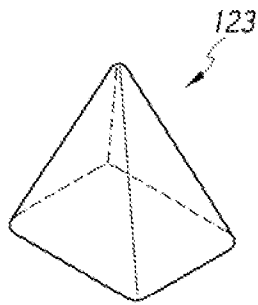

FIG. 12D

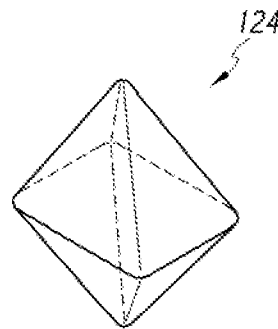

FIG. 12E

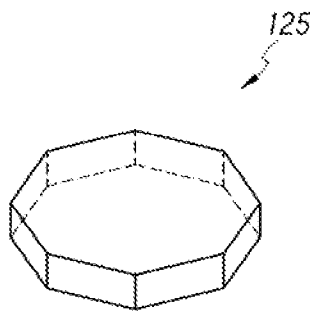

FIG. 12F

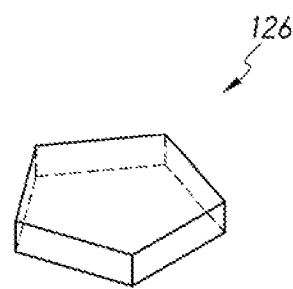

FIG. 12G

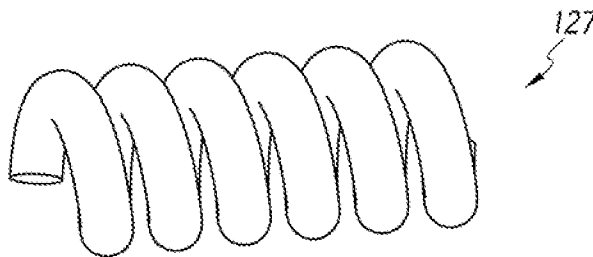

FIG. 12H

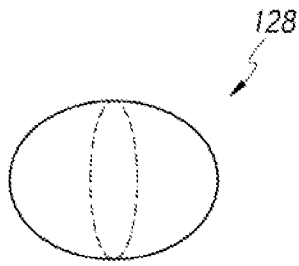

FIG. 12I

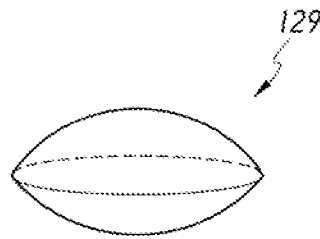

FIG. 12J

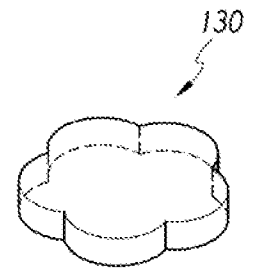

FIG. 12K

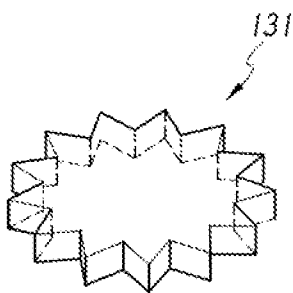

FIG. 12L

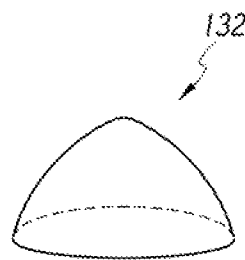

FIG. 12M

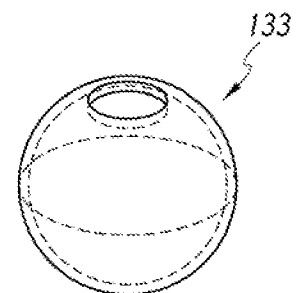

FIG. 12N

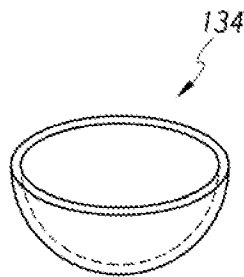

FIG. 12O

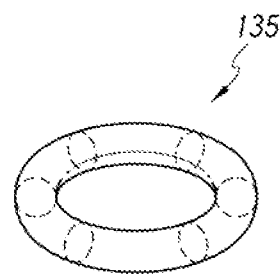

FIG. 12P

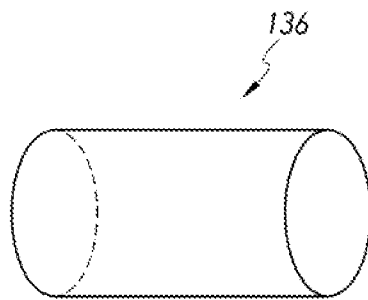

FIG. 12Q

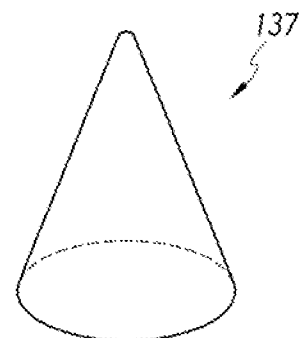

FIG. 12R

8/29

FIG. 13

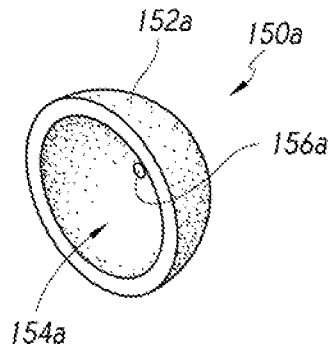

FIG. 14

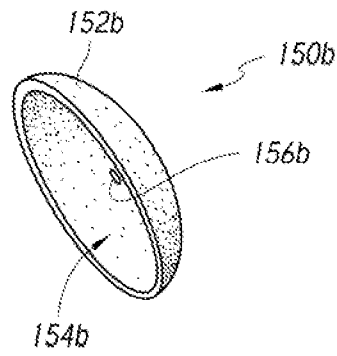
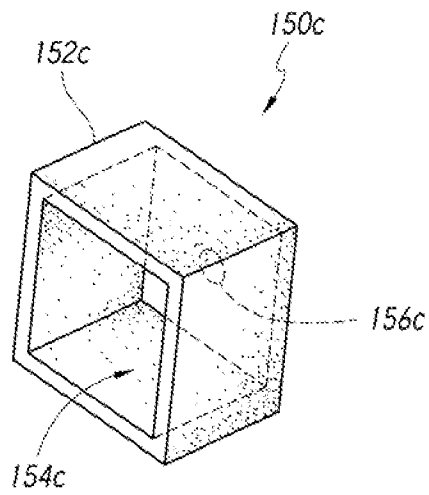

FIG. 15



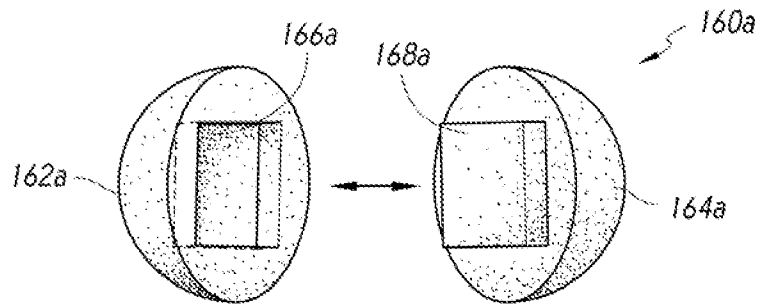

FIG. 16

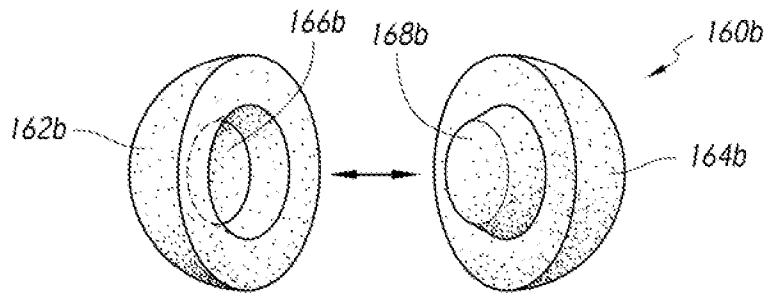

FIG. 17

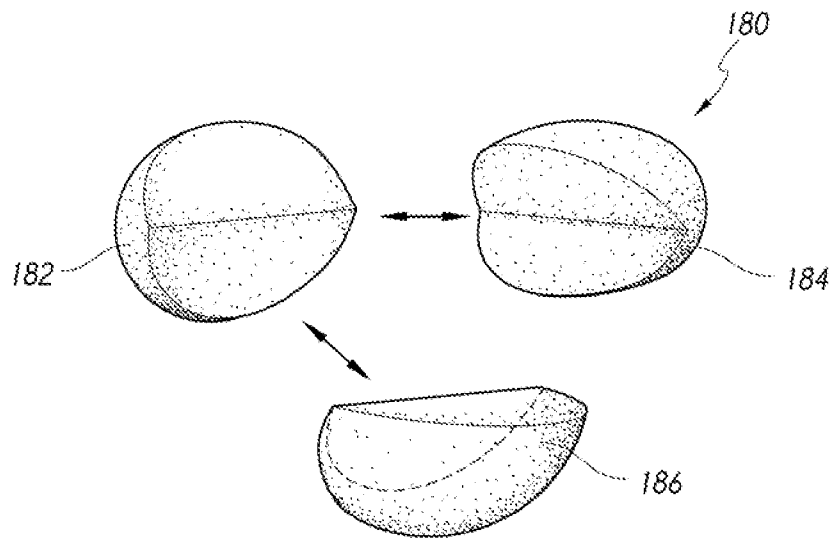

FIG. 18

10/29

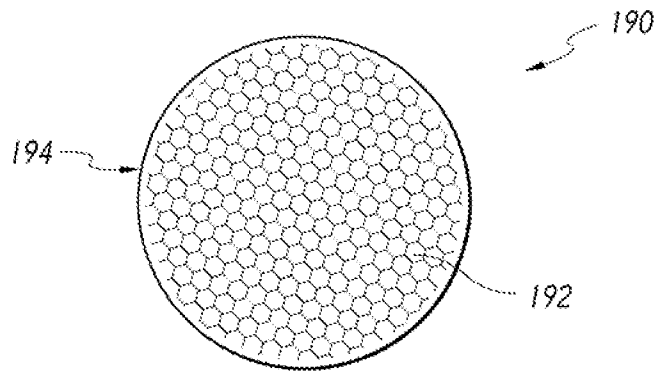

FIG. 19

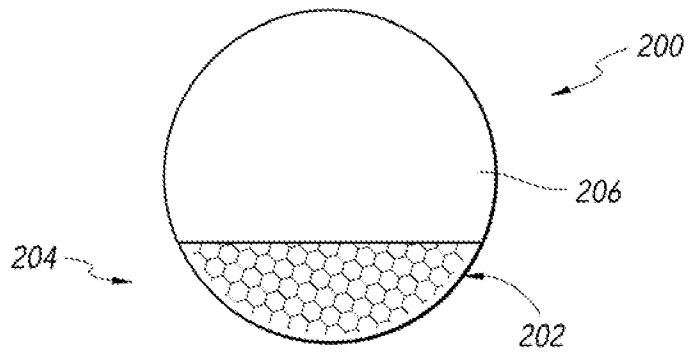

FIG. 20

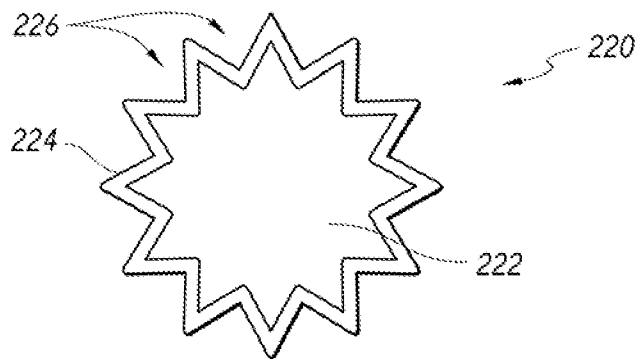

FIG. 21

11/29

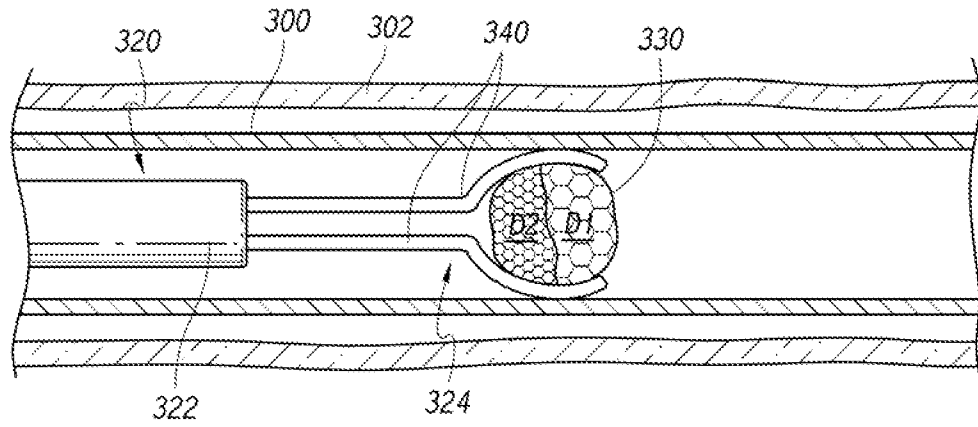

FIG. 22

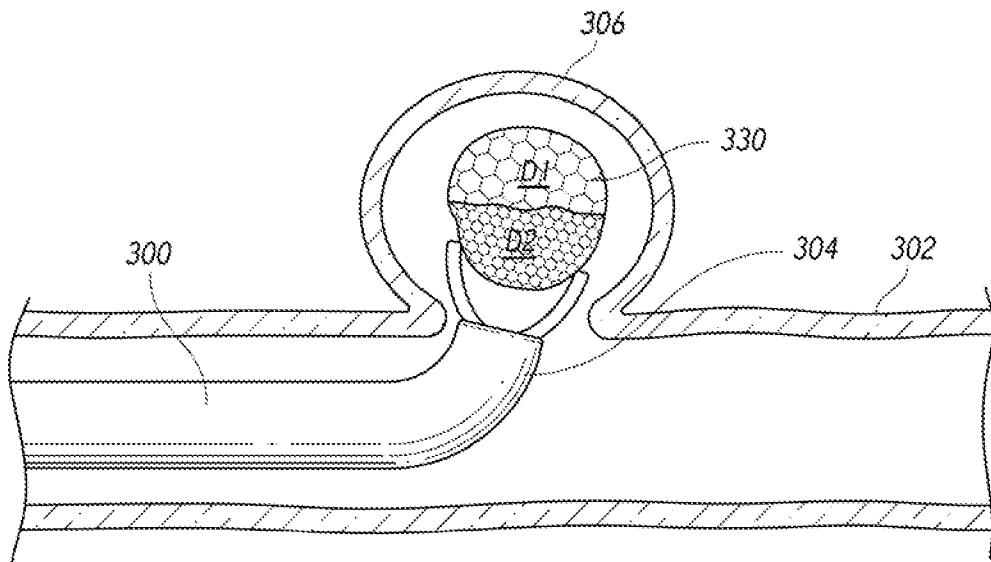

FIG. 23

12/29

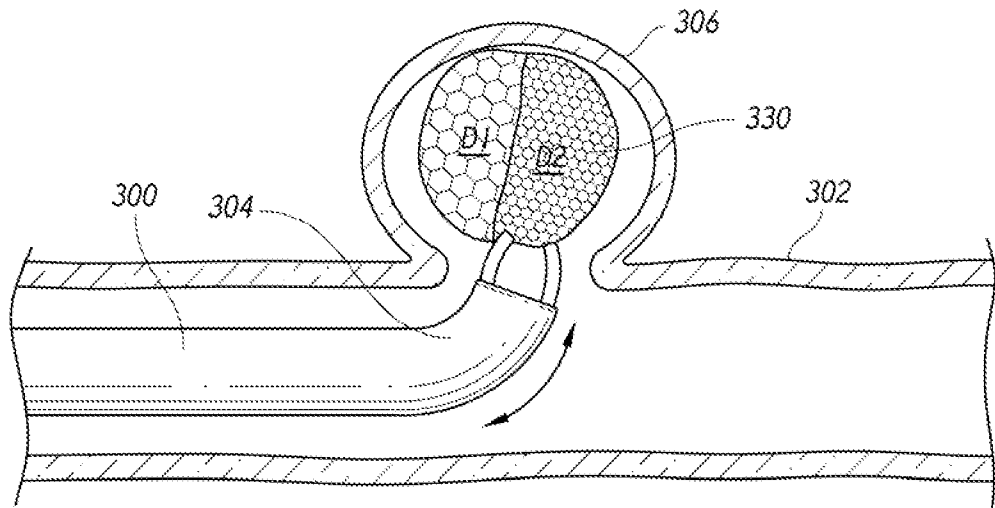

FIG. 24

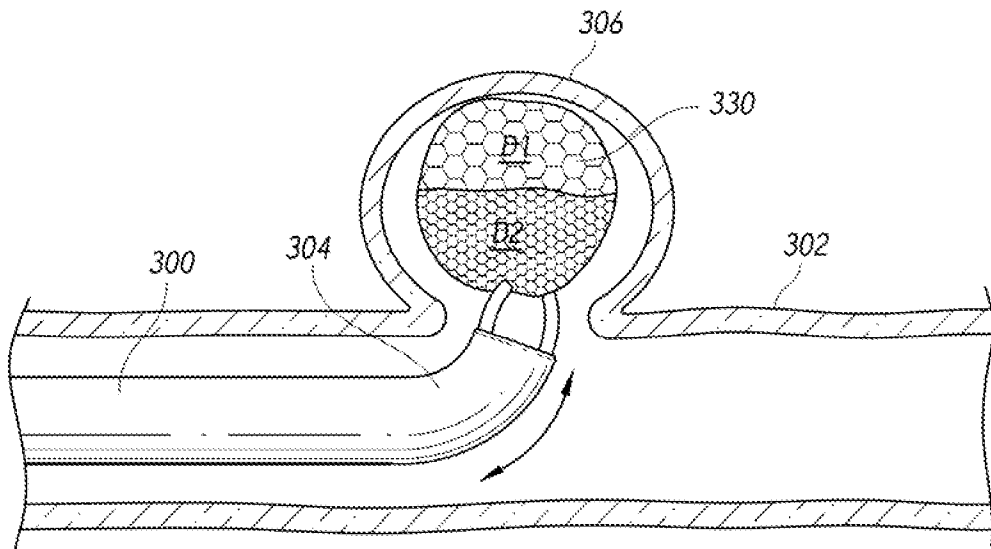

FIG. 25

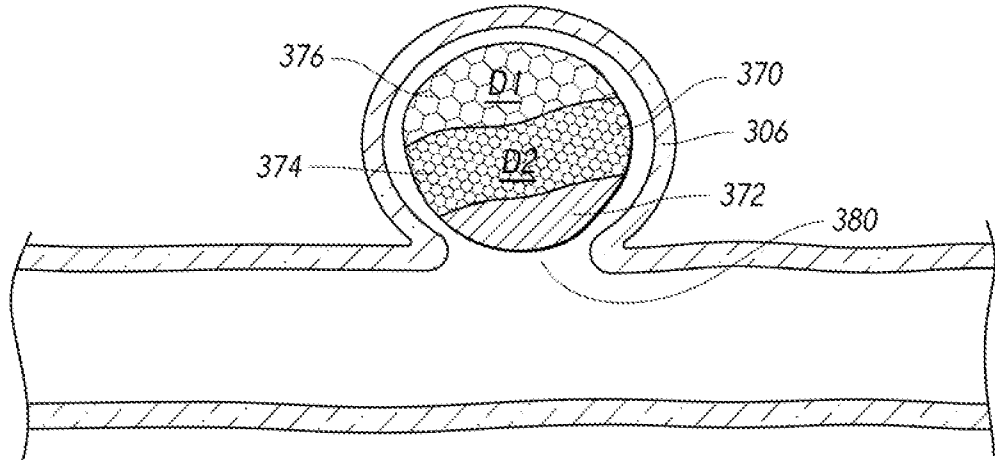

FIG. 26

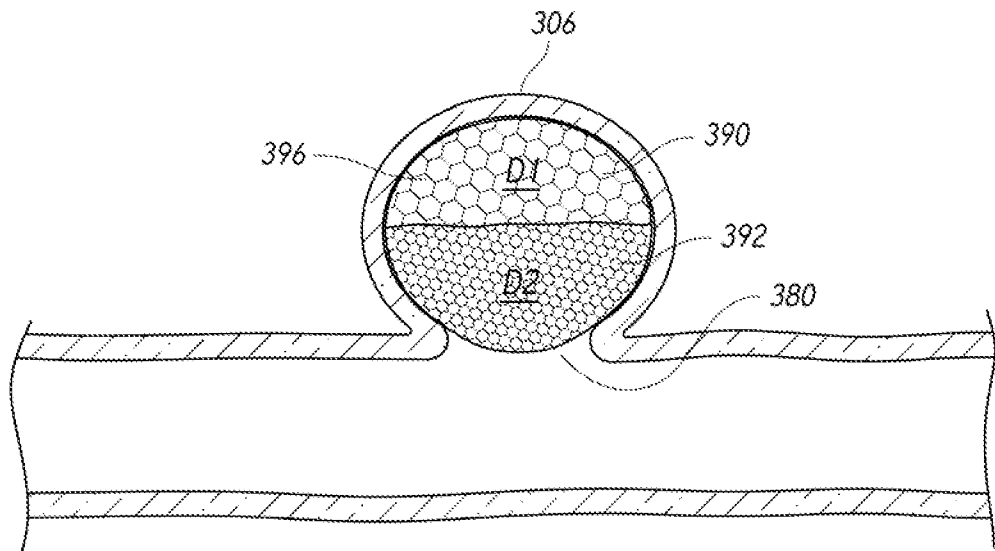

FIG. 27

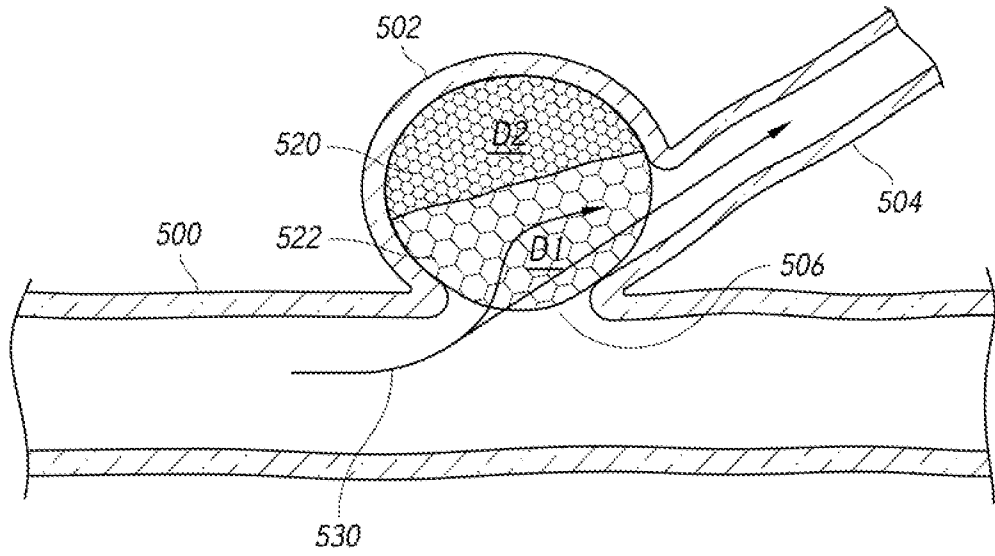

FIG. 28

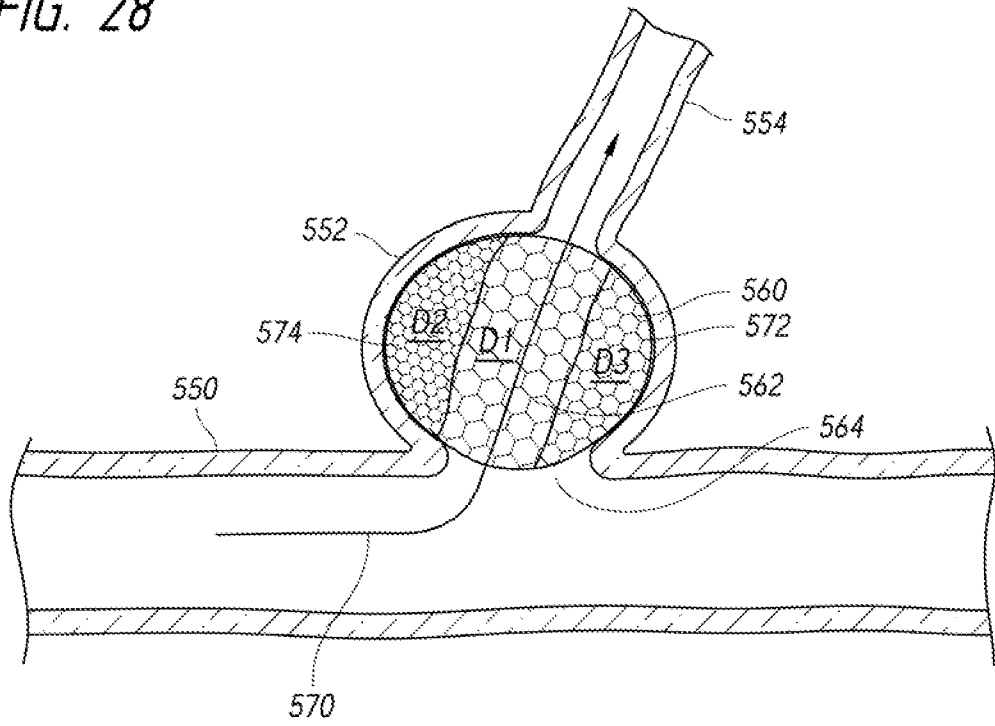

FIG. 29

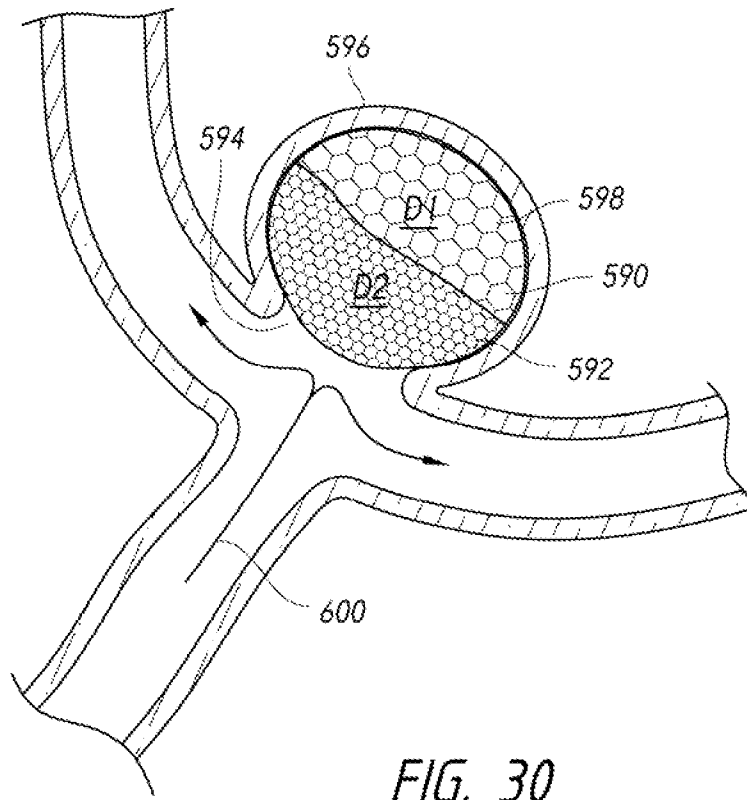

FIG. 30

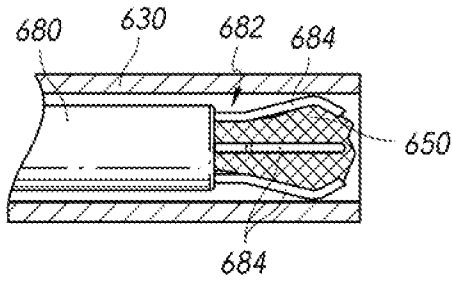

FIG. 31A

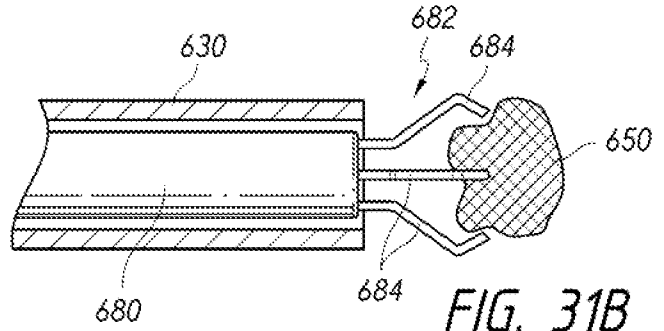

FIG. 31B

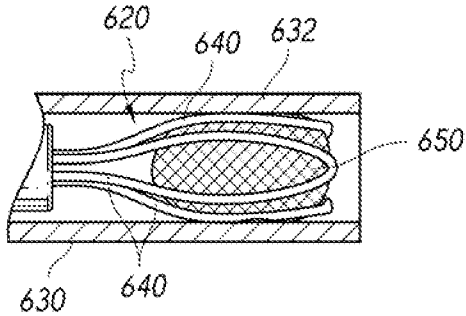

FIG. 32A

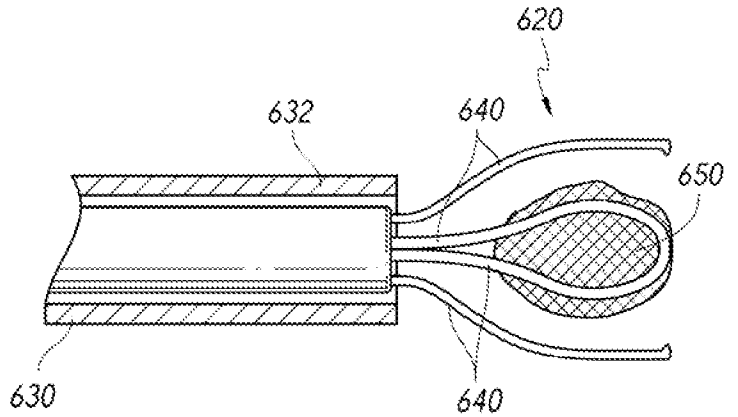

FIG. 32B

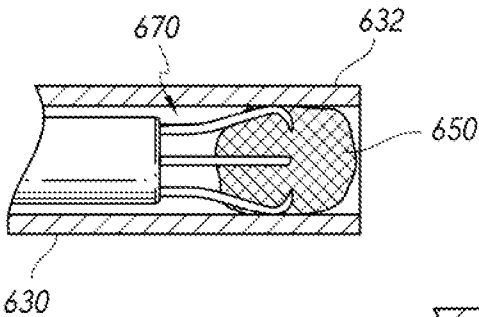

FIG. 33A

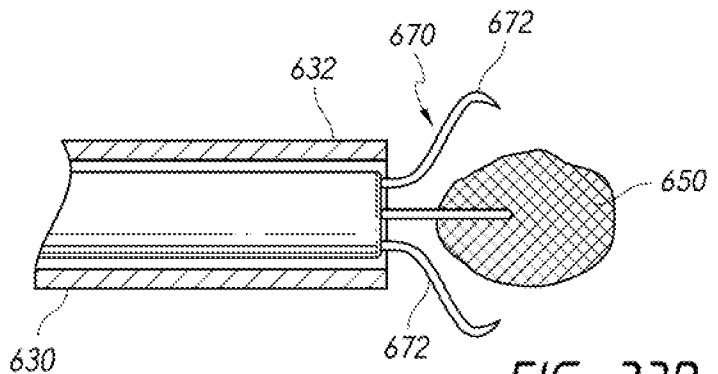

FIG. 33B

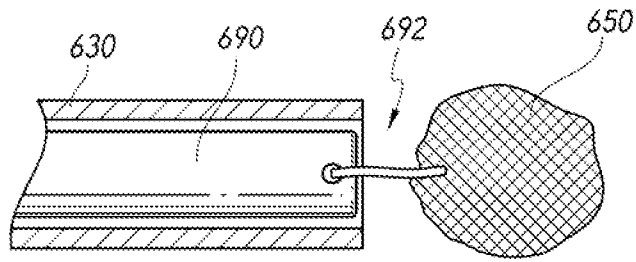

FIG. 34

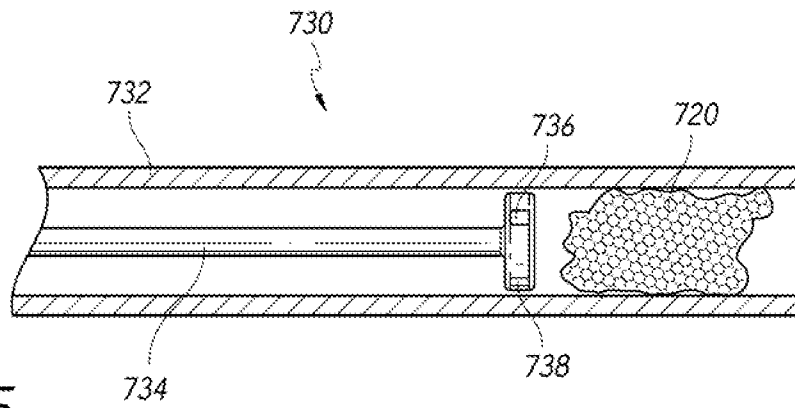

FIG. 35

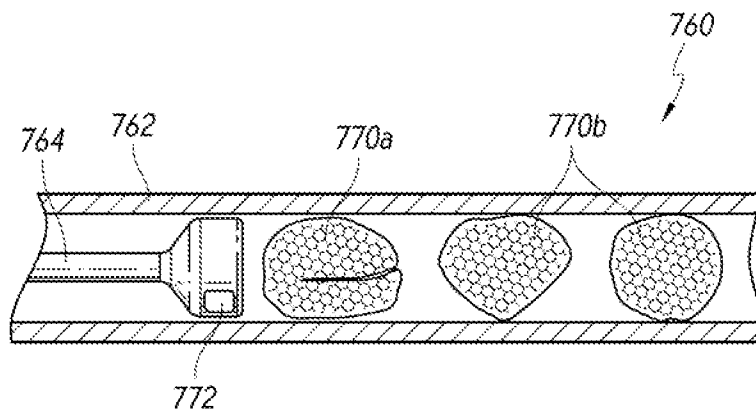

FIG. 36

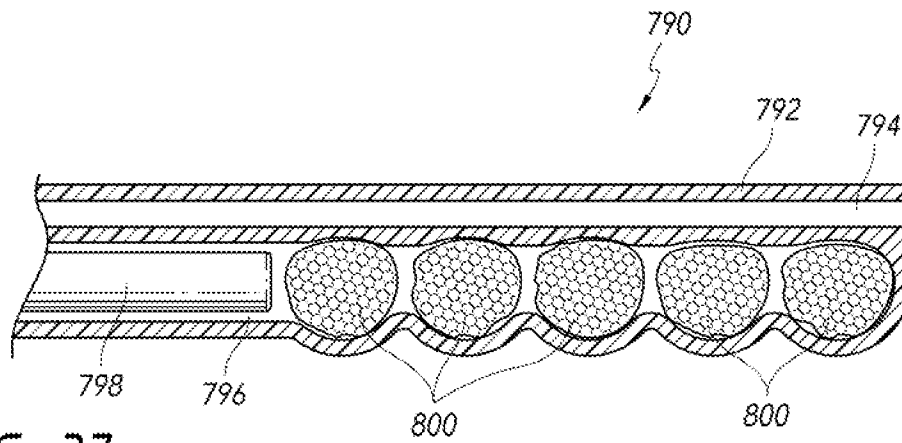

FIG. 37

18/29

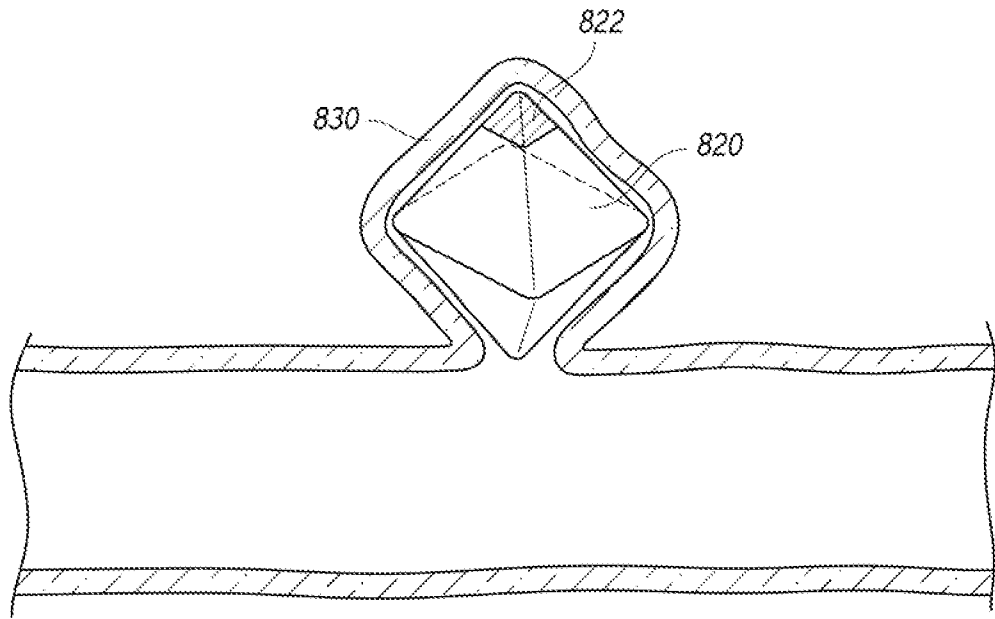

FIG. 38

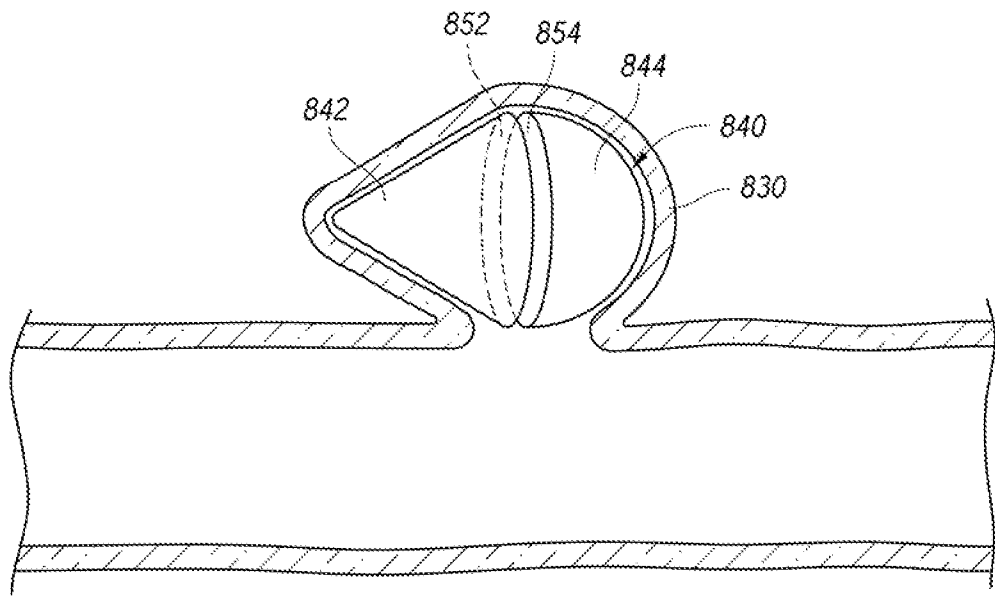

FIG. 39

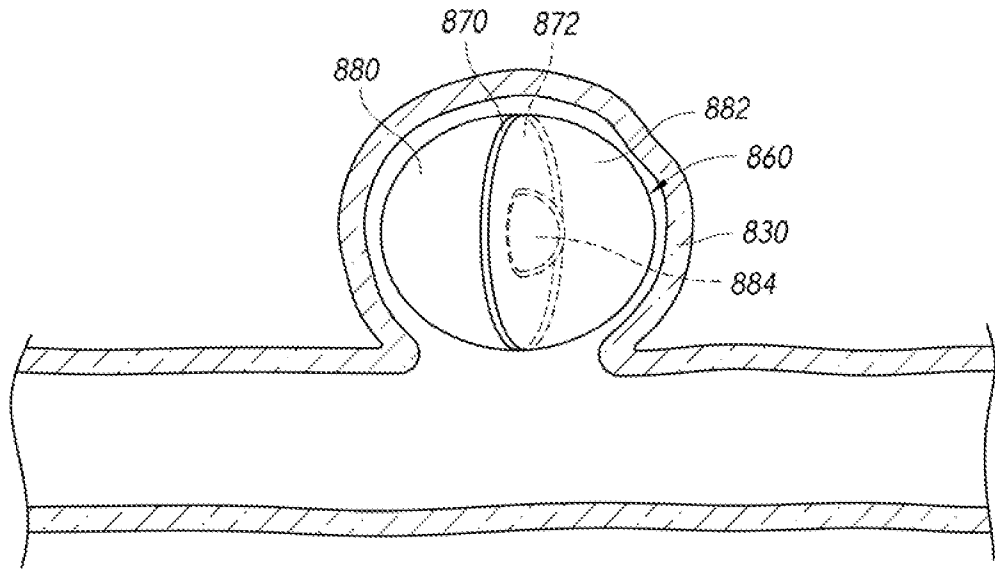

FIG. 40

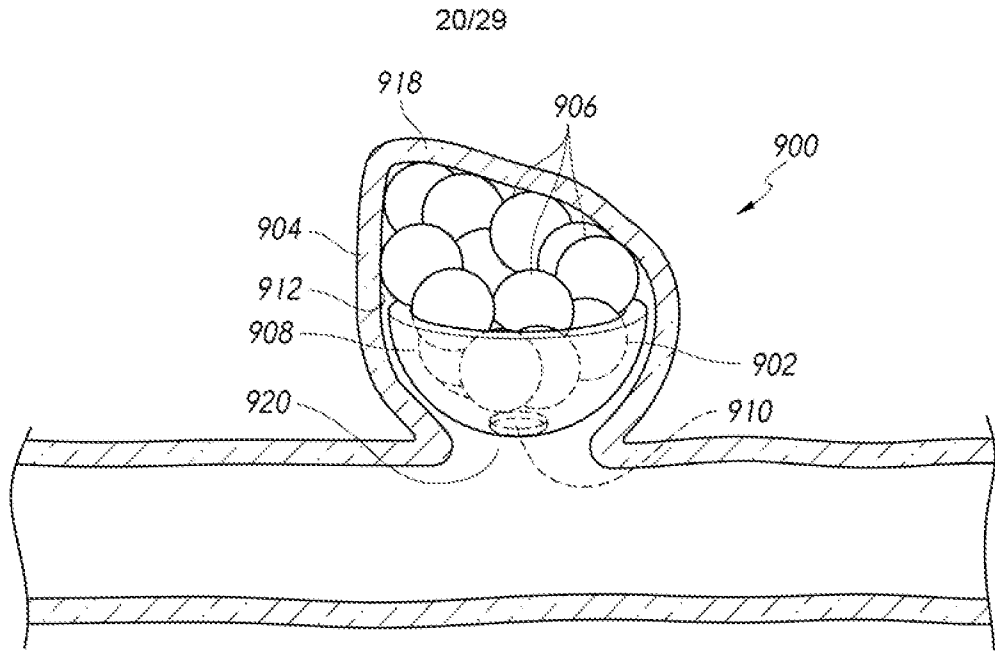

FIG. 41

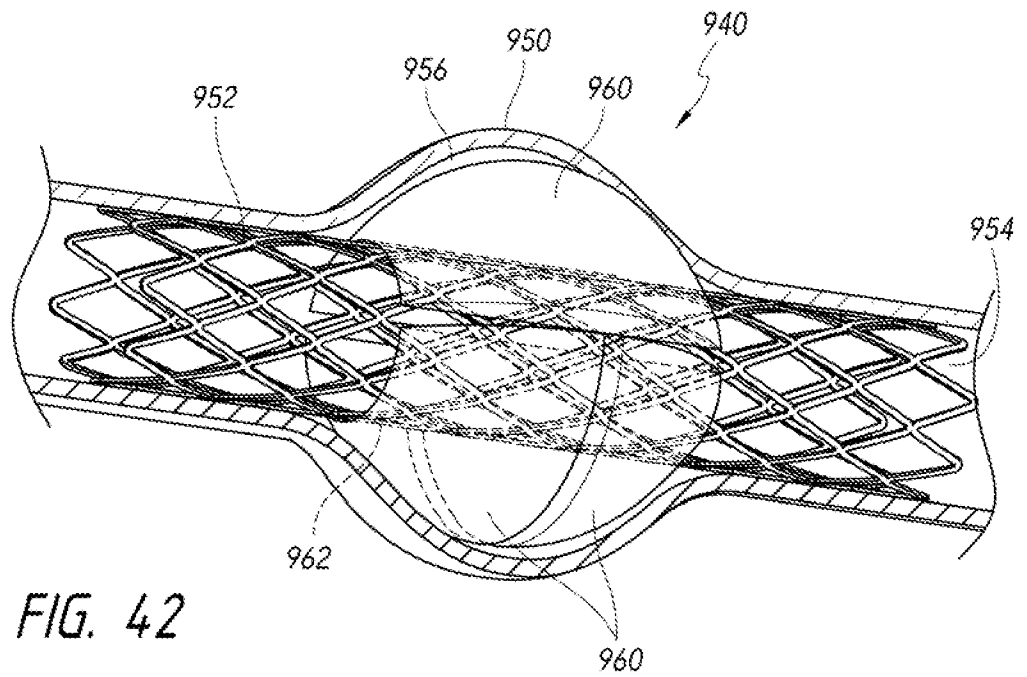

FIG. 42

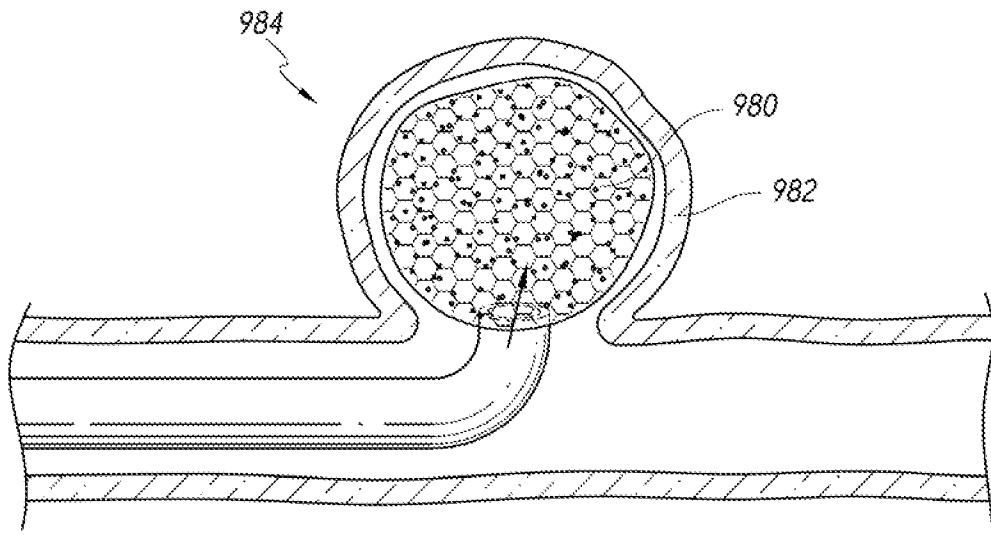

FIG. 43

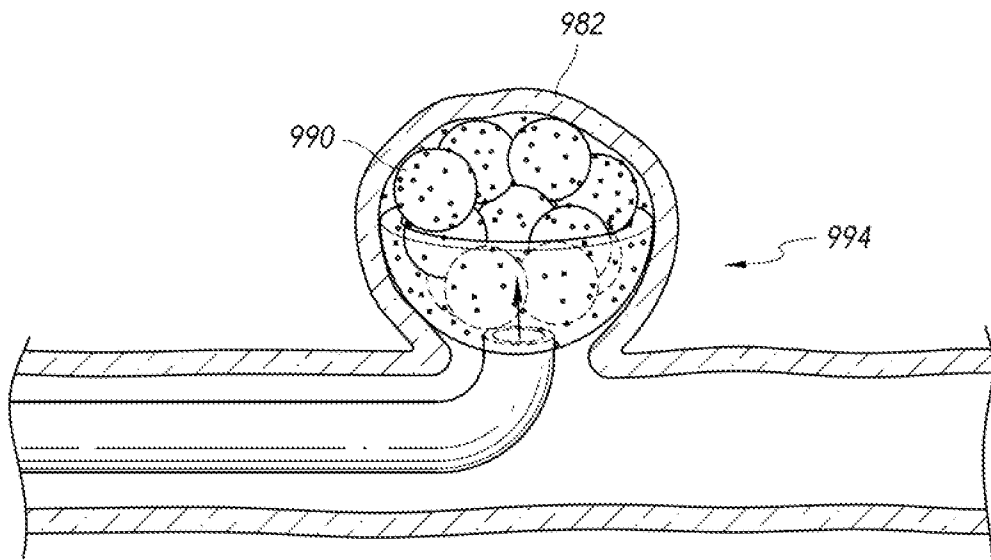

FIG. 44

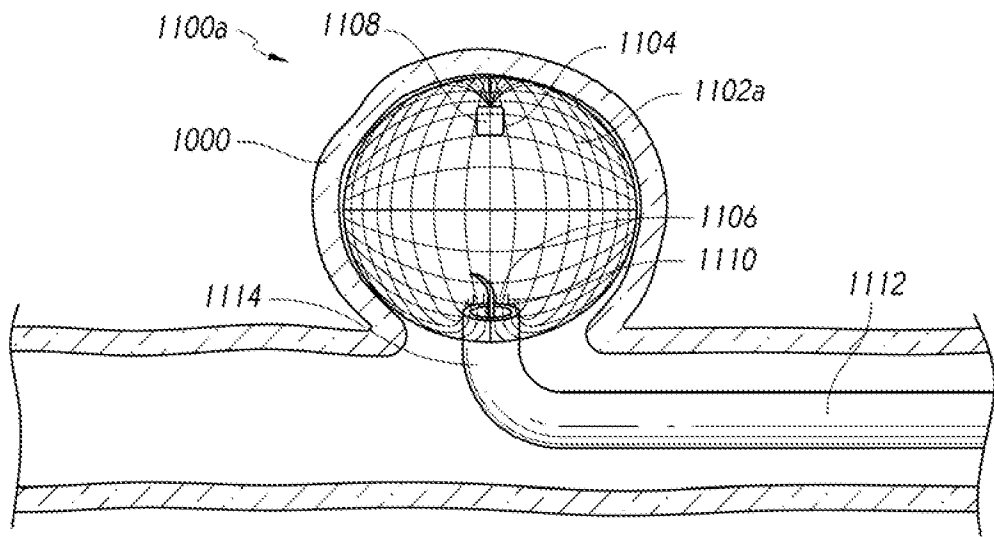

FIG. 45

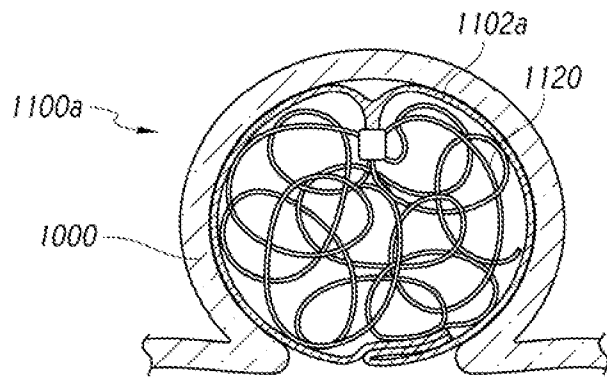

FIG. 46

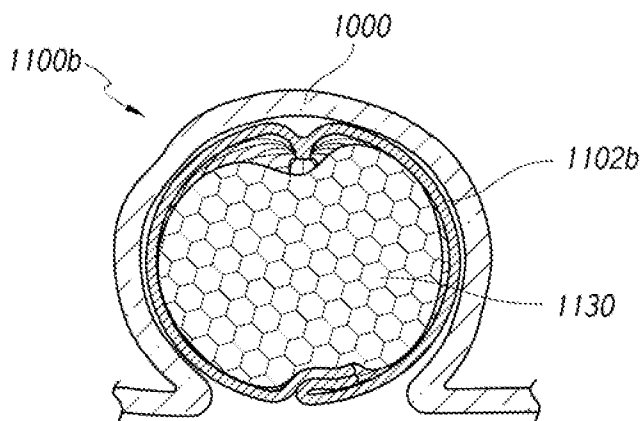

FIG. 47

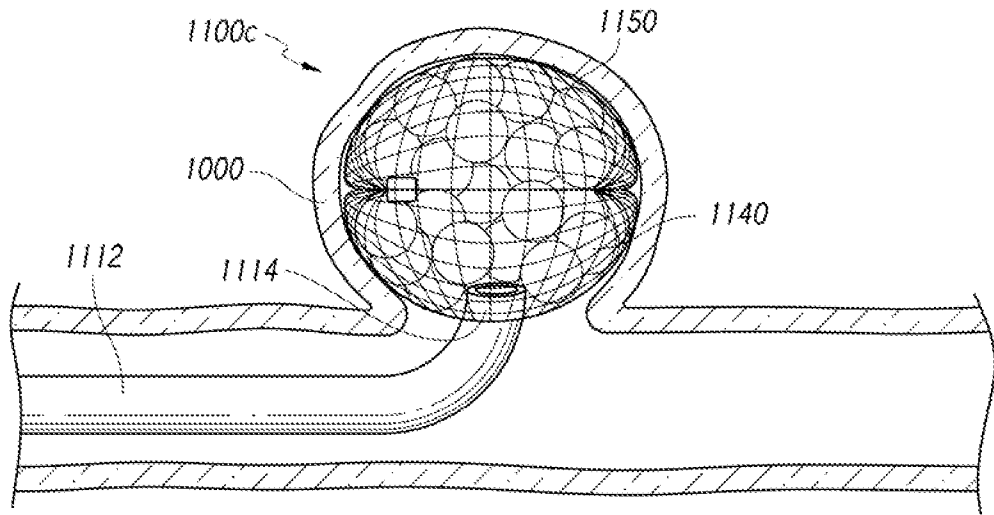

FIG. 48

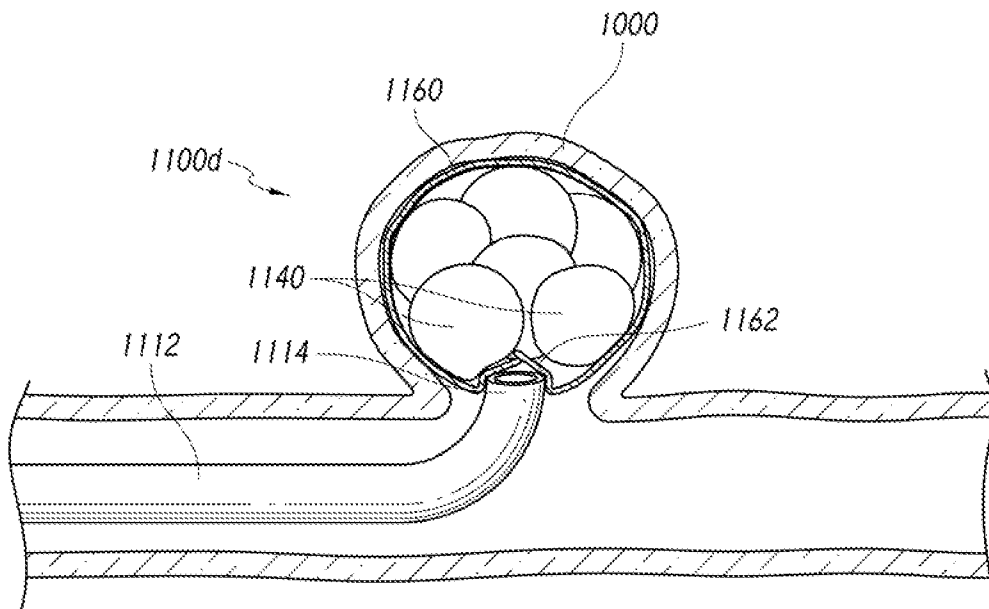

FIG. 49

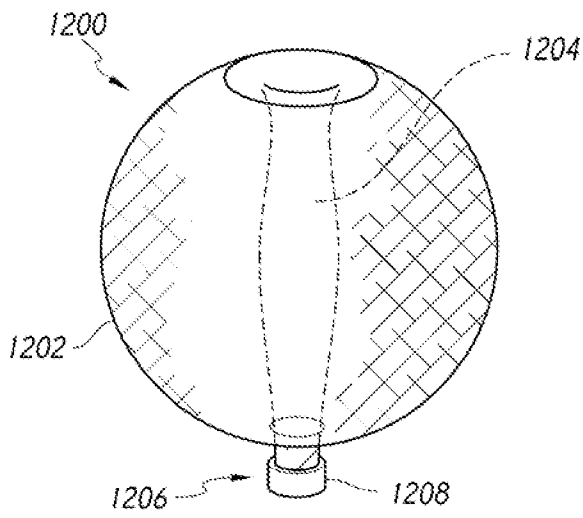

FIG. 50

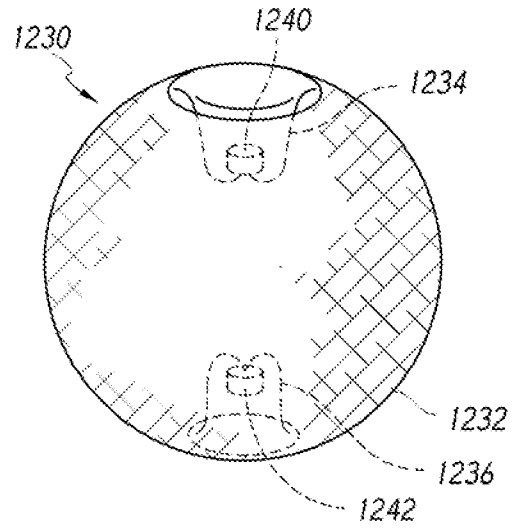

FIG. 51

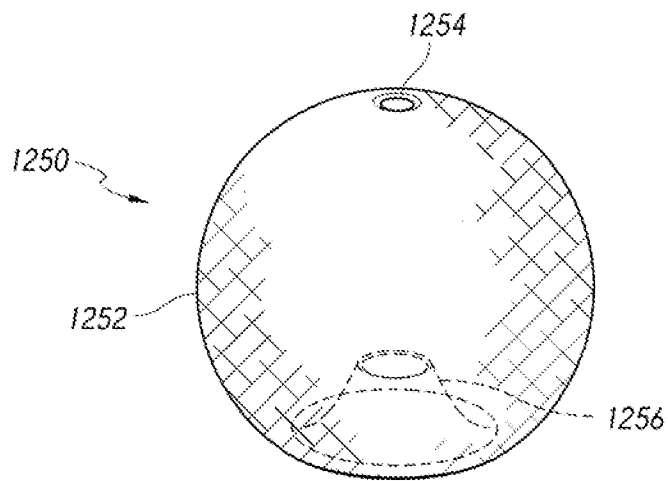

FIG. 52

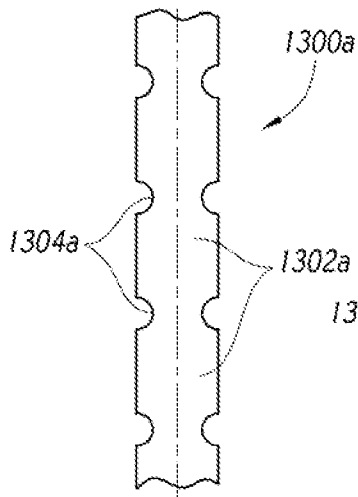

FIG. 53

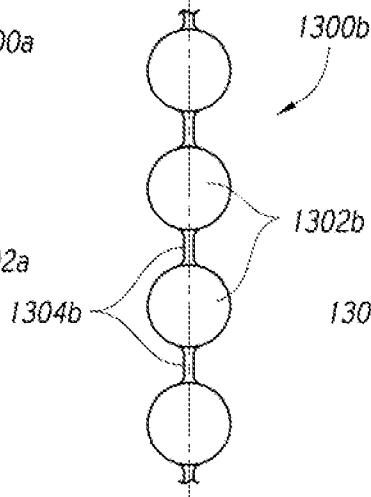

FIG. 54

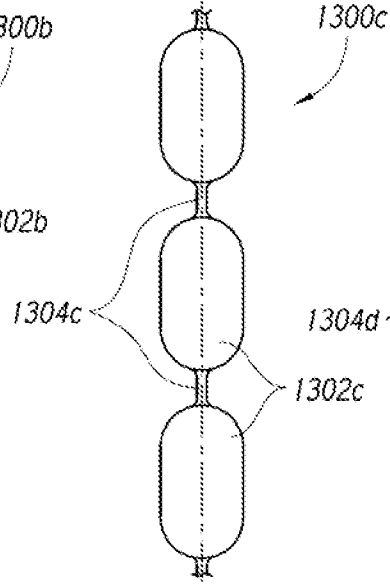

FIG. 55

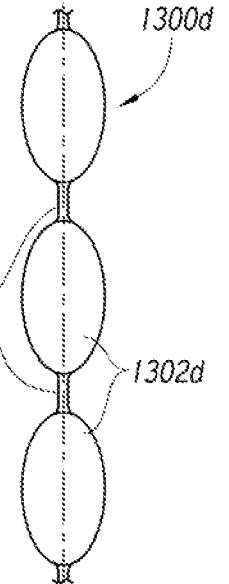

FIG. 56

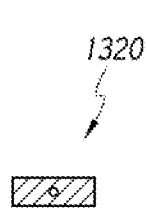

FIG. 57A



FIG. 57B

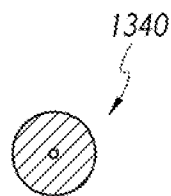

FIG. 57C

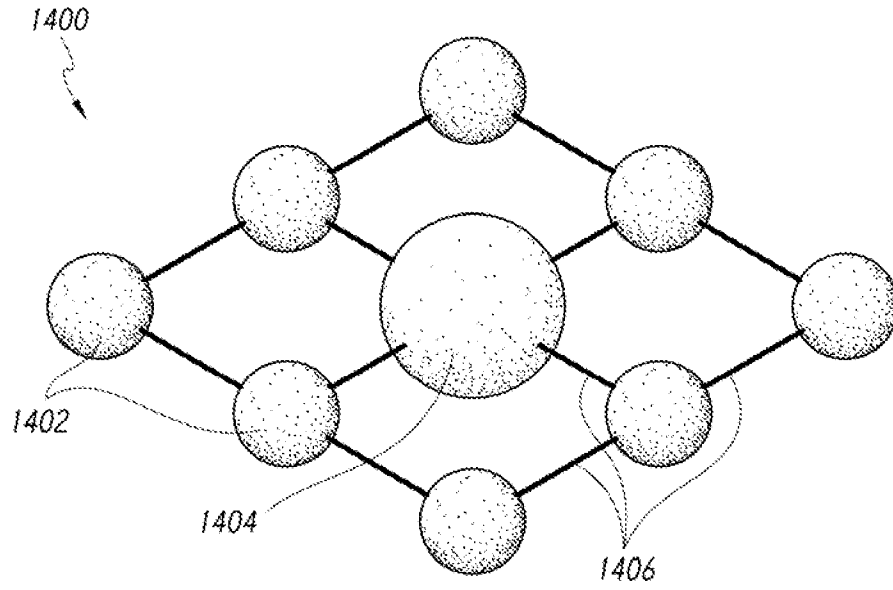

FIG. 58A

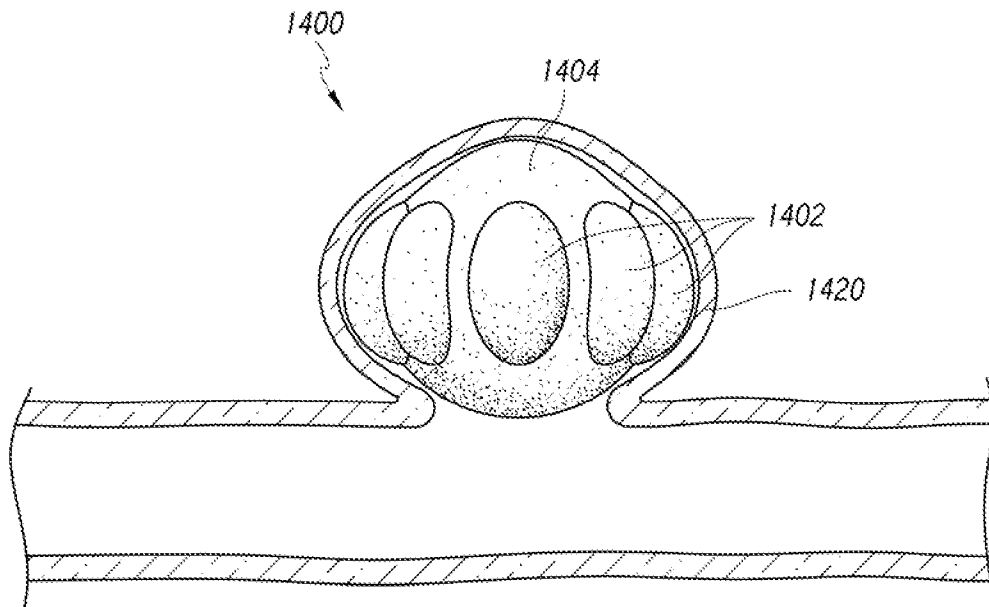

FIG. 58B

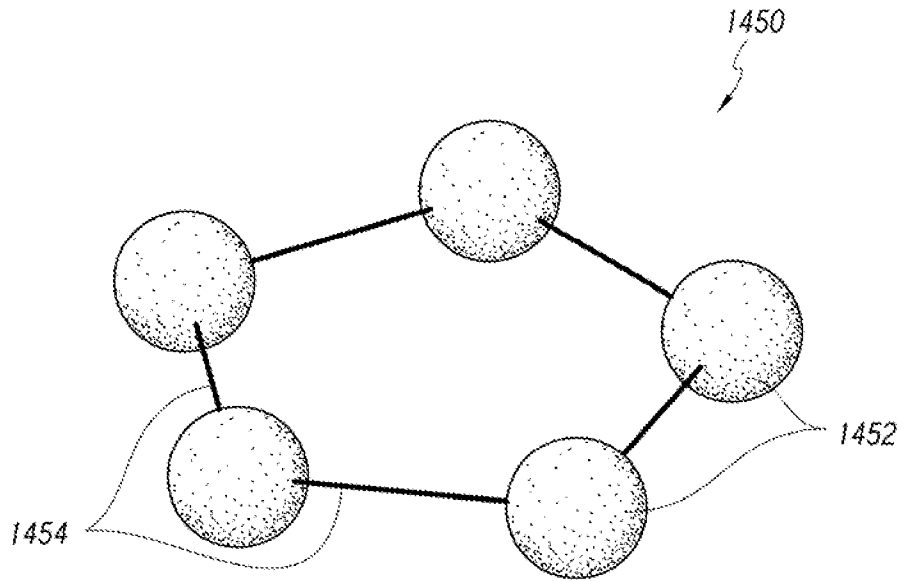

FIG. 59A

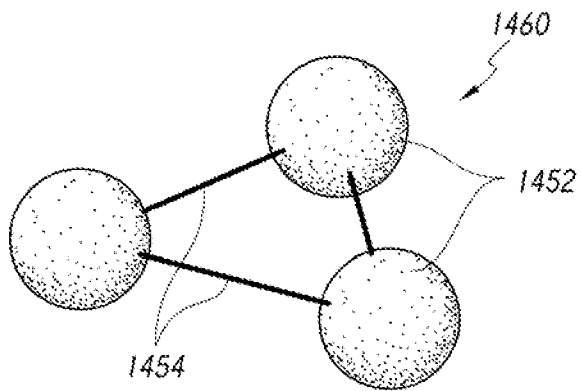

FIG. 59B

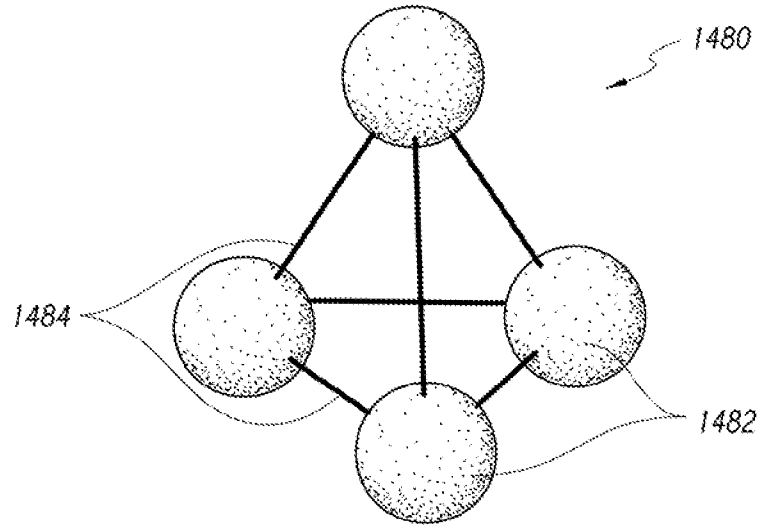

FIG. 60A

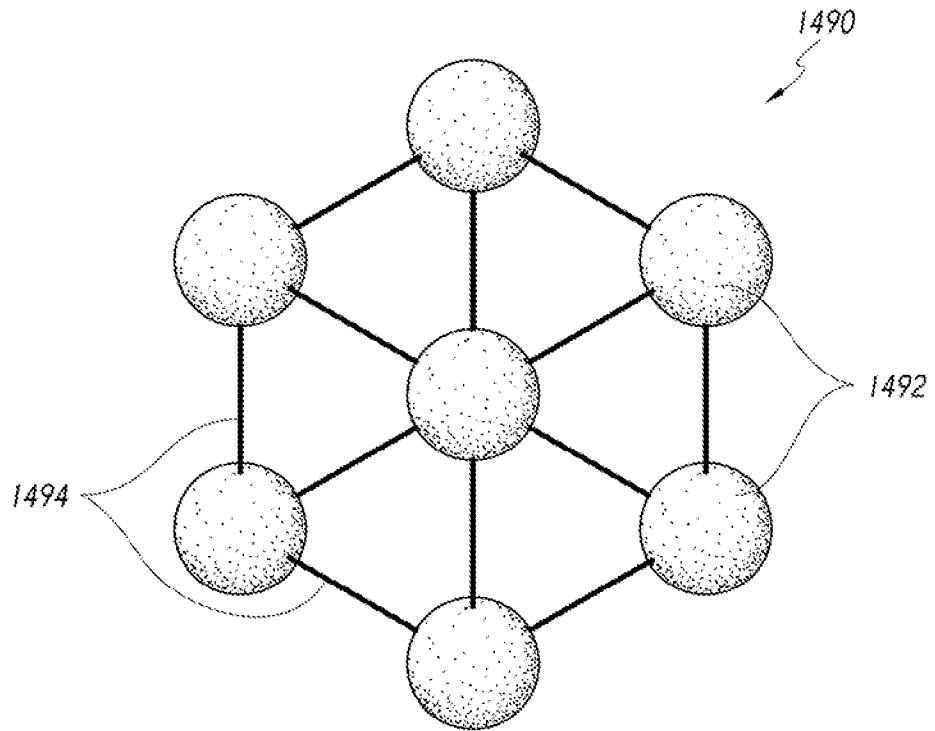

FIG. 60B

29/29

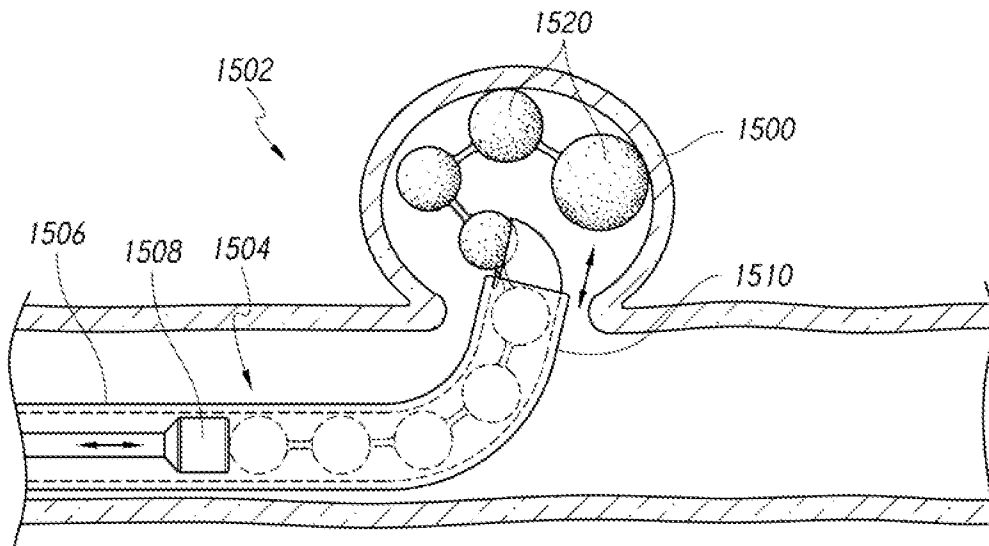

FIG. 61

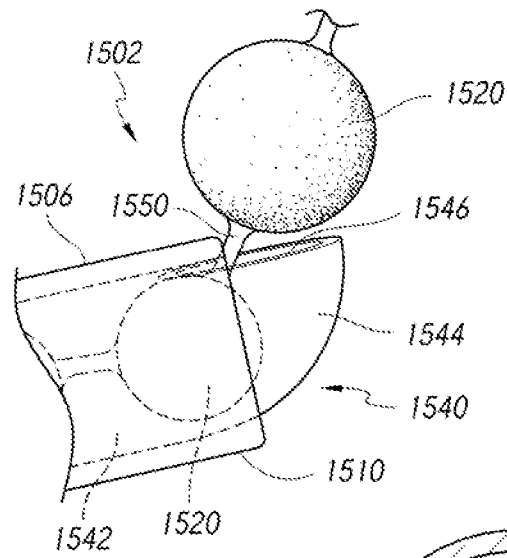

FIG. 62

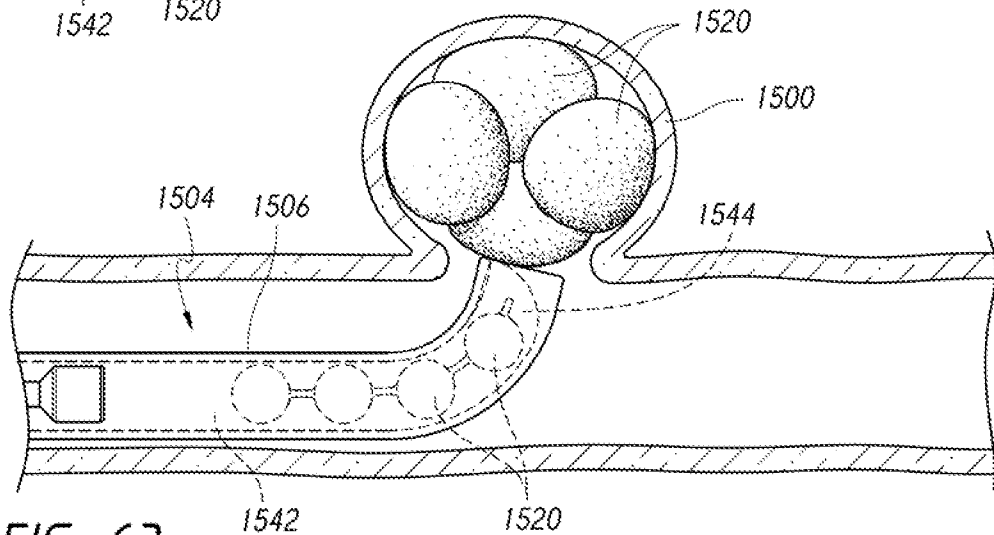

FIG. 63