

Dec. 8, 1942.

A. E. HARVEY

2,304,354

METHOD OF INCREASING THE HEIGHT OF STORAGE TANKS

Filed Feb. 1, 1940

5 Sheets-Sheet 1

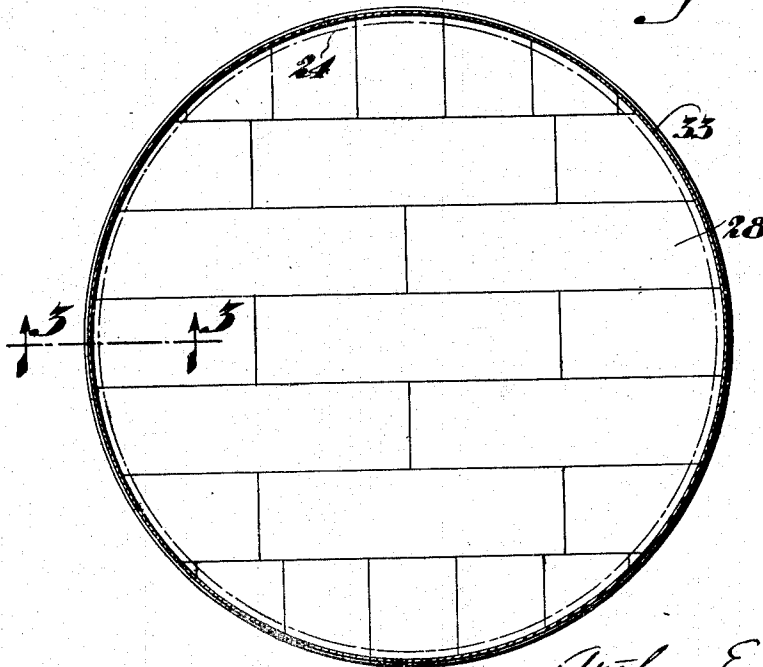
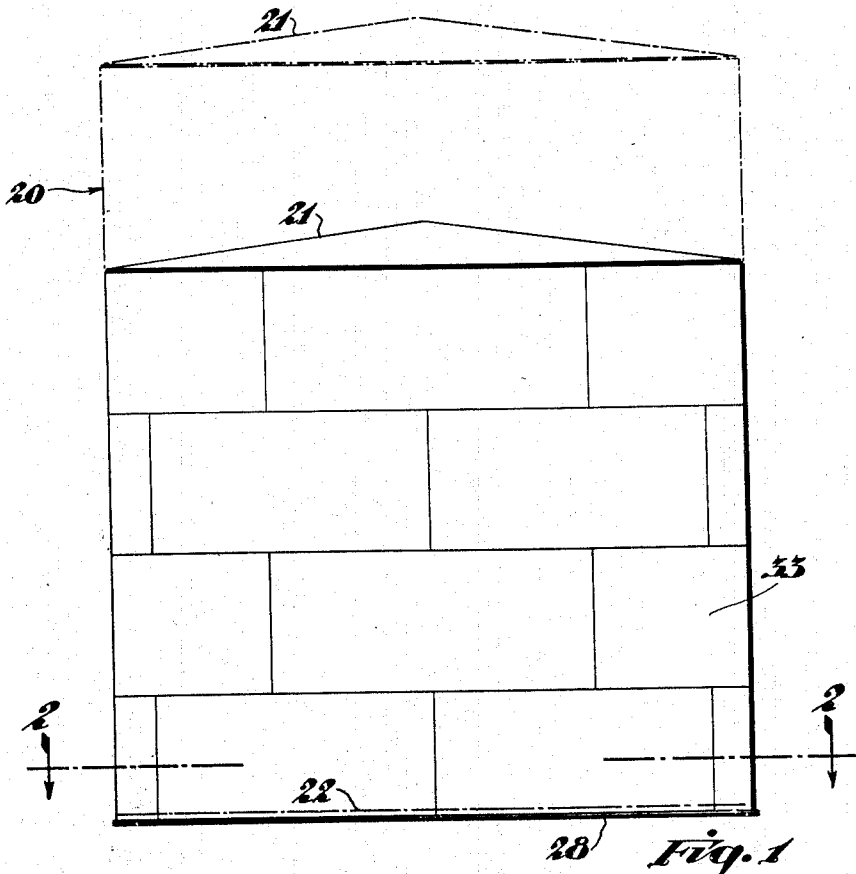

Fig. 2

INVENTOR.
Arthur E. Harvey
BY *Wood & Wood* ATTORNEYS

Dec. 8, 1942.

A. E. HARVEY

2,304,354

METHOD OF INCREASING THE HEIGHT OF STORAGE TANKS

Filed Feb. 1, 1940

5 Sheets-Sheet 2

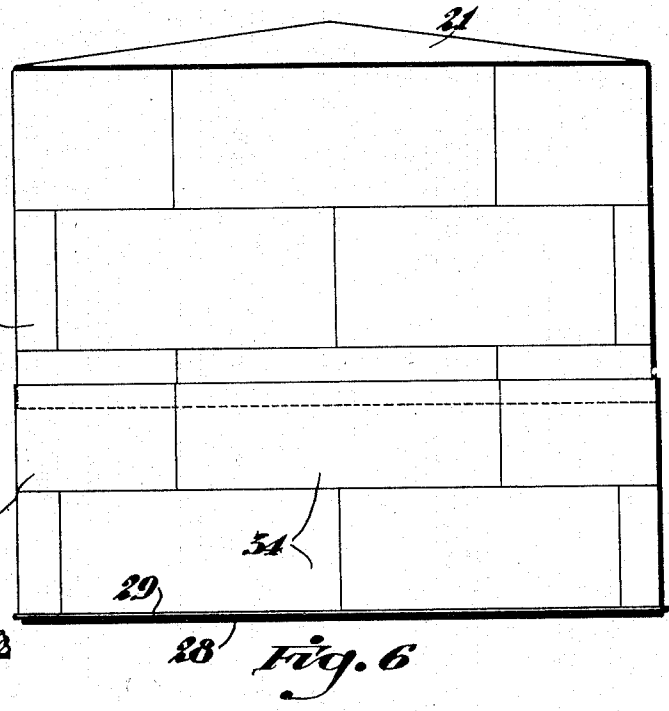
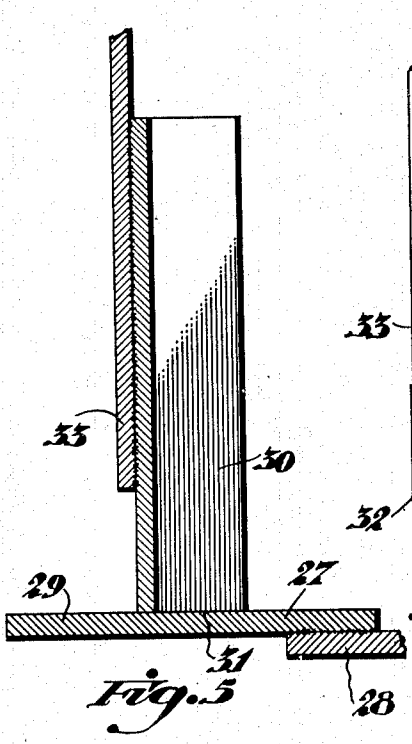
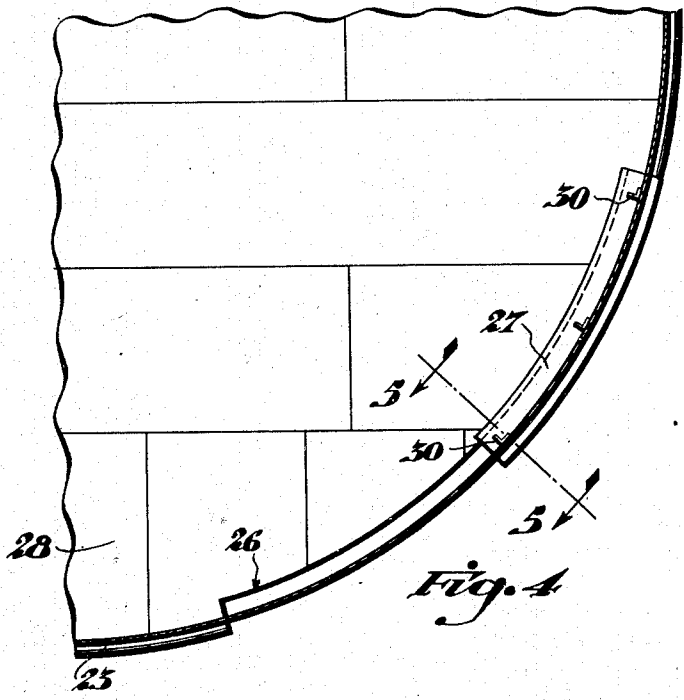
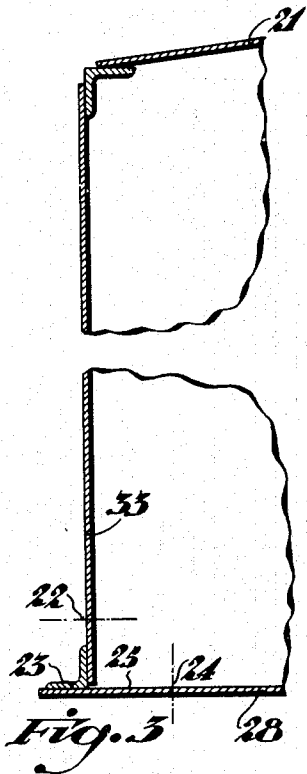

INVENTOR.
BY *Arthur E. Harvey*
Wood & Wood ATTORNEYS

Dec. 8, 1942.

A. E. HARVEY

2,304,354

METHOD OF INCREASING THE HEIGHT OF STORAGE TANKS

Filed Feb. 1, 1940

5 Sheets-Sheet 3

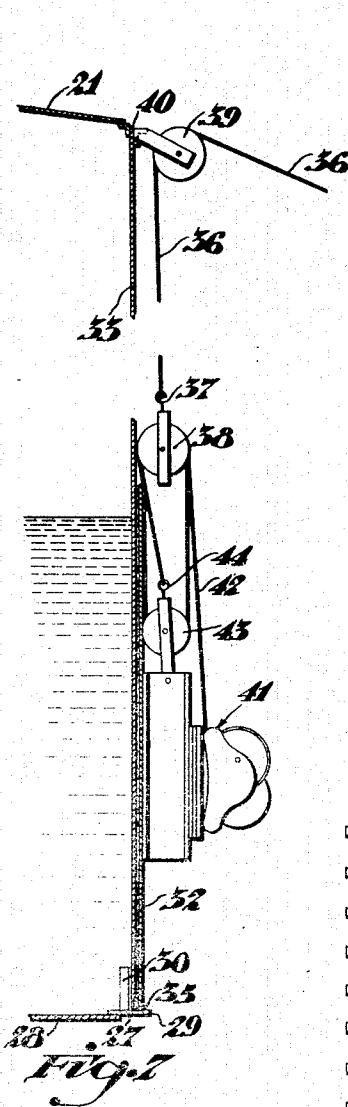

Fig. 7

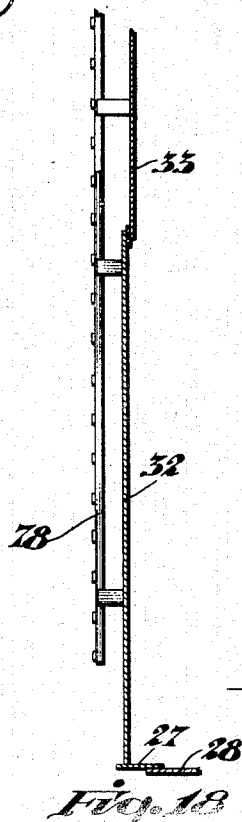

Fig. 18

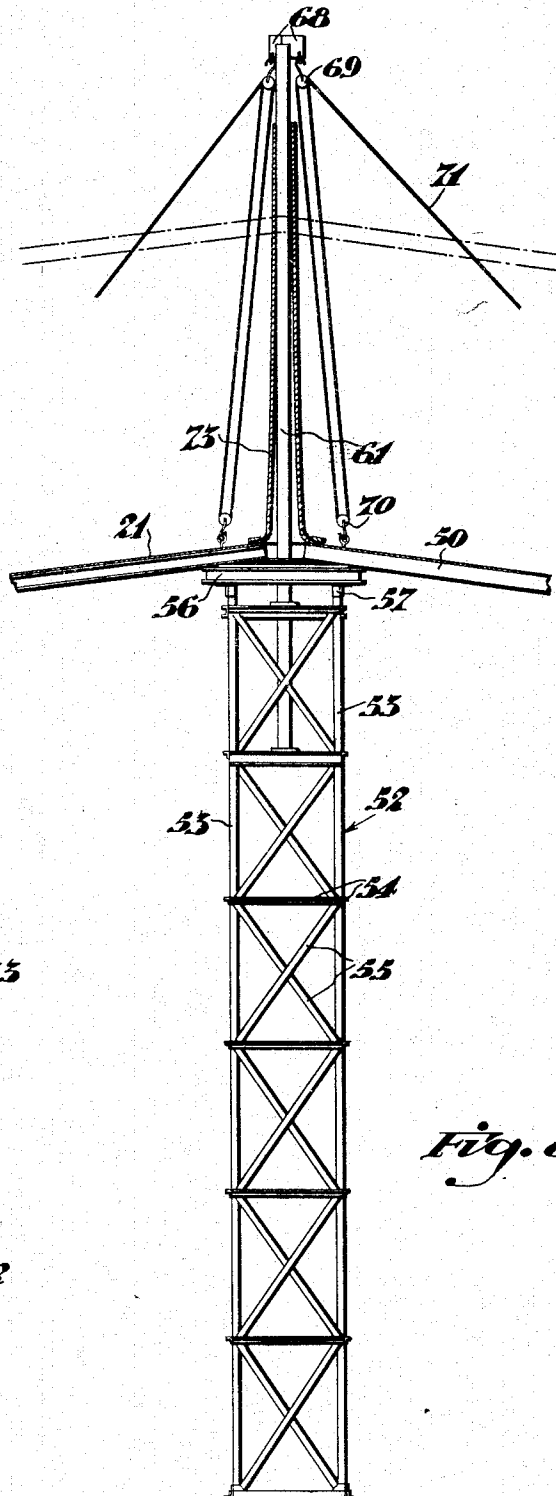

Fig. 8

INVENTOR.

BY *Arthur E. Harvey*
Wood & Wood ATTORNEYS

Dec. 8, 1942.

A. E. HARVEY

2,304,354

METHOD OF INCREASING THE HEIGHT OF STORAGE TANKS

Filed Feb. 1, 1940

5 Sheets-Sheet 4

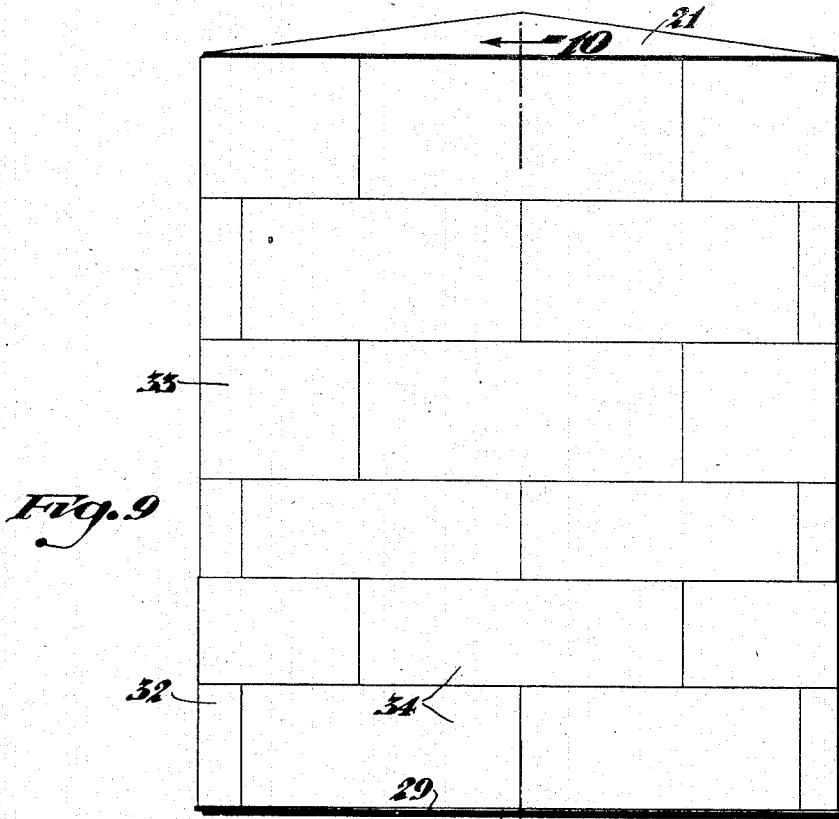

Fig. 9

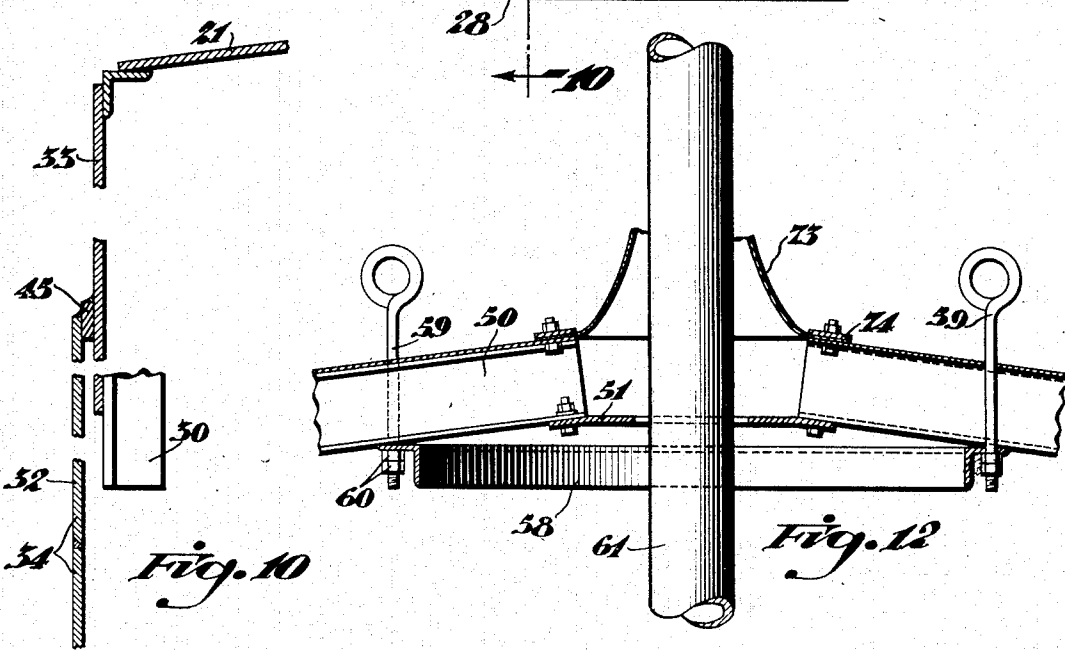

Fig. 10

Fig. 12

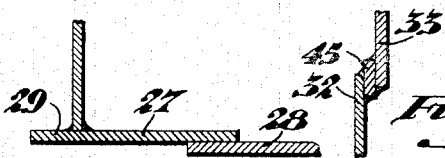

Fig. 11

INVENTOR.
Arthur E. Harvey
BY
Wood. Wood
ATTORNEYS

Dec. 8, 1942.

A. E. HARVEY

2,304,354

METHOD OF INCREASING THE HEIGHT OF STORAGE TANKS

Filed Feb. 1, 1940

5 Sheets-Sheet 5

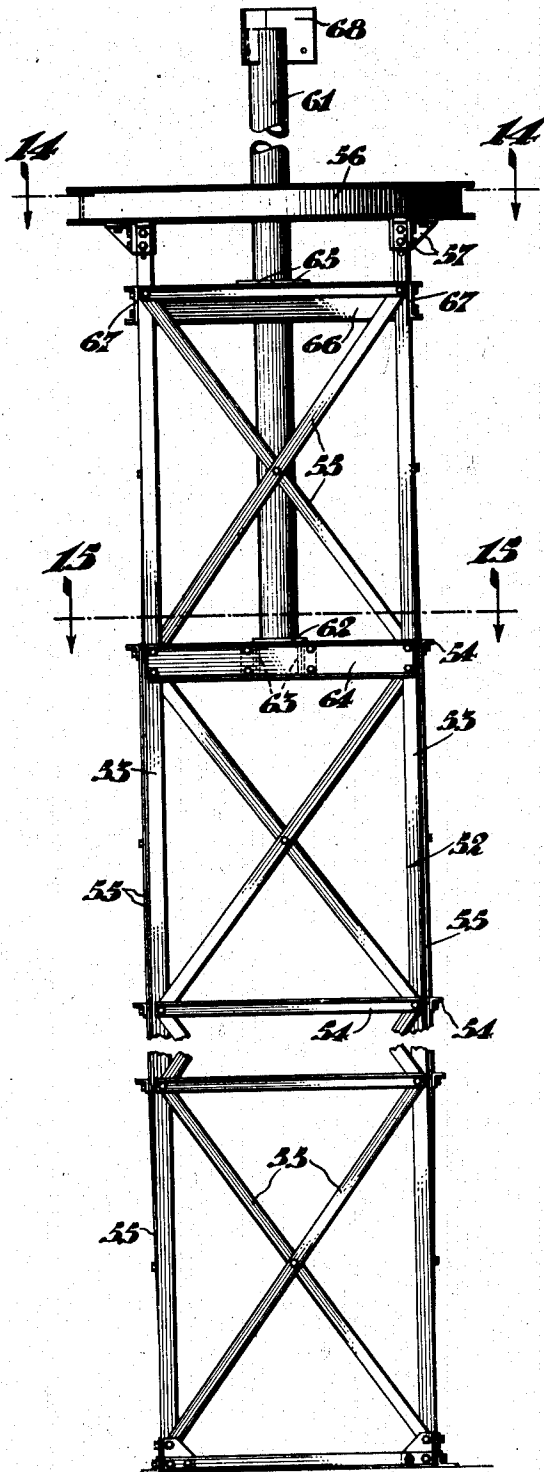

Fig. 13

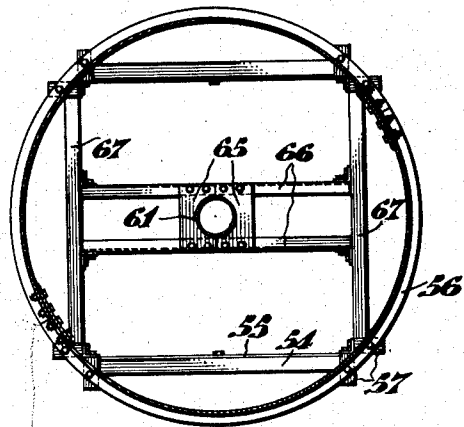

Fig. 14

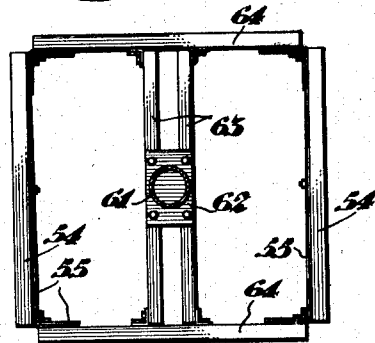

Fig. 15

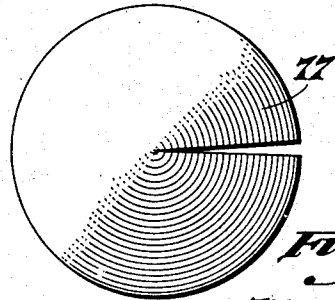

Fig. 16

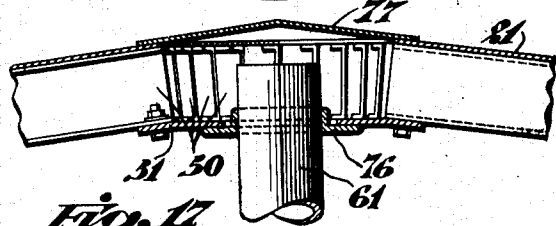

Fig. 17

INVENTOR.

BY

Arthur E. Harvey

Wood & Wood ATTORNEYS

UNITED STATES PATENT OFFICE

2,304,354

METHOD OF INCREASING THE HEIGHT OF STORAGE TANKS

Arthur E. Harvey, Cincinnati, Ohio, assignor to
The Stacey Brothers Gas Construction Com-
pany, Cincinnati, Ohio, a corporation of Ohio

Application February 1, 1940, Serial No. 316,812

4 Claims. (Cl. 29-148.2)

This invention relates to storage tanks for gasoline, oil, gas, etc., and is particularly directed to a method of increasing the height of a storage tank. Although the method may be utilized for increasing capacity, it has been developed primarily for the purpose of increasing the height of the tank.

Because of transportation facilities and for other commercial reasons, many storage tanks are located in zones which may be flooded. In the Ohio Valley flood which occurred in January 1937, considerable industrial property loss occurred because of the fact that tanks containing gasoline were raised from their foundations and the gasoline released upon the surface of the flood waters. In one instance the gasoline caught fire and considerable damage was done. In view of this, certain cities have passed ordinances relating to the height and maintenance of these storage tanks.

These ordinances specify that at least 30 per cent of the tank must extend above the maximum flood level. Also, they specify that the tank owners must, upon the approach of the flood waters, completely fill the tanks with water or gasoline or both. Due to the difference in specific gravity between water and gasoline, the tanks would have a tendency to rise even if completely filled with gasoline unless the tanks extended 30 per cent above the flood level. An empty tank will rise or tend to float if the water surrounding it is approximately a foot deep. Accordingly, the ordinances additionally specify that gasoline or water be added to any gasoline which may be in the tank to completely fill the tank. If this were not done, assuming for example that the tank was one-fourth filled, it would still rise if the water level reached the predetermined maximum of 70 per cent of the tank height.

Therefore, it was necessary to develop some efficient and inexpensive method of raising the tanks to increase the total height. It has been one object of the present inventor to provide an extremely efficient method of increasing the height of a storage tank without the necessity of completely dismantling the tank. As a result of this invention, it is practical to raise the tank shell substantially bodily from the ground and in the procedure to provide a lower wall section having a height corresponding to the increase necessary. Furthermore, it is possible to provide a base wall portion of heavier construction.

It is necessary to have the base portion of the wall of the tank of heavier plate construction for the purpose of resisting hydrostatic pressure and also for sustaining the added weight of the tank wall. Accordingly, it has been a further object of the present inventor to provide a method wherein the lower part of the tank is re-

placed as opposed to building an additional section on the top of the tank. This lower section can then be made of plates of greater thickness for resisting the added hydrostatic pressure and supporting the tank wall above it.

In the procedure of raising the tank, if it be one having a cone type roof, it has been a further object of the present inventor to develop a center pier arrangement for supporting the roof at the center and raising the same while the wall is being raised and for permanently supporting the roof after it has been elevated to the final position.

In general, the method involves the separation of the normal tank wall structure from its base and the building of a new and heavier lower section having a height slightly greater than the predetermined increase in height of the old tank wall. Thereupon water is introduced to a level about ten inches below the top of the new tank section. Air is introduced over the water and the old tank is raised under air pressure. In this operation, the tank is efficiently guided and maintained against tilting.

This method of reconstructing a tank by increasing its height, also has great value where increased capacity is wanted and the amount of available ground space is limited.

Other objects and certain advantages will be more fully apparent in the description of the drawings in which:

Figure 1 is a side view of a tank to be raised showing in dot and dash lines the position it is to assume when raised.

Figure 2 is a sectional view taken on line 2-2, Figure 1 detailing the tank structure at the bottom.

Figure 3 is a sectional view taken on line 3-3, Figure 2 showing in dot and dash lines the line along which the plates are to be cut.

Figure 4 is a fragmentary sectional view taken on or about the same line as Figure 2 but showing portions of the lower end of the tank wall cut away and a section of the support means inserted.

Figure 5 is a sectional view taken on line 5-5, Figure 4 illustrating the inserted support parts and the old tank wall resting in position prior to the raising operation.

Figure 6 is a side view of the tank with the new wall section built around it.

Figure 7 is a vertical sectional view taken diametrically through the wall of the tank showing one of the hoists for leveling the old tank as it is being elevated for connection at the top of the new section.

Figure 8 is a fragmentary view taken diametrically through the center of the tank showing the center support pier for a tank having a cone type top.

Figure 9 is a side view of the tank of Figure 6 showing the tank raised and the height appropriately increased.

Figure 10 is a sectional view taken on line 10-10, Figure 9 illustrating the sections tack welded together at their adjoining ends.

Figure 11 is a sectional view taken from Figure 10 showing the sections completely welded together and the lower end of the old tank cut off.

Figure 12 is a fragmentary sectional view taken diametrically at the center of the cone type roof during erection.

Figure 13 is a side view of the center pier.

Figure 14 is a sectional view taken on line 14-14, Figure 13.

Figure 15 is a sectional view taken on line 15-15, Figure 13.

Figure 16 is a top plan view of the cap for the roof.

Figure 17 is a diametrical sectional view showing the roof fastened in permanent position on the column or center post.

Figure 18 is a sectional view taken similar to Figure 7 and showing the ladder for access to the top of the tank.

Referring to the drawings, a tank to be raised has been shown in Figures 1 and 2. The outline of the tank when raised is shown in dot and dash lines at 20. For the purpose of showing the complete procedure, the drawings illustrate the method of raising a tank having a cone type roof indicated at 21 as opposed to an arcuate roof. In the case of a cone type roof, it is necessary to support the center of the tank while raising it.

After the tank has been emptied of gasoline or oil, all pipe lines are physically disconnected from the tank. The tank is then flushed out with water in order to remove all sediment. Steam is then delivered into the tank through an opening in the roof and exhausted through the shell manhole and other openings in the bottom. The purpose of the steam is to remove all inflammable and poisonous vapors from the tank. The steaming is continued some twelve to fourteen hours and the atmosphere in the tank is then tested to make sure that all gas has been removed. The testing is repeated two or three times a day during the procedure of raising the tank.

The tank wall is then cut away from the bottom in sections about nine feet long (Figure 4). The cutting is done by means of an acetylene torch. The tank wall is cut along a horizontal line 22, about three and one half inches above the tank bottom, that is, just above the curb angle 23. The bottom is cut on a circular line 24 about three and one half to four inches inside of the side wall. Radial cuts are made about every nine feet to remove the segments 25 leaving cut away portions generally indicated at 26. A new base plate section 27 of arcuate form is inserted after at least two of the nine foot sections have been cut away.

As indicated in Figure 5, the base plate section overlaps the old base 28 of the tank and extends outwardly beyond the tank wall as indicated at 29. These insert plates are lap welded to the old bottom plates and butt welded to each other. As each section is removed and another inserted, the shell is supported by welding the short vertical angles 30 to the inside of the tank. These angles constitute legs and rest upon the new or inserted base plates 27 as at 31. They are dis-

posed on about four foot centers, there being about three for each base plate insert.

As indicated in Figures 6 and 7, the new base wall portion 32 is built around the old shell wall 33. In the procedure shown, there are two rows of plates 34 in the new wall section. At this time, the lower edge of the new wall section is welded as at 35 to the extended inserted base plate sections 27. In assembling the new shell section sufficient clearness is maintained between the old tank wall and the new for preventing undue friction and drag when the tank is raised. Thereupon all manholes and fittings are cut off the old shell and welded to the new shell. The manhole and other openings in the old shell are then plugged with inserts which are welded in position.

The tank is filled with water to a level about 10 inches below the top of the new shell (Figure 7). All openings on the roof and upper part of the tank are sealed. Air is then pumped into the tank above the water which causes the old tank to move upwardly in its entirety. The old tank wall will move relative to the new tank wall in the same manner as the lift of a wet type holder will move relative to its tank. The old tank is guided within the new wall section against lateral movement.

In order that the tank will rise evenly, that is, without tipping and in order that it may be leveled when it reaches the elevation at which it is to be attached to the new tank wall, guy wires 36 are employed. The guy wire 36 extends from hooks 37, fastened to the axis of a hoist sheave 38, upwardly and over a pulley 39 having its axis fixed to the top curb 40 of the old tank section. The ends of the guy wire are anchored to the ground about 100 feet from the tank.

The hoist generally indicated at 41 is fixed to the outer wall of the new section by means of welding (Figure 7). The control cable 42 of the hand operated hoist, extends around the pulley 38 and around the pulley 43 fixed to the hoist thence back and around the pulley 38 and down to a fixed hook 44. Four or more of these hoists and guy wires are employed depending on the diameter of the tank. As the old tank moves upwardly due to air pressure, the cables 36 are permitted to play out as controlled by the hand hoist. A pressure gauge is used to determine the pressure in the tank. The pressure to be used is predetermined before the job is started. Allowance for friction is considered in this determination.

When the tank reaches the proper height approximately, the air going into the tank is throttled down to maintain enough pressure to float the tank. The final leveling is done entirely with the hand hoist guy wires. The tank may be leveled with each within a tolerance of one sixteenth of an inch.

With the tank leveled at the proper height, a filler and connecting ring 45 (Figure 10) is inserted between the old and new sections at the top of the new section. The rings of the two sections are then tack welded together. The air pressure is released and the water removed. The balance of the welding is thereupon completed. The bottom of the old shell is trimmed off within the tank and the tank is welded at intervals on the inside to the ring 45 and the ring to the new shell. The tank is then water tested for possible leaks.

It is pointed out that it is quite possible to build the new wall section around the old tank

before severing the old tank from its base. The new section may be secured to the base and the old tank then cut from its base from the inside. The method described herein is the preferred method, but the inventor obviously does not wish to be limited to it.

This is the entire procedure unless the tank has a cone type roof. The cone type roof is usually supported by radial rafters 50 (Figure 3) and a center pier. Before the raising operation is started, the normal center pier of the tank is removed.

A plate or circular disc 51 is bolted on the inner side of the peak of the roof coaxially with the tank center line. The rafters 50 are connected to this plate at their upper ends. A pier, generally indicated at 52, is disposed within the tank centrally thereof. This pier consists of angle iron uprights 53 at each corner tied together by angle iron side rails 54 at a plurality of elevations. Diagonal braces 55 strengthen the structure.

A supporting ring 56 formed of channel iron is mounted upon the top of the pier. It is fixed thereto by means of angle iron brackets 57. An angle iron ring 58 (Figure 12) is secured to the underside of the roof at its peak and is held in position by means of the eyelet rods 59 which extend upwardly through the roof and have nuts 60 on their lower ends engaging the ring 58. The center of the roof rests upon the ring 56 when in normal position prior to increase in height (Figure 8).

A center post 61 disposed axially of the tank, has its lower end mounted on a plate 62 (Figures 13 and 15). This plate is mounted on a pair of cross-channel rails 63 fixed to the side channels 64 of the pier. Just below the ring 56, the center post is held against lateral displacement by plates 65 encircling the post and fixed to channel iron rails 66 connected to the side channels 67. The post traverses the opening in the ring 51 and has sheave support plates 68 fixed radially in its upper end (Figure 8).

This post as indicated, extends above the position of the raised tank roof. Cable sheaves 69 are hung from these plates 68 by means of hooks. Cable sheaves 70 are attached to the eyelet rods 59 by means of hooks. Cables 71 extending around these sheaves are taken up as the roof is raised. The cables extend to hoists on the ground for this purpose.

In order to prevent an excessive loss of air around the center post, a canvas tube 73 (Figure 12) is utilized. The flared lower end of this canvas tube is fixed to the roof about the opening therein by means of a clamping ring 74. The upper end of the canvas is telescopically engaged with the post and is held in engagement therewith by means of wire wrapped around the canvas tube. This canvas tube may be slid along the pipe or may be long enough to invert as the roof moves up.

When the roof is in final position, the canvas tube is removed. The post 61 is cut off just below the top of the roof (Figure 17). A split boiler flange 76 is slipped into position around the post and against the underside of the ring 51. The post, flange and ring are welded together. The ring 58 and eyelet bolts are then removed whereupon the cap plate 77 is welded in position to seal the hole through which the post had projected. Thus it will be seen that

the temporary pier or scaffolding is made the permanent center pier for supporting the cone type roof. After the tank is completed, a ladder 78 (Figure 18) may be fixed in position.

Having described my invention I claim:

1. The method of raising a tank consisting of the steps of; severing the side wall from the base close to the base line, building a new wall section around the tank, attaching and sealing the new wall section relative to the base, filling the new tank section with water and delivering air into the space within the old tank above the water for raising the old tank to bring its lower edge to a position adjacent the upper edge of the new wall section, and thereafter securing the edges of these sections together.

2. The method of increasing the height of a tank comprising the steps of; severing the lower part of the wall from the base, temporarily supporting the tank wall on the base, building a new wall section around the tank wall slightly spaced therefrom, attaching the lower edge of the new wall section to the base, filling the new wall section with water, blowing air into the main tank section above the water for lifting the old tank, adjusting the elevated old tank so that its lower edge is disposed adjacent the upper edge of the new wall section, inserting a filler ring between the adjacent edges of the new wall section and the old tank, welding these parts together temporarily, exhausting the air and water, and, thereafter completing the welding of the ring, old tank, and new wall section together on the inside and outside of the tank.

3. The method of increasing the height of a tank comprising the steps of; removing sections of the lower part of the wall, curbing, and the bottom, replacing said sections after at least two have been removed with base sections secured to the base of the tank and extending beyond the outline of its wall, attaching legs to the tank wall for supporting the tank wall on the base sections, building a new tank section around the tank wall slightly spaced therefrom, welding the lower edge of the new tank section to the base sections, filling the new tank section with water, blowing air into the old tank above the water for lifting the old tank, restraining the raising movement of the old tank by control mechanism, adjusting the elevated old tank so that its lower edge is disposed adjacent the upper edge of the new tank section, inserting a filler ring between the sections and, welding these edges to the ring.

4. The method of increasing the height of a tank, comprising the steps of; severing the lower part of the wall of the tank from the base thereof, temporarily supporting the tank wall on the base, building a new wall section around the tank wall, welding the lower edge of the new wall section to the base, filling the new wall section with water, delivering air into the old tank section above the water for lifting the old tank section so that its lower edge is disposed adjacent the upper edge of the new wall section, supporting the new wall section relative to the old tank section with the edges in the aforesaid adjacent position, exhausting the air and water from the tank, and thereafter welding the adjacent edges of the new wall section and the old tank section together.

ARTHUR E. HARVEY.