



US 20080164729A1

(19) **United States**

(12) **Patent Application Publication**
Cavanaugh

(10) **Pub. No.: US 2008/0164729 A1**

(43) **Pub. Date: Jul. 10, 2008**

(54) **FOLD AWAY LAPTOP AND KEYBOARD TABLE**

Publication Classification

(76) Inventor: **Brian Cavanaugh**, Pittsburgh, PA (US)

(51) **Int. Cl.** *A47B 83/02* (2006.01)
(52) **U.S. Cl.** 297/162

Correspondence Address:
James Ray & Associates
2640 PITCAIRN ROAD
Monroeville, PA 15146

(57) **ABSTRACT**

A stowable tray assembly for upholstered sitting furniture includes an elongated storage compartment adaptable to installation either inside or outside an arm rest of a chair and a vertical telescoping post anchored inside the storage compartment. In addition, there is a means for releasably locking members of the vertical telescoping post in a fully extended position. A short horizontal support member is attached substantially perpendicular to the unanchored end of the vertical telescoping post, and a substantially horizontal tray support arm is pivotally attached to the free end of this horizontal support member. A tray table is rotatably attached substantially parallel to the axis of and along a portion of the tray support arm.

(21) Appl. No.: **12/008,363**

(22) Filed: **Jan. 10, 2008**

Related U.S. Application Data

(60) Provisional application No. 60/884,314, filed on Jan. 10, 2007.

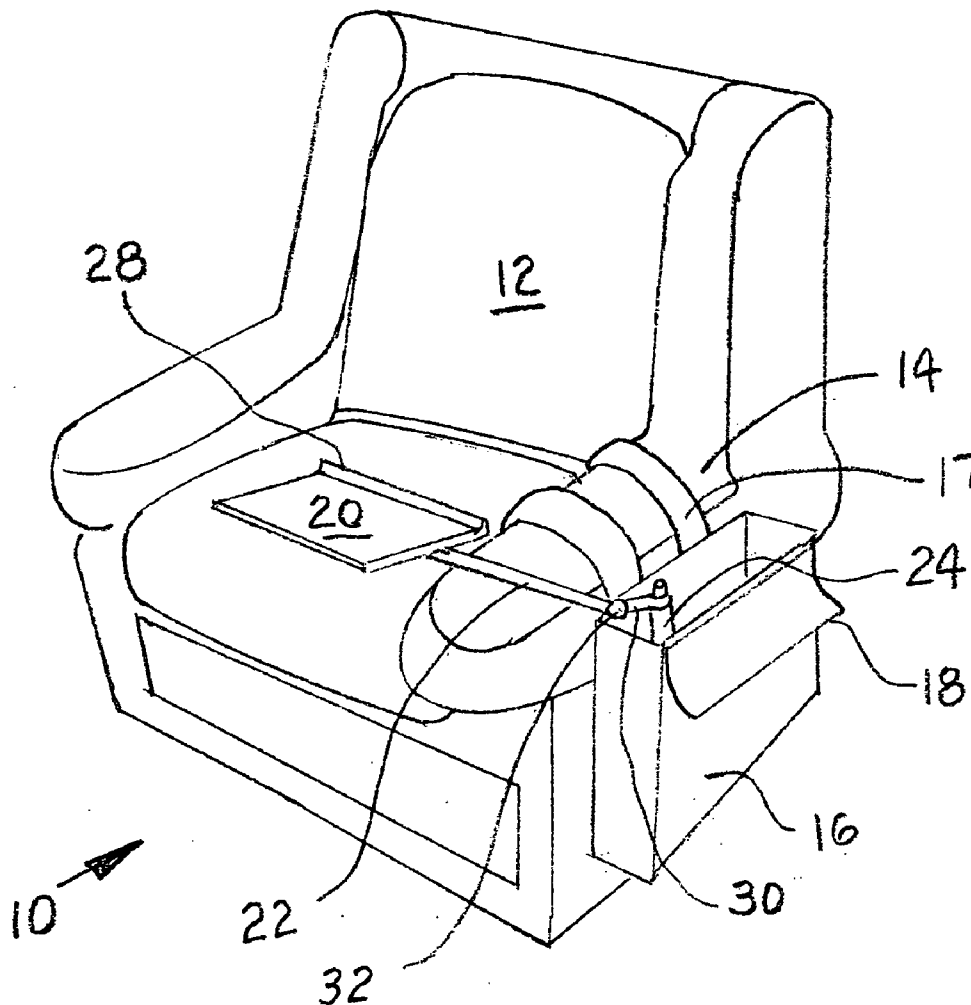

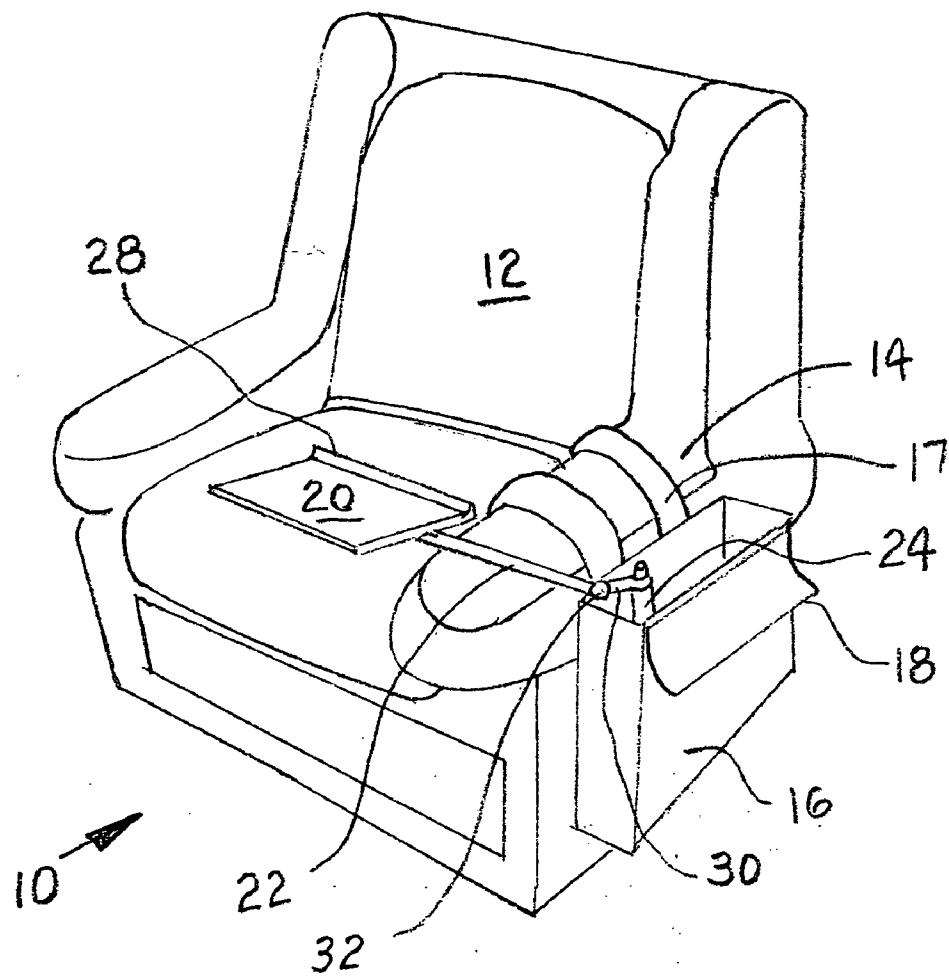

FIG. 1

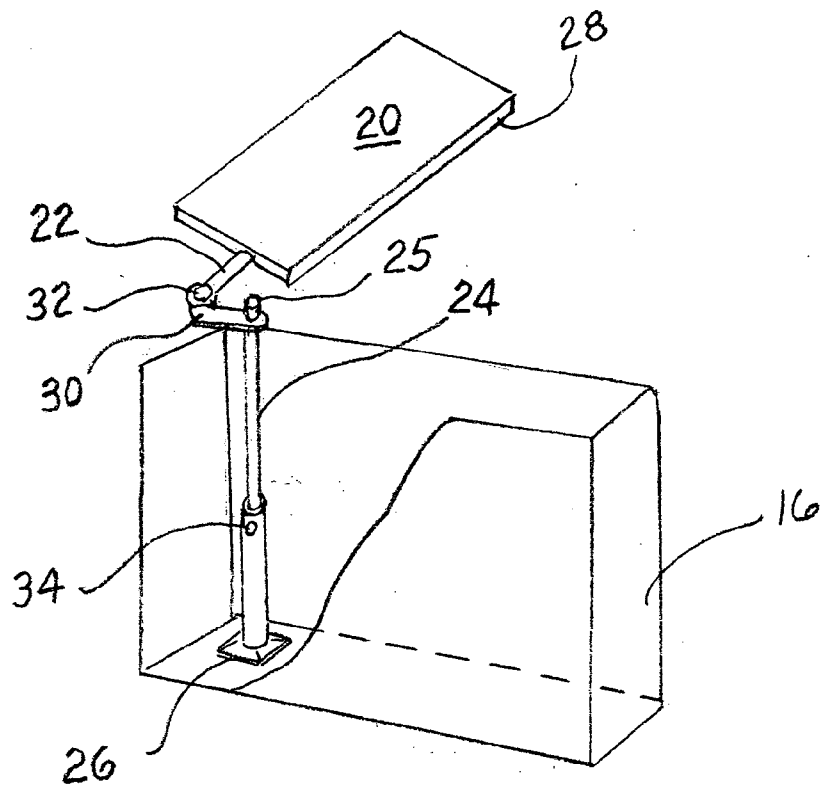

FIG. 2

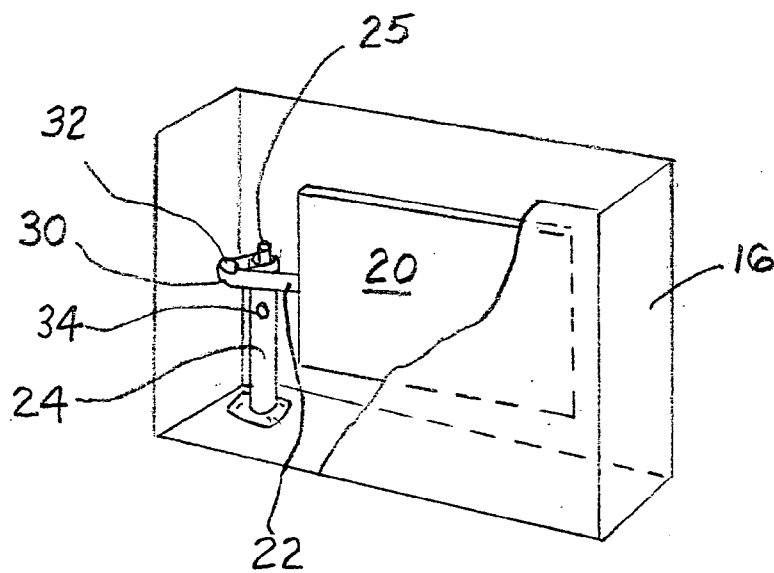

FIG. 3

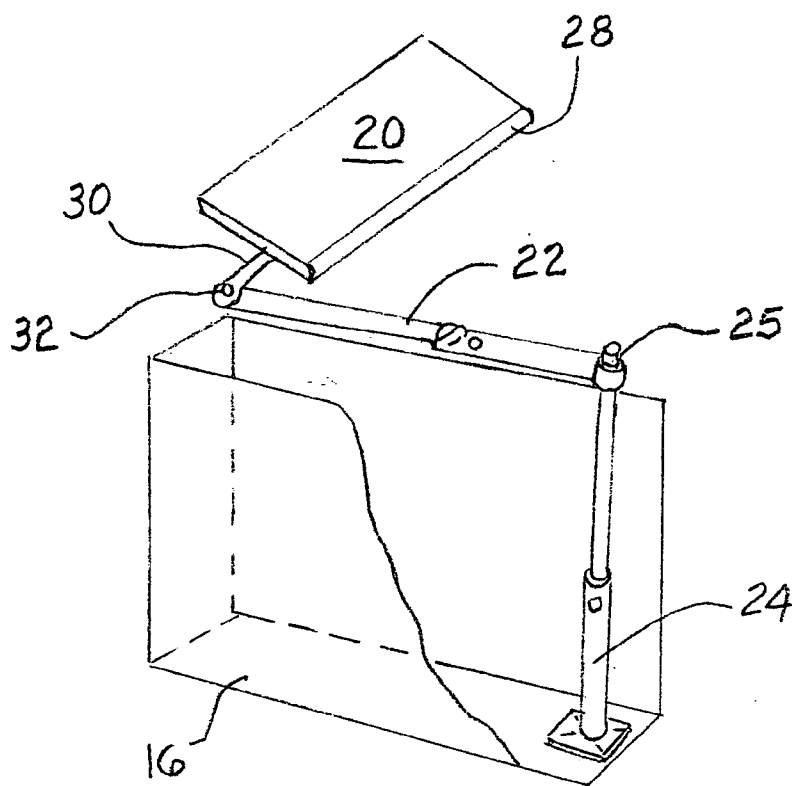

FIG. 4

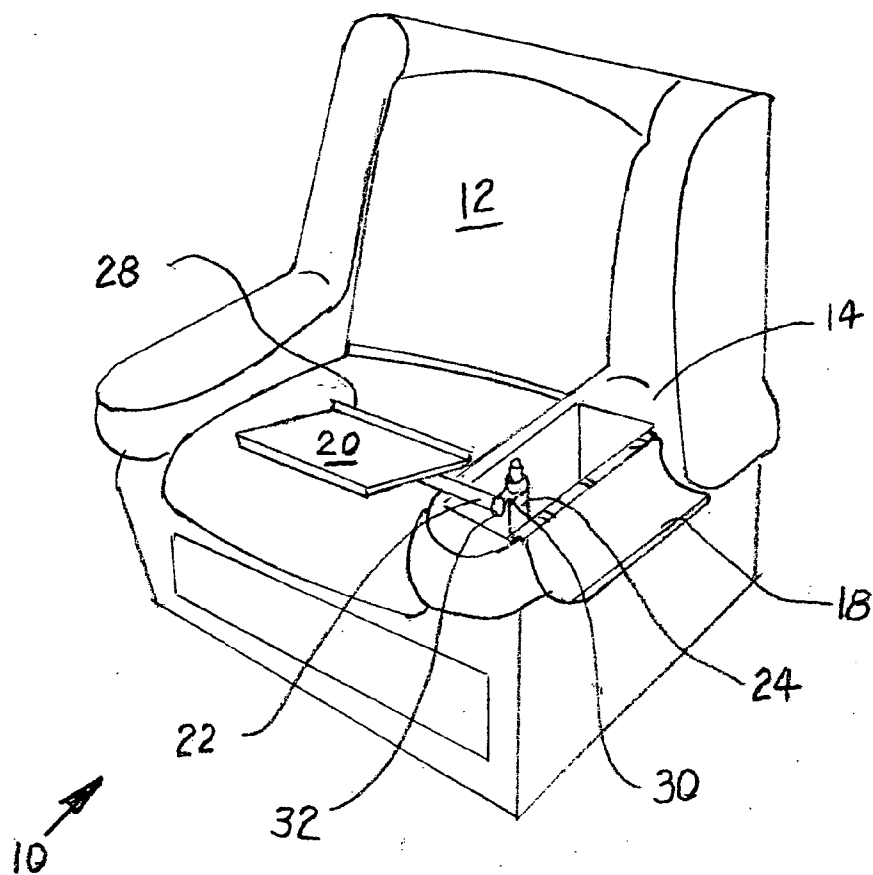

FIG. 5

FOLD AWAY LAPTOP AND KEYBOARD TABLE

CROSS REFERENCE TO RELATED APPLICATION

[0001] This patent application is related to and claims priority from U.S. Provisional Patent Application Ser. No. 60/884,314 filed Jan. 10, 2007.

FIELD OF THE INVENTION

[0002] The present invention relates, in general, to accessory tables for upholstered furniture and, more particularly, this invention relates to table trays for use while sitting in a chair, recliner, or couch, and stowable in a compartment inside or outside the furniture.

BACKGROUND OF THE INVENTION

[0003] Prior to the conception and development of the present invention, it has been generally known in the prior art to provide foldable tray systems with certain furniture. Notable among these are tray tables for bulkhead airline seats such as one described in U.S. Pat. No. 4,944,552. These have typically been for holding food and beverages. Now that it is common to use laptop computers without a wired connection, and a desktop computer can have a wireless keyboard and mouse, users may wish to avail themselves of more comfortable seating while using their computers.

[0004] Folding tray assemblies that store under a chair or couch when not in use are disclosed in U.S. Pat. Nos. 3,717,375 and 5,035,464. These may interfere with the operation of a recliner chair. U.S. Pat. No. 5,352,013 discloses a removable table for a recliner chair that stores as part of the leg rest. It appears that it would be cumbersome to remove and reinstall besides adding considerably to the weight of the leg rest that must be manually raised.

[0005] U.S. Pat. Nos. 5,050,929 and 5,630,642 disclose tray assemblies which can be stored in the arm rest of an upholstered chair. Both of these designs would require being built into the chair at the time of manufacture. Neither these two nor much of the similar prior art are tailored to computer users and offer generally just a flat horizontal surface.

SUMMARY OF THE INVENTION

[0006] The present invention overcomes deficiencies of the prior art by providing a stowable tray assembly for upholstered sitting furniture which includes an elongated storage compartment adaptable to installation either inside or outside an arm rest of a chair and a vertical telescoping post anchored inside the storage compartment. In addition, there is a means for releasably locking members of the vertical telescoping post in a fully extended position. A short horizontal support member is attached substantially perpendicular to the unanchored end of the vertical telescoping arm, and a substantially horizontal tray support arm is pivotally attached to the free end of this horizontal support member. A tray table is rotatably attached substantially parallel to the axis of and along a portion of the tray support arm.

[0007] In an alternative embodiment, the tray table can be releasably locked at any desired tilt angle. In addition, a remote release mechanism is provided for collapsing the vertical telescoping post.

OBJECTS OF THE INVENTION

[0008] It is, therefore, one of the primary objects of the present invention to provide especially comfortable seating with a table accessory for those working with laptop computers and keyboards.

[0009] Another object of the present invention is to provide a convenient table accessory for upholstered armchairs or sofas that will not substantially detract from the appearance of the seating furniture when the table is not in use.

[0010] Still another object of the present invention is to provide a chair tray system that is convenient to put into use but can also be easily repositioned for entering and exiting the chair without removing items on the tray.

[0011] Yet another object of the present invention is to provide a laptop or keyboard support tray for an upholstered chair that can tilt for ergonomic use.

[0012] An additional object of the present invention is to provide a tray accessory system which can be adapted to an existing chair or sofa.

[0013] In addition to the various objects and advantages of the present invention described with some degree of specificity above, it should be obvious that additional objects and advantages of the present invention will become more readily apparent to those persons who are skilled in the relevant art from the following more detailed description of the invention, particularly, when such description is taken in conjunction with the attached drawing figures and with the appended claims.

BRIEF DESCRIPTION OF THE DRAWINGS

[0014] FIG. 1 is a perspective view of a preferred embodiment of the present invention disposed on a recliner chair.

[0015] FIG. 2 is a partial isometric view, partially cut away for clarity, of the tray apparatus and storage compartment with the tray deployed for use.

[0016] FIG. 3 is a partial isometric view, partially cut away for clarity, of the tray apparatus and storage compartment with the tray in the stowed position.

[0017] FIG. 4 is a partial isometric view, partially cut away for clarity, of an alternative embodiment of the present invention.

[0018] FIG. 5 is a perspective view of the present invention deployed within the arm rest of a chair.

DETAILED DESCRIPTION OF A PRESENTLY PREFERRED AND VARIOUS ALTERNATIVE EMBODIMENTS OF THE INVENTION

[0019] Prior to proceeding to the more detailed description of the present invention it should be noted that, for the sake of clarity and understanding, identical components which have identical functions have been identified with identical reference numerals throughout the several views illustrated in the drawing figures.

[0020] Referring initially to FIG. 1, a preferred embodiment of the present invention 10 is presented with the tray apparatus deployed on a recliner chair 12. An elongated storage compartment 16 with a hinged lid 18 is shown hung over an arm 14 of the chair 12 with semi-rigid straps 17. Anchored

to the bottom of box 16 is a telescoping vertical post 24. A short arm 30 is secured perpendicular to the vertical post 24 and pivotally engaged with the tray support arm 22 at the opposite end with a commonly available joint 32. The underside of a support tray 20 is rotatably engaged with frictional resistance along the distal end of tray support arm 22. This allows the tilt of tray 20 to be adjusted for the comfort of the user while in use, and to be rotated into a vertical plane for stowing in the compartment 16. An optional locking means can be provided. When tray table 20 is tilted, an L-shaped lip 28 helps to prevent items from slipping off the tray 20.

[0021] FIG. 2 is a partially cut away isometric view of the support tray 20 deployed from a storage compartment 16, which could be either built into the arm of the chair, or hung over the side of the chair, not shown in this view. The telescoping vertical post 24 is fixedly secured to the bottom of the box 16 with a pedestal plate 26. A release mechanism 25 at the top end of post 24 disengages the protruding button 34 when the user wishes to stow the tray table into the compartment 16. A short arm 30 is attached perpendicularly to the vertical arm 24, and pivotally attached at joint 32 to tray support arm 22 at the opposite end. The pivoting allows the tray 20 to be swung into position in front of a user, or out of the way if the user wants to temporarily leave the chair. A key feature of the present invention is the ability to do this without removing items from the tray. The tray table 20 can be forcibly rotated around the axis of support arm 22 to obtain the desired tilt, or to position for storage. Alternatively, an adjustable tightening mechanism could be provided. To prevent items from slipping off of tray 20 when tilted, a lip 28 on the edge closest to the user is provided.

[0022] FIG. 3 illustrates with a partially cut away isometric view how the tray 20 is stowed away in the box compartment 16 when not in use. Both the tray 20 and support arm 22 would be pivoted about 180 degrees to position the support arm parallel to the longitudinal sides of the compartment 16. The tray table 20 would then be rotated around support arm 22 toward a vertical plane until it can be slid partially down into the compartment 16. The telescopic arm 24 would be collapsed by disengaging the release button 34 with aid of a release mechanism 25.

[0023] FIG. 4 presents an alternative embodiment of the present invention which is stowable in a rectangular box 16 that can be either built into the arm of a chair or attached alongside the arm of a chair. The telescoping vertical post 24 locks into the extended position by the action of a spring activated locking pin 34. An internal mechanism, activated by a spring-loaded button 25, releases the locking button 34 to permit shortening the vertical arm 24 for storing the tray assembly out of sight inside the box 16. The telescoping horizontal arm 22 can be shortened by depressing button 35. The tray support arm 30 rotates around a pivot joint 32. The tray 20 can be tilted by rotating on the support arm 22. An upward protruding lip 28 on tray 20 prevents items from slipping off.

[0024] FIG. 5 is a perspective view of an alternative embodiment of the present invention 10 built into the arm 14 of an upholstered chair 12, such as a recliner. A hinged lid 18

permits access to the tray 20 and the support assembly. A telescoping vertical arm 24 anchored to the bottom is extended to allow the tray 20 to be elevated out of the rectangular box 16. The tray support arm 22 is pivoted off the short arm 30 with a pivot joint 32 to position the tray 20 in front of the user. The tray 20 can be tilted by swiveling around the axis of support arm 22, and an L-shaped lip 28 disposed upward along the lateral edge closest to the user prevents items such as a keyboard or lap-top computer from slipping off. When the user wishes to get out of the chair, the tray 20 and support arm 22 can be pivoted away from the seat without removing items from the tray 20.

[0025] While a presently preferred and various alternative embodiments of the present invention have been described in sufficient detail above to enable a person skilled in the relevant art to make and use the same, it should be obvious that various other adaptations and modifications can be envisioned by those persons skilled in such art without departing from either the spirit of the invention or the scope of the appended claims.

What is claimed is:

1. A stowable tray assembly for upholstered sitting furniture comprising:

- a) an elongated storage compartment to be disposed one of inside and outside an arm rest of said upholstered sitting furniture, wherein said storage compartment defines a box with side and end panels;
- b) a vertical telescoping post anchored inside said storage compartment proximal one of said compartment end panels, wherein said vertical telescoping post includes at least two coaxial sliding tubular members;
- c) a means for releasably locking said tubular members of said vertical telescoping post in a fully extended position;
- d) a horizontal support member attached substantially perpendicular to unanchored end of said vertical telescoping post;
- e) a substantially horizontal tray support arm pivotally attached to said horizontal support member; and
- f) a substantially planar tray rotatably attached substantially parallel to axis of and along a portion of said tray support arm.

2. The stowable tray assembly, according to claim 1, wherein said substantially planar tray includes a protruding lip along at least one lateral edge of said planar tray.

3. The stowable tray assembly, according to claim 2, wherein said protruding lip on said one lateral edge is disposed in a position facing a user.

4. The stowable tray assembly, according to claim 1, wherein said elongated storage compartment includes a pivoting lid hinged along upper outer lateral edge of said compartment.

5. The stowable tray assembly, according to claim 4, wherein said pivoting lid forms a part of such arm rest.

6. The stowable tray assembly, according to claim 1, wherein said substantially planar tray includes a releasable locking means for holding a desired tilt angle.

7. The stowable tray assembly, according to claim 1, wherein said horizontal support member is telescopic.

8. The stowable tray assembly, according to claim 1, wherein said vertical telescoping post further includes a remote means at top of said post for disengaging said tubular members.

9. The stowable tray assembly, according to claim 1, wherein said tray assembly includes means engageable with said storage compartment for connecting said storage compartment outside such arm rest.

10. The stowable tray assembly, according to claim 9, wherein said means for connecting said storage compartment includes at least one strap member.

11. The stowable tray assembly, according to claim 1, wherein said means for releasably locking members includes a pin member engageable in an aperture disposed through a side wall of said telescoping post.

* * * * *