

(19) World Intellectual Property
Organization
International Bureau



(43) International Publication Date
8 January 2004 (08.01.2004)

PCT

(10) International Publication Number
WO 2004/003934 A1

(51) International Patent Classification⁷: G21F 7/00, 3/00

(21) International Application Number:
PCT/SE2003/001025

(22) International Filing Date: 18 June 2003 (18.06.2003)

(25) Filing Language: English

(26) Publication Language: English

(30) Priority Data:
0202031-1 1 July 2002 (01.07.2002) SE
60/393,106 3 July 2002 (03.07.2002) US

(71) Applicant (for all designated States except US): ELEKTA
AB [SE/SE]; S-103 93 Stockholm (SE).

(72) Inventors; and

(75) Inventors/Applicants (for US only): PUUSEPP, Thomas
[SE/US]; 2019 Westbourne Way, Alpharetta, GA 30022
(US). LUNDBERG, Rolf [SE/SE]; Repslagaregatan 34,
S-582 22 Linköping (SE).

(74) Agent: AWAPATENT AB; Box 53, S-826 22 Söderhamn
(SE).

(81) Designated States (national): AE, AG, AL, AM, AT, AU, AZ, BA, BB, BG, BR, BY, BZ, CA, CH, CN, CO, CR, CU, CZ (utility model), CZ, DE (utility model), DE, DK (utility model), DK, DM, DZ, EC, EE (utility model), EE, ES, FI (utility model), FI, GB, GD, GE, GH, GM, HR, HU, ID, IL, IN, IS, JP, KE, KG, KP, KR, KZ, LC, LK, LR, LS, LT, LU, LV, MA, MD, MG, MK, MN, MW, MX, MZ, NI, NO, NZ, OM, PH, PL, PT, RO, RU, SC, SD, SE, SG, SK, SL, TJ, TM, TN, TR, TT, TZ, UA, UG, US, UZ, VC, VN, YU, ZA, ZM, ZW.

(84) Designated States (regional): ARIPO patent (GH, GM, KE, LS, MW, MZ, SD, SL, SZ, TZ, UG, ZM, ZW), Eurasian patent (AM, AZ, BY, KG, KZ, MD, RU, TJ, TM), European patent (AT, BE, BG, CH, CY, CZ, DE, DK, EE, ES, FI, FR, GB, GR, HU, IE, IT, LU, MC, NL, PT, RO, SE, SI, SK, TR), OAPI patent (BF, BJ, CF, CG, CI, CM, GA, GN, GQ, GW, ML, MR, NE, SN, TD, TG).

Published:

— with international search report

For two-letter codes and other abbreviations, refer to the "Guidance Notes on Codes and Abbreviations" appearing at the beginning of each regular issue of the PCT Gazette.

(54) Title: A MOBILE BUILDING UNIT AS WELL AS A BUILDING AND A METHOD FOR CONSTRUCTING THE BUILDING

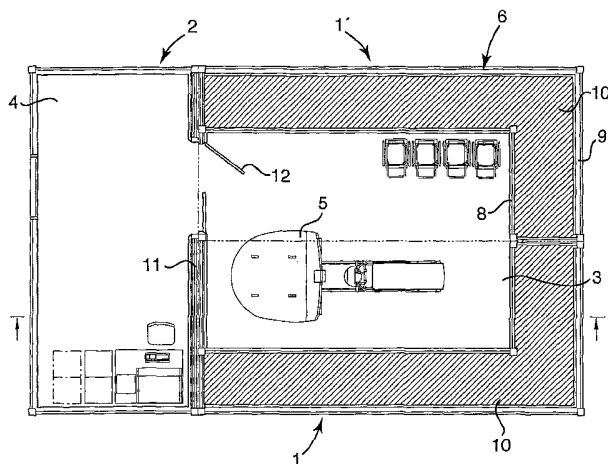

(57) Abstract: The invention relates to a mobile building unit which is assembled to a building including at least one room (3) enclosed by walls (6), a roof (7) and a floor (12) for accommodating radiating equipment (5) and for treatment, therapy or diagnosis by means of ionizing radiation. The walls, the roof and floor of said building (1, 1') serve as a radiation shielding barrier for preventing radiation at health-impairing levels from escaping to the outside of the building structure. At least two of the walls and the roof of the building, has the form of a double walled structure comprising an inner (8) and an outer (9) partition element with a space (10) therebetween. The building also has a filling inlet through which the space is fillable with a fillable material, in order to reduce weight and facilitate transportation of the assembled building with the space in an emptied state, and to allow filling of the space with the fillable material once the building is located at a site, where it is to be used, to provide a radiation shielding barrier with a sufficient shielding capacity. The invention also relates to a method for constructing the same.

WO 2004/003934 A1

A MOBILE BUILDING UNIT AS WELL AS A BUILDING AND A METHOD
FOR CONSTRUCTING THE BUILDING

Field of the invention

The present invention relates to a mobile building unit including at least two walls, a roof and a floor, which is movable to an operating site and assembled there to form a building including at least one room defined by at least four walls, a roof, and a floor.

The invention also relates to a building including at least one room, enclosed by walls, a roof and a floor, for accommodating radiating equipment for treatment, therapy or diagnosing by means of ionizing radiation, wherein the walls, the roof and the floor of said building serve as a radiation shielding barrier for preventing radiation at health-impairing levels from escaping to the outside of the building structure.

The invention also relates to a method for constructing a building including such a room.

Background of the invention

Installation of radiating equipment, such as equipment for X-ray imaging, radiation surgery or therapy, or radiation sterilization of various products such as e.g. foods or material, is elaborate and time-consuming since the radiation generating equipment must be enclosed by a radiation shielding so that only the patient or the product being treated, is exposed to the high radiation levels necessary. The radiation shielding is normally accomplished by constructing the walls, roof and floor of the room, where the equipment is located, of very thick concrete, often in the order of about 500 mm or thicker. For an existing building this necessitates an extensive reconstruction. Additionally, since the equipment often is very heavy, e.g. equipment for radiation surgery weighs

about 20 tons, it may require reinforcement of the floor structure.

An alternative method is to cover the walls, roof and floor with plates of a material with high density, e.g. lead. However, this will be more costly than by using concrete and at least equally heavy.

Consequently, the radiation equipment normally is accommodated in a separate building, either as a completely freestanding building or connected to another building, such as a main building of a hospital. However, constructing a completely new building of concrete is elaborate and time-consuming and involves planning, foundation work, concrete casting of the building structure, installation of water pipe system, electrical system, communication system, temperature control system and ventilating system, inner and outer covering of the walls, roof and floor including insulation if any, as well as installation of the radiation equipment in the completed building. Altogether this is a process which often is extended over a period of six months or more.

Consequently, there is a long implementation time from the decision to acquire new equipment to being able to put it into operation. This is of course a big disadvantage since the radiation equipment and the specially designed building, ties up a large amount of capital and it is naturally desirable to have a rapid yield on invested capital. From the buyers point of view it is therefore of great advantage if the equipment can be put into operation as soon as possible to gain benefit of the investment.

Another disadvantage with such a specially constructed radiation shielded building is that it is not a flexible solution which can easily be re-allocated to another location, altered in its size or used for another purpose. On the contrary it is very difficult, or even impossible, to move a building of that size with such thick concrete walls and roof, and it is also difficult

to rebuild or expand the building, e.g. for another application or just to expand the space for the same or similar activity, if that is desirable. The only remaining alternative in practice when it is desirable to
5 change the function or location, is therefore often to demolish the building.

Summary of the invention

One object of the invention is to provide a mobile
10 building unit which easily and quickly can be assembled to serve as a radiation shielded building for accommodating radiating equipment.

The invention also refers to a building with essentially the same object as above.

15 The invention also refers to a method which facilitates constructing of a building adapted for accommodating radiating equipment.

Accordingly, the invention is based on the understanding that the above-mentioned objects can be achieved
20 by constructing the building in form of one or more mobile building units, wherein at least two of the walls and the roof of the building units are designed with an outer and an inner partition element with a space or an accommodation between the partition elements, adapted to
25 be filled with a fillable radiation shielding material.

Thanks to the fact that the fillable material can be added after the building units are already in place at the operating site, the units are easily transportable in an empty state. Therefore, the units can be manufactured
30 at an industry plant or construction site, remote from the final location or operating site of the building, and thereafter transferred to the operating site and assembled there.

During manufacturing of the units, the foundation
35 work at the operating site may be prepared so that when both the foundation work and the units are completed, the

units are transferred to the operating site and assembled.

When the assembling is finished, the spaces between the inner and outer partition elements may be filled with
5 any fillable material capable of providing radiation shielding when contained within the spaces between the partition elements in the building units. Suitable filling material include liquids, e.g. water, or a particulate or grain shaped solid bulk material, e.g. sand.

10 By letting the fillable material form an essential or a main part of the radiation shielding barrier between the radiation equipment and the environment, the units will have a comparatively low weight in a state where the spaces in the walls, the roof and possibly the floor are
15 unfilled. This enables transport of the units by truck, train or boat from the construction site to the operating site. Not until the units are installed and assembled at the operating site, the radiation shielding is arranged by filling the fillable material in the spaces in the
20 building units.

This also enables removal or re-allocation of the building, if so desired, by easily emptying of the fillable material and thereafter loading the building units on a carriage.

25 The radiation shielded building may be formed in one single unit but generally, the required size will make it advantageous to assemble the building by connecting two or more mating units to each other. In a hereafter shown and described preferred embodiment of the invention, the
30 radiation shielded building is composed of two mating, "container-like" building units forming a radiation shielded treatment room for treatment of a patient. The building also comprises an operator room accommodated in a third building unit, but that third building unit need
35 not be radiation shielded since no radiation is generated in the operator room. However, the wall between the operator room and the treatment room must of course be ra-

diation shielded. In the preferred embodiment this has not been accomplished by a fillable material in a space in the wall, but through a sandwich wall structure with absorbing metal plates, e.g. steel plates.

5 The width of the space in the walls, roof and possibly the floor is dependent on for instance the type of radiation, the radiation intensity and the type of material used as a fillable material. In the exemplified embodiment, water is used as a fillable material in a
10 building adapted for radiation surgery with gamma-radiation and in that case a space of between 500 to 1500 mm is generally sufficient.

 When using water as a fillable material, the spaces in the walls, roof and possibly the floor of the building
15 preferably are formed as closed spaces or "tanks" to prevent leakage or evaporation of the water. In the preferred embodiment, a thin layer of insulation is arranged on the inside as well as the outside of the walls and
20 roof. To ensure a comfortably indoor climate and to prevent freezing of the water to ice during winter, the water in the spaces may be connected to a temperature controlling system for warming the water during the cold
season and possibly cooling the water during the warm
season.

25 The water in the partition spaces may also be automatically monitored, by a water levelling system, to eliminate the risk of unintentional lowering of the water level due to leakage, evaporation or the like, and resulting deteriorated radiation shielding protection.

30 In the preferred embodiment the partition elements in the walls and roof are made of sheets of steel applied on a system of steel beams. To prevent corrosion an additive preferably is added to the water. However, it would be possible to make the partition elements of other materials, such as for example concrete, possible in combination
35 with plastic film to ensure impermeability to water.

In the preferred embodiment of a building, three of four walls and the roof include waterfilled spaces. The wall between the treatment room and the operator room does however not include a waterfilled space, since the radiation from the radiation surgery equipment, for which the building is adapted, is low in the area behind the equipment and therefore the necessary radiation shielding can be achieved by a comparatively thin layer of steel sheets. Neither the floor is provided with a waterfilled space since the building is adapted to be placed on a foundation in form of a concrete slab which will provide for the necessary radiation shielding. It is to be understood, however, that a building according to the invention may be constructed with spaces filled with various materials in all of the boundary elements defining the building.

When using a pulverous or granular material, such as sand, instead of a liquid, as a radiation shielding material, the walls, roof and possibly the floor of the building may have another design. Among other things the spaces need not be hermetical closed to prevent evaporation. Generally, the inlet as well as the outlet openings need to be of a larger dimension since a pulverous or granular material, as a rule, are not possible to be pumped, but must be poured or blown into and out from the spaces. The outlet openings may, for instance, be in form of lids in the bottom portions of the walls to allow emptying.

However, as a rule it is more advantageous to use a liquid as a fillable material since then it is easier to monitor unintentional lowering of the filling ratio of the material, and to prevent unintentionally formation of air pockets, with deteriorated shielding capacity as a result. Naturally, water is preferred as a fillable material as it is a low cost material which is easily accessible in most places.

When assembling the building of two or more building units, it is important that all connection joints between different units will be performed in a sealed manner to prevent radiation from escaping to the environment. This is suitably ensured by forming all connection joints in a labyrinth form.

With a building according to the invention, it is possible to start the construction of the building structure essentially simultaneously with the foundation work. The building structure is preferably constructed at an industry plant and in the preferred embodiment the building is assembled by three separate building units. Two units forming the radiation shielded treatment room and one unit forming a non-shielded operator room. Though preferred, but not necessary, all units are assembled at the industry and are provided with electrical system, communication system, temperature control system, ventilating system, as well as inner and outer covering of the walls, roof and floor including insulation if any. However, as an alternative, some of the installation may be performed at the operating site if that is desired. That is the case for instance with the installation of the radiation equipment, which often is both heavy and sensitive, and will normally be postponed until the building is situated at the operating site. The same applies normally for computers and other sensitive equipment. Of course such sensitive equipment may also be preinstalled if care is taken during transportation and handling.

In the preferred embodiment the building thereafter is disassembled at the constructing site, into the separate units and transported to the operating site where they are assembled on the foundation. Finally the radiation equipment, computers and the like, are installed after which the building and the equipment is ready to be taken into operation.

In the following detailed description of a preferred embodiment of the invention, a radiation shielded build-

ing adapted for use in radiation surgery of human beings is described. However, it is to be understood that the building according to the invention is applicable for any kind of radiation equipment, e.g. equipment for treatment
5 of animals or foods or any other type of living organism or nonliving material.

Brief description of the drawings

The invention will now be explained by way of example with reference to the accompanying drawings, in
10 which:

- Fig 1 is a perspective view of a building adapted for radiation treatment, including building units according to the invention,
15 Fig 2 is a cross sectional plan view from above of the building in fig 1, and
Fig 3 is a cross sectional side view along the line III-III in fig 2.

Detailed description of a preferred embodiment of the invention

In the drawings is shown a preferred embodiment of a building, according to the invention, adapted especially for radiation surgery treatment of human beings. The
25 building is assembled of three separate building units 1, 1', 2, of which only the outer contour of the building unit 1' is shown in fig 1. A treatment room 3 is jointly formed by the building units 1, 1' and an operator room 4 is formed by the building unit 2.

30 The building units 1, 1', 2 has each, in the preferred embodiment, a length in the order of about 6-9 m, a width of about 3-4 m and a height of about 4-5 m. Dimensions that makes them well suited for transportation on roads or railways as well as by sea.

35 As evident by the drawings, the building units 1, 1' are essentially identical but reversed and include wall portions on three of their four sides, a floor and a roof

portion. The fourth side of each of the building units is open in order to mutually define a comparatively large treatment room 3 when placed adjacent each other. A radiation generating unit 5 for radiation surgery is placed in the treatment room 3 as shown in fig 2 and 3. Accordingly, the treatment room 3 has to be provided with a radiation shielding to prevent radiation from escaping from the treatment room to the environment and to the operator room 4.

The radiation shielding for three of the wall portions 6, which are faced toward the outside, and for the roof portion 7 of the treatment room, is accomplished by each having a double walled structure with an inner partition element 8, an outer partition element 9 and a space 10 forming a closed tank between the inner and outer partition elements 8,9. The partition elements are formed of steel plates or sheets on a system of steel beams, with a space of about 800 to 1400 mm between the plates. The tank 10 may be unitary and common for a whole building unit 1, 1', but it may also be subdivided into smaller tanks. However, the tanks are separate for each of the building units 1, 1'. Each tank forms a closed, liquid tight container for water which is fillable through not shown inlet openings.

The radiation shielding in the intermediate wall 11 between the treatment room 3 and the operator room 4, on the other hand, is provided by a sandwich wall structure including steel plates on a system of steel beams. Between the treatment room 3 and the operator room 4 is also a door 12 which is made of lead to give sufficient radiation shielding.

The floor portion 13 of the building unit 1, 1' is in form of a steel plate and does not in itself have sufficient radiation shielding capacity. However, the floor portion 13 is adapted to interact with a not shown foundation to provide the required radiation shielding.

The wall and roof portions 6, 7 of the building units include inner and outer insulation layers as well as inner and outer covering layers. The building unit 2 also include a recess or accommodation 16 adapted for installation of e.g. ventilation and temperature controlling equipment.

CLAIMS

1. A mobile building unit, including at least two walls (6), a roof (7) and a floor (12), which is
5 movable to an operating site and assembled there to form a building including at least one room (3) defined by at least four walls, a roof, and a floor,
c h a r a c t e r i s e d in that at least two of the walls (6) and the roof (7) comprises a double walled
10 structure including an inner (8) and an outer (9) partition element, forming a closed space (10) therebetween, to allow filling of the spaces with a fillable material once the building is assembled at the operating site, wherein the partition elements and the
15 fillable material in the closed spaces serve as a radiation shielding to allow use of the building as a radiation shielded building for accommodating radiating equipment for treatment, therapy or diagnosing by means of ionising radiation, and to enable easy emptying of the
20 fillable material before possible relocation of the building to another operating site.

2. A building unit according to claim 1, wherein the space (10) forms a closed, liquid impermeable tank.
25

3. A building unit according to claim 2, wherein the fillable material is water which is containable in the tank.

30 4. A building unit according to claim 3, wherein it comprises a system for monitoring the water level.

5. A building unit according to claim 1, wherein the fillable material is sand which is containable in the
35 space (10).

6. A building unit according to any of the preceding claims, wherein it is adapted to be assembled with at least one other building unit (1, 1', 2).

5 7. A building including at least one room (3), enclosed by walls (6), a roof (7) and a floor (12), for accommodating radiating equipment (5) for treatment, therapy or diagnosing by means of ionizing radiation, the walls, the roof and the floor of said building (1, 1')
10 serving as a radiation shielding barrier for preventing radiation at health-impairing levels from escaping to the outside of the building structure, wherein at least two of the walls and the roof comprises a double walled structure comprising an inner (8) and an outer (9) partition element with a space (10) defined therebetween, and
15 a filling inlet through which the space is fillable with a fillable material to allow filling of the space with the fillable material once the building is located at an operating site, where it is to be used, to provide a radiation
20 shielding barrier with a sufficient shielding capacity.

8. A building according to claim 7, wherein the space (10) forms a closed, liquid impermeable tank.

25

9. A building according to claim 8, wherein there are two or more separate tanks (10) in the building.

10. A building according to claim 8, wherein the
30 tank (10) contains water.

11. A building according to claim 8, wherein it comprises a system for monitoring the water level.

35 12. A building according to claim 8, wherein it comprises a system for temperature control of the water.

13. A building according to claim 7, wherein the spaces (10) contains sand.

14. A building according to claim 7, wherein it is adapted for treatment of humans.

15. A building according to claim 7, wherein it is assembled of two or more building units (1, 1').

16. A building according to any of the claims 7-15, wherein at least three of the walls and the roof comprises a double walled structure.

17. A method for constructing a building of the type including at least one room (3), enclosed by walls (6), a roof (7) and a floor (12), adapted for accommodating radiating equipment (5) for treatment, therapy or diagnosing by means of ionising radiation, including to construct the walls, the roof and the floor of said room as a radiation shielding barrier for preventing radiation at health-impairing levels from escaping to the outside of the building during operation of the radiating equipment, characterised by the steps;

to construct the building in a modular form as a mobile unit (1, 1') including at least two walls (6), a roof (7) and a floor (12);

to construct at least two of the walls and the roof of the building unit as a double walled structure comprising an inner (8) and an outer (9) partition element forming a closed space (10) therebetween;

to transport the mobile unit to an operating site and assemble it there; and

to fill the spaces with a fillable material to provide a radiation shielding barrier with a sufficient shielding capacity.

18. A method according to claim 17, including the further step to fill the spaces (10) with water.

19. A method according to claim 17, including the
5 further step to fill the spaces (10) with sand.

20. A method according to claim 17, including the further step to use the building for treatment of humans.

10 21. A method according to any of the claims 17-20, including the further step to assemble the building of at least two building units (1, 1').

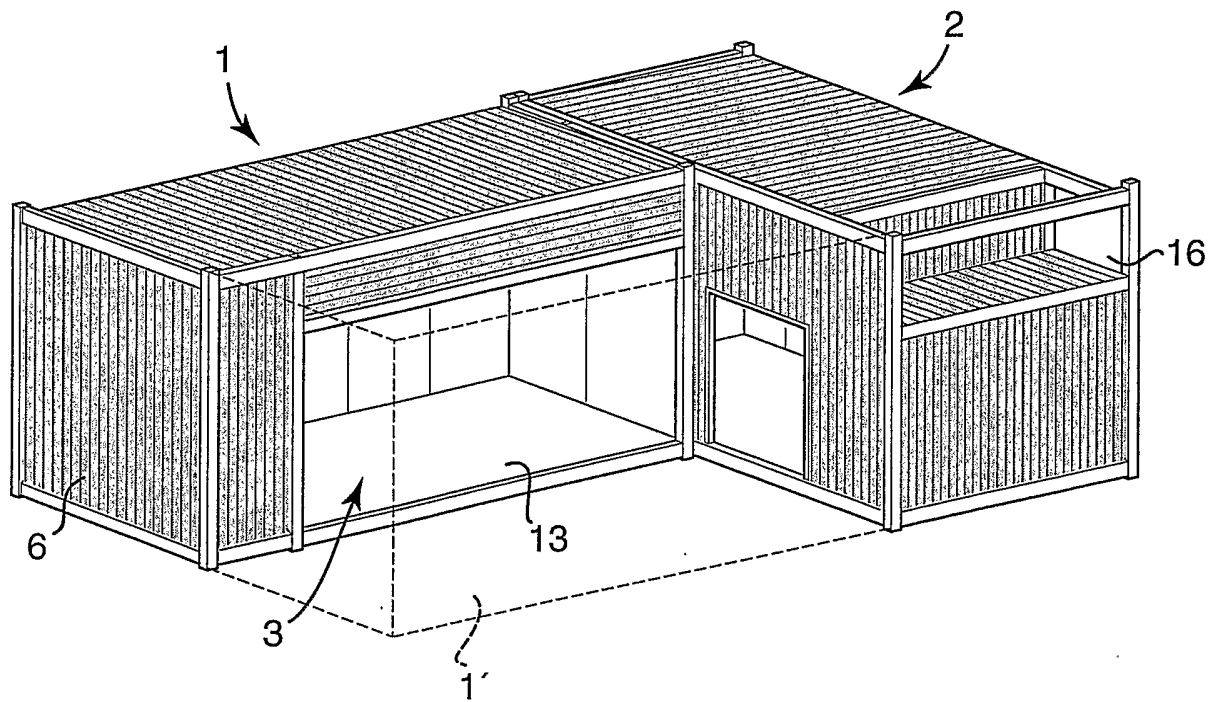
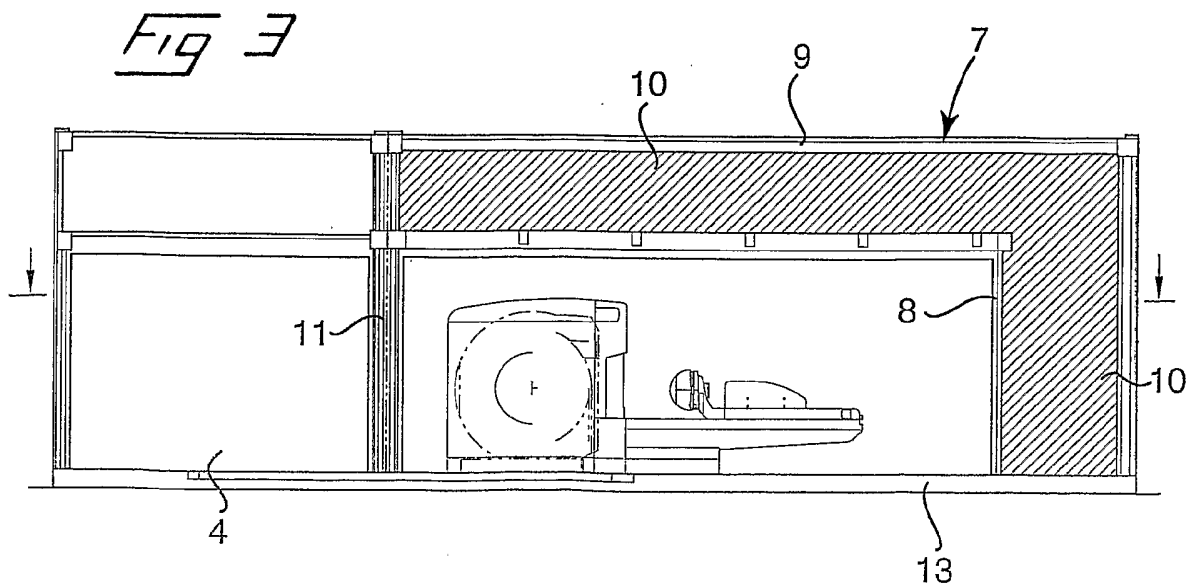
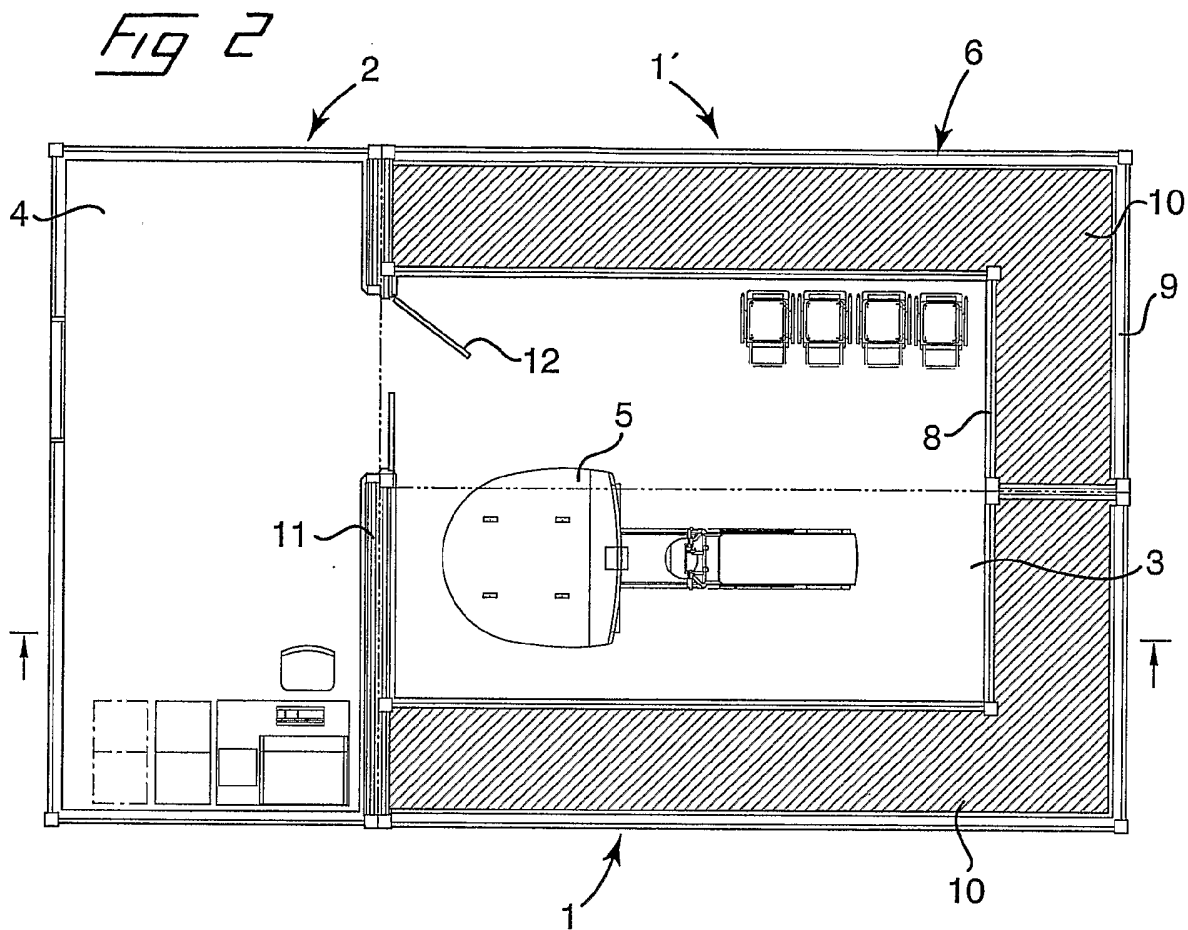

Fig 1



INTERNATIONAL SEARCH REPORT

International application No.

PCT/SE 03/01025

A. CLASSIFICATION OF SUBJECT MATTER

IPC7: G21F 7/00, G21F 3/00

According to International Patent Classification (IPC) or to both national classification and IPC

B. FIELDS SEARCHED

Minimum documentation searched (classification system followed by classification symbols)

IPC7: G21F

Documentation searched other than minimum documentation to the extent that such documents are included in the fields searched

SE,DK,FI,NO classes as above

Electronic data base consulted during the international search (name of data base and, where practicable, search terms used)

C. DOCUMENTS CONSIDERED TO BE RELEVANT

Category*	Citation of document, with indication, where appropriate, of the relevant passages	Relevant to claim No.
X	PATENT ABSTRACTS OF JAPAN (TSUKKAMOTO KENKICHI ET AL) JP 1021400 A 19890124 DW 198909	1-11, 13-21
Y	--	12
Y	PATENT ABSTRACTS OF JAPAN JP 62263500 A 19871116 DW19871	12
A	US 3680498 A (CHARLES J.ROOS), 1 August 1972 (01.08.72)	1-21
	--	

 Further documents are listed in the continuation of Box C.
 See patent family annex.

* Special categories of cited documents	"T" later document published after the international filing date or priority date and not in conflict with the application but cited to understand the principle or theory underlying the invention
"A" document defining the general state of the art which is not considered to be of particular relevance	"X" document of particular relevance: the claimed invention cannot be considered novel or cannot be considered to involve an inventive step when the document is taken alone
"E" earlier application or patent but published on or after the international filing date	"Y" document of particular relevance: the claimed invention cannot be considered to involve an inventive step when the document is combined with one or more other such documents, such combination being obvious to a person skilled in the art
"L" document which may throw doubts on priority claim(s) or which is cited to establish the publication date of another citation or other special reason (as specified)	"&" document member of the same patent family
"O" document referring to an oral disclosure, use, exhibition or other means	
"P" document published prior to the international filing date but later than the priority date claimed	

Date of the actual completion of the international search

22 Sept 2003

Date of mailing of the international search report

26 509-2003

 Name and mailing address of the ISA/
 Swedish Patent Office
 Box 5055, S-102 42 STOCKHOLM
 Facsimile No. +46 8 666 02 86

Authorized officer

 Karin Jansdotter / itw
 Telephone No. +46 8 782 25 00

INTERNATIONAL SEARCH REPORT

International application No.

PCT/SE 03/01025

C (Continuation). DOCUMENTS CONSIDERED TO BE RELEVANT		
Category*	Citation of document, with indication, where appropriate, of the relevant passages	Relevant to claim No.
A	DE 3629335 A1 (TRÄBING,ERNST), 3 March 1988 (03.03.88) --	1-21
A	EP 0257016 A2 (STÖGER,HERMAN), 24 February 1988 (24.02.88) --	1-21
A	PATENT ABSTRACTS OF JAPAN JP 62206497 A 19870910 DW 198742 -- -----	1-21

INTERNATIONAL SEARCH REPORT

International application No.

PCT/SE 03/01025

Patent document cited in search report			Publication date	Patent family member(s)		Publication date
US	3680498	A	01/08/72	NONE		
DE	3629335	A1	03/03/88	NONE		
EP	0257016	A2	24/02/88	AT	200286 A	15/10/87
				AT	385810 B	25/05/88