



US00D881846S

(12) **United States Design Patent**  
**Chen**

(10) **Patent No.:** **US D881,846 S**

(45) **Date of Patent:** **\*\* Apr. 21, 2020**

(54) **VIBRATION DIAPHRAGM FOR LOUDSPEAKER**  
  
(71) Applicant: **TYMPHANY ACOUSTIC TECHNOLOGY (HUIZHOU) CO., LTD.**, Huizhou, Guangdong Province (CN)  
  
(72) Inventor: **Zhi Chen**, Huizhou (CN)  
  
(73) Assignee: **TYMPHANY ACOUSTIC TECHNOLOGY (HUIZHOU) CO., LTD.**, Huizhou, Guangdong Province (CN)

1,552,311 A \* 9/1925 Kellogg ..... H04R 7/00  
181/169  
1,736,042 A \* 11/1929 Kent ..... H04R 7/12  
181/156  
1,828,513 A \* 10/1931 Smythe ..... H04R 7/14  
181/163  
1,829,355 A \* 10/1931 Houghton ..... H04R 7/20  
181/173  
1,891,566 A \* 12/1932 McKellip ..... H04R 7/20  
181/172  
1,913,645 A \* 6/1933 Stenger ..... H04R 7/12  
181/161  
1,995,080 A \* 3/1935 Shotwell ..... H04R 9/06  
381/398  
2,302,178 A \* 11/1942 Brennan ..... H04R 7/20  
181/169

(\*\*) Term: **15 Years**  
  
(21) Appl. No.: **29/650,412**  
  
(22) Filed: **Jun. 6, 2018**

(Continued)

*Primary Examiner* — Paula Allen Greene  
(74) *Attorney, Agent, or Firm* — Muncy, Geissler, Olds & Lowe, P.C.

(30) **Foreign Application Priority Data**

Dec. 6, 2017 (CN) ..... 2017 3 0615452

(51) **LOC (12) Cl.** ..... **14-01**  
(52) **U.S. Cl.** ..... **D14/222**  
USPC

(57) **CLAIM**

The ornamental design for vibration diaphragm for loudspeaker, as shown and described.

(58) **Field of Classification Search**  
USPC ..... D14/222, 216, 215, 221, 204;  
181/144-148, 156, 170, 173, 141, 182,  
181/396, 186; 381/380, 381, 421, 423,  
381/426, 427, 397, 186, 182, 412, 386,  
381/409; 455/90.3, 575.1, 569.1  
CPC ... H04R 1/02; H04R 1/00; H04R 9/06; H04R  
25/00; H04R 7/12; H04R 11/02; H04R  
7/04; H04R 9/04; H05K 5/00  
See application file for complete search history.

**DESCRIPTION**

FIG. 1 is a perspective view of a vibration diaphragm for loudspeaker, showing the new design;  
FIG. 2 is a front view thereof;  
FIG. 3 is a rear view thereof;  
FIG. 4 is a left side view thereof;  
FIG. 5 is a right side view thereof;  
FIG. 6 is a top view thereof;  
FIG. 7 is a bottom view thereof;  
FIG. 8 is a sectional view taken along line A-A of FIG. 6; and,  
FIG. 9 is a partial enlarged view of area B of FIG. 8.

(56) **References Cited**

**U.S. PATENT DOCUMENTS**

834,629 A \* 10/1906 Mobley ..... 181/164  
1,194,056 A \* 8/1916 Morse ..... H04R 7/00  
181/170

**1 Claim, 6 Drawing Sheets**

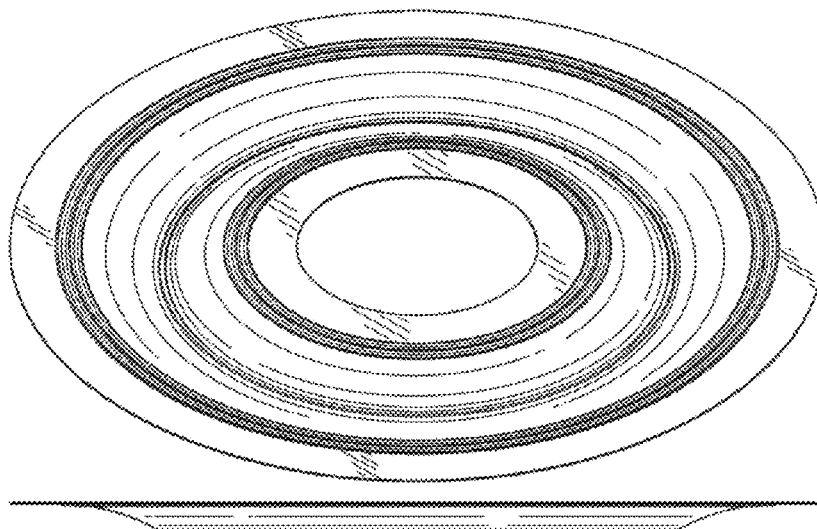

# US D881,846 S

(56)

## References Cited

### U.S. PATENT DOCUMENTS

2,512,323	A *	6/1950	Gersch .....	H04R 7/12	4,815,558	A *	3/1989	Krainhofer .....	H04R 1/025
				181/157					181/141
2,551,447	A *	5/1951	Marquis .....	H04R 9/025	5,425,107	A *	6/1995	Bertagni .....	H04R 7/04
				381/412					381/426
2,638,509	A *	5/1953	Charlesworth .....	H04R 31/003	D360,886	S *	8/1995	Hall .....	D14/216
				181/171	5,455,396	A *	10/1995	Willard .....	H04R 7/20
2,924,290	A *	2/1960	Zuerker .....	H04R 7/12					181/172
				181/165	5,625,701	A *	4/1997	Scanlan .....	H04R 7/16
2,984,712	A *	5/1961	Fabel .....	H04R 9/025					381/403
				181/171	D480,709	S *	10/2003	Proni .....	D14/216
2,998,496	A *	8/1961	Hassan .....	H04R 9/04	D504,416	S *	4/2005	Dayan .....	D14/216
				381/398	6,929,092	B2 *	8/2005	Abe .....	H04R 7/122
3,046,362	A *	7/1962	White .....	H04R 7/12					181/167
				181/164	6,944,310	B2 *	9/2005	Ito .....	H04R 9/06
3,111,187	A *	11/1963	Barlow .....	H04R 7/06					181/171
				181/168	D523,848	S *	6/2006	Shing .....	D14/221
3,152,661	A *	10/1964	Wolff .....	H04R 7/06	D615,964	S *	5/2010	Chen .....	D14/216
				181/168	D619,994	S *	7/2010	Chen .....	D14/216
3,354,541	A *	11/1967	Gosma .....	H04R 9/02	D638,402	S *	5/2011	Hoehn .....	D14/215
				29/594	D650,770	S *	12/2011	Chen .....	D14/216
3,508,626	A *	4/1970	Robbins .....	H04R 7/02	D650,771	S *	12/2011	Chen .....	D14/216
				181/168	D651,588	S *	1/2012	Chen .....	D14/216
D239,538	S *	4/1976	Wagner .....	D14/216	8,422,724	B2 *	4/2013	Corynen .....	H04R 7/14
D248,647	S *	7/1978	Nussdorfer .....	D14/216					381/398
D250,586	S *	12/1978	Nussdorfer .....	D14/216	D689,470	S *	9/2013	Chen .....	D14/215
4,293,741	A *	10/1981	Digre .....	H04R 9/025	9,113,250	B2 *	8/2015	Huang .....	H04R 7/02
				335/231	D738,861	S *	9/2015	Yang .....	D14/222
D267,644	S *	1/1983	Warner .....	D14/222	D804,453	S *	12/2017	Katsuno .....	D14/222
D286,771	S *	11/1986	Willy .....	D14/222	2002/0025059	A1 *	2/2002	Kudo .....	H04R 7/125
									381/423
					2006/0088184	A1 *	4/2006	Ohashi .....	H04R 7/16
									381/430

\* cited by examiner

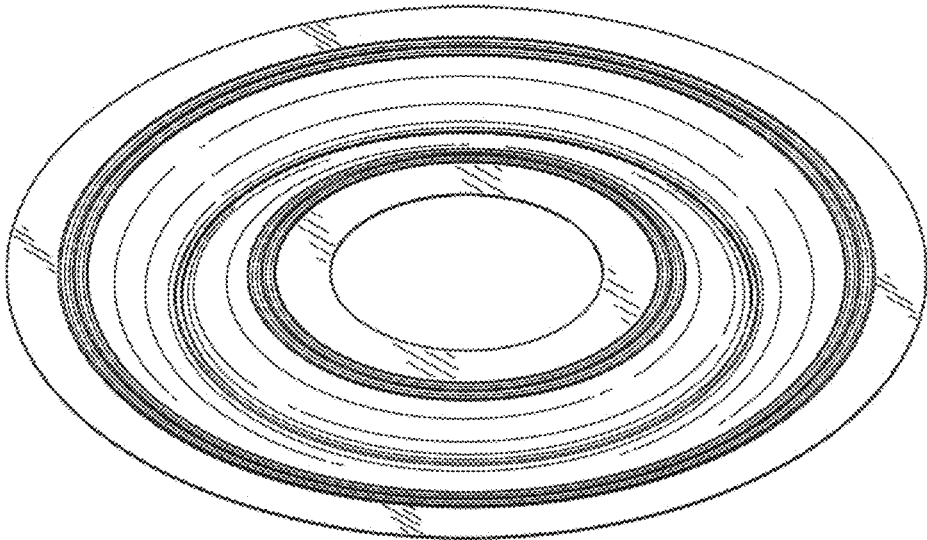

Fig. 1



Fig. 2

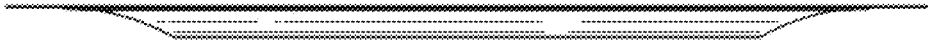

Fig. 3



Fig. 4

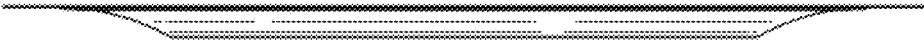

Fig. 5

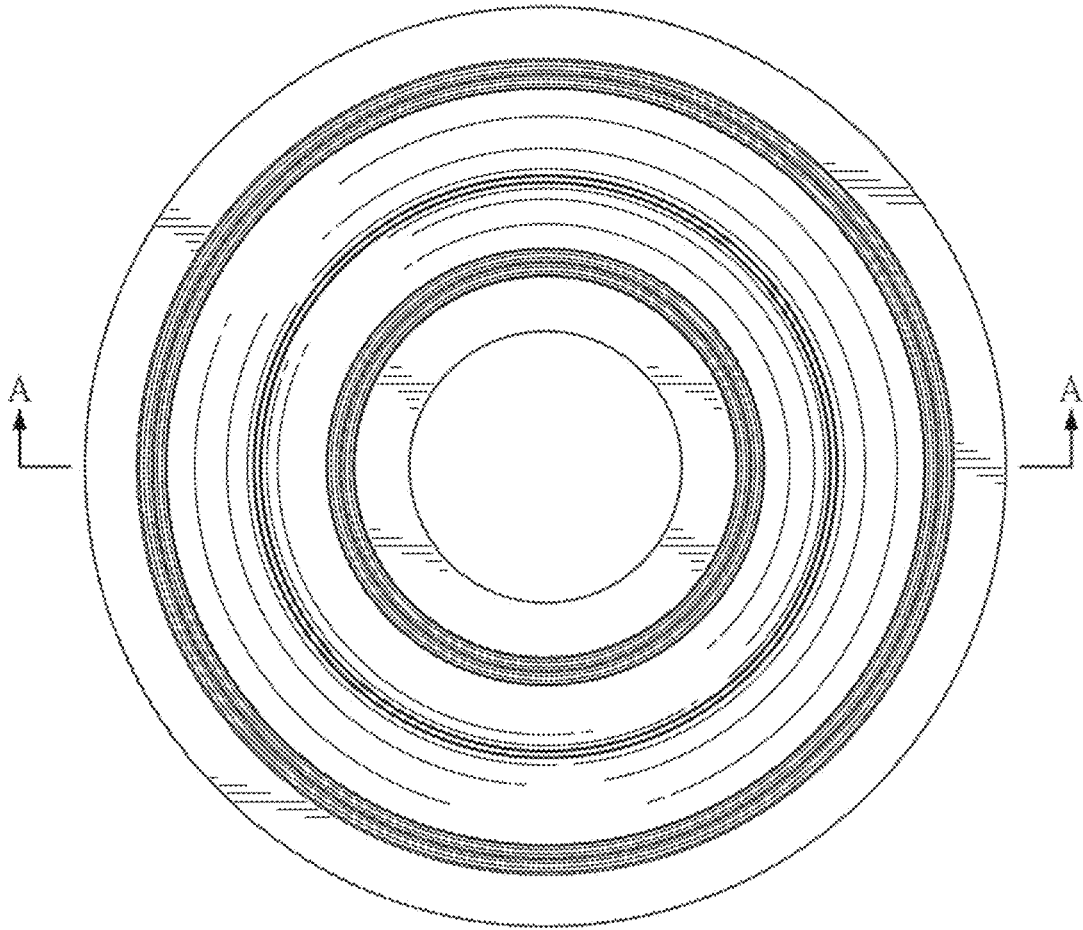

Fig. 6

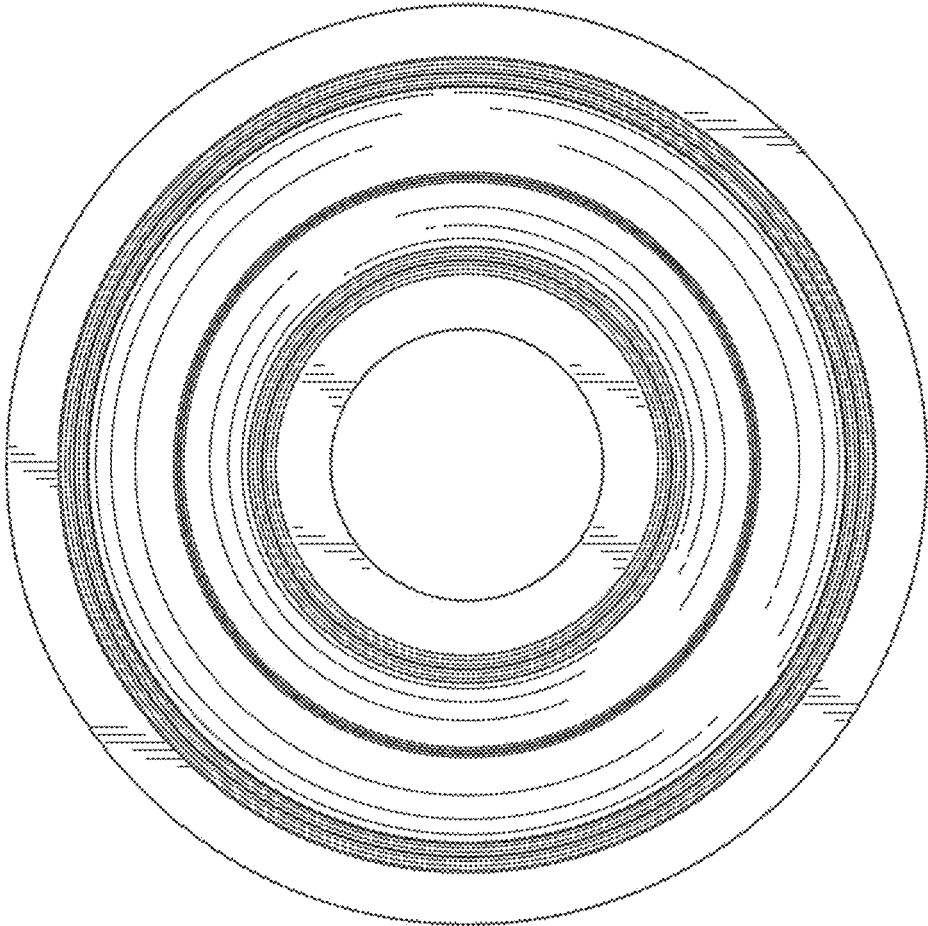

Fig. 7



Fig. 8

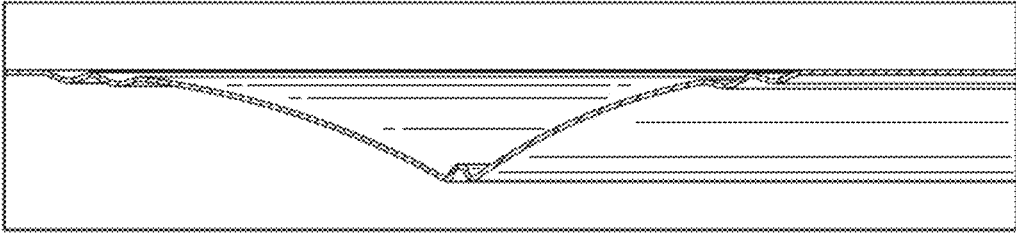

Fig. 9