

(12) **UK Patent Application** (19) **GB** (11) **2 307 350** (13) **A**

(43) Date of A Publication **21.05.1997**

(21) Application No **9623666.6**

(22) Date of Filing **12.11.1996**

(30) Priority Data

(31) **95040949** (32) **13.11.1995** (33) **KR**

(71) Applicant(s)

**Daewoo Electronics Co., Ltd**

**(Incorporated in the Republic of Korea)**

**541 5-Ga Namdaemoon-Ro, Jung-Gu, Seoul 100-095,  
Republic of Korea**

(72) Inventor(s)

**Yong-Hwan Choi**

(74) Agent and/or Address for Service

**Page White & Farrer**

**54 Doughty Street, LONDON, WC1N 2LS,  
United Kingdom**

(51) INT CL<sup>6</sup>  
**H01Q 3/18**

(52) UK CL (Edition O )  
**H1Q QFS**

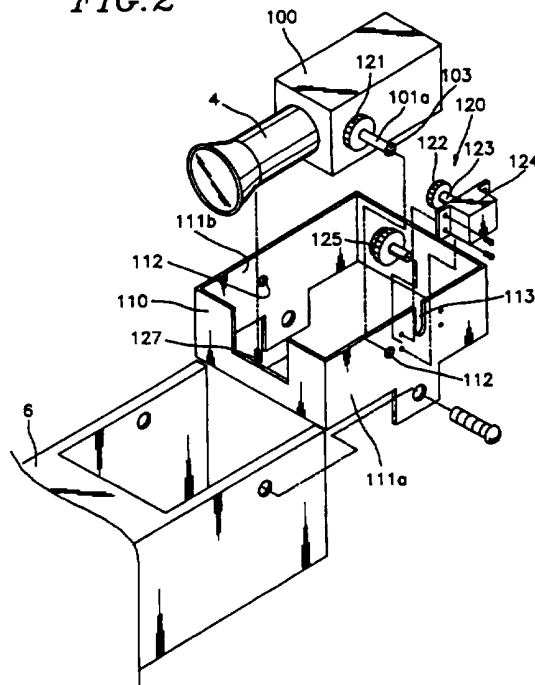
(56) Documents Cited  
**GB 2250135 A**

(58) Field of Search  
UK CL (Edition O ) **H1Q QFS QFU QKH QKN**  
INT CL<sup>6</sup> **H01Q 3/18**  
**ONLINE:WPI**

(54) **Adjusting the elevation angle of a feed horn of a parabolic antenna**

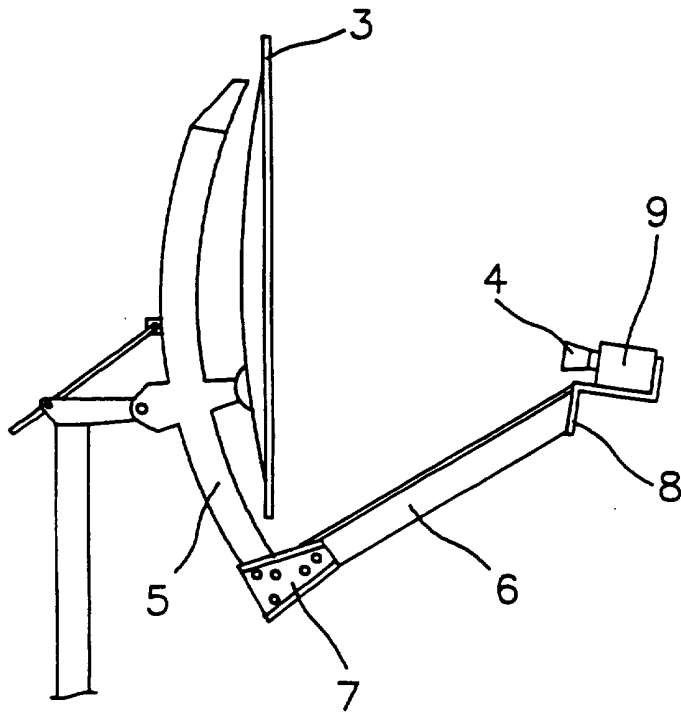
(57) In a parabolic antenna provided with a reflector and an arm 6 which carries a casing 100 enclosing a low noise blockdown converter (LNB), with a feed horn 4 protruding from a front side of the casing, the latter is attached to the arm via a housing 110 which allows adjustment of the elevation angle of the feed horn. As shown the LNB casing has a pair of hinge pins 101 fitted in apertures 112 in side members 111 of the housing. One hinge pin carries a gear 121 which can be driven by a motor 124 attached to the housing, allowing the elevation angle of the casing to be adjusted.

*FIG. 2*



**GB 2 307 350 A**

**FIG. 1**  
(PRIOR ART)



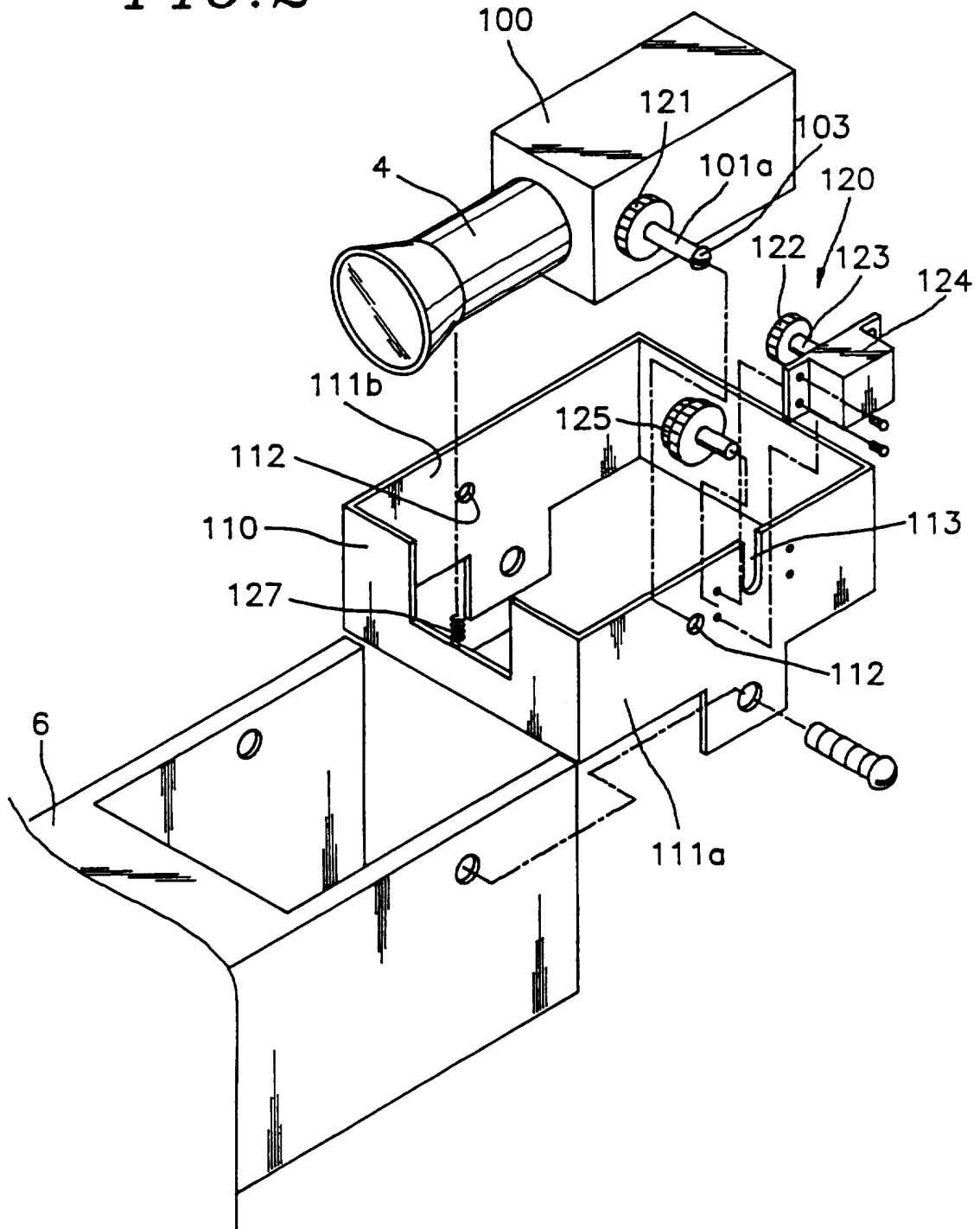
*FIG. 2*

FIG. 3

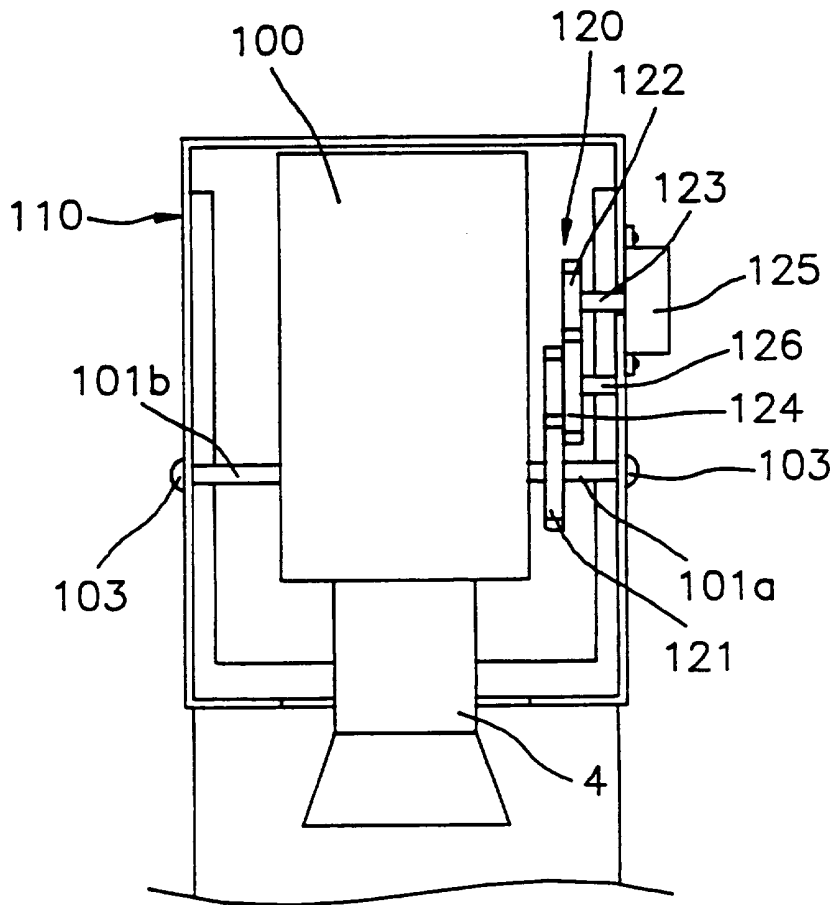
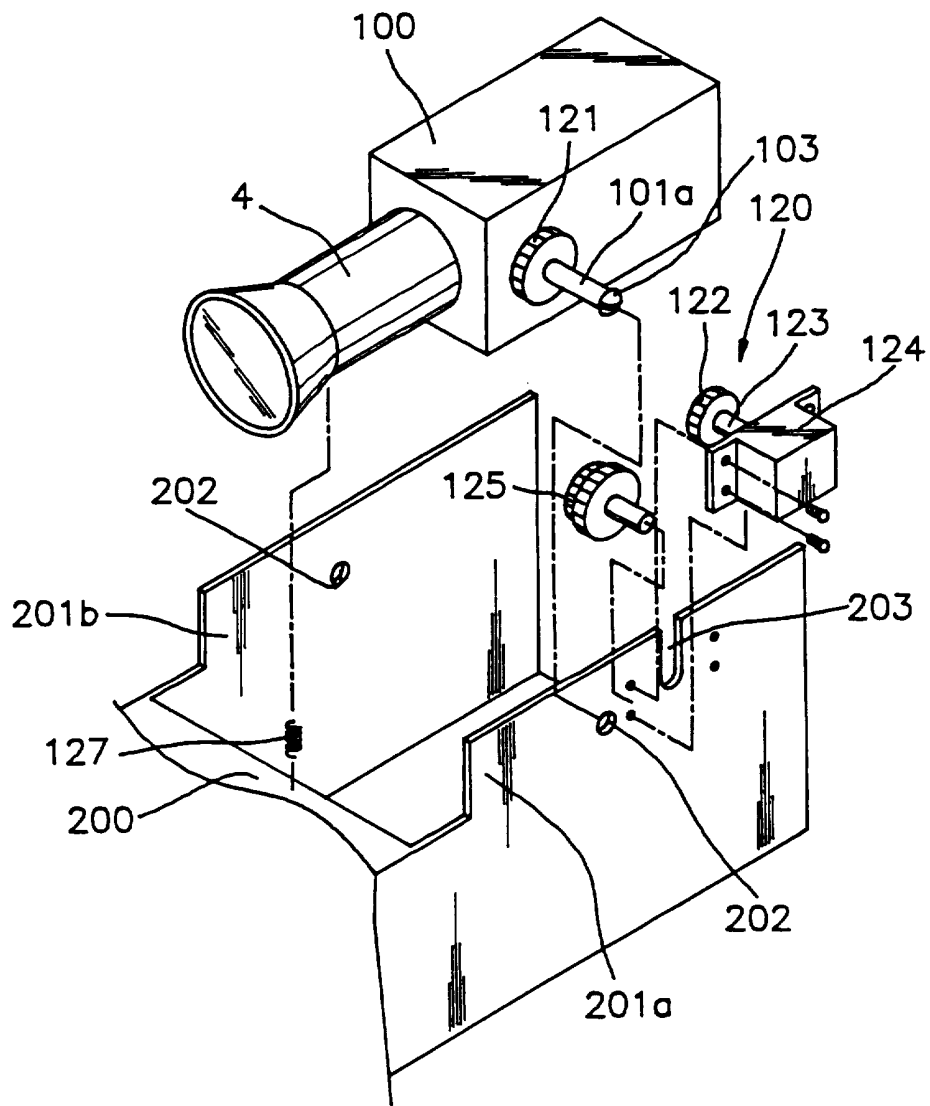
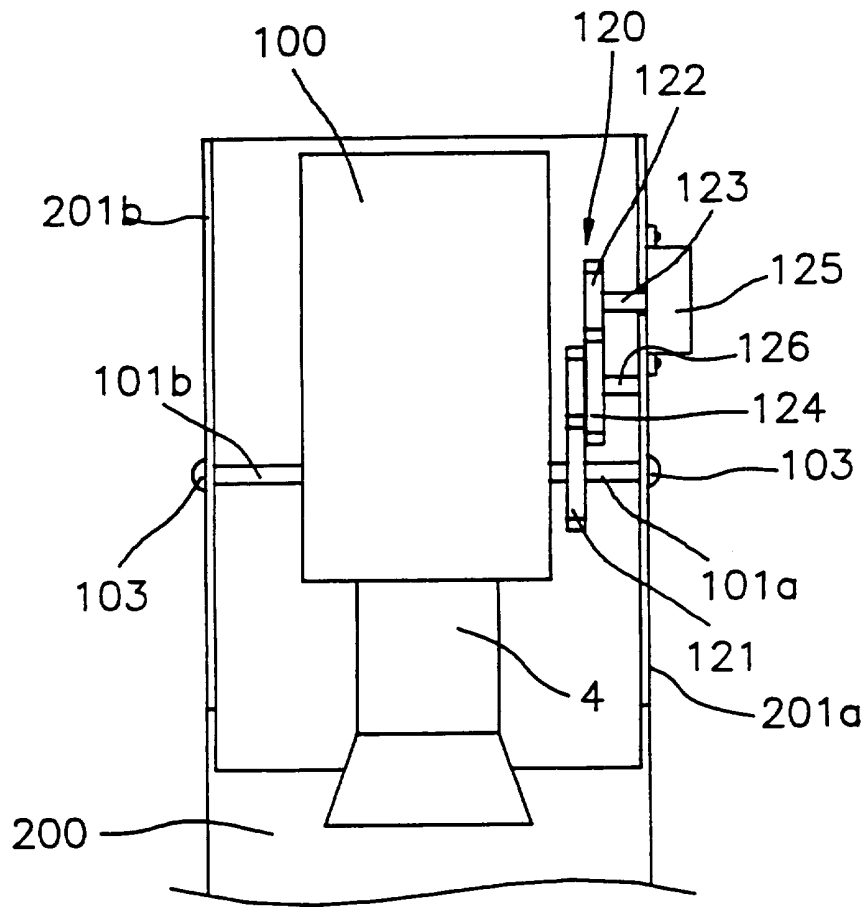


FIG. 4



*FIG. 5*

1  
PARABOLIC ANTENNA CAPABLE OF ADJUSTING  
THE ELEVATION ANGLE OF A FEED HORN.

5

The present invention relates to a parabolic antenna; and, more particularly, to a parabolic antenna which allows the elevation angle of a feed horn incorporated therein to be adjusted with ease.

10

There is shown in Fig. 1 a schematic view of a conventional parabolic antenna disclosed in U.S. Patent No. 4,819,007. The conventional parabolic antenna includes a paraboloidal reflector 3, a case 9 enclosing a low noise blockdown converter ("LNB"), a feed horn 4 protruding from the front side of the LNB case 9, a frame 5 and an arm 6.

The frame 5 is fixed on the rear side of the reflector 3 at one end by using bolts. The arm 6 is connected to the other end of the frame 5 at one end through a pair of gussets 7 bolted to the frame 5 and the arm 6. The LNB case 9 with the feed horn 4 is fixed to the other free end of the arm 6 through a support plate 8. In this way, the feed horn 4 comes to be positioned at a focal point of the reflector 3.

However, in such a conventional parabolic antenna, since the LNB case is fixed to the free end of the arm, making it

difficult to adjust the elevation angle of the feed horn therein, a precise positioning of the feed horn at the focal point of the reflector becomes difficult.

5

It is, therefore, a primary object of the invention to provide a parabolic antenna which allows the elevation angle of a feed horn to be adjusted with ease, thereby facilitating a precise positioning of the feed horn at the focal point of a reflector.

In accordance with an aspect of the present invention, there is provided a parabolic antenna provided with a reflector and an arm, which comprises: a housing fixed to a free end of the arm; a case enclosing an LNB, the LNB case being rotatably supported by the housing; a feed horn protruding from a front side of the LNB case; and a means for adjusting an elevation angle of the feed horn.

In accordance with another aspect of the present invention, there is provided a parabolic antenna provided with a reflector and an arm, which comprises: a case enclosing an LNB, the LNB case being rotatably supported to a free end of the arm; a feed horn protruding from a front side of the LNB case; and means for adjusting an elevation angle of the feed horn.



The above and other objects and features of the instant invention will become apparent from the following description of preferred embodiments taken in conjunction with the accompanying drawings, in which:

Fig. 1 represents a schematic view of a conventional parabolic antenna;

Fig. 2 depicts an exploded perspective view of a parabolic antenna in accordance with a preferred embodiment of the present invention, mainly showing the housing and the means for adjusting the elevation angle of the feed horn;

Fig. 3 sets forth a front view of the parabolic antenna in Fig. 2;

Fig. 4 presents an exploded perspective view of a parabolic antenna in accordance with another preferred embodiment of the present invention, mainly showing the housing and the means for adjusting the elevation angle of the feed horn; and

Fig. 5 sets forth a front view of the parabolic antenna in Fig. 4.

Although the main aspect of a parabolic antenna in accordance with the present invention is shown in Figs. 2 to

5, Fig. 1 will also be referenced in describing the inventive parabolic antenna. Furthermore, like reference numerals in the drawings represent same components.

Referring to Figs. 1 to 3, a parabolic antenna in accordance with a preferred embodiment of the present invention includes a paraboloidal reflector 3, a case 100 enclosing a low noise blockdown converter ("LNB"), the LNB case 100 having a pair of hinge pins 101 coaxially outwardly protruding from both sides thereof, a feed horn 4 protruding from a front side of the LNB case 100 and positioned at a focal point of the reflector 3, an arm 6, a housing 110 for rotatably supporting the LNB case 100 and a means 120 for adjusting the elevation angle of the feed horn 4.

The frame 5 is fixed on the rear side of the reflector 3 at one end by using bolts. The arm 6 is connected to the other end of the frame 5 at one end through a pair of gussets 7 bolted to the frame 5 and the arm 6.

As shown in detail in Figs. 2 and 3, the housing 110 is fixed to the free end of the arm 6, having a pair of supporting members 111a, 111b spaced apart from each other to receive the LNB case 100 therebetween. The supporting members 111a, 111b are provided with a pair of apertures 112 into which the hinge pins 101a, 101b of the LNB case 100 are snugly fitted, respectively, thereby rotatably supporting the LNB case 100. The elevation angle adjusting means 120 includes a driven gear 121 engaged on the hinge pin 101a, a driving gear

122 engaged on an input shaft 123 rotated by an appropriate means, e.g., motor 124 and a reduction gear 125 rotatably coupled on a supporting shaft 126. The motor 124 is attached to the supporting member 111a in such a way that the input shaft 123 rotatably passes through the supporting member 111a. The supporting shaft 126 is fixed to the supporting member 111a in such a way that the reduction gear 125 is disposed between and meshed with the driving and the driven gears 122, 121. The driving and the driven gears 122, 121 may directly be meshed with each other without the reduction gear 125. The input shaft 123 is selectively rotated depending on the activation of the motor 124 and the gears 122, 125 and 121 are, in turn, rotated, thereby rotating the LNB case 100. Therefore, if desired, the elevation angle of the feed horn 4 can be adjusted by rotating the input shaft 123.

The supporting member 111a is further provided with an open slot 113 extending vertically, to thereby facilitate the attachment of the motor 124 and the input shaft 123 to the supporting member 111a by the input shaft 123 moving down along the open slot 113. Each of the hinge pins 101a, 101b is provided with an elastic hook 103 at its end, thereby preventing the LNB case 100 from moving from side to side. Furthermore, in order to prevent an up and down movement of the feed horn 4 due to the backlash between the gears, a tensile spring 127 is disposed such that both ends thereof are connected to the housing 110 and the feed horn 4, thereby

biasing the feed horn 4 downwardly.

There is shown in Figs. 4 and 5 another preferred embodiment of the present invention. The second preferred embodiment is similar to the first except that the LNB case 100 is directly fixed to the free end of an arm 200 without the housing 110.

In the parabolic antenna of the second preferred embodiment, the arm 200 has a pair of protruding portions 201a, 201b spaced apart from each other to receive the LNB case 100 therebetween. The protruding portions 201a, 201b are provided with a pair of holes 202 into which the hinge pins 101a, 101b of the LNB case 100 are snugly fitted, respectively, thereby rotatably supporting the LNB case 100. The protruding portion 201a is further provided with an open slot 203. The motor 124 is attached to the protruding portion 201a in such a way that the input shaft 123 rotatably passes therethrough. The supporting shaft 126 is fixed to the protruding portion 201a in such a way that the reduction gear 125 is disposed between and meshed with the driving and the driven gears 122, 121. The protruding portion 201a is further provided with an open slot 203 extending vertically to thereby facilitate the attachment of the motor 124 and the input shaft 123 thereto by the input shaft 123 moving down along the open slot 203. The tensile spring 127 is disposed such that both ends thereof are connected to the arm 200 and the feed horn 4, thereby biasing the feed horn 4 downwardly.

According to the present invention, the elevation angle of the feed horn can be adjusted with ease, thereby facilitating the precise positioning of the feed horn at the focal point of the reflector.

5           Although the invention has been shown and described with respect to the preferred embodiments, it will be understood by those skilled in the art that various changes and modifications may be made without departing from the scope of the invention as defined in the following claims.

What is claimed is:

1. A parabolic antenna provided with a reflector and an arm,  
which comprises:

- 5           a housing fixed to a free end of the arm;  
          a case enclosing a low noise blockdown converter ("LNB"),  
the LNB case being rotatably supported by the housing;  
          a feed horn protruding from a front side of the LNB case;  
and  
10           a means for adjusting an elevation angle of the feed  
horn.

2. The parabolic antenna of claim 1, wherein the LNB case  
has a pair of hinge pins; the housing has a pair of supporting  
15       members for rotatably supporting the LNB case, the supporting  
members being spaced from each other and provided with a pair  
of apertures into which the hinge pins of the LNB case are  
snugly fitted, respectively; and the elevation angle adjusting  
means includes a driven gear engaged on one of the hinge pins  
20       of the LNB case and a driving gear engaged on an input shaft,  
the input shaft rotatably passing through one of the  
supporting members, the driving gear and the driven gear being  
meshed with each other and, in turn, rotated by rotating the  
input shaft.

25

3. The parabolic antenna of claim 2, wherein the elevation

angle adjusting means further includes a reduction gear disposed between and meshed with the driving and the driven gears.

5 4. The parabolic antenna of claim 2, wherein each of the hinge pins is provided with an elastic hook at its end for preventing the LNB case from moving from side to side.

10 5. The parabolic antenna of claim 2, wherein the elevation angle adjusting means further includes a tensile spring both ends of which are connected to the housing and the feed horn, respectively, thereby biasing the feed horn downwardly.

15 6. A parabolic antenna provided with a reflector and an arm, which comprises:

a case enclosing a low noise blockdown converter ("LNB"), the LNB case being rotatably supported to a free end of the arm;

20 a feed horn protruding from a front side of the LNB case; and

means for adjusting an elevation angle of the feed horn.

25 7. The parabolic antenna of claim 6, wherein the LNB case has a pair of hinge pins; the arm has a pair of protruding portions for rotatably supporting the LNB case, the protruding portions being spaced apart from each other and provided with

a pair of holes in which the hinge pins of the LNB case are snugly fitted, respectively; and the elevation angle adjusting means includes a driven gear engaged on one of the hinge pins and a driving gear engaged on an input shaft, the input shaft rotatably passing through one of the protruding portion of the arm, the driving and the driven gears being meshed with each other and, in turn, rotated by rotating the input shaft.

8. The parabolic antenna of claim 7, wherein the elevation angle adjusting means further includes a reduction gear disposed between and meshed with the driving and the driven gears.

9. The parabolic antenna of claim 7, wherein each of the hinge pins is provided with a hook at its end for preventing the LNB case from moving from side to side.

10. The parabolic antenna of claim 7, wherein the elevation angle adjusting means further includes a tensile spring both ends of which are connected to the arm and the feed horn, respectively, thereby biasing the feed horn downwardly.

11. A parabolic antenna constructed and arranged substantially as herein described with reference to or as shown in Figures 2-5 of the accompanying drawings.





Application No: GB 9623666.6  
Claims searched: 1-11

Examiner: M. G. Clarke  
Date of search: 26 February 1997

**Patents Act 1977**  
**Search Report under Section 17**

**Databases searched:**

UK Patent Office collections, including GB, EP, WO & US patent specifications, in:  
UK Cl (Ed.O): H1Q QFS, QFU, QKH, QKN  
Int Cl (Ed.6): H01Q 3/18  
Other: Online: WPI

**Documents considered to be relevant:**

Category	Identity of document and relevant passage	Relevant to claims
X	GB2250135A Sheraton Investments Ltd - whole document	1.6 at least

X	Document indicating lack of novelty or inventive step	A	Document indicating technological background and/or state of the art.
Y	Document indicating lack of inventive step if combined with one or more other documents of same category.	P	Document published on or after the declared priority date but before the filing date of this invention.
&	Member of the same patent family	E	Patent document published on or after, but with priority date earlier than, the filing date of this application.