



US008397454B2

(12) **United States Patent**
Commins et al.

(10) **Patent No.:** **US 8,397,454 B2**
(45) **Date of Patent:** **Mar. 19, 2013**

(54) **BUILDING WALL FOR RESISTING LATERAL FORCES**

(75) Inventors: **Alfred D. Commins**, Friday Harbor, WA (US); **Robert C. Gregg**, Yorba Linda, CA (US); **William F. Leek**, Anaheim, CA (US); **Karen W. Colonias**, Danville, CA (US); **Arthur R. Linn**, Byron, CA (US)

(73) Assignee: **Simpson Strong-Tie Company, Inc.**, Pleasanton, CA (US)

(*) Notice: Subject to any disclaimer, the term of this patent is extended or adjusted under 35 U.S.C. 154(b) by 207 days.

(21) Appl. No.: **08/975,940**

(22) Filed: **Nov. 21, 1997**

(65) **Prior Publication Data**

US 2001/0002529 A1 Jun. 7, 2001

(51) **Int. Cl.**
E02D 27/00 (2006.01)

(52) **U.S. Cl.** **52/293.3**; 52/481.1; 52/790.1; 52/800.18; 52/765

(58) **Field of Classification Search** 52/702, 52/167.1, 167.3, 293.3, 477, 764, 765, 514, 52/790.1, 800.18, 800.12, 479, 481.1, 202, 52/295, 241, 223.14

See application file for complete search history.

(56) **References Cited**

U.S. PATENT DOCUMENTS

140,526 A 7/1873 Munson
328,185 A 10/1885 Butcher
390,732 A 10/1888 Weston
673,558 A 5/1901 Kline
1,353,998 A 9/1920 Laughlin

1,604,605 A 10/1926 Purdy
1,607,166 A 11/1926 McCall
1,622,962 A 3/1927 Michod
1,689,642 A 10/1928 Rappleyea
RE17,154 E 12/1928 Purdy
1,719,200 A * 7/1929 Schumacher 52/800.12 X
1,742,045 A 12/1929 Menes
1,849,273 A 3/1932 Broderick
1,895,667 A 1/1933 Junkers

(Continued)

FOREIGN PATENT DOCUMENTS

AU 228 186 1/1959
AU 549294 1/1983

(Continued)

OTHER PUBLICATIONS

LBN—Light Beam Inc., Steel Homes 1995.

(Continued)

Primary Examiner — Christine T Cajilig

(74) *Attorney, Agent, or Firm* — James R. Cypher; Charles R. Cypher

(57) **ABSTRACT**

This invention relates to an improved wall for resisting lateral forces imposed on a building that incorporates the wall. Specifically, this invention relates to a wall in a light-frame building having within it a sub-component specifically designed to resist lateral forces imposed on the building such as those caused by an earthquake or by wind loading. The wall is formed with a bottom plate that rests on the underlying structural component of the building. A plurality of vertically-disposed studs connect to the bottom plate, and a top plate is supported by and connects to the vertically-disposed studs. A shear-resisting assembly connects to the top plate and the underlying structural component. The shear-resisting assembly has top and bottom struts and first and second chords and a planar shear resisting element connected thereto.

13 Claims, 16 Drawing Sheets

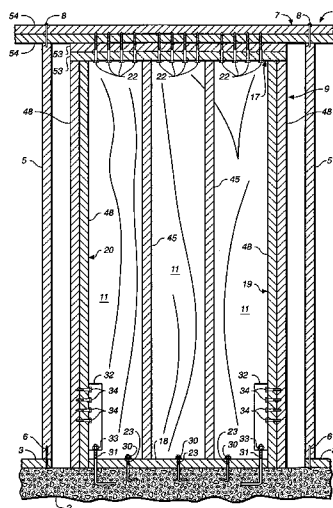
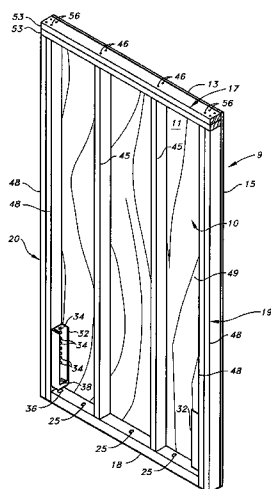

U.S. PATENT DOCUMENTS							
1,997,809	A	4/1935	Cole	4,157,002	A	6/1979	Adolph
2,010,971	A	8/1935	Thomson	4,182,080	A	1/1980	Naylor
2,020,988	A	11/1935	Balletta	4,220,423	A	9/1980	Sivachenko
2,053,226	A	9/1936	Ruge	4,221,087	A	9/1980	Lowe
2,063,010	A	12/1936	Balduf	4,250,671	A	2/1981	Hirsch et al.
2,076,728	A	4/1937	Keller	4,283,892	A	8/1981	Brown
2,080,593	A	5/1937	Albert	4,292,782	A	10/1981	Schaeffer
2,089,023	A	8/1937	Hahn	4,295,299	A	10/1981	Nelson
2,124,519	A	7/1938	Pierson et al.	4,295,318	A	10/1981	Perlman
2,137,767	A	11/1938	Betcone	4,301,628	A	11/1981	Lowe
2,154,520	A	4/1939	Mackin	4,309,853	A	1/1982	Lowe
2,160,225	A	5/1939	Newman	4,321,776	A	3/1982	Delight
2,180,830	A	11/1939	Tourneau	4,339,903	A	7/1982	Menge
2,191,804	A	2/1940	O'Malley	4,366,659	A	1/1983	Jensen
2,191,904	A	2/1940	O'Malley	4,370,843	A	2/1983	Menge
2,193,550	A	3/1940	Coe, Jr.	4,435,932	A	3/1984	Seaburg et al.
2,254,190	A	* 8/1941	Ricken 52/800.18 X	4,439,957	A	4/1984	Raasakka
2,256,394	A	9/1941	Lamel	4,441,286	A	4/1984	Skvaril
2,263,214	A	11/1941	Larkin et al.	4,441,289	A	4/1984	Ikuo et al.
2,271,584	A	2/1942	Fellom	4,471,591	A	9/1984	Jamison
2,278,331	A	3/1942	Meyercord	4,498,264	A	2/1985	McCafferty et al.
2,281,185	A	4/1942	Forster	4,514,950	A	5/1985	Goodson, Jr.
2,445,491	A	7/1948	Moloney	4,522,000	A	6/1985	Barari
2,457,964	A	1/1949	Wyche	4,546,590	A	10/1985	Finch et al.
2,497,887	A	2/1950	Hilpert	4,552,094	A	* 12/1985	Johnson 52/800.12 X
2,576,530	A	11/1951	Medal	4,559,748	A	12/1985	Ressel
2,033,610	A	4/1953	Hervey	4,563,851	A	1/1986	Long
2,666,238	A	1/1954	Hagerdon	4,577,826	A	3/1986	Bergstrom et al.
2,725,608	A	* 12/1955	Parslow 52/213	4,603,531	A	8/1986	Nash
2,742,114	A	4/1956	Behlen	4,631,894	A	12/1986	Jerila
2,743,980	A	5/1956	Hobbs	4,633,634	A	1/1987	Nemmer et al.
2,803,856	A	8/1957	Kofahl et al.	4,637,195	A	1/1987	Davis
2,856,646	A	10/1958	Latimer et al.	4,648,216	A	3/1987	Reaves et al.
3,010,547	A	11/1961	Foster	4,706,422	A	11/1987	Ashton
3,037,593	A	6/1962	Webster	4,726,166	A	2/1988	DeRees
3,133,322	A	5/1964	Douglas	4,736,566	A	4/1988	Krotsch
3,143,827	A	8/1964	Showalter	4,794,746	A	1/1989	Ramer
3,160,245	A	12/1964	Pavlecka	4,799,339	A	1/1989	Kobori et al.
3,172,509	A	3/1965	Dugger	4,863,189	A	9/1989	Lindsay
3,206,903	A	9/1965	Johnson	4,875,314	A	10/1989	Boilen
3,300,926	A	1/1967	Heirich	4,879,160	A	11/1989	Knudson et al.
3,304,675	A	2/1967	Graham-Wood et al.	4,910,929	A	3/1990	Scholl
3,310,917	A	3/1967	Simon	4,918,900	A	4/1990	Fee et al.
3,328,927	A	7/1967	Kates	4,922,667	A	5/1990	Kobori et al.
3,360,892	A	1/1968	Rosso	4,937,993	A	7/1990	Hitchins
3,452,501	A	7/1969	Sickler et al.	4,937,997	A	7/1990	Thomas, Jr. et al.
3,474,582	A	10/1969	Wah et al.	5,056,577	A	10/1991	DeLong et al.
3,568,388	A	3/1971	Flachbarth	5,065,558	A	11/1991	Boatsman
3,612,291	A	10/1971	Skubie	5,070,661	A	12/1991	Lo Guidici
3,623,288	A	* 11/1971	Horowitz 52/264	5,072,570	A	12/1991	Johnson
3,633,327	A	1/1972	Klingernsmith et al.	5,218,803	A	6/1993	Wright
3,638,380	A	2/1972	Perri	5,271,197	A	12/1993	Uno et al.
3,657,849	A	4/1972	Garton	5,279,088	A	* 1/1994	Heydon 52/241
3,658,388	A	4/1972	Hasegawa	5,333,426	A	8/1994	Varoglu
3,668,828	A	6/1972	Nicholas et al.	5,345,716	A	9/1994	Caplan
3,724,078	A	4/1973	Carline et al.	5,350,265	A	9/1994	Kinner
3,744,197	A	7/1973	Wetzel, Jr.	5,353,560	A	10/1994	Heydon
3,748,799	A	7/1973	Tough et al.	5,375,384	A	12/1994	Wolfson
3,775,920	A	12/1973	Schneller	5,388,358	A	2/1995	Mazhar
3,820,295	A	6/1974	Folley	5,390,466	A	2/1995	Johnson et al.
3,822,521	A	7/1974	Lucas	5,417,026	A	5/1995	Brumfield
3,854,253	A	12/1974	Slowbe	5,426,893	A	6/1995	Hoffman
3,871,153	A	3/1975	Birim	5,457,927	A	10/1995	Pellock et al.
3,875,719	A	4/1975	Menge	5,467,570	A	11/1995	Leek
3,916,578	A	11/1975	Forootan et al.	5,491,950	A	2/1996	Obegi
4,016,697	A	4/1977	Ericson	5,499,480	A	3/1996	Bass
4,016,698	A	4/1977	Rogers	5,505,031	A	4/1996	Heydon
4,037,281	A	7/1977	Reynolds	5,524,406	A	6/1996	Ragland
4,037,379	A	7/1977	Ozanne	5,546,723	A	8/1996	Jones
4,037,381	A	* 7/1977	Charles 52/800.12	5,553,437	A	9/1996	Navon
4,040,232	A	8/1977	Snow et al.	5,579,615	A	12/1996	Hoffman
4,065,218	A	12/1977	Biggane	5,581,969	A	12/1996	Kelleher
4,069,635	A	1/1978	Gilb	5,617,693	A	4/1997	Hefner
4,074,487	A	2/1978	Daniels et al.	5,619,837	A	4/1997	DiSanto
4,078,352	A	3/1978	Knowles	5,628,495	A	5/1997	Gandara
4,114,333	A	9/1978	Jones et al.	5,640,824	A	6/1997	Johnson et al.
4,122,647	A	10/1978	Kovar	5,649,403	A	7/1997	Haisch
4,130,970	A	12/1978	Cable	5,651,229	A	7/1997	Wada et al.
				5,657,606	A	8/1997	Ressel et al.

5,664,388	A	9/1997	Chapman et al.	
5,692,353	A	12/1997	Bass	
5,706,614	A	1/1998	Wiley, Jr.	
5,706,626	A	* 1/1998	Mueller	52/800.12
5,713,176	A	2/1998	Hunt	
5,727,663	A	3/1998	Taylor	
5,729,950	A	3/1998	Hardy	
5,735,087	A	4/1998	Olden	
5,761,873	A	6/1998	Slater	
5,782,047	A	7/1998	De Quesada	
5,782,054	A	7/1998	Varoglu	
5,788,396	A	8/1998	Goto	
5,788,397	A	8/1998	Goto	
5,807,014	A	9/1998	Goto	
5,807,015	A	9/1998	Goto	
5,823,701	A	10/1998	Goto	
5,842,318	A	12/1998	Bass et al.	
5,845,438	A	12/1998	Haskell	
5,848,512	A	12/1998	Conn	
5,862,639	A	1/1999	Abou-Rached	
5,870,870	A	* 2/1999	Utzman	52/483.1
5,873,672	A	2/1999	Goto	
5,904,025	A	5/1999	Bass et al.	
5,906,451	A	5/1999	Goto	
D411,021	S	6/1999	Chapman et al.	
5,921,054	A	7/1999	Rudd	
5,924,815	A	7/1999	Goto	
5,937,607	A	8/1999	Li	
5,950,385	A	9/1999	Herren	
5,979,130	A	11/1999	Gregg et al.	
5,987,828	A	11/1999	Hardy	
5,996,292	A	12/1999	Hill et al.	
6,006,487	A	12/1999	Leek	
6,018,917	A	2/2000	Leek	
6,067,769	A	5/2000	Hardy	
6,073,413	A	6/2000	Tongiatama	
6,079,168	A	6/2000	Shaver	
6,109,850	A	8/2000	Commins	
6,148,583	A	* 11/2000	Hardy	52/693
6,158,184	A	12/2000	Timmerman, Sr. et al.	
6,185,898	B1	2/2001	Pratt	
6,192,637	B1	2/2001	Boilen et al.	
6,205,725	B1	3/2001	Butler	
6,212,849	B1	4/2001	Pellock	
6,240,695	B1	6/2001	Karalic	
6,244,004	B1	6/2001	Timmerman, Sr. et al.	
6,250,029	B1	6/2001	Jeffers et al.	
6,260,323	B1	7/2001	Hockey	
6,298,612	B1	10/2001	Adams	
6,298,617	B1	10/2001	de Quesada	
6,308,469	B1	10/2001	Leung	
6,327,831	B1	12/2001	Leek	
6,345,476	B1	2/2002	Hill	
6,385,942	B1	5/2002	Grossman et al.	
6,481,175	B2	11/2002	Potter et al.	
6,484,460	B2	11/2002	Van Haitsma	
6,560,940	B2	5/2003	Mueller	
6,615,896	B1	9/2003	Andalia	
6,643,986	B2	11/2003	Commins et al.	
6,662,506	B2	12/2003	Fischer et al.	
6,668,508	B2	12/2003	Boone et al.	
6,877,285	B2	4/2005	Poma et al.	
7,073,298	B1	7/2006	Phan	
7,251,920	B2	8/2007	Timmerman et al.	
2002/0002806	A1	1/2002	Commins et al.	
2002/0020122	A1	2/2002	Mueller	
2003/0009964	A1	1/2003	Trarup et al.	
2004/0068947	A1	4/2004	Commins et al.	
2005/0126105	A1	6/2005	Leek et al.	
2005/0284073	A1	12/2005	Leek et al.	
2007/0062135	A1	3/2007	Mueller	

FOREIGN PATENT DOCUMENTS

AU	A-23306/95	1/1996
CA	2,196,869	2/1996
DE	2,598,37	6/1912
DE	7,155,17	1/1996
EP	0 468 949 A1	6/1991
FR	2 599 408	12/1987

GB	2315288	A	1/1998
IT	419 526		3/1967
JP	S49-108213	A	10/1974
JP	54087616		6/1979
JP	S54-152319	A	11/1979
JP	S57-106810	U1	7/1982
JP	S57-143307	U1	9/1982
JP	60-122420		8/1984
JP	60-85144		5/1985
JP	S60-85144	A	5/1985
JP	S60-122420	U1	8/1985
JP	60-1224420	*	10/1985
JP	3208936		2/1990
JP	02049449		4/1990
JP	03199550		8/1991
JP	3-208936		9/1991
JP	4-83038		3/1992
JP	4-98908		8/1992
JP	5-44276		2/1993
JP	6-2358		1/1994
JP	6-322839		11/1994
JP	8-159121		6/1996
JP	H-08-284295	A	10/1996
JP	8-296278		11/1996
JP	8-302861		11/1996
JP	9-256738		9/1997
JP	9-273214		10/1997
JP	9-279684		10/1997
JP	10-140653		5/1998
JP	10-184076		7/1998
JP	63-039297		10/1998
JP	11229490		8/1999
JP	2003293487		10/2003
NZ	186060		11/1980
NZ	221612		3/1993
WO	WO 96/02713		2/1996

OTHER PUBLICATIONS

ICBO Evaluation Service, Inc. Report: STS Prefabricated Lateral-Force Resisting (LFR) Panel System. Jul. 1, 1998.

Acceptance Criteria for Prefabricated Wood Shear Panels, ICBO Evaluation Service, Inc., Jul. 1997, U.S.A.

STS Prefabricated Lateral-Force Resisting (LFR) Panel System Evaluation Report, ICBO Evaluation Service, Inc. Jul. 1, 1998.

John R. Tissell, Wood Structural Panel Shear Walls, May 1993, Report 154, APA Engineered Wood Association, U.S.A.

Greg C. Foliente, Earthquake Performance and Safety of Timber Structures, Forest Products Society, Madison WI pp. 120-124.

Z-Wall Delivers Strength, Honolulu, Hawaii.

The Hardy Frame, Brochure.

Go-Panel, Brochure.

ShearMax Panel, Brochure.

Thallon, Rob. Graphic Guide to Frame Construction. Sep. 1991. pp. 70, 77, 79-82. The Taunton Press, Newtown, CT.

American Plywood Association, 1992. APA Homeowner's Guide to Earthquake Safeguards. Selected Web Pages, 13 pgs.

Simpson Strong-Tie co., Inc. Copyright 1991. Total 16 pages Connectors for Earthquake Retrofit and New Construction.

Breyer, Donald E. Design of Wood Structures. 1993. Chapter 3, §§ 3.1, 3.3, 3.4 and Chapter 10.

Japanese Language Newspaper Article, 1 pg.

Japanese Language Magazine Article, "Wide Focus", 2 pgs. p. 20 and 21.

Color Photocopies, "Wood Framed Residential Project in Kobe Japan Utilizing MFG. LWM Steel Shear Panels", 4 pgs, 1996.

Paul Polikapo Tongiatama, Provisional Specification "PT BRACE" Dated: Jun. 28, 1994.

James A. Adams, "Z-Wall," U.S. Appl. No. 60/003,181, filed Sep. 5, 1995 (Honolulu, Hawaii).

"Temblor spurs builder to create anti-quake frame," Daily Press (Victorville, California), p. A-4 (1pg), (Apr. 26, 1999).

"P.T. Brace," Roll Form Industries Pty Ltd (Acacia Ridge, Old.), (2 pgs).

Simpson Strong-Tie Company, Inc. Catalogue, "Handbook of Structural Designs & Load Values," Strong-Tie Timber Connectors (2pgs), (Sep. 20, 1978).

- Donald E. Breyer, "Design of Wood Structures," 3rd ed., McGraw-Hill, Inc., (100 pgs), (Dec. 20, 1993), Chapters 8, 9, 11 & Sections 12.1, 12.9.
- U.S. Appl. No. 60/043,835, filed on Apr. 4, 1997, "Lateral Force Resisting System," invented by Timothy L. Timmerman.
- Simpson Strong-Tie Company, Inc., "LTP/A34/A35 Framing Anchors," Simpson Strong-Tie Connectors, Simpson Strong-Tie Company, Inc. (U.S.A.), numbered p. 58, (1995).
- Simpson Strong-Tie Company, Inc., "CS/CMST Coiled Straps," Simpson Strong-Tie Connectors, Simpson Strong-Tie Company, Inc. (U.S.A.), numbered p. 56, (1995).
- Edward L. Keith, P.E., "153 Big Bin: Performance and Testing," Research Report American Plywood Association, American Plywood Association (Tacoma, Washington U.S.A.), front cover, numbered 1-24, back cover, (May 1990).
- Ben L. Schmid Calculation Sheet, "Apartment Bldgs Seismic Strengthening," total of 1 page, (Jul. 30, 1994).
- John R. Tissell, P.E and John D. Rose, "146 Roof Diaphragms for Manufactured Homes," Research Report American Plywood Association, Technical Services Division, American Plywood Association (Tacoma, Washington U.S.A.), front cover, numbered pp. 3-30, back cover, (Revised Sep. 1993).
- American Plywood Association; "Stapled Sheet Metal Blocking for APA Panel Diaphragms," Technical Note American Plywood Association No. N370B, American Plywood Association (Tacoma, Washington, U.S.A.), total of p. 1, printed both sides (Revised Nov. 1993).
- American Plywood Association, "Materials Handling," APA The Engineered Wood Association Industrial Use Guide, American Plywood Association (Tacoma, Washington U.S.A.), front cover, numbered pp. 3-54, back cover (Revised Jan. 1995).
- American Plywood Association, "The Produce Protector Making a Case for Plywood Harvest Bins," APA The Engineered Wood Association, American Plywood Association (Tacoma, Washington U.S.A.), total of 1 page, printed both sides (May 1996).
- American Plywood Association, "A Test of Time Plywood Harvest Bins Span Three Decades in Use," APA The Engineered Wood Association, American Plywood Association (Tacoma, Washington U.S.A.), total of 1 page, printed both sides (Nov. 1996).
- American Plywood Association, "APA Collapsible Bin Design and Fabrication," APA The Engineered Wood Association, American Plywood Association (Tacoma, Washington U.S.A.), front cover, numbered pp. 2 and 3, back cover, (Feb. 1997).
- American Plywood Association, "Plywood for Tobacco Storage," APA The Engineered Wood Association, American Plywood Association (Tacoma, Washington U.S.A.) total of 1 page, (at least as early as 1997).
- Alfred D. Commins and Robert C. Gregg, "Cyclic Performance of Tall-Narrow Shearwall Assemblies," total of 12 pages, (Apr. 5, 1994).
- Forest Products Society, "Earthquake Performance and Safety of Timber Structures," Forest Products Society (Madison, WI), (1997).
- Donald E. Breyer, "Design of Wood Structures," 3rd Ed., Chapter 8, Plywood and Other Structural-Use Panels, McGraw-Hill, Inc. (New York, NY U.S.A.), front page, back page and p. 434.
- Simpson Strong-Tie Company, Inc., "Wood Construction Connectors," Catalog C-97, Simpson Strong-Tie Company, Inc. (U.S.A.), front page, back page and p. 53, (Jan. 1, 1997).
- Typical CS Installation as a Floor-to-Floor Tie with Strap Attached Over Plywood, total of 1 page.
- Donald E. Breyer, "Design of Wood Structures," 3rd Ed., Chapter 10, Shearwalls, McGraw-Hill, Inc. (New York, NY U.S.A.), front page, back page, and p. 497-532.
- "BULLDOG Timber Connectors. Develop Full Strength of Timber Members at Connections", Product brochure. Publication date unknown, received in the offices of James R. Cypher Oct. 24, 1997, BULLDOG A/S, Oslo, Norway.
- "BULLDOG Steel Safety Timber Connectors." Product data. 1938. O. Theodorsen, C. E., Oslo, Norway.
- "Hurri-Bolt Uplift Solutions. The Truss Tie-Down That Will Blow You Away. Engineering Manufacturing & Installation. SBCCI Report #9910," Product brochure. Publication date unknown; received in the offices of James R. Cypher Jul. 28, 1999. Hurri-Bolt Uplift Solutions, Inc. Tampa, Florida.
- Evaluation Report ER-5467. Rayco Earthquake Mitigation Anchor System. Nov. 1, 1998. ICBO Evaluation Service, Inc., Whittier, California.
- Evaluation Report PFC-5342. Hard Frame, Hardy Frame Heavy Duty, 18-Inch Hard Braced Frame and Hardy Frame Screw. Sep. 1, 1999. ICBO Evaluation Service, Inc. Whittier, California.
- MBR TDSsystem "Typical Component Installation Details." Installation Instructions and product data. Jun. 9, 1993, MBR Systems, South San Francisco, California.
- PROBOLT, "Structural Tie Down System." Product data sheet, installation instructions, and SBCCI Report No. 9916. 1999. PROBOLT, Orlando, Florida.
- "Seismic Solutions Structural Tie Downs. Quake-Tie. The Superior Hold-Down Solution." Product brochure and data sheet. Jan. 1998.
- "Memorandum re Calculation of Wood Shrinkage for Proposed Quake-Tie Hold-down System Consideration." Jan. 20, 1997. Seismic Solutions, Glen Ellen, California.
- "Simplified Structural Systems. Makers of The Hardy Frame." Product brochure. Dec. 1, 1999. Simplified Structural Systems, Ventura, California.
- "Simpson Strong-Tie Connectors. Strong-Wall Shearwall." Product data. 1999. Simpson Strong-Tie Company, Inc., Pleasanton, California.
- "Simpson Strong-Tie Connectors. Strong-Wall Shearwall." Installation guide. 2001. Simpson Strong-Tie Company, Inc., Pleasanton, California.
- "MKP Monkey Paw Anchor Bolt Holders." "LBP/BP Bearing Plates." "RFB Retrofit Bolts." *Wood Construction Connectors*. Catalog C-96. 1995. Simpson Strong-Tie Company, Inc., Pleasanton, California. p. 19.
- Dunkley, D.. "Prefab Shear Walls." *The Journal of Light Construction*. vol. 18, No. 3. Dec. 1999. pp. 46-53.
- "Every Home Needs Z-Walls. The Strongest Shear Wall in the Smallest Space." Product brochure. Date unknown. KC Metal Products, Inc. San Jose, California.
- "ZWALL Shear Walls. Strength Where You Need It." Product data on-line. Retrieved from the internet Jun. 13, 2001 from URL: <http://www.z-wall.com/photo15.htm>, <http://www.z-wall.com/photo7.htm>, and <http://www.z-wall.com/diag15.htm>.
- Foliente, G.C., ed. *Earthquake Performance and Safety of Timber Structures*. Forest Products Society. Madison, Wisconsin. 1997. (See in particular: Karalic, M. "Analysis of Performance of Floors and Shear Walls with the New Engineered Bracing Systems," pp. 115-124 and Commins, A. et al., "Effect of Hold-Downs and Stud-Frame Systems on the Cyclic Behavior of Wood Shear Walls," pp. 142-146).
- Utzman, Charles H. Provisional Patent application entitled, "Shear Panel Joint".
- Affidavit of Karen colonias Regarding Testing of Third Party Products by Simpson Strong-Tie.
- Concise Drafting Services, Various letters, drawings and a brochure from Roll Form Industries Pty, Ltd. Authors: Paul Tongiatama, E. La Monaca, J. House and Roll Form Industries.
- Office Action dated Aug. 21, 2007, U.S. Appl. No. 10/705,662.
- Patty Christofferson, Tests of Narrow Plywood Shear-wall Panels Reveal Lack of Rigidity of Hold-down Anchorage, Structural Engineer's Association of Northern California Research Committee—Research Bulletin Board, Jan. 1994, B-1, BB94-1, Structural Engineers Association of Northern California, San Francisco, CA.
- Cyclic Testing of Narrow Plywood Shear Walls, ATC R-1, 1995, Applied Technology Council, Redwood City, CA.
- Lee W. Mueller, *Corrugated Diaphragm Shear Panel*, U.S. Appl. No. 60/215,290, filed Jun. 30, 2000.
- Craig J. Miller, *Light Gage Steel Infill Panels in Multistory Steel Frames*, *Engineering Journal*, 1974, pgs. 42-47, 2nd Quarter, American Institute of Steel Construction, Chicago, Illinois, United States.
- Yasuhiko Takahashi, Toshikazu Takeda, Yasushi Takemoto, Masatoshi Takagi, *Experimental Study on Thin Steel Shear Walls and Particular Steel Bracings under Alternative Horizontal Load*, Reports of the Working Commissions, Symposium: Resistance and Ultimate Deformability of Structures Acted on by Well Defined Repeated Loads, 1973, pp. 185-190, vol. 13, International Association for Bridge and Structural Engineering, Lisboa, Spain.

Vincent Caccese, Mohamed Elgaaly, Ruobo Chen, *Experimental Study of Thin Steel-Plate Shear Walls under Cyclic Load*, Journal of Structural Engineering, Feb. 1993, pp. 573-587, vol. 119, No. 2, American Society of Civil Engineers, Reston, Virginia, United States.

Mohamed Elgaaly, Yinbo Liu, *Analysis of Thin-Steel-Plate Shear Walls*, Journal of Structural Engineering, Nov. 1997, pp. 1487-1496, vol. 119, No. 11, American Society of Civil Engineers, Reston, Virginia, United States.

Mohamed Elgaaly, Vincent Caccese, C. Du, *Postbuckling Behavior of Steel-Plate Shear walls Under Cyclic Loads*, Journal of Structural

Engineering, Feb. 1993, vol. 119, No. 2, American Society of Civil Engineers, Reston, Virginia, United States.

Mohamed Elgaaly, Vincent Caccese, *Steel Plate Shear Walls*, Proceedings of the 1990 National Steel Construction Conference, copyright 2003, pp. 4-1—4-28, American Institute of Steel Construction, Chicago, Illinois, United States of America.

Chen, W.F., Handbook of Structural Engineering, 1997, pp. 1-1 through 1-27, 2-1 through 2-7, 2-117 through 2-164, 3-1 through 3-4, 3-49, 3-50, 5-1 through 5-83, 7-49 through 7-53, 8-5, 8-6, 19-1 through 19-23, CRC Press LLC, Boca Raton.

* cited by examiner

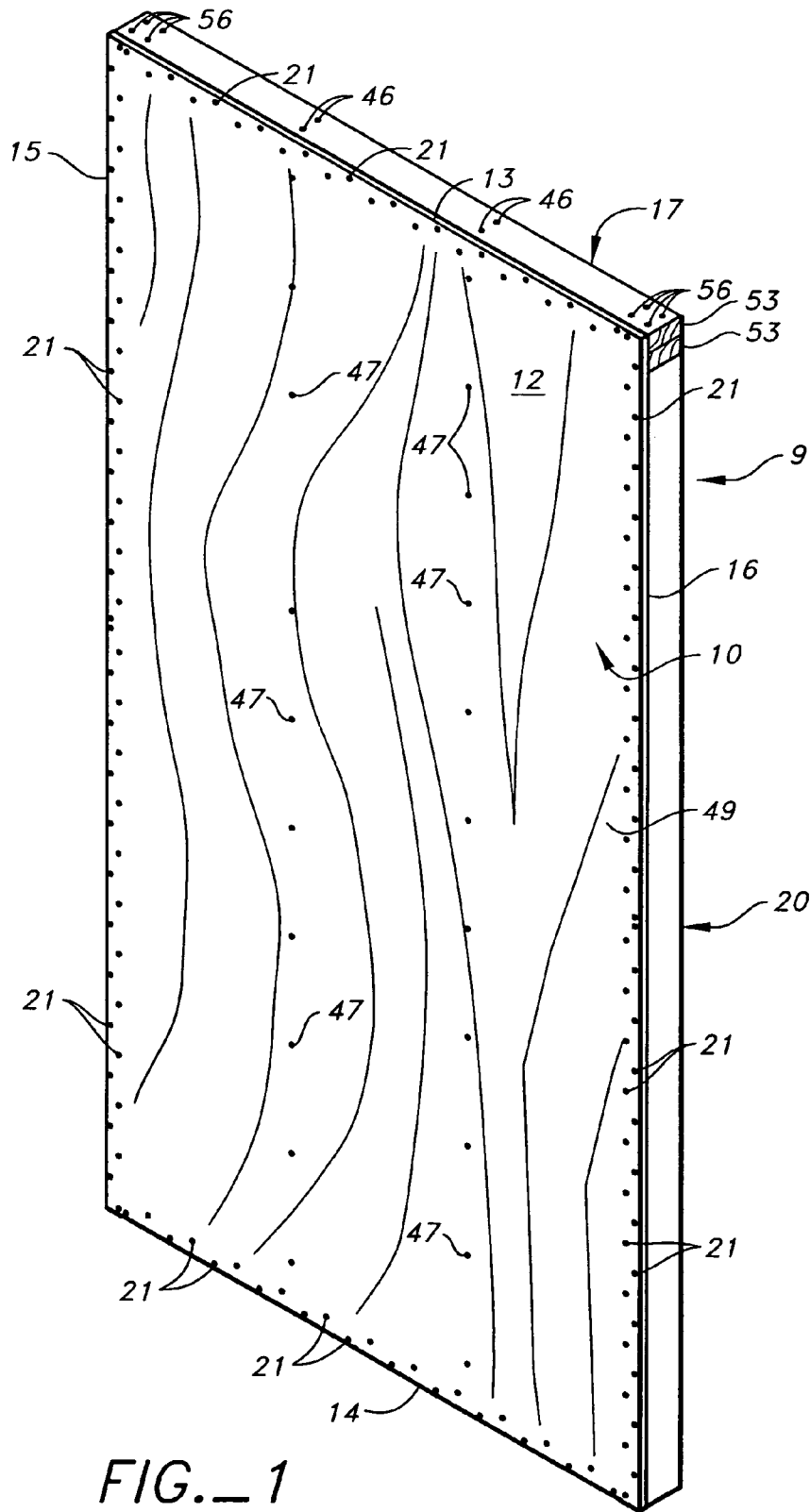

FIG. 1

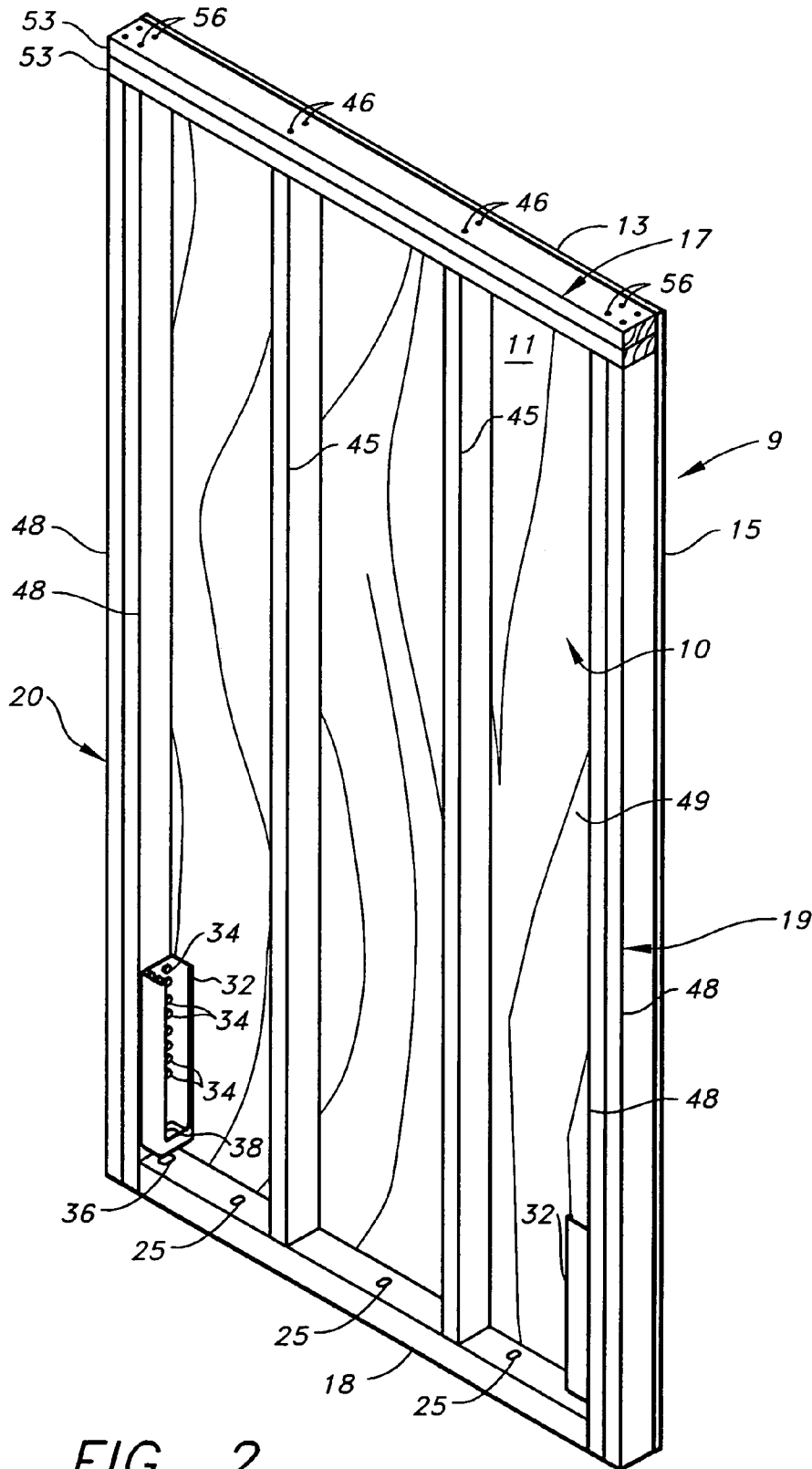

FIG. 2

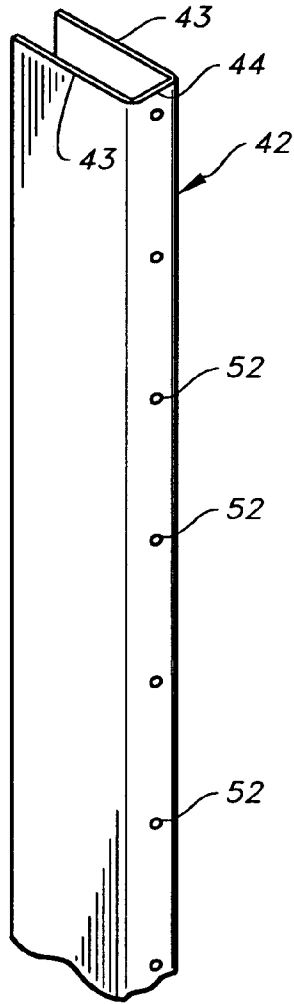

FIG. 3

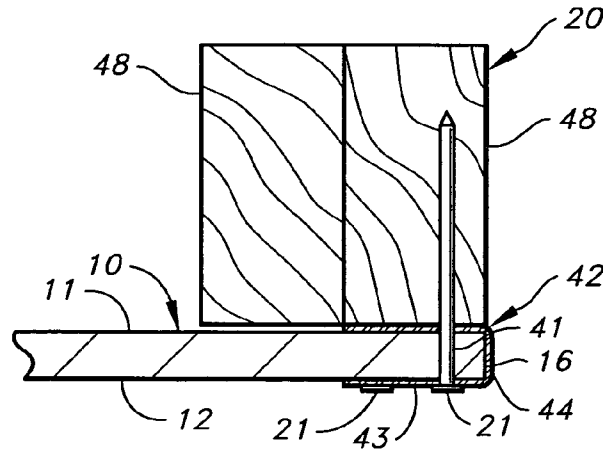

FIG. 4

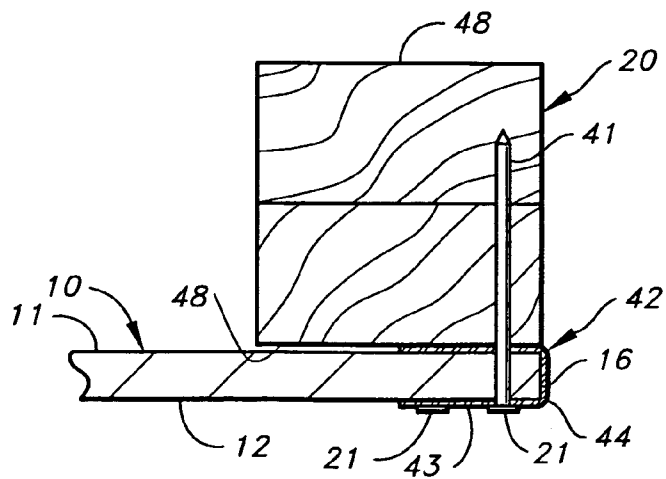

FIG. 5

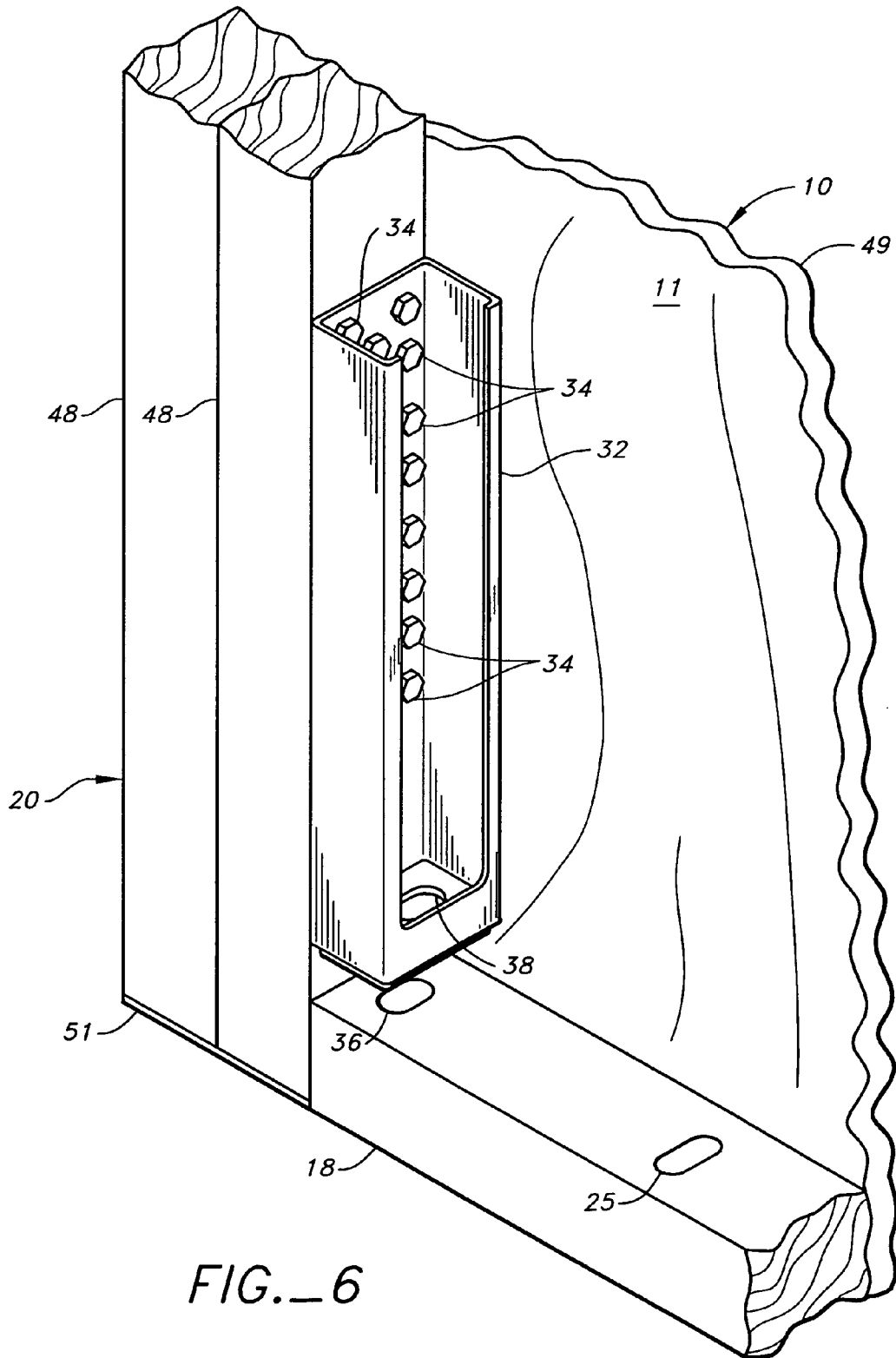

FIG. 6

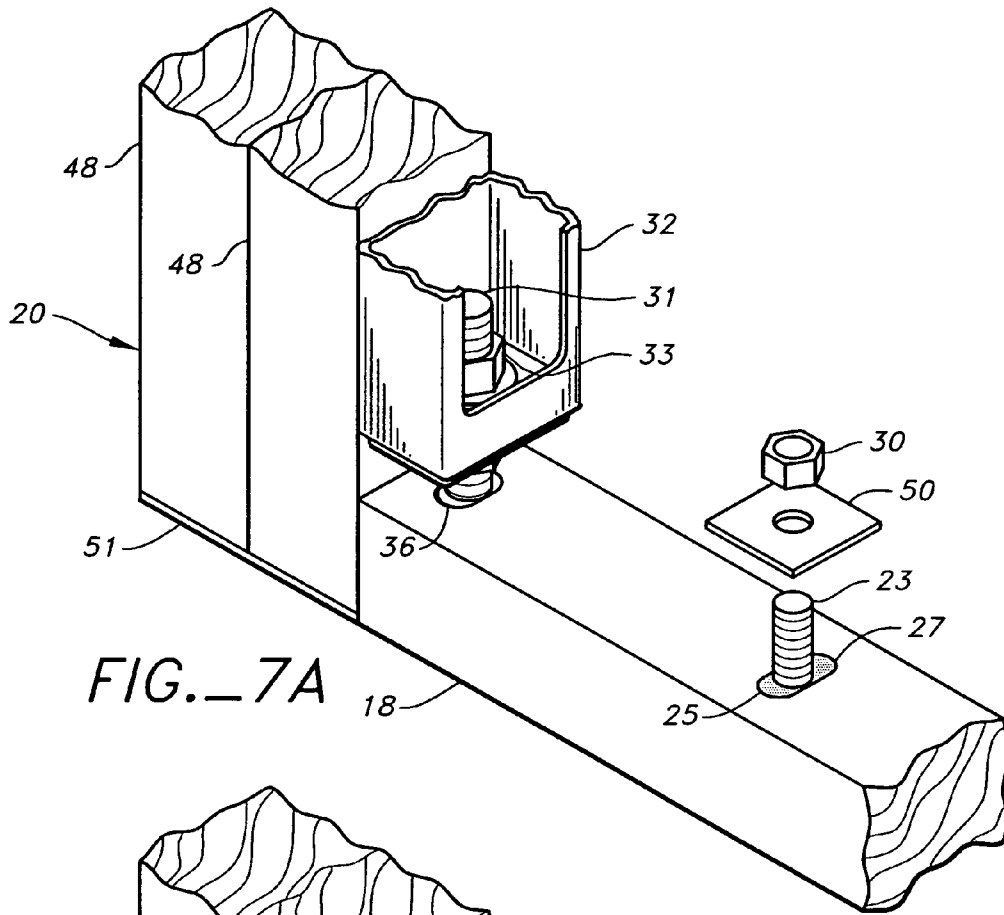

FIG. 7A

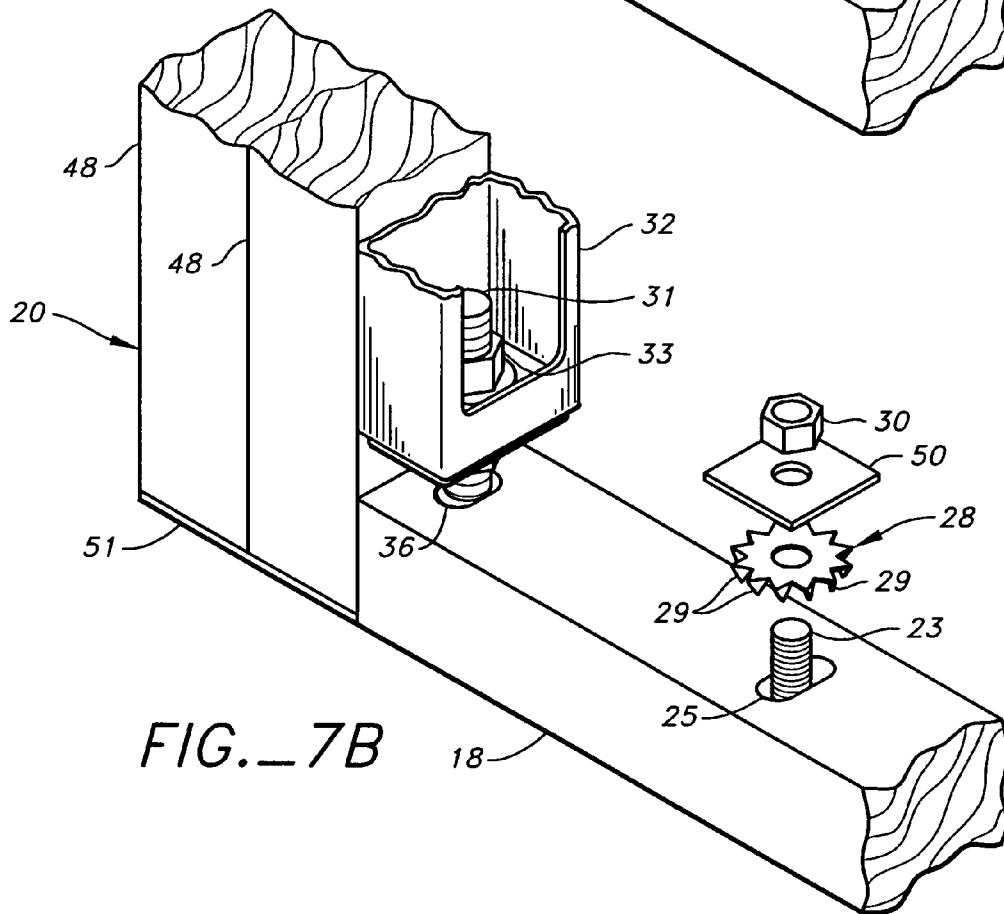

FIG. 7B

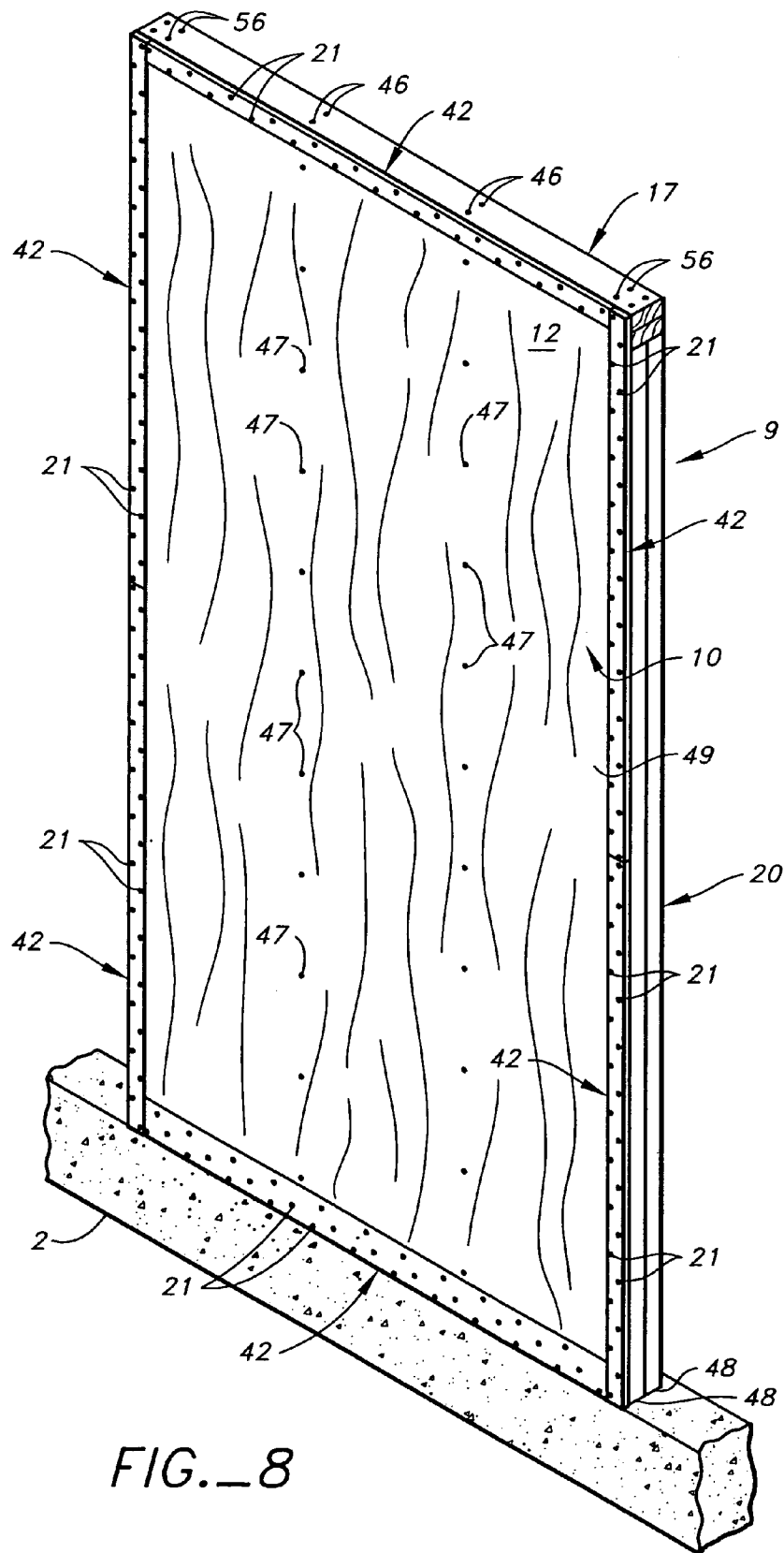

FIG. 8

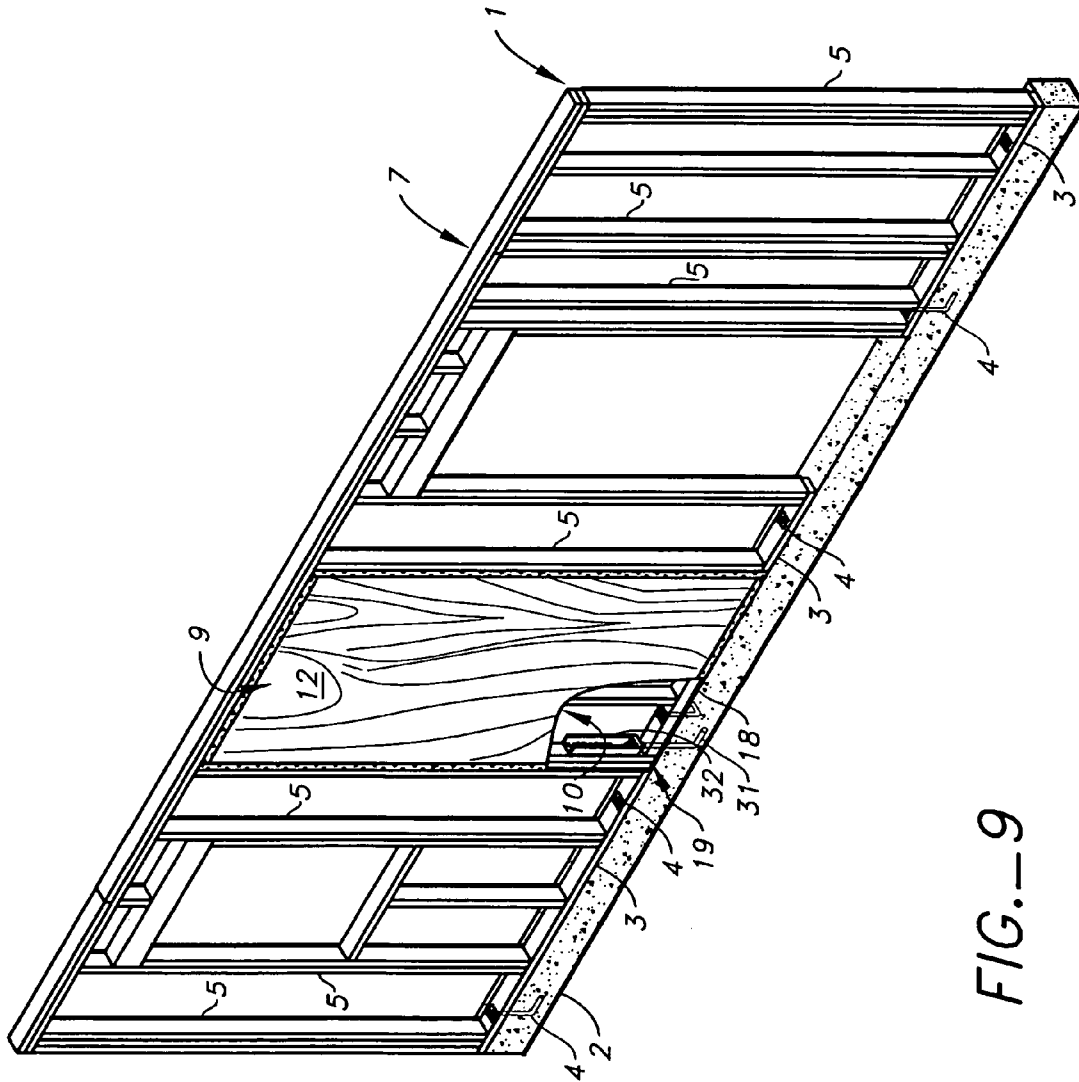

FIG.—9

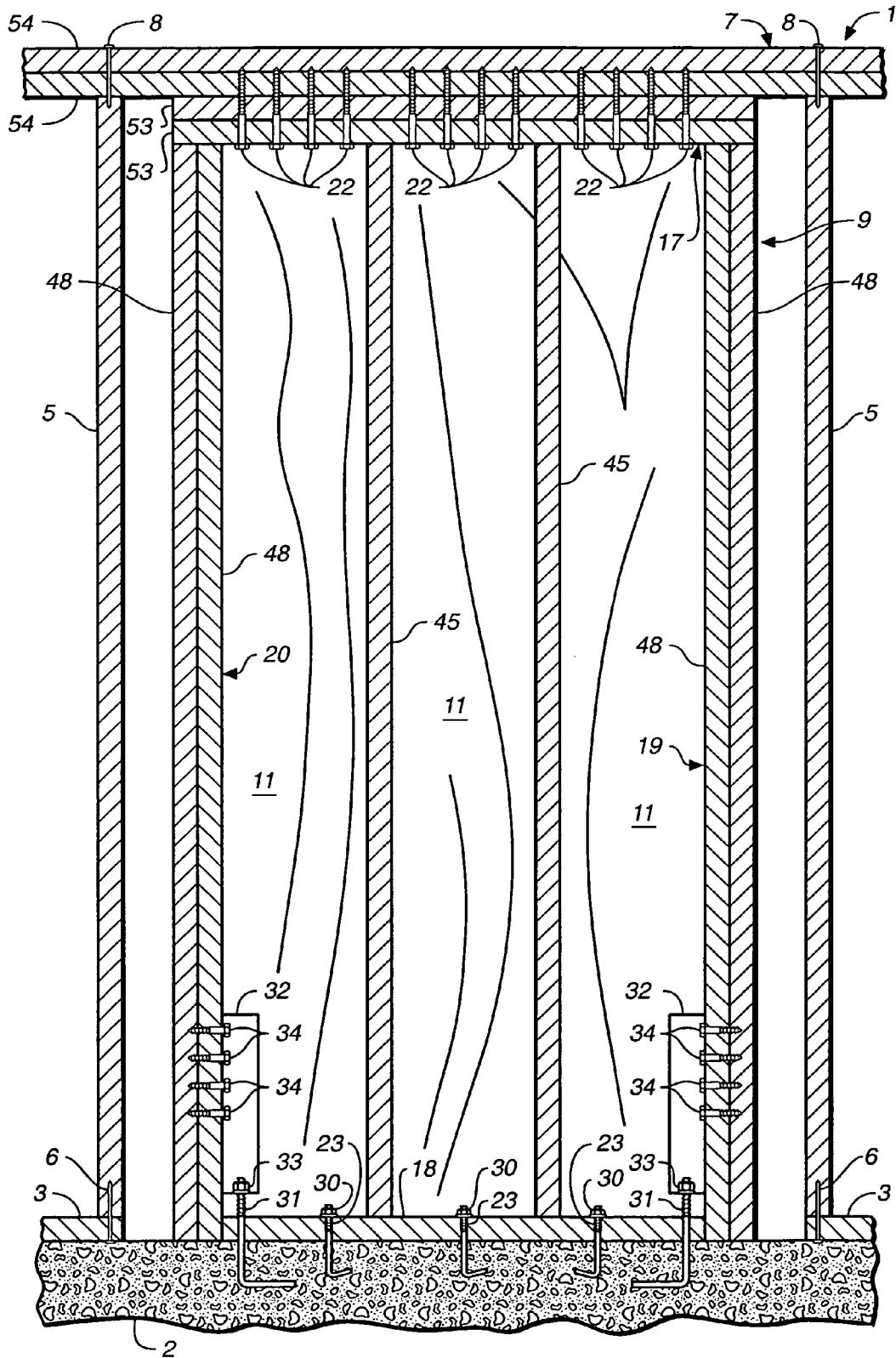

FIG. 10

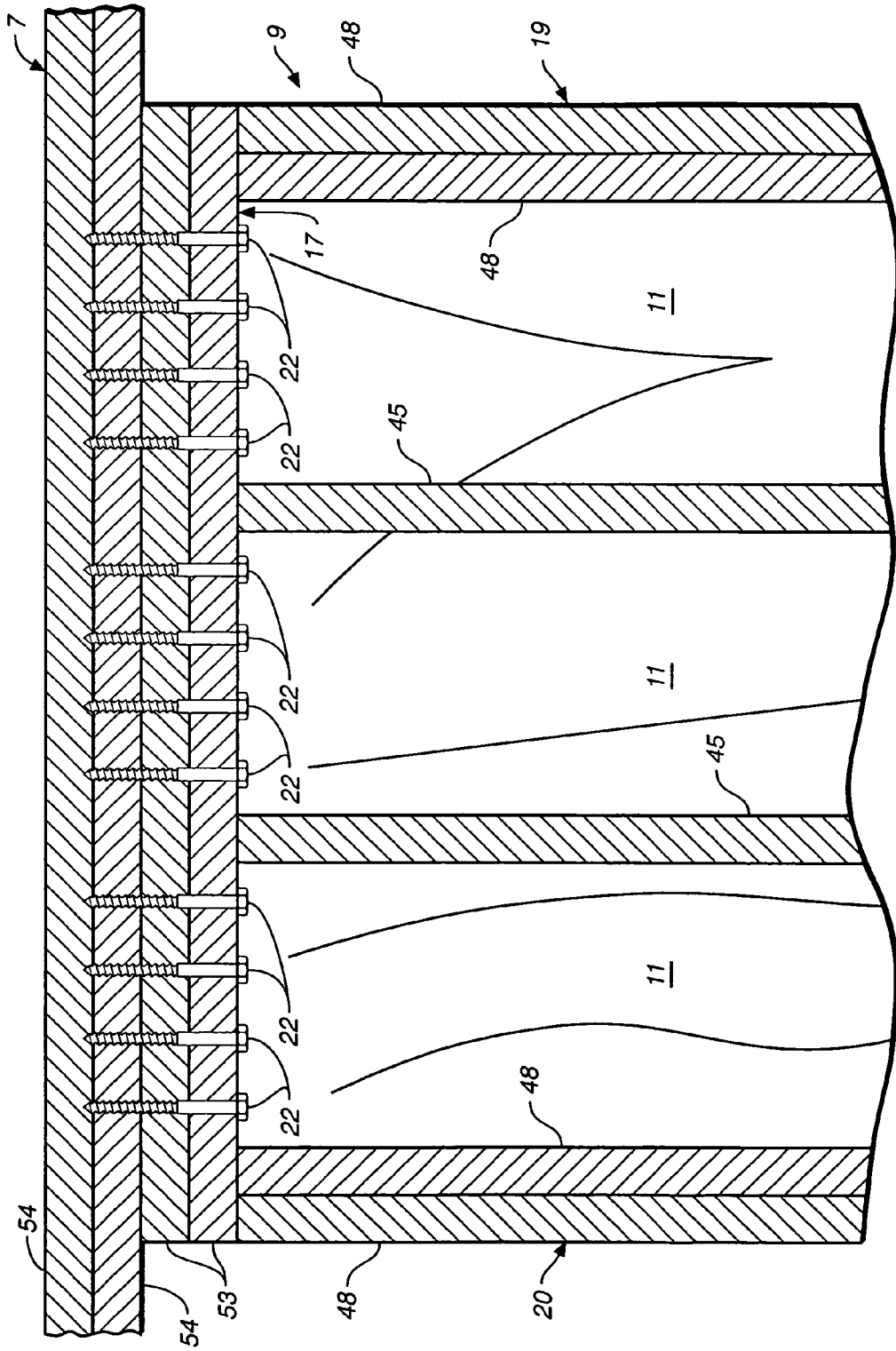

FIG. 10A

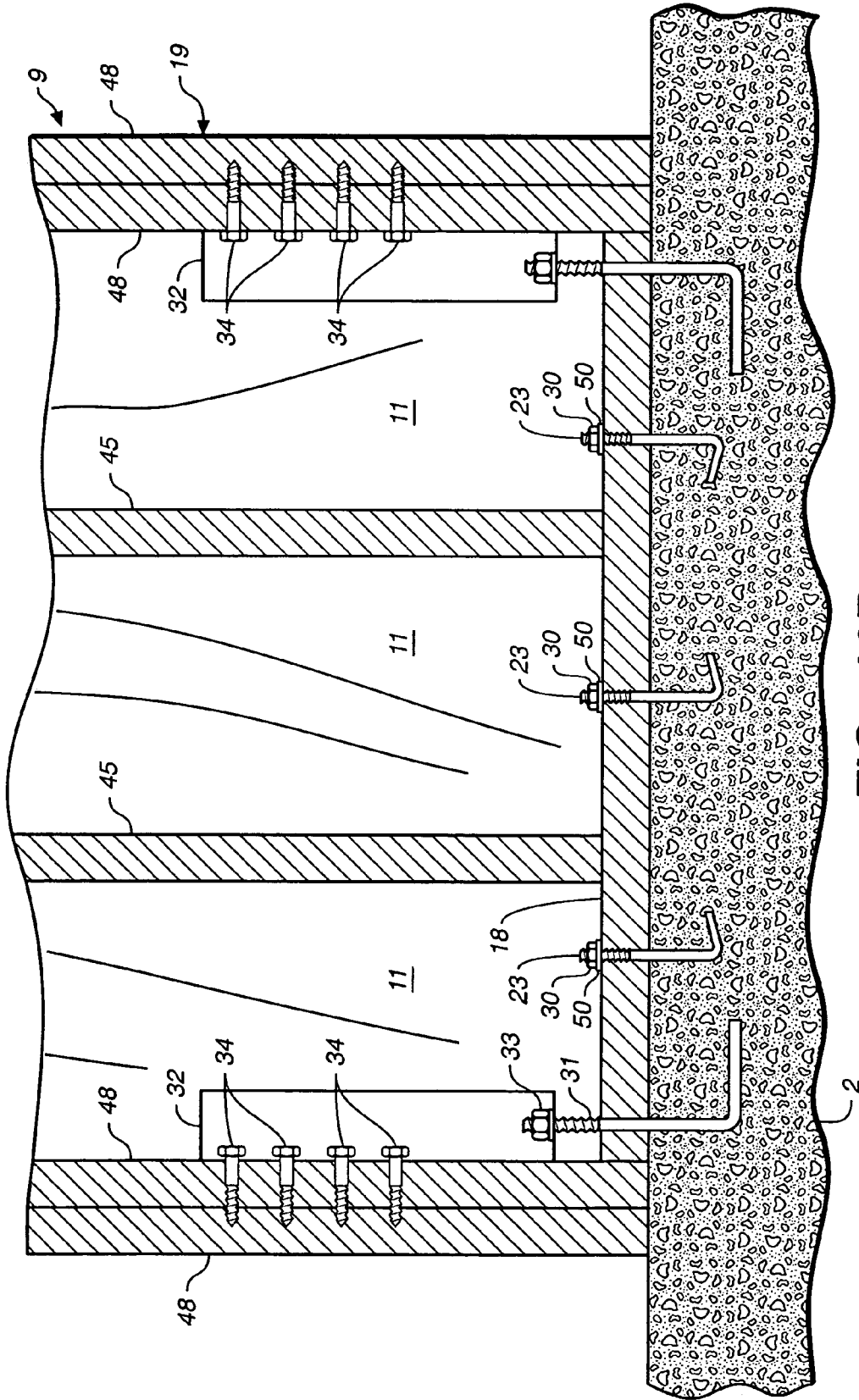
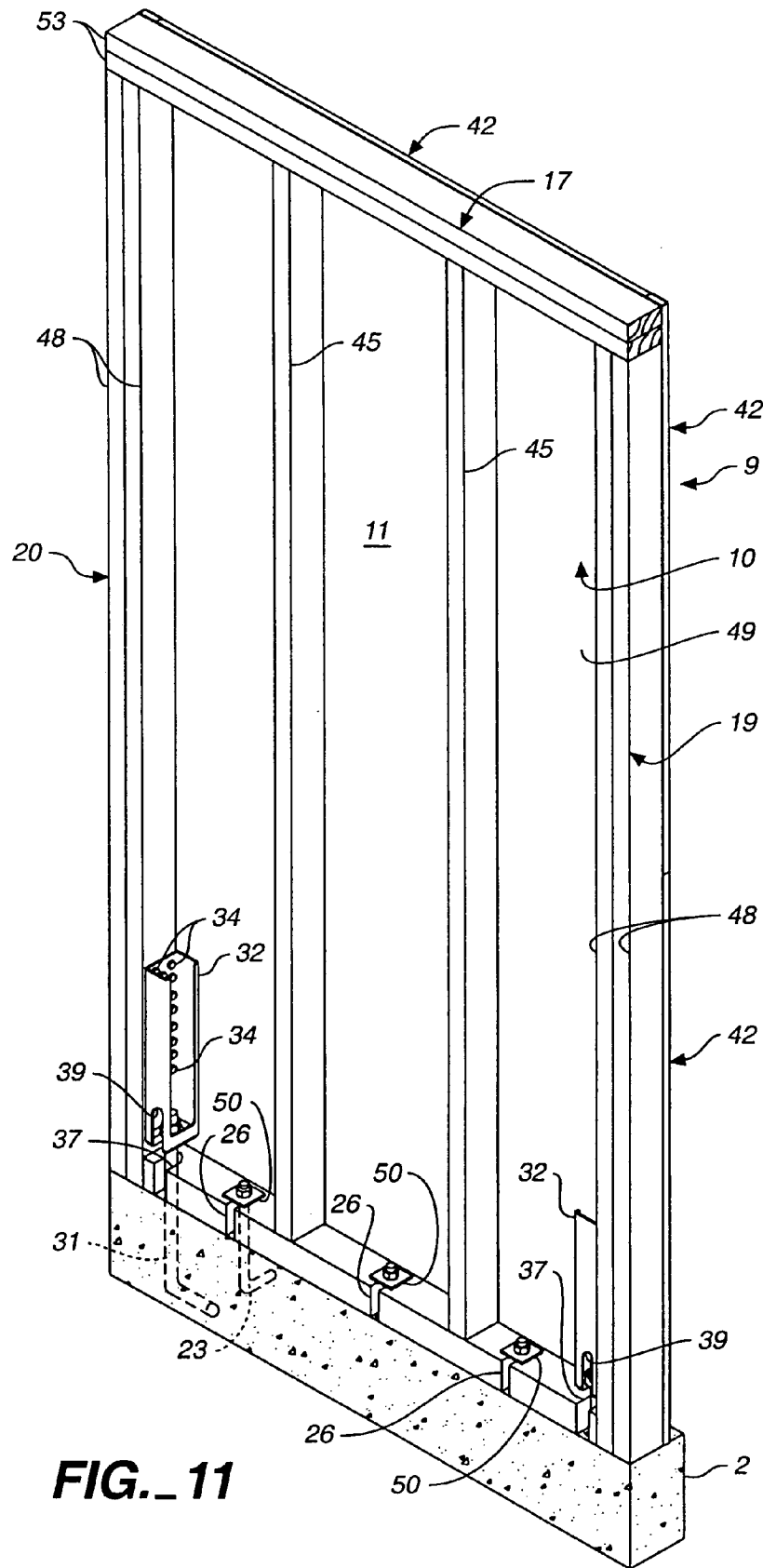

FIG. 10B



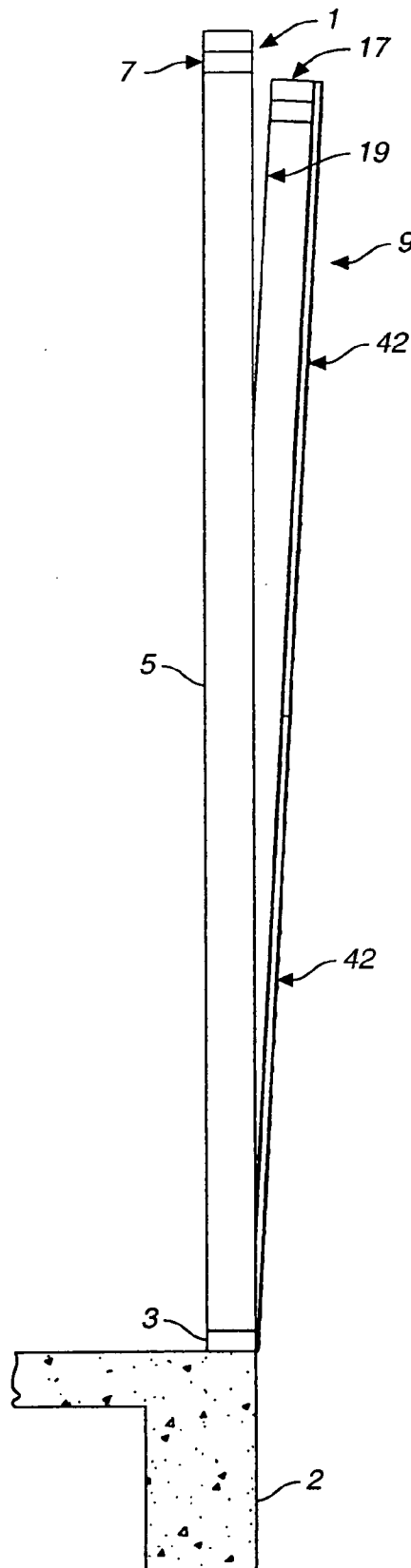

FIG. 12

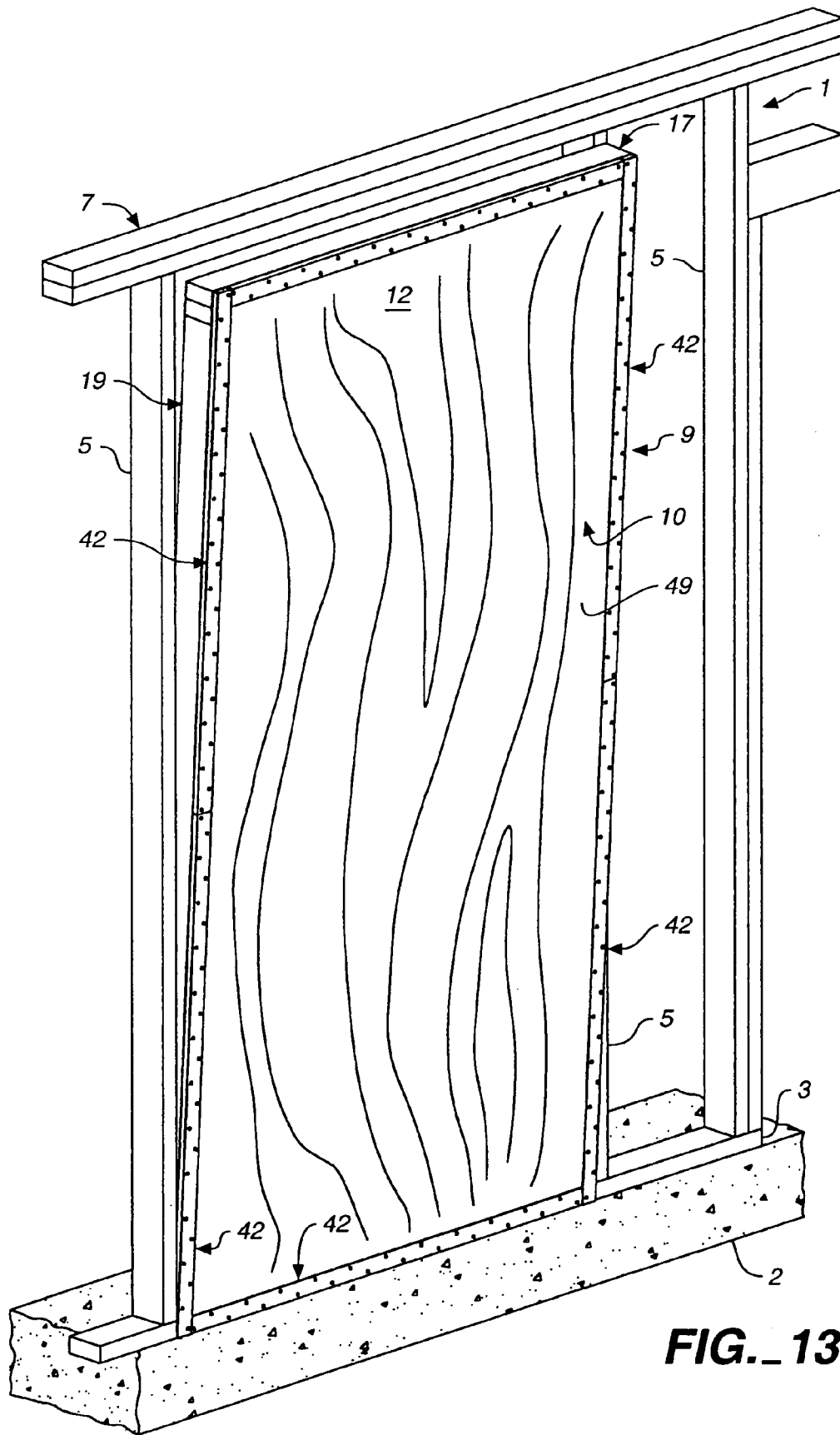

FIG. 13

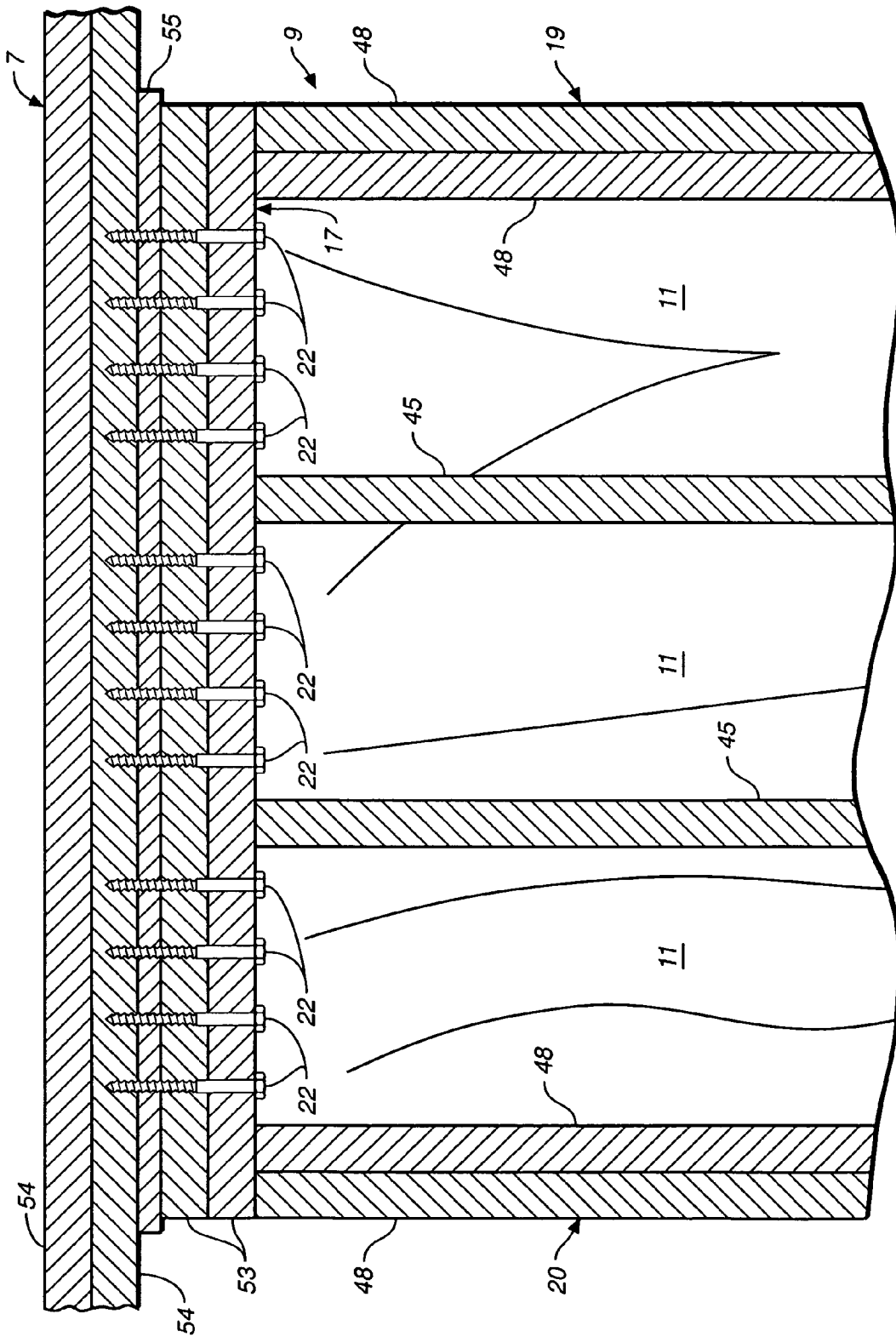

FIG. 14

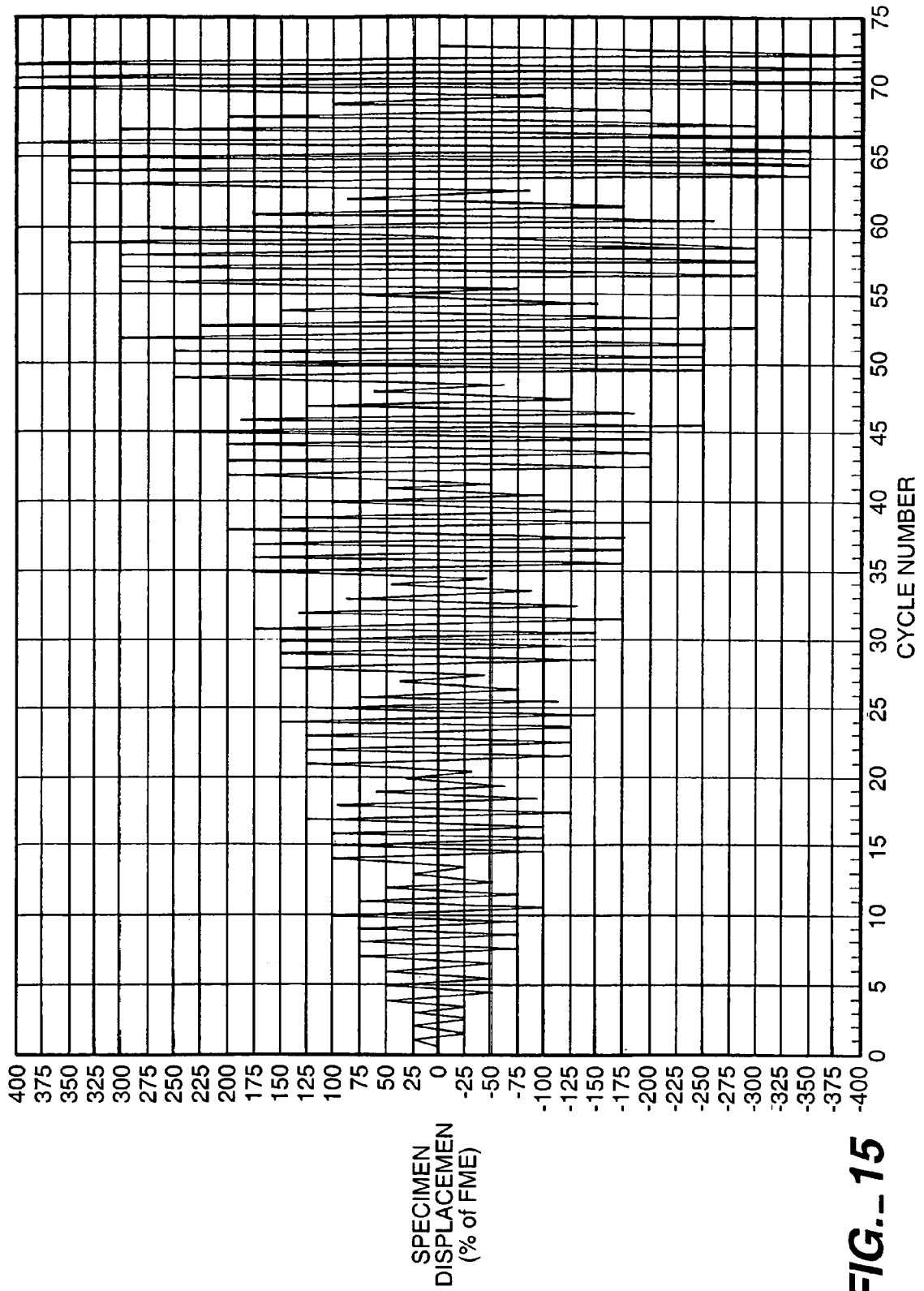

FIG. 15

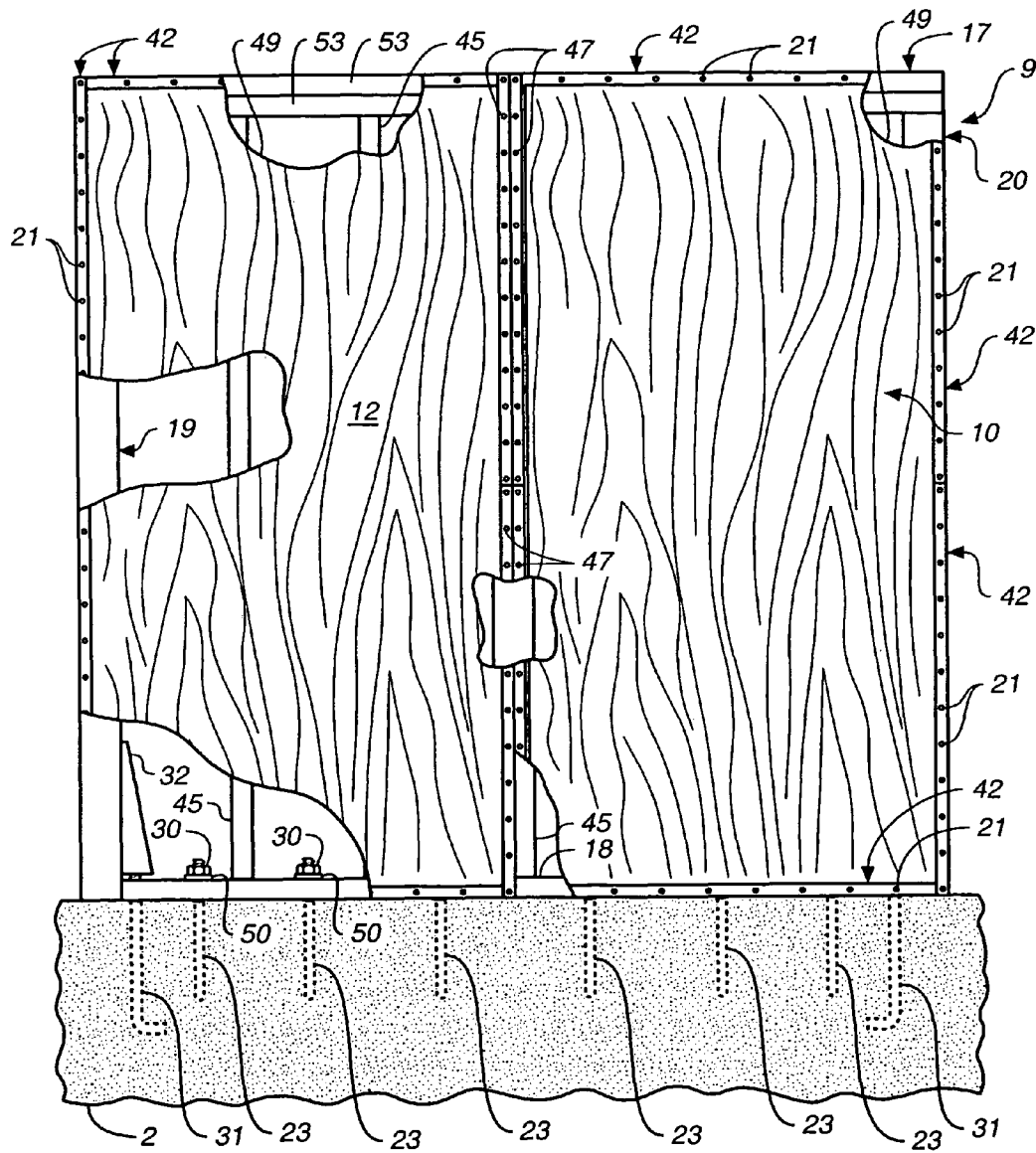

FIG. 16

BUILDING WALL FOR RESISTING LATERAL FORCES

BACKGROUND

This invention relates to an improved wall for resisting lateral forces imposed on a building incorporating the improved wall. Specifically, this invention relates to a wall in a light-frame building having within it a sub-component specifically designed to resist lateral forces imposed on the building such as those caused by an earthquake or by wind loading. The present invention improves on precedent wall designs in light-frame construction by providing a structure that the designer can confidently predict will resist the lateral forces for which it is designed.

All structures must be designed to resist lateral forces. Current methods for improving the lateral resistance of light-frame construction walls have focused on adding components to a wall built according to conventional practices. In light-frame construction, the simplest such wall consists of a bottom plate, studs resting on and connected to the bottom plate, and a top plate resting on and connected to the studs. Openings for windows and doorways may be incorporated into the light-frame wall.

One of the earliest methods for bracing a wall against lateral forces was to incorporate bracing into the frame of the wall in the form of diagonal bracing members. Another simple means of providing lateral resistance was to provide sheathing to the frame. Plywood sheathing and Oriented Strand Board are common sheathing materials used today in conventional light-frame construction.

As light-frame construction design became more sophisticated, foundation anchors were added to connect the bottom plate of the wall to the foundation to prevent the wall from slipping off the foundation. Later on it was realized that certain walls were light enough to lift up under moment reactions caused by lateral forces and so needed to be further anchored with brackets called holdowns, which attach to the studs of the wall and to bolts set into the foundation.

With proper design and installation, these conventional methods of providing lateral resistance by applying sheathing, foundation anchors and anchored holdowns to conventional walls can provide acceptable resistance to most lateral forces. However, proper installation can be a problem using conventional methods. The division of labor on job sites can result in improper connections. Furthermore, the installer may cut corners and sacrifice resistance to lateral forces in return for ease of installation or aesthetic considerations.

The present invention improves on conventional methods for providing lateral resistance by minimizing the possibility of variation in the installation of the component that will be responsible for providing lateral resistance.

OBJECTS OF THE INVENTION

It is an object of the present invention to provide a wall in a building that, as installed, can achieve specific design loads for resisting lateral forces on the wall.

It is an object of the present invention to provide a wall able to resist shearing forces on a building that is easy and economical to construct.

BRIEF DESCRIPTION OF THE DRAWINGS

FIG. 1 is a perspective view of the shear-resisting assembly of the present invention, showing the distal face of the shear-resisting element.

FIG. 2 is a perspective view of the shear-resisting assembly of the present invention, showing the proximal face of the shear-resisting element.

FIG. 3 is a perspective view of a portion of a boundary edging member of the present invention.

FIG. 4 is a top, sectional view of a portion of a shear-resisting assembly made according to the present invention, showing the shear-resisting element attached to the second chord by means of nails. A boundary edging member is shown embracing the second side edge of the shear-resisting element.

FIG. 5 is a top, sectional view of a portion of a shear-resisting assembly made according to the present invention, showing the shear-resisting element attached to the second chord by means of nails. A boundary edging member is shown embracing the second side edge of the shear-resisting element.

FIG. 6 is a perspective view of a portion of the shear-resisting assembly made according to the present invention. A first holdown is shown attached to the first chord by means of holdown fasteners. The first chord is shown with a standoff plate.

FIG. 7A is a perspective view of a portion of the shear-resisting assembly made according to the present invention. Also shown are a foundation anchor and a first anchor bolt that attaches the shear-resisting assembly to the underlying structural component. The slotted opening for the foundation anchor in the bottom strut is shown filled with epoxy.

FIG. 7B is a perspective view of a portion of the shear-resisting assembly made according to the present invention. Also shown are a foundation anchor and a first anchor bolt that attaches the shear-resisting assembly to the underlying structural component. A toothed plate is also shown that fits over the foundation anchor.

FIG. 8 is a perspective view of the shear-resisting assembly of the present invention, showing the distal face of the shear-resisting element. The shear-resisting assembly is shown resting on the underlying structural component. The shear-resisting assembly is shown with boundary edging members.

FIG. 9 is a perspective view of a wall built according to the present invention. A portion of the shear-resisting element is shown cut away to reveal a second holdown attached to the second chord of the shear-resisting assembly.

FIG. 10 is a front, cross-sectional view of a portion of a wall built according to the present invention.

FIG. 10A is a front, cross-sectional view of a portion of a wall built according to the present invention, showing the upper portion of the shear-resisting assembly.

FIG. 10B is a front, cross-sectional view of a portion of a wall built according to the present invention, showing the lower portion of the shear-resisting assembly.

FIG. 11 is a perspective view of the shear-resisting assembly of the present invention attached to the underlying structural component by means of foundation anchors and first and second anchor bolts. The proximal face of the shear-resisting element is shown. The bottom strut is shown with notched openings.

FIG. 12 is a side view of a wall of the present invention under construction. The shear-resisting assembly is shown being tilted into the wall.

FIG. 13 is a side view of a portion of a wall of the present invention under construction. The shear-resisting assembly is shown being tilted into the wall.

FIG. 14 is a front, cross-sectional view of a portion of a wall built according to the present invention, showing the upper

3

portion of the shear-resisting assembly. A shim is shown placed between the top plate of the wall and the top strut of the shear-resisting assembly.

FIG. 15 is a graph showing deflection of a shear-resisting assembly at each cycle, according to the procedure used in testing shear-resisting assemblies made according to the present invention.

FIG. 16 is a front view showing a shear assembly made up of a plurality of adjoining structural panels.

DESCRIPTION OF THE PREFERRED EMBODIMENT

The present invention relates to an improved wall 1 designed to resist lateral forces imposed on a building incorporating the wall 1. The building has an underlying structural component 2 that supports the wall 1. As shown in FIG. 9, the underlying structural component 2 can be a cement foundation. Often, the wall 1 will not rest on the foundation directly, but rather on a floor diaphragm resting on the foundation. In this case, the underlying structural component 2 becomes the floor diaphragm and the foundation. When the wall 1 occurs at the second or third level of the building, the underlying structural component 2 is the supporting floor diaphragms, lower levels and the foundation of the building.

The wall 1 is formed with a bottom plate 3 that rests on the underlying structural component 2 of the building. The bottom plate 3 is connected to the underlying structural component 2 by means 4 for connecting the bottom plate 3 to the underlying structural component 2 of the building. A plurality of vertically-disposed studs 5 are disposed on top of the bottom plate 3. These studs 5 are connected to the bottom plate 3 by means 6 for connecting the plurality of vertically-disposed studs 5 to the bottom plate 3. A top plate 7 is supported by and rests on the vertically-disposed studs 5. The top plate 7 is connected to the vertically-disposed studs 5 by means 8 for connecting the top plate 7 to the vertically-disposed studs 5.

The wall 1, itself, incorporates a shear-resisting assembly 9 that is connected to the top plate 7 of the wall 1 and is also connected to the underlying structural component 2. These connections allow lateral forces on the top plate 7 of the wall 1 and on the underlying structural component 2 to be transmitted to the shear-resisting assembly 9. The shear-resisting assembly 9 is disposed between the top plate 7 and the underlying structural component 2. The shear-resisting assembly 9 has a planar shear-resisting element 10. The planar shear-resisting element 10, itself, has a proximal face 11, a distal face 12, a top edge 13, a bottom edge 14 and first and second side edges 15 and 16. The shear-resisting assembly 9 includes a top strut 17 connected to the proximal face 11 near the top edge 13 of the shear-resisting element 10. The top strut 17 is disposed substantially parallel to the top plate 7 of the wall 1. The shear-resisting assembly 9 includes a bottom strut 18 connected to the proximal face 11 near the bottom edge 14 of the shear-resisting element 10. A first chord 19 is connected to the proximal face 11 near the first side edge 15 of the shear-resisting element 10. A second chord 20 is also connected to the proximal face 11 near the second side edge 16 of the shear-resisting element 10. The top and bottom struts 17 and 18 and the first and second chords 19 and 20 are connected to the shear-resisting element 10 by means 21 for connecting the top strut 17, the bottom strut 18, the first chord 19 and the second chord 20 to the shear-resisting element 10. The top and bottom struts 17 and 18 and the first and second chords 19 and 20 form a supporting frame for the shear-resisting element 10.

4

The shear-resisting assembly 9 is connected to the top plate 7 of the wall 1 by means 22 for connecting the shear-resisting assembly 9 to the top plate 7 and is connected to the underlying structural component 2 of the building by means 23 for connecting the shear-resisting assembly 9 to the underlying structural component 2.

In the preferred form of the invention, the bottom plate 3 of the wall 1, the plurality of vertically-disposed studs 5 resting on the bottom plate 3, the top plate 7 of the wall 1, the shear-resisting element 10 of the shear-resisting assembly 9, the top and bottom struts 17 and 18 of the shear-resisting assembly 9, and the first and second chords 19 and 20 of the shear-resisting assembly 9 are all made of wood or wood composites. These members can also be made of steel or synthetic building materials.

As shown in FIG. 9, in the preferred form of the invention, when the underlying structural component 2 is the foundation of the building, the means 4 for connecting the bottom plate 3 to the underlying structural component 2 of the building are foundation anchors in the shape of bolts bent to form a mechanical interlock with the foundation. The inventor has found $\frac{3}{8}$ " diameter ASTM A307 or A36 foundation anchors embedded to a proper depth to be sufficient for most foundations. The length of the foundation anchors, the spacing between foundation anchors and placement of the foundation anchors in the foundation are determined according to the forces that are imposed on the wall 1 and the strength of the foundation. The means 4 for connecting the bottom plate 3 to the underlying structural component 2 of the building can also be strap anchors, mudsill anchors, bolts, retrofit bolts, foundation plate holdowns, straps, ties or a combination thereof. When the underlying structural component 2 consists of a floor diaphragm and the foundation of the building, the means 4 for connecting the bottom plate 3 to the underlying structural component 2 of the building can be nails, screws, bolts, retrofit bolts, framing anchors, angles, ties, plates, straps or a combination thereof. When the underlying structural component 2 consists of a floor diaphragm, a supporting wall and the foundation, the means 4 for connecting the bottom plate 3 to the underlying structural component 2 of the building can be nails, screws, bolts, foundation bolts, retrofit bolts, framing anchors, angles, ties, plates, straps or a combination thereof. When the underlying structural component 2 consists of a plurality of floor diaphragms, a plurality of supporting walls and the foundation, the means 4 for connecting the bottom plate 3 to the underlying structural component 2 of the building can be nails, screws, bolts, retrofit bolts, framing anchors, angles, ties, plates, straps or a combination thereof.

As shown in FIG. 10, the preferred means 6 for connecting the plurality of vertically-disposed studs 5 to the bottom plate 3 are zinc-coated nails, but screws, adhesives, welds, clips, angles, framing anchors, stud-plate ties, ties, straps or a combination thereof can also be used.

As shown in FIG. 10, the preferred means 8 for connecting the top plate 7 to the vertically-disposed studs 5 are also zinc-coated nails, but screws, adhesives, welds, clips, angles, framing anchors, stud-plate ties, ties, straps or a combination thereof can also be used.

As shown in FIG. 1, the preferred means 21 for connecting the top strut 17, the bottom strut 18, the first chord 19 and the second chord 20 to the shear-resisting element 10 are 10d common 0.148"x3" nails, but screws, welds, clips, ties, brackets, angles staples, adhesives or a combination thereof can also be used. As shown in FIG. 1, nails should usually be spaced 2" apart around the shear-resisting element 10 near the top and bottom edges 13 and 14 and the first and second side

edges **15** and **16** to achieve maximum shear resistance without causing splitting of the shear-resisting element **10**.

As shown in FIG. **10**, the preferred means **22** for connecting the shear-resisting assembly **9** to the top plate **7** of the wall **1** are top plate fasteners having a threaded shank portion, but nails, welds, bolts, straps, brackets, ties, angles, anchor plates, clips, framing anchors or a combination thereof can also be used. The preferred top plate fasteners are $\frac{1}{4}$ " \times "**6**" Simpson Strong Drive Screws. The top plate fasteners are inserted through the top strut **17** of the shear-resisting assembly **9** and into the top plate **7** of the wall **1**. The number of top plate fasteners is dependent on the lateral loads the shear-resisting assembly **9** is expected to carry and the strength of the top plate fasteners.

As shown in FIG. **10**, the preferred means **23** for connecting the shear-resisting assembly **9** to the underlying structural component **2** of the building is a foundation anchor just like the means **4** for connecting the bottom plate **3** of the wall **1** to the underlying structural component **2**. The inventor has found three $\frac{5}{8}$ " diameter ASTM A307 or A36 foundation anchors embedded to a proper depth to be sufficient for anchoring a four foot wide shear-resisting assembly to most foundations. The length of the foundation anchors, the spacing between foundation anchors and placement of the foundation anchors in the foundation are determined according to the forces that are imposed on the shear-resisting assembly **9** and the strength of the foundation. The means **23** for connecting the shear-resisting assembly **9** to the underlying structural component **2** of the building can also be strap anchors, mud-sill anchors, bolts, retrofit bolts, foundation plate holdowns, straps, of ties or a combination thereof. When the underlying structural component **2** consists of a floor diaphragm and the foundation of the building, the means for connecting the shear-resisting assembly **9** to the underlying structural component **2** of the building can be nails, screws, bolts, retrofit bolts, framing anchors, angles, ties, plates, straps or a combination thereof. When the underlying structural component **2** consists of a floor diaphragm, a supporting wall, and the foundation, the means **23** for connecting the shear-resisting assembly **9** to the underlying structural component **2** of the building can be nails, screws, bolts, retrofit bolts, framing anchors, angles, ties, plates, straps or a combination thereof. When the underlying structural component **2** consists of a plurality of floor diaphragms, a plurality of supporting walls, and the foundation, the means **23** for connecting the shear-resisting assembly **9** to the underlying structural component **2** of the building can be nails, screws, bolts, retrofit bolts, framing anchors, angles, ties, plates, straps or a combination thereof.

As shown in FIG. **10**, in the preferred form of the invention the shear-resisting assembly **9** rests directly on the underlying structural component **2**, bypassing the bottom plate **3** of the wall **1**.

As also shown in FIG. **10**, in the preferred form the first and second chords **19** and **20** of the shear-resisting assembly **9** rest directly on the underlying structural component **2**. This prevents the bottom strut **18** from being crushed when moment reactions exert compressive forces on the first and second chords **19** and **20**. Because the first and second chords **19** and **20** rest directly on the underlying structural component **2**, **20** gauge steel standoff plates **51** are preferably attached to the bottoms of the first and second chords **19** and **20** to serve as a moisture barrier. See FIGS. **6**, **7A** and **7B**. This is accomplished with two 8d nails, end-nailed through the standoff plates **51**.

As shown in FIG. **7A**, in the preferred form the means **23** for connecting the shear-resisting assembly **9** to the underly-

ing structural component **2** is a foundation anchor anchored to the underlying structural component **2**. The foundation anchor is designed to transmit lateral forces imposed on the underlying structural component **2** to the shear-resisting assembly **9**.

As shown in FIG. **7A**, the bottom strut **18** is formed with an opening through which the foundation anchor passes. Preferably, the opening in the bottom strut **18** is oversized to accommodate mis-installation of the foundation anchor in the underlying structural component **2**. As is shown in FIG. **7A**, the opening in the bottom strut **18** is preferably a slotted opening **25**, the slotted opening **25** being oriented so that the bottom strut **18** can slide horizontally and at right angles to the length of the wall **1**. As is shown in FIG. **11**, the opening in the bottom strut **18** can also be a notch **26** in the bottom strut **18** that allows the bottom strut **18** to slide into place. A washer **50** and a nut **30** can be added to improve the connection and provide resistance to uplift forces on the shear-resisting assembly **9**.

As shown in FIG. **7A**, epoxy **27** can be inserted within the opening in the bottom strut **18** to ensure close contact between the foundation anchor and the bottom strut **18**.

As shown in FIG. **7B**, in the preferred form of the present invention a toothed plate **28**, having teeth **29**, is used to eliminate play between the bottom strut **18** and the foundation anchor due to the oversized opening in the bottom strut **18** that receives the foundation anchor. The toothed plate **28** receives the foundation anchor and connects to the bottom strut **18** with the teeth **29**. A nut **30** is fitted onto the foundation anchor and tightened down, forcing the teeth **29** of the toothed plate **28** into the bottom strut **18**. A washer **50** can be added to improve the connection.

As shown in FIG. **10**, in the preferred form the shear-resisting assembly **9** also has first and second anchor bolts **31** that are anchored to the underlying structural component **2** and are disposed near the first and second chords **19** and **20**. The first and second anchor bolts **31** are received by first and second holdowns **32**. Nuts **33**, fitted onto the first and second anchor bolts **31**, engage the first and second holdowns **32**. The first and second holdowns **32** are connected to the first and second chords **19** and **20** by means **34** for connecting the first and second holdowns **32** to the first and second chords **19** and **20**.

The first and second anchor bolts **31** should at least be $\frac{7}{8}$ " diameter ASTM A307 or A36 anchor bolts **31** embedded in the foundation at proper locations and a selected depth to ensure sufficient resistance to the loads the shear-resisting assembly **9** is designed to carry.

As shown in FIG. **7A**, the bottom strut **18** is preferably formed with anchor bolt openings through which the first and second anchor bolts **31** pass. Preferably, the anchor bolt openings in the bottom strut **18** are oversized to accommodate mis-installation of the anchor bolts **31** in the underlying structural component **2**. The anchor bolt openings in the bottom strut **18** are also preferably slotted openings **36**, the slotted openings **36** being oriented so that the bottom strut **18** can slide horizontally and at right angles to the length of the wall **1**.

As shown in FIG. **7A**, the first and second holdowns **32** are preferably formed with slotted openings **38** that are oriented in the same direction as, and are in general alignment with, the slotted openings **25** in the bottom strut **18** when the first and second holdowns **32** are attached to the first and second chords **19** and **20**, the slotted openings **38** receiving the first and second anchor bolts **31**.

As shown in FIG. **11**, the anchor bolt openings in the bottom strut can also be formed as notches **37** in the bottom

7

strut **18** that allow the bottom strut **18** to slide into place. When the anchor bolt openings in the bottom strut **18** are formed as notches **26** and **37**, portals **39** should be formed in the first and second holdowns **32** that allow the shear-resisting assembly **9** to slide into place.

As shown in FIG. **10**, the means **34** for connecting the first and second holdowns **32** to the first and second chords **19** and **20** are holdown fasteners having threaded shank portions. Preferably, these holdown fasteners are $\frac{1}{4}$ " \times "3" Simpson Strong Drive screws, although they can also be bolts, nails, screws or adhesives.

As shown in FIG. **10B**, holdown fasteners are preferably inserted only a selected distance into the first and second chords **19** and **20** without passing all the way through the first and second chords **19** and **20**. This allows the shear-resisting assembly **9** to fit closely between the studs **5** of the wall **1**.

As shown in FIGS. **4** and **5**, the means **21** for connecting the top strut **17**, the bottom strut **18**, the first chord **19** and the second chord **20** to the shear-resisting element **10** are preferably edge fasteners having shank portions **41**. Preferably, these edge fasteners are 10d common 0.148" \times "3" nails. Preferably, the first and second chords **19** and **20** and the top strut **17** are attached to the shear-resisting element **10** by two rows of nails. The rows of nails are spaced $\frac{1}{2}$ " apart. Within the rows, the nails are spaced 4" apart. As is best shown in FIG. **8**, the nails between rows are staggered approximately 2" apart. Preferably, the bottom strut **18** is attached to the shear-resisting element **10** by three rows of nails. The rows of nails are spaced $\frac{1}{2}$ " apart. Within the rows, the nails are spaced 4" apart. Between rows, the nails are staggered approximately 1.3" apart. Nails should be spaced at least 0.357" from the top and bottom edges **13** and **14** and the first and second side edges **15** and **16** of the shear-resisting element **10** to reduce splitting.

As best shown in FIGS. **3**, **4** and **5**, in the preferred form of the shear-resisting assembly **9**, what the inventors call boundary edging members **42** are used to strengthen the connection between the shear-resisting element **10** and the top and bottom struts **17** and **18** and the first and second chords **19** and **20**. The boundary edging members **42** are disposed on the shear-resisting element **10** at the top and bottom edges **13** and **14** and the first and second side edges **15** and **16**. The boundary edging members **42** are pierced by the shank portions **41** of the edge fasteners.

Preferably, the boundary edging members are u-shaped channels, having a pair of legs **43** joined by a central member **44**, that embrace the shear-resisting element **10**. The shank portion **41** of each of the edge fasteners passes through the legs **43** of the u-shaped channels. The boundary edging members **42** are preferably formed from galvanized 20 gauge sheet metal. The legs **43** and central member **44** of the boundary edging members **42** can be of varying widths to accommodate various nailing configurations and shear-resisting elements **10** of varying thickness. Preferably, 0.125" diameter holes **52**, spaced 1" apart are formed in the central member **44**. These holes **52** allow moisture to escape from the top and bottom edges **13** and **14** and first and second side edges **15** and **16** of the shear-resisting element **10**.

When the shear-resisting assembly **9** is sufficiently wide, the shear-resisting assembly **9** is preferably made with intermediate studs **45** disposed between the top and bottom struts **17** and **18** of the shear-resisting element **10**. These intermediate studs **45** are preferably formed from 1.5" \times "3" machine stress rated (MSR) Southern Yellow Pine studs. These intermediate studs **45** are connected to the top and bottom struts **17** and **18** by means **46** for connecting the intermediate studs **45** to the top and bottom struts **17** and **18**. Preferably, the means

8

46 for connecting the intermediate studs **45** to the top and bottom struts **17** and **18** are 20d 0.150" \times "5.5" nails. Also, in the preferred embodiment the intermediate studs **45** of the shear-resisting assembly **9** are connected to the shear-resisting element **10** by means **47** for connecting the intermediate studs **45** to the shear-resisting element **10**. As best shown in FIG. **1**, in the preferred form the means **47** for connecting the intermediate studs **48** to the shear-resisting element **10** are 10d common 0.148" \times "3" nails spaced 12" apart.

As shown in FIGS. **4** and **5**, in the preferred embodiment the first and second chords **19** and **20** of the shear-resisting assembly **9** are formed from two elongated wood members **48**, laminated together. Preferably, these elongated wood members **48** are dried 1.5" \times "3.5" MSR Southern Yellow Pine. The wood members **48** are glued together and then trimmed to a dimension of 2.875" \times "3". Preferably, the top strut **17** is formed from this same material and in the same manner from two elongated wood members **53** laminated together. The bottom strut **18** is preferably 2.5" \times "3" pressure-treated Southern Yellow Pine. At these dimensions, the shear-resisting element **10** can be $\frac{1}{32}$ " wide and still fit within the profile of a wall **1** formed from 2 \times 4 members. The shear-resisting assembly **9** is designed to fit within a wall **1** without interfering with the construction of the wall **1**. Electrical and plumbing conduits can easily be run through the wooden first and second chords **19** and **20**, and paneling and sheet-rocking can be carried out without interference from the shear-resisting assembly **9**.

The shear-resisting assembly **9** can be formed in a variety of dimensions to fit various spaces. In some instances, the shear-resisting element **10** will comprise a single structural panel **49**. See FIG. **1**. In other instances, the shear-resisting element **10** will be so large that the shear-resisting element **10** will need to be formed from a plurality of adjoining structural panels disposed in a single plane, forming joints between the structural panels. Structural panels **49** are preferably Oriented Strand Board (OSB) $\frac{1}{2}$ " APA Rated Structural 1 Sheathing, $\frac{3}{16}$, Exposure 1. The structural panels **49** can also be formed from plywood, wood and synthetic laminates, wood and steel laminates, gypsum and steel laminates, synthetic materials and steel.

When the shear-resisting element **10** is constructed from a plurality of structural panels **49**, intermediate studs **45** and means **46** for connecting the intermediate studs **45** to the shear-resisting element **10** can be used to join the structural panels **49** together at their joints. Preferably, the means **46** for connecting the intermediate studs **45** to the shear-resisting element **10** are 10d common 0.148" \times "3" nails.

Preferably, the bottom strut **18** is made from pressure-treated Southern Yellow Pine, having a cross-sectional dimensions of 2.5" \times "3". The bottom strut **18** can also be constructed in the same manner and from the same materials as the first and second chords **19** and **20** with the added step of pressure-treating the materials to protect against moisture intrusion.

As shown in FIG. **10**, the top plate **7** is preferably made from a plurality of individual elongated wood members **54** joined together by nails or screws to form a double layer.

As described below, in the preferred method of building the wall **1** of the present invention, the shear-resisting assembly **9** is installed first and the remaining components of the wall **1** are built around it. However, sometimes the shear-resisting assembly **9** will need to be added after the remaining components of the wall **1** have been constructed and installed on the underlying structural component **2**. In these instances, the shear-resisting assembly **9** can be slid into place if the bottom strut **18** is formed with notches **26** for the foundation anchors,

notches 37 for the anchor bolts and the first and second holdowns 32 are formed with portals 39. See FIG. 11. The shear-resisting assembly 9 could also be tilted into place as is shown in FIGS. 12 and 13. When the shear-resisting assembly 9 is tilted into place, it is best to provide a shim 55 between the top plate 7 of the wall 1 and the top strut 17 of the shear-resisting assembly 9 to eliminate any space between the two.

As shown in FIG. 1, additional nails 56 can be used to connect the top strut 17 of the shear-resisting assembly 9 to the first and second chords 19 and 20.

The following is a description of how to make the preferred form of the present invention, where the underlying structural component 2 is a concrete foundation, as best shown in FIG. 10.

First the shear-resisting assembly 9 is constructed. Preferably, this is done at a factory by assemblers who specialize in their construction. Slotted openings 25 and slotted anchor bolt openings 36 are formed in the bottom strut. The top and bottom struts 17 and 18, the first and second chords 19 and 20 and the intermediate studs 45 are cut to the desired size. The first and second holdowns 32 are attached to the first and second chords 19 and 20. The top strut 17, bottom strut 18, the first chord 19, the second chord 20 and the intermediate studs 45 are placed on a jig. The intermediate studs 45 are connected to the top and bottom struts 17 and 18 with nails driven through the top and bottom struts 17 and 18. Then the first and second chords 19 and 20 are attached to the top strut 17 with nails also driven through the top strut 17, forming a frame for the shear-resisting element. Then a shear-resisting element 10, fitted with boundary edging members 42, is placed on top of the frame. The edge fasteners are then driven through the boundary edging members 42 and shear-resisting element 10 and into the frame. The intermediate studs 45 are also attached to the frame by nails, completing the construction of the shear-resisting assembly 9 at the factory.

At the construction site, the foundation anchors for anchoring the bottom plate 3 of the wall 1, the foundation anchors for anchoring the bottom strut 18 of the shear-resisting assembly 9, and the anchor bolts 31 for anchoring the first and second chords 19 and 20 of the shear-resisting assembly 9 are set into the form for the concrete foundation at the predetermined locations. The concrete form is then poured and allowed to cure.

Next, the shear-resisting assembly 9 is installed on the foundation anchors and the anchor bolts. The foundation anchors are inserted into the slotted openings 25, and the anchor bolts 31 are inserted into the slotted anchor bolt openings 36 in the bottom strut 18 and the slotted openings 38 in the holdowns 32. The toothed plates 28, washers 50 and nuts 30 are then fitted on the foundation anchors. When the shear-resisting assembly 9 is properly aligned with the foundation, the nuts 30 are tightened down on the foundation anchors and the shear-resisting assembly 9 is locked in place. The nuts 33 for the anchor bolts 31 are then tightened down so that they bear upon the first and second holdowns 32.

Next, the remaining wall 1 is constructed. First, the bottom plate 3 is prepared for fitting over the foundation anchors that will attach it to the foundation. This is done by drilling holes in the bottom plate 3 at selected points. Next, the studs 5 are attached to the top and bottom plates 7 and 3. Generally, this will be accomplished with the wall 1 lying flat on the ground. When this stage is completed, the wall 1 is tilted up and fitted over the foundation anchors. Finally, the shear-resisting assembly 9 is attached to the wall 1 by top plate fasteners. The number of top plate fasteners used is dependent on the strength of the top plate fasteners and the loads they will be designed to carry.

Testing

In order to characterize and to determine the preferred form of the present invention, individual shear-resisting assemblies were constructed and tested.

The shear-resisting assemblies were tested in Brea, Calif. at the Simpson Strong-Tie Co. Laboratory on a machine designed to simulate their behavior when inserted in a wall during the cyclic (reversing) lateral forces that would occur during an earthquake.

The tests determine the strength and stiffness of the shear-resisting assemblies. Stiffness is measured in terms of the force that is required to displace the top strut a given lateral distance. Strength is described in these terms as well. Strength is also described by what level of displacement force was being exerted on shear-resisting assembly when there was complete failure—the point at which the shear-resisting assembly no longer provided any meaningful resistance to lateral forces.

Test results are reported in Tables 1, 2 and 3 for a number of different shear-resisting assemblies. Results are reported in terms of the force required to displace the top of the shear-resisting assembly 0.5" (Load at 0.5") under cyclic loading conditions and 1.0" (Load at 1.0") under cyclic loading conditions. Also reported is the load at which complete failure occurred (Maximum Load).

The tests were conducted according to a protocol developed by the Joint Technical Coordinating Committee on Masonry Research (TCCMAR) in 1987. See Porter, M. L., *Sequential Phased Displacement (SPD) procedure for TCCMAR Testing*, Proceedings of the Third Meeting of the Joint Technical Coordinating Committee on Masonry Research, US-Japan Coordinated Earthquake Research Program, Tomamu, Japan.

The TCCMAR procedure hinges on the concept of the First Major Event (FME), which is defined as the first significant limit state which occurs during the test. The FME occurs when the load capacity of the wall, upon recycling of load to the same wall displacement increment, first drops noticeably from the original load and displacement. FME for all tests was assumed to occur when an 8 foot high shearwall can be displaced 0.8 inches at its top.

The TCCMAR procedure consists of applying cycles of fully-reversing displacement to the shearwall at various increments of the wall's assumed FME. See FIG. 15.

In the first phase, three cycles of fully-reversing displacement are applied to the top of the shearwall at 25% of FME. The first phase continues by then applying three cycles of fully-reversing displacement at 50% of FME. Then, three cycles of fully-reversing displacement are applied at 75% of FME. Then, the fully-reversing displacement is increased for one cycle to 100% of FME. This is the maximum displacement for this first phase. Next, "decay" cycles of displacement for one cycle each at 75%, 50%, and 25% of the phase-maximum are applied in that order respectively. Then, three stabilizing cycles of displacement at the phase-maximum (100% of FME) are applied to the top of the shearwall. These phase-ending cycles stabilize the load-displacement response of the shearwall, prior to the next phase of testing.

In the second phase, which follows immediately according to the test frequency, one phase-maximum cycle of fully-reversing displacement is applied at 125% of FME. Next, "decay" cycles of displacement for one cycle each at 75%, 50%, and 25% of the maximum for that phase are applied in that order respectively. Then, three stabilizing cycles of displacement equal to the phase-maximum for the phase (125% of FME for the second phase) are applied to the shearwall.

11

In the third phase, one phase-maximum cycle of fully-reversing displacement at 150% of FME is applied to the shearwall. Next, "decay" cycles of displacement for one cycle each at 75%, 50% and 25% of the phase-maximum for the phase are applied. Then, three stabilizing cycles of displacement equal to the phase-maximum (150% of FME for the third phase) are applied to the top of the shearwall.

Successive phases are continued in a like manner as the second and third phases at increased increments, as shown in FIG. 15. The incremental cyclic load-displacement phases are continued at phase-maximums of 175%, 200%, 250%, 300%, 350% and 400% of FME, or until the wall exhibits excessive displacement, or until the wall displacement exceeds the capacity of the test equipment, which in this case was ± 3.0 inches. In all trials, the lateral load capacity of the shearwall had greatly diminished by the time the shearwall was displaced 3.0 inches.

Racking shear loads were applied to the test specimens through an actuator located at the top of the wall. The actuator was placed so that the actuator did not interfere with any movement of the structural panel. The actuator that caused deflection at the top of the shearwall was computer controlled. Actuator loads were applied to the wall at a frequency of one cycle per second.

The shear-resisting assemblies were attached to the base of the test frame with $\frac{5}{8}$ " diameter foundation bolts, passing through the bottom strut, spaced approximately 12 inches on center, and approximately 12 inches from the ends of the shearwall.

The vertically-disposed first and second chords, of the shear-resisting assembly test specimens were attached to the test frame with holdowns and $\frac{7}{8}$ " inch anchor bolts that passed through the bottom strut. All tests were conducted with Simpson Strong-Tie PHD8 holdowns, except test F945 which used an experimental holdown formed in accordance with the present invention. The holdowns used for Test F945 are formed with slotted openings for receiving the first and second anchor bolts and attach to the first and second chords by means of $\frac{1}{4}$ " \times 3" Simpson Strong Drive Screws. The PHD8 holdowns also attach to the first and second chords by means of $\frac{1}{4}$ " \times 3" Simpson Strong Drive Screws, except they are not formed with slotted openings for receiving the first and second anchor bolts.

Lumber used for the tests varied according to the goals of the test. Generally, lumber moisture content at the time of the tests was approximately 20 to 25%.

The top struts were generally doubled 2 \times 4s connected with nails. The top struts for each shear wall were 48" long. The bottom struts were also typically 2 \times 4s. In addition to the top and bottom struts and the first and second chords, two intermediate 2 \times 4 studs, spaced 16" on center from each other and the first and second chords, were added and end-nailed to the

12

top and bottom struts with nails according to currently accepted building practices, for most tests.

A variety of chords were used for the vertically-disposed first and second chords. In all tests, except test F498, which reflects current building practices, the first and second chords were approximately 93" tall. This means the chords sat directly on the test frame. Setting the chords on the test frame eliminates failure of the shear-resisting assembly due to crushing of the bottom strut by the chords, and greatly improves the performance of the shear-resisting assembly. This particular design of using long chords that bypass the bottom strut is especially effective where the shear-resisting assembly sits on the relatively non-compressible building foundation.

Plywood and Oriented Strand Board structural panels were used for the structural panel or shear-resisting element in the tests. All tests were conducted with one 4' \times 8' structural panel applied to the framing members with the face grain or strength axis disposed vertically.

Generally, the structural panels were fastened to the top and bottom struts and the first and second chords by steel 10d common nails that were either 2.125" long or 3" long. All nails were driven into the framing members to a depth of at least 11 times their shank diameter to comply with the Uniform Building Code. All nails were driven so that the head of the nail sat flush against either the shear-resisting assembly or the boundary edging members. All nails were spaced 2" on center around the periphery of the structural panel, except where noted otherwise in the tables. Generally, the structural panel was attached to the intermediate studs with 10d \times 3" long common nails spaced 12" on center.

Table 1 represents a progression from a basic shear-resisting assembly built according to the present invention (Test 495) to a shear-resisting assembly that incorporates most of the preferred elements of the present invention (Test 945). Test F945 used the nailing patterns described in the description of the preferred embodiment to connect the shear-resisting element to the first and second chords and to the bottom and top struts. Test F945 also used the preferred material of Oriented Strand Board for the structural panel. As in the preferred embodiment, the chords of Test F945 were long chords. In Test F945, the first and second chords bypassed the bottom strut and rested directly on the test frame. Test F945 also used first and second chords made from individual wood members glued together to form a laminate. Test F945 used "u" shaped boundary edging members. Finally, Test F945 used holdowns having a slotted openings that connected to the first and second chords by means of holdown fasteners having threaded shanks.

Tables 2 and 3 provide as direct a comparison as is possible between shear-resisting assemblies using different materials for the first and second chords. Again, Test F945 is the preferred unit among the compared assemblies.

TABLE 1

Test:	F498	F495	F494	F945
Date:	2/7/97	2/5/97	2/3/97	10/6/97
Wall size:	4' \times 8'	4' \times 8'	4' \times 8'	4' \times 8'
Nailing schedule:	2" o.c.	2" o.c.	2" o.c.	2" o.c. along top and sides; 3 rows staggered at 4" o.c. along bottom
Nails:	10d nails	10d nails	10d nails	10d common x 3" nails
Structural panel:	1/2" S-1 plywood	1/2" S-1 plywood	1/2" S-1 plywood	15/32" S-1 Potlatch OSB

TABLE 1-continued

Chord design:	short	long	long	long
Chords:	4' x 4' post	4' x 4' post	4' x 4' post	Wilamette B4 Glu-Lam SYP
Bottom strut:	1-Wolmerized 2 x 4	1-Wolmerized 2 x 4	1-Wolmerized 2 x 4	1-Douglas Fir 3 x 4
Boundary edging present:	no	no	"u" shaped 20 gauge edging	"u" shaped 20 gauge edging
Holddown:	PHD8	PHD8	PHD8	New holddown
Foundation Bolts:	3-5/8" bolts	3-5/8" bolts	3-5/8" bolts	3-5/8" bolts
Load at 0.5"	4,200	4,400	5,250	4,900
Load at 1.0"	6,350	6,450	8,650	9,000
Maximum Load	8,400	8,250	11,850	13,150

TABLE 2

Test:	F537	F900	F530	F945
Date:	3/7/97	6/16/97	3/3/97	10/6/97
Wall size:	4' x 8'	4' x 8'	4' x 8'	4' x 8'
Nailing schedule:	2" o.c.	2" o.c.	2" o.c.	2" o.c. along top and sides; 3 rows staggered at 4" o.c. along bottom
Nails:	10d common x 3" nails	10d x 3" nails	10d x 3" nails	10d common x 3" nails
Structural panel:	1/2" S-1 plywood	15/32 S-1	1/2 S-1 plywood	15/32 S-1 Potlatch OSB
Chord design:	long	long	long	long
Chords:	4 x 4 Douglas Fir post	4 x 4 Southern Yellow Pine post	4 x 4 square Paralam post	Wilamette B4 Glu-Lam SYP
Bottom strut:	1-Wolmerized 2' x 4'	1-Wolmerized 2' x 4'	1-Wolmerized 2' x 4'	1-Douglas Fir 3 x 4
Test:	F537	F900	F530	F945
Boundary edging present:	two 20 gauge straps	"u" shaped 20 gauge edging	"u" shaped 20 gauge edging	"u" shaped 20 gauge edging
Holddown:	PHD8	PHD8	PHD8	New holddown
Foundation Bolts:	3-5/8" bolts	3-5/8" bolts	3-5/8" bolts	3-5/8" bolts
Load at 0.5"	4,850	5,100	5,100	4,900
Load at 1.0"	7,500	8,150	8,000	9,000
Maximum Load	10,550	11,300	11,000	13,150

TABLE 3

Test:	F496	F536	F910	F945
Date:	2/5/97	3/6/97	7/8/97	10/6/97
Wall size:	4' x 8'	4' x 8'	4' x 8'	4' x 8'
Nailing schedule:	2" o.c.	2" o.c.	2" o.c.	2" o.c. along top and sides; 3 rows staggered at 4" o.c. along bottom
Nails:	10d	10d x 3" nails	10d x 3" nails	10d common x 3" nails
Structural panel:	1/2" S-1 plywood	1/2" S-1 plywood	15/32" S-1 Potlatch OSB	15/32" S-1 Potlatch OSB
Chord design:	long	long	long	long
Chords:	3' x 3.5' Timberstrand post	2-1.75" Microlam Studs glued together	Wilamette B4 Glu-Lam SYP	Wilamette B4 Glu-Lam SYP
Bottom strut:	1-Wolmerized 2' x 4'	1-Wolmerized 2' x 4'	1-Wolmerized 2' x 4'	1-Douglas Fir 3 x 4
Boundary edging present:	"u" shaped 20 gauge edging	"u" shaped 20 gauge edging	"u" shaped 20 gauge edging	"u" shaped 20 gauge edging
Holddown:	PHD8	PHD8	PHD8	New holddown
Foundation Bolts:	3-5/8" bolts	3-5/8" bolts	3-5/8" bolts	3-5/8" bolts
Load at 0.5"	4,750	4,200	5,500	4,900
Load at 1.0"	7,050	7,150	8,650	9,000
Maximum Load	9,000	10,450	11,500	13,150

15

We claim:

1. A wall designed to resist lateral forces imposed on a building incorporating said wall, said building having an underlying structural component supporting said wall, said wall comprising:
 - a. a bottom plate resting on said underlying structural component of said building;
 - b. a foundation anchor for connecting said bottom plate to said underlying structural component of said building;
 - c. a plurality of vertically-disposed studs resting on said bottom plate;
 - d. nails for connecting said plurality of vertically-disposed studs resting on said bottom plate;
 - e. a top plate resting on said vertically-disposed studs;
 - f. nails for connecting said top plate to said vertically-disposed studs;
 - g. a shear-resisting assembly connected to said top plate and also connected to said underlying structural component and disposed between said top plate and said underlying structural component, said shear-resisting assembly including,
 1. a planar shear-resisting element made from wood, said planar shear-resisting element having a proximal face and a distal face, a top edge, a bottom edge and first and second side edges, said shear-resisting assembly also including,
 2. a wood top strut connected to said proximal face near said top edge of said shear-resisting element, and disposed substantially parallel to said top plate of said wall,
 3. a wood bottom strut connected to said proximal face near said bottom edge of said shear-resisting element,
 4. a wood first chord connected to said proximal face near said first side edge of said shear-resisting element,
 5. a wood second chord connected to said proximal face near said second side edge of said shear-resisting element, and
 6. edge fasteners comprising common nails having a flanged head and shank portions of uniform diameter for connecting said top strut, said bottom strut, said first chord and said second chord to said shear-resisting element, said top and bottom struts and said first and second chords forming a supporting frame for said shear-resisting element, said shank portions of each of said nails being closely received by said shear-resisting element along said portion of said shank embedded in said shear-resisting element and one of said first chord, said second chord, said top strut or said bottom strut with said flanged head of said nails disposed adjacent to said distal face of said shear-resisting element;
 7. boundary edging members disposed on said shear-resisting element at said first and second side edges, each of said boundary edging members having an elongated leg that receives a plurality of said edge fasteners, each of said boundary edging members being pierced by said shank portions of said edge fasteners through said elongated leg and thereby strengthening the connection made by said edge fasteners piercing said boundary edging members;
 - h. top plate fasteners, having a threaded shank portion, for connecting said shear-resisting assembly to said top plate of said wall, each said top plate fastener being closely received by both said top plate of said wall and said top strut of said shear resisting assembly; and

16

- i. one or more foundation anchors for connecting said shear-resisting assembly to said underlying structural component of said building.
2. A wall designed to resist lateral forces imposed on a building incorporating said wall, said building having an underlying structural component supporting said wall, said wall comprising:
 - a. a bottom plate resting on said underlying structural component of said building;
 - b. means for connecting said bottom plate to said underlying structural component of said building;
 - c. a plurality of vertically-disposed studs resting on said bottom plate;
 - d. means for connecting said plurality of vertically-disposed studs to said bottom plate;
 - e. a top plate resting on said vertically-disposed studs;
 - f. means for connecting said top plate to said vertically-disposed studs;
 - g. a shear resisting assembly connected to said top plate and also connected to said underlying structural component and disposed between said top plate and said underlying structural component, said shear-resisting assembly including,
 1. a planar shear-resisting element made from wood, said planar shear-resisting element having a proximal face and a distal face, a top edge, a bottom edge and first and second side edges, said shear-resisting assembly also including,
 2. a wood top strut connected to said proximal face near said top edge of said shear-resisting element, and disposed substantially parallel to said top plate of said wall,
 3. a wood bottom strut connected to said proximal face near said bottom edge of said shear-resisting element,
 4. a wood first chord connected to said proximal face near said first side edge of said shear-resisting element,
 5. a wood second chord connected to said proximal face near said second side edge of said shear-resisting element, and
 6. edge fasteners comprising common nails having a flanged head and shank portions of uniform diameter for connecting said top strut, said bottom strut, said first chord and said second chord to said shear-resisting element, said top and bottom struts and said first and second chords forming a supporting frame for said shear-resisting element, said shank portions of each of said nails being closely received by said shear-resisting element along said portion of said shank embedded in said shear-resisting element and one of said first chord, said second chord, said top strut or said bottom strut with said flanged head of said nails disposed adjacent to said distal face of said shear-resisting element;
 7. boundary edging members disposed on said shear-resisting element at said first and second side edges, each of said boundary edging members having an elongated leg that receives a plurality of said edge fasteners, each of said boundary edging members being pierced by said shank portions of said edge fasteners through said elongated leg and thereby strengthening the connection made by said edge fasteners piercing said boundary edging members;
 - h. means for connecting said shear-resisting assembly to said top plate of said wall; and
 - i. a foundation anchor for connecting said shear-resisting assembly to said underlying structural component of

17

said building, said foundation anchor being designed to transmit lateral forces imposed on said underlying structural component to said shear-resisting assembly, and wherein said bottom strut is formed with an opening through which said foundation anchor passes, and said opening in said bottom strut is a notch in said bottom strut that allows said bottom strut to slide into place at a right angle to said planar shear-resisting element.

3. The wall of claim 2, further comprising:

epoxy within said opening in said bottom strut to ensure close contact between said foundation anchor and said bottom strut.

4. A wall designed to resist lateral forces imposed on a building incorporating said wall, said building having an underlying structural component supporting said wall, said wall comprising:

a. a bottom plate resting on said underlying structural component of said building;

b. means for connecting said bottom plate to said underlying structural component of said building;

c. a plurality of vertically-disposed studs resting on said bottom plate;

d. means for connecting said plurality of vertically-disposed studs to said bottom plate;

e. a top plate resting on said vertically-disposed studs;

f. means for connecting said top plate to said vertically-disposed studs;

g. a shear resisting assembly connected to said top plate and also connected to said underlying structural component and disposed between said top plate and said underlying structural component, said shear-resisting assembly including,

1. a planar shear-resisting element made from wood, said planar shear-resisting element having a proximal face and a distal face, a top edge, a bottom edge and first and second side edges, said shear-resisting assembly also including,

2. a wood top strut connected to said proximal face near said top edge of said shear-resisting element, and disposed substantially parallel to said top plate of said wall,

3. a wood bottom strut connected to said proximal face near said bottom edge of said shear-resisting element,

4. a wood first chord connected to said proximal face near said first side edge of said shear-resisting element,

5. a wood second chord connected to said proximal face near said second side edge of said shear-resisting element, and

6. edge fasteners comprising common nails having a flanged head and shank portions of uniform diameter for connecting said top strut, said bottom strut, said first chord and said second chord to said shear-resisting element, said top and bottom struts and said first and second chords forming a supporting frame for said shear-resisting element, said shank portions of each of said nails being closely received by said shear-resisting element along said portion of said shank embedded in said shear-resisting element and one of said first chord, said second chord, said top strut or said bottom strut with said flanged head of said nails disposed adjacent to said distal face of said shear-resisting element;

7. boundary edging members disposed on said shear-resisting element at said first and second side edges, each of said boundary edging members having an elongated leg that receives a plurality of said edge

18

fasteners, each of said boundary edging members being pierced by said shank portions of said edge fasteners through said elongated leg and thereby strengthening the connection made by said edge fasteners piercing said boundary edging members;

h. means for connecting said shear-resisting assembly to said top plate of said wall;

i. means for connecting said shear-resisting assembly to said underlying structural component of said building:

j. first and second anchor bolts that are anchored to said underlying structural component and are disposed near said first and second chords;

k. first and second holdowns that receive said first and second anchor bolts;

l. nuts that are fitted on said first and second anchor bolts and engage said first and second holdowns;

m. means for connecting said first and second holdowns to said first and second chords, and wherein;

n. said bottom strut is formed with anchor bolt openings through which said first and second anchor bolts pass, said anchor bolt openings in said bottom strut being notches in said bottom strut that allow said bottom strut to slide into place at a right angle to said planar shear-resisting element, and are oversized to accommodate mis-installation of said first and second anchor bolts in said underlying structural component.

5. The wall of claim 4, wherein:

a. said first and second holdowns are formed with slotted openings that are oriented in the same direction as, and are in general alignment with, said notches in said bottom strut, when said first and second holdowns are attached to said first and second chords, said slotted openings receiving said first and second anchor bolts; and

b. said first and second holdowns are formed with portals to allow said shear-resisting assembly to be slid into place at a right angle to said planar shear-resisting element.

6. A wall designed to resist lateral forces imposed on a building incorporating said wall, said building having an underlying structural component supporting said wall, said wall comprising:

a. a bottom plate resting on said underlying structural component of said building;

b. means for connecting said bottom plate to said underlying structural component of said building;

c. a plurality of vertically-disposed studs resting on said bottom plate;

d. means for connecting said plurality of vertically-disposed studs to said bottom plate;

e. a top plate resting on said vertically-disposed studs;

f. means for connecting said top plate to said vertically-disposed studs;

g. a shear resisting assembly connected to said top plate and also connected to said underlying structural component and disposed between said top plate and said underlying structural component, said shear-resisting assembly including,

1. a planar shear-resisting element made from wood, said planar shear-resisting element having a proximal face and a distal face, a top edge, a bottom edge and first and second side edges, said shear-resisting assembly also including,

2. a wood top strut connected to said proximal face near said top edge of said shear-resisting element, and disposed substantially parallel to said top plate of said wall,

19

3. a wood bottom strut connected to said proximal face near said bottom edge of said shear-resisting element,
 4. a wood first chord connected to said proximal face near said first side edge of said shear-resisting element,
 5. a wood second chord connected to said proximal face near said second side edge of said shear-resisting element, and
 6. edge fasteners comprising common nails having a flanged head and shank portions of uniform diameter for connecting said top strut, said bottom strut, said first chord and said second chord to said shear-resisting element, said top and bottom struts and said first and second chords forming a supporting frame for said shear-resisting element, said shank portions of each of said nails being closely received by said shear-resisting element along said portion of said shank embedded in said shear-resisting element and one of said first chord, said second chord, said top strut or said bottom strut with said flanged head of said nails disposed adjacent to said distal face of said shear-resisting element;
 7. boundary edging members disposed on said shear-resisting element at said first and second side edges, each of said boundary edging members having an elongated leg that receives a plurality of said edge fasteners, each of said boundary edging members being pierced by said shank portions of said edge fasteners through said elongated leg and thereby strengthening the connection made by said edge fasteners piercing said boundary edging members;
 - h. means for connecting said shear-resisting assembly to said top plate of said wall;
 - i. means for connecting said shear-resisting assembly to said underlying structural component of said building;
 - j. first and second anchor bolts that are anchored to said underlying structural component and are disposed near said first and second chords;
 - k. first and second holdowns that receive said first and second anchor bolts;
 - l. nuts that are fitted on said first and second anchor bolts and engage said first and second holdowns;
 - m. holdown fasteners, having a threaded shank portion and flanged head, for connecting said first and second holdowns to said first and second chords, and wherein;
 - n. said bottom strut is formed with anchor bolt openings through which said first and second anchor bolts pass.
7. The wall of claim 6, wherein, said threaded holdown fasteners are inserted only a selected distance into said first and second chords without passing all the way through said first and second chords and said flanged heads of said holdown fasteners are disposed on inner faces of the first and second chords.
8. A wall designed to resist lateral forces imposed on a building incorporating said wall, said building having an underlying structural component supporting said wall, said wall comprising:
- a. a bottom plate resting on said underlying structural component of said building;
 - b. means for connecting said bottom plate to said underlying structural component of said building;
 - c. a plurality of vertically-disposed studs resting on said bottom plate;
 - d. means for connecting said plurality of vertically-disposed studs to said bottom plate;
 - e. a top plate resting on said vertically-disposed studs;

20

- f. means for connecting said top plate to said vertically-disposed studs;
 - g. a shear resisting assembly connected to said top plate and also connected to said underlying structural component and disposed between said top plate and said underlying structural component, said shear-resisting assembly including,
 1. a planar shear-resisting element made from wood, said planar shear-resisting element having a proximal face and a distal face, a top edge, a bottom edge and first and second side edges, said shear-resisting assembly also including,
 2. a wood top strut connected to said proximal face near said top edge of said shear-resisting element, and disposed substantially parallel to said top plate of said wall,
 3. a wood bottom strut connected to said proximal face near said bottom edge of said shear-resisting element,
 4. a wood first chord connected to said proximal face near said first side edge of said shear-resisting element,
 5. a wood second chord connected to said proximal face near said second side edge of said shear-resisting element, and
 6. edge fasteners consisting of common nails having a flanged head and shank portions of uniform diameter for connecting said top strut, said bottom strut, said first chord and said second chord to said shear-resisting element, said top and bottom struts and said first and second chords forming a supporting frame for said shear-resisting element, said shank portions of each of said nails being closely received by said shear-resisting element along said portion of said shank embedded in said shear-resisting element and one of said first chord, said second chord, said top strut or said bottom strut with said flanged head of said nails disposed adjacent to said distal face of said shear-resisting element;
 - h. means for connecting said shear-resisting assembly to said top plate of said wall;
 - i. means for connecting said shear-resisting assembly to said underlying structural component of said building;
 - j. boundary edging members disposed on said shear-resisting element at said top and bottom edges and said first and second side edges that are pierced by said shank portions of said edge fasteners and thereby strengthen the connection made by said edge fasteners, and wherein said boundary edging members are u-shaped channels, having a pair of legs that receive a plurality of said edge fasteners joined by a central member that embrace said shear-resisting element, each of said edge fasteners passing through each of said legs of said u-shaped channels.
9. A wall designed to resist lateral forces imposed on a building incorporating said wall, said building having an underlying structural component supporting said wall, said wall comprising:
- a. a bottom plate resting on said underlying structural component of said building;
 - b. means for connecting said bottom plate to said underlying structural component of said building;
 - c. a plurality of vertically-disposed studs resting on said bottom plate;
 - d. means for connecting said plurality of vertically-disposed studs to said bottom plate;
 - e. a top plate resting on said vertically-disposed studs;

21

- f. means for connecting said top plate to said vertically-disposed studs;
- g. a shear resisting assembly connected to said top plate and also connected to said underlying structural component and disposed between said top plate and said underlying structural component, said shear-resisting assembly including,
1. a planar shear-resisting element made from wood, said planar shear-resisting element having a proximal face and a distal face, a top edge, a bottom edge and first and second side edges, said shear-resisting assembly also including,
 2. a wood top strut connected to said proximal face near said top edge of said shear-resisting element, and disposed substantially parallel to said top plate of said wall,
 3. a wood bottom strut connected to said proximal face near said bottom edge of said shear-resisting element,
 4. a wood first chord connected to said proximal face near said first side edge of said shear-resisting element,
 5. a wood second chord connected to said proximal face near said second side edge of said shear-resisting element, each of said first and second chords of said shear-resisting assembly being formed from two elongated wood members, laminated together, and
 6. edge fasteners comprising common nails having a flanged head and shank portions of uniform diameter for connecting said top strut, said bottom strut, said first chord and said second chord to said shear-resisting element, said top and bottom struts and said first and second chords forming a supporting frame for said shear-resisting element, said shank portions of each of said nails being closely received by said shear-resisting element along said portion of said shank embedded in said shear-resisting element and one of said first chord, said second chord, said top strut or said bottom strut with said flanged head of said nails disposed adjacent to said distal face of said shear-resisting element;
 7. boundary edging members disposed on said shear-resisting element at said first and second side edges, each of said boundary edging members having an elongated leg that receives a plurality of said edge fasteners, each of said boundary edging members being pierced by said shank portions of said edge fasteners through said elongated leg and thereby strengthening the connection made by said edge fasteners piercing said boundary edging members, said elongated leg of the boundary edging member being disposed on said distal face of said planar shear-resisting element and said flanged head of said nail contacts said elongated leg of said boundary edging member;
- h. means for connecting said shear-resisting assembly to said top plate of said wall;
- i. means for connecting said shear-resisting assembly to said underlying structural component of said building.
- 10.** A wall designed to resist lateral forces imposed on a building incorporating said wall, said building having an underlying structural component supporting said wall, said wall comprising:
- a. a bottom plate resting on said underlying structural component of said building;
 - b. a plurality of vertically-disposed studs resting on said bottom plate;

22

- c. means for connecting said plurality of vertically-disposed studs to said bottom plate;
- d. a top plate resting on said vertically-disposed studs;
- e. means for connecting said top plate to said vertically-disposed studs;
- f. a shear resisting assembly connected to said top plate and also connected to said underlying structural component and disposed between said top plate and said underlying structural component, said shear-resisting assembly including,
1. a planar shear-resisting element made from wood, said planar shear-resisting element having a proximal face and a distal face, a top edge, a bottom edge and first and second side edges, said shear resisting element comprising a plurality of adjoining structural panels disposed in a single plane, forming joints between said structural panels, said shear-resisting assembly also including,
 2. a wood top strut connected to said proximal face near said top edge of said shear-resisting element, and disposed substantially parallel to said top plate of said wall,
 3. a wood bottom strut connected to said proximal face near said bottom edge of said shear-resisting element,
 4. a wood first chord connected to said proximal face near said first side edge of said shear-resisting element,
 5. a wood second chord connected to said proximal face near said second side edge of said shear-resisting element, laminated together, and
 6. edge fasteners comprising common nails having a flanged head and shank portions of uniform diameter for connecting said top strut, said bottom strut, said first chord and said second chord to said shear-resisting element, said top and bottom struts and said first and second chords forming a supporting frame for said shear-resisting element, said shank portions of each of said nails being closely received by said shear-resisting element along said portion of said shank embedded in said shear-resisting element and one of said first chord, said second chord, said top strut or said bottom strut with said flanged head of said nails disposed adjacent to said distal face of said shear-resisting element;
 7. boundary edging members disposed on said shear-resisting element at said first and second side edges, each of said boundary edging members having an elongated leg that receives a plurality of said edge fasteners, each of said boundary edging members being pierced by said shank portions of said edge fasteners through said elongated leg and thereby strengthening the connection made by said edge fasteners piercing said boundary edging members;
- g. means for connecting said shear-resisting assembly to said top plate of said wall;
- h. means for connecting said shear-resisting assembly to said underlying structural component of said building.
- 11.** The wall of claim **10**, wherein said shear-resisting assembly further comprises:
- a. intermediate studs disposed between said top and bottom struts of said shear-resisting element;
 - b. means for connecting said intermediate studs to said top and bottom struts;
 - c. means for connecting said intermediate studs to said structural panels; and

23

wherein selected intermediate studs are disposed at said joints of said structural panels, serving to connect said structural panels together.

12. A wall designed to resist lateral forces imposed on a building incorporating said wall, said building having an underlying structural component supporting said wall, said wall comprising:

- a. a bottom plate resting on said underlying structural component of said building;
- b. means for connecting said bottom plate to said underlying structural component of said building;
- c. a plurality of vertically-disposed studs resting on said bottom plate;
- d. means for connecting said plurality of vertically-disposed studs to said bottom plate;
- e. a top plate resting on said vertically-disposed studs;
- f. means for connecting said top plate to said vertically-disposed studs;
- g. a shear resisting assembly connected to said top plate and also connected to said underlying structural component and disposed between said top plate and said underlying structural component, said shear-resisting assembly including,
 - 1. a planar shear-resisting element, said planar shear-resisting element having a proximal face and a distal face, a top edge, a bottom edge and first and second side edges, said shear-resisting assembly also including,
 - 2. a top strut connected to said proximal face near said top edge of said shear-resisting element, and disposed substantially parallel to said top plate of said wall,
 - 3. a bottom strut connected to said proximal face near said bottom edge of said shear-resisting element,
 - 4. a first chord connected to said proximal face near said first side edge of said shear-resisting element,
 - 5. a second chord connected to said proximal face near said second side edge of said shear-resisting element, and
 - 6. means for connecting said top strut, said bottom strut, said first chord and said second chord to said shear-

24

resisting element, said top and bottom struts and said first and second chords forming a supporting frame for said shear-resisting element, said means consisting of edge fasteners having shank portions;

- h. means for connecting said shear-resisting assembly to said top plate of said wall;
- i. means for connecting said shear-resisting assembly to said underlying structural component of said building;
- j. boundary edging members disposed on said shear-resisting element at said top and bottom edges and said first and second side edges that are pierced by said shank portions of said edge fasteners and thereby strengthen the connection made by said edge fasteners, and wherein said boundary edging members are u-shaped channels, having a pair of legs joined by a central member that embrace said shear-resisting element, each of said edge fasteners passing through each of said legs of said u-shaped channels; and wherein;
- k. said means for connecting said shear-resisting assembly to said underlying structural component is a foundation anchor anchored to said underlying structural component, said foundation anchor being designed to transmit lateral forces imposed on said underlying structural component to said shear resisting assembly, and said bottom strut is formed with an opening through which said foundation anchor passes, and said opening in said bottom strut is oversized to accommodate mis-installation of said foundation anchor in said underlying structural component, and epoxy is placed within said opening in said bottom strut to ensure close contact between said foundation anchor and said bottom strut.

13. The wall of claim 10, wherein said means for connecting said shear-resisting assembly to said underlying structural component of said building comprises: first and second anchor bolts that are anchored to said underlying structural component and are disposed near said first and second chords and first and second holdowns that receive said first and second anchor bolts.

* * * * *