

(12) STANDARD PATENT APPLICATION (11) Application No. AU 2023200402 A1
(19) AUSTRALIAN PATENT OFFICE

(54) Title
BATTERY CLAMP DEVICE

(51) International Patent Classification(s)
H01R 11/24 (2006.01) **H01R 11/28** (2006.01)
H01R 11/22 (2006.01)

(21) Application No: **2023200402** (22) Date of Filing: **2023.01.25**

(43) Publication Date: **2023.02.23**

(43) Publication Journal Date: **2023.02.23**

(62) Divisional of:
2020258854

(71) Applicant(s)
The NOCO Company

(72) Inventor(s)
NOOK, Jonathan Lewis;NOOK Sr., William Knight;STANFIELD, James Richard;UNDERHILL, Derek Michael

(74) Agent / Attorney
Griffith Hack, Level 15 376-390 Collins St, MELBOURNE, VIC, 3000, AU

ABSTRACT

A battery clamp having a first inner metal battery clamp member having a handle portion and a clamp portion, a second inner metal battery clamp member having a handle portion and a clamp portion, a first outer insulating battery clamp member having a handle portion and a clamp portion connected to the first inner metal battery clamp, and a second outer insulating battery clamp member having a handle portion and a clamp portion connected to the second inner metal battery clamp. The first inner metal battery clamp member and/or the second inner metal battery clamp member having a battery cable connector configured to allow a user to access the battery cable connector with the user's fingers or a tool while avoiding interference with the handle portions of the battery clamp.

5

TITLE

BATTERY CLAMP DEVICE

CROSS-REFERENCE TO RELATED APPLICATIONS

5 The present application is a divisional application of Australian Patent Application No. 2020258854, the entire content of which is incorporated herein by cross-reference.

FIELD

0 The present invention is directed to a battery clamp device for use, for example, with battery jump starting cables or battery jump starters.

BACKGROUND

Currently, there exists a number of battery clamps used on jump starting cables or battery jump starters.

5 There exists a need for an improved battery clamp.

SUMMARY

The present invention is directed to an improved battery clamp device.

One aspect of the present invention provides a battery clamp device, comprising:

20 a first inner metal battery clamp member having a handle portion and a clamp portion;

a second inner metal battery clamp member having a handle portion and a clamp portion;

a first outer insulating battery clamp member having a handle portion and a clamp portion connected to the first inner metal battery clamp;

a second outer insulating battery clamp member having a handle portion and a clamp portion connected to the second inner metal battery clamp;

5 a pivot pin pivotally connecting the first inner metal battery clamp member to the second inner metal battery clamp member; and

a battery cable connector provided at an end of at least one of the first inner metal battery clamp member and the second inner metal battery clamp member, the battery cable connector comprising a first cylindrical-shaped metal plate end section
0 defining a battery cable end receiver including a receiving end exposed to an exterior of the battery clamp device, the battery cable connector being configured to secure and anchor the battery cable end within the battery cable connector,

wherein the battery cable connector is configured to receive a battery cable end into the battery cable end receiver, and secure and anchor the battery cable end within
5 the battery cable connector.

Another aspect of the present invention provides a battery clamp device, comprising:

a first inner metal battery clamp member having a handle portion and a clamp portion;

20 a second inner metal battery clamp member having a handle portion and a clamp portion;

a first outer plastic battery clamp member connected to the first inner metal battery clamp;

a second outer plastic battery clamp member connected to the second inner metal battery clamp;

a pivot pin pivotally connecting the first inner metal battery clamp member to the second inner metal battery clamp member; and

5 a battery cable connector provided at an end of at least one of the first inner metal battery clamp member and the second inner metal battery clamp member, the battery cable connector having a first split cylindrical-shaped metal plate end section defining a battery cable end receiver including a receiving end exposed to an exterior of the battery clamp device, the battery cable end receiver configured to be pressed
0 inwardly or crimped closed,

wherein the battery cable connector is configured to receive a battery cable end into the battery cable end receiver, and then be pressed inwardly or crimped closed to secure and anchor the battery cable end within the battery cable connector.

A further aspect of the present invention provides a battery clamp device,
5 comprising:

a first inner metal battery clamp member having a handle portion and a clamp portion;

a second inner metal battery clamp member having a handle portion and a clamp portion;

20 a first outer plastic battery clamp member connected to the first inner metal battery clamp;

a second outer plastic battery clamp member connected to the second inner metal battery clamp;

a pivot pin pivotally connecting the first inner metal battery clamp member to the second inner metal battery clamp member; and

a battery cable connector provided at an end of at least one of the first inner metal battery clamp member and the second inner metal battery clamp member, the battery cable connector having a first split cylindrical-shaped metal plate end section transitioning into another split cylindrical-shaped metal plate together defining a battery cable end receiver including a receiving end exposed to an exterior of the battery clamp device, the battery cable end receiver configured to be pressed inwardly or crimped closed,

wherein the battery cable connector is configured to receive a battery cable end into the battery cable end receiver, and then be pressed inwardly or crimped close to secure and anchor the battery cable end within the battery cable connector.

Embodiments of the battery clamp device comprise or consist of an outer battery clamp connected to an inner battery clamp. The outer battery clamp, for example, can be made of an electrically insulating material and the inner battery clamp can be made of an electrically conductive material (e.g. metal). The inner battery clamp preferably nests within the outer battery clamp, and they are connected together (e.g. by snap fit connector and/or mechanical connection).

Embodiments of the battery clamp device are configured to facilitate connection with a battery cable. Preferably, the battery clamp device is configured to prevent mechanical interference with a user's fingers or a tool for connecting or disconnecting fastener connecting the battery cable to the battery clamp device. For example, the inner battery clamp may be provided with a cable connector configured to prevent

mechanical interference with handle portions of the battery clamp device by placing the cable connector at one end of at least one handle portion along with the cable connector having a cable end receiver oriented parallel to a center longitudinal axis of the at least one handle portion.

5 Also described herein is a battery clamp device, comprising or consisting of: a first inner metal battery clamp member having a handle portion and a clamp portion; a second inner metal battery clamp member having a handle portion and a clamp portion; a first outer insulating battery clamp member having a handle portion and a clamp portion connected to the first inner metal battery clamp; a second outer insulating
0 battery clamp member having a handle portion and a clamp portion connected to the second inner metal battery clamp; a pivot pin pivotally connecting the first inner metal battery clamp member to the second inner metal battery clamp member; and a battery cable connector connected to an end of least one of the first inner metal battery clamp member and the second inner metal battery clamp member, the battery cable connector
5 being a cylindrical-shaped metal plate end defining a battery cable end receiver, the battery cable connector being configured to secure and anchor the battery cable end within the battery cable end receiver, wherein the battery cable connector is configured to receive a battery cable end into the battery cable end receiver.

Also described herein is a battery clamp device, comprising or consisting of:
20 a first inner metal battery clamp member having a handle portion and a clamp portion; a second inner metal battery clamp member having a handle portion and a clamp portion; a first outer plastic battery clamp member connected to the first inner metal battery clamp; a second outer plastic battery clamp member connected to the second inner

metal battery clamp; a pivot pin pivotally connecting the first inner metal battery clamp member to the second inner metal battery clamp member; and a battery cable connector connected to an end of at least one of the first inner metal battery clamp member and the second inner metal battery clamp member, the battery cable connector having a split cylindrical-shaped metal plate end defining a battery cable end receiver configured to be crimped closed, wherein the battery cable connector is configured to receive a battery cable end into the battery cable end receiver, and then be crimped inwardly to close the split cylindrical-shaped metal plate end to secure and anchor the battery cable end within the battery cable end receiver of the battery cable connector.

Also described herein is a battery clamp device, comprising: a first inner metal battery clamp member having a handle portion and a clamp portion; a second inner metal battery clamp member having a handle portion and a clamp portion; a first outer plastic battery clamp member connected to the first inner metal battery clamp; a second outer plastic battery clamp member connected to the second inner metal battery clamp; a pivot pin pivotally connecting the first inner metal battery clamp member to the second inner metal battery clamp member; and a battery cable connector connected to an end of at least one of the first inner metal battery clamp member and the second inner metal battery clamp member, the battery cable connector having a split cylindrical-shaped metal plate end transitioning into a continuous cylindrical-shaped metal plate together defining a battery cable end receiver configured to be crimped closed, wherein the battery cable connector is configured to receive a battery cable end into the battery cable end receiver, and then be crimped inwardly to close the split cylindrical-shaped

metal plate end to secure and anchor the battery cable end within the battery cable end receiver of the battery cable connector.

Also described herein is a battery clamp device, comprising or consisting of: a first inner metal battery clamp member having a handle portion and a clamp portion; a second inner metal battery clamp member having a handle portion and a clamp portion; a first outer insulating battery clamp member having a handle portion and a clamp portion connected to the first inner metal battery clamp; a second outer insulating battery clamp member having a handle portion and a clamp portion connected to the second inner metal battery clamp; a pivot pin pivotally connecting the first inner metal battery clamp member to the second inner metal battery clamp member; and a battery cable connector connected to an end of least one of the first inner metal battery clamp member and the second inner metal battery clamp member, the battery cable connector being a cylindrical-shaped metal plate end defining a battery cable end receiver, the battery cable connector being configured to secure and anchor the battery cable end within the battery cable end receiver, wherein the battery cable connector is configured to receive a battery cable end into the battery cable end receiver, wherein the cylindrical-shaped metal plate end is a split cylindrical-shaped metal plate end.

Also described herein is a battery clamp device, comprising or consisting of: a first inner metal battery clamp member having a handle portion and a clamp portion; a second inner metal battery clamp member having a handle portion and a clamp portion; a first outer insulating battery clamp member having a handle portion and a clamp portion connected to the first inner metal battery clamp; a second outer insulating battery clamp member having a handle portion and a clamp portion connected to the

second inner metal battery clamp; a pivot pin pivotally connecting the first inner metal battery clamp member to the second inner metal battery clamp member; and a battery cable connector connected to an end of least one of the first inner metal battery clamp member and the second inner metal battery clamp member, the battery cable connector being a cylindrical-shaped metal plate end defining a battery cable end receiver, the battery cable connector being configured to secure and anchor the battery cable end within the battery cable end receiver, wherein the battery cable connector is configured to receive a battery cable end into the battery cable end receiver, wherein the cylindrical-shaped metal plate end is a split cylindrical-shaped metal plate end, and wherein the edges of the split cylindrical-shaped metal plate end are spaced apart.

Also described herein is a battery clamp device, comprising or consisting of: a first inner metal battery clamp member having a handle portion and a clamp portion; a second inner metal battery clamp member having a handle portion and a clamp portion; a first outer insulating battery clamp member having a handle portion and a clamp portion connected to the first inner metal battery clamp; a second outer insulating battery clamp member having a handle portion and a clamp portion connected to the second inner metal battery clamp; a pivot pin pivotally connecting the first inner metal battery clamp member to the second inner metal battery clamp member; and a battery cable connector connected to an end of least one of the first inner metal battery clamp member and the second inner metal battery clamp member, the battery cable connector being a cylindrical-shaped metal plate end defining a battery cable end receiver, the battery cable connector being configured to secure and anchor the battery cable end within the battery cable end receiver, wherein the battery cable connector is configured

to receive a battery cable end into the battery cable end receiver, wherein the edges of the split cylindrical-shaped metal plate end abut each other when the split cylindrical-shaped metal plate is crimped inwardly.

Also described herein is a battery clamp device, comprising or consisting of: a first inner metal battery clamp member having a handle portion and a clamp portion; a second inner metal battery clamp member having a handle portion and a clamp portion; a first outer insulating battery clamp member having a handle portion and a clamp portion connected to the first inner metal battery clamp; a second outer insulating battery clamp member having a handle portion and a clamp portion connected to the second inner metal battery clamp; a pivot pin pivotally connecting the first inner metal battery clamp member to the second inner metal battery clamp member; and a battery cable connector connected to an end of least one of the first inner metal battery clamp member and the second inner metal battery clamp member, the battery cable connector being a cylindrical-shaped metal plate end defining a battery cable end receiver, the battery cable connector being configured to secure and anchor the battery cable end within the battery cable end receiver, wherein the battery cable connector is configured to receive a battery cable end into the battery cable end receiver, wherein the cylindrical-shaped metal plate end is a split cylindrical-shaped metal plate end, and wherein the edges of the split cylindrical-shaped metal plate having interlocking fingers.

Also described herein is a battery clamp device, comprising or consisting of: a first inner metal battery clamp member having a handle portion and a clamp portion; a second inner metal battery clamp member having a handle portion and a clamp portion; a first outer insulating battery clamp member having a handle portion and a clamp

portion connected to the first inner metal battery clamp; a second outer insulating battery clamp member having a handle portion and a clamp portion connected to the second inner metal battery clamp; a pivot pin pivotally connecting the first inner metal battery clamp member to the second inner metal battery clamp member; and a battery cable connector connected to an end of least one of the first inner metal battery clamp member and the second inner metal battery clamp member, the battery cable connector being a cylindrical-shaped metal plate end defining a battery cable end receiver, the battery cable connector being configured to secure and anchor the battery cable end within the battery cable end receiver, wherein the cylindrical-shaped metal plate end is a continuous cylindrical-shaped metal plate end configured to be crimped inwardly to secure and anchor the battery cable end within the battery cable end receiver.

Also described herein is a battery clamp device, comprising or consisting of: a first inner metal battery clamp member having a handle portion and a clamp portion; a second inner metal battery clamp member having a handle portion and a clamp portion; a first outer insulating battery clamp member having a handle portion and a clamp portion connected to the first inner metal battery clamp; a second outer insulating battery clamp member having a handle portion and a clamp portion connected to the second inner metal battery clamp; a pivot pin pivotally connecting the first inner metal battery clamp member to the second inner metal battery clamp member; and a battery cable connector connected to an end of least one of the first inner metal battery clamp member and the second inner metal battery clamp member, the battery cable connector being a cylindrical-shaped metal plate end defining a battery cable end receiver, the battery cable connector being configured to secure and anchor the battery cable end

within the battery cable end receiver, wherein the cylindrical-shaped metal plate end is a continuous cylindrical-shaped metal plate end having one or more threaded holes for each accommodating a set screw for securing the battery cable end within the battery cable end receiver.

5 Also described herein is a battery clamp device, comprising or consisting of: a first inner metal battery clamp member having a handle portion and a clamp portion; a second inner metal battery clamp member having a handle portion and a clamp portion; a first outer insulating battery clamp member having a handle portion and a clamp portion connected to the first inner metal battery clamp; a second outer insulating
0 battery clamp member having a handle portion and a clamp portion connected to the second inner metal battery clamp; a pivot pin pivotally connecting the first inner metal battery clamp member to the second inner metal battery clamp member; and a battery cable connector connected to an end of least one of the first inner metal battery clamp member and the second inner metal battery clamp member, the battery cable connector
5 being a cylindrical-shaped metal plate end defining a battery cable end receiver, the battery cable connector being configured to secure and anchor the battery cable end within the battery cable end receiver, wherein the battery cable connector comprises a split cylindrical-shaped metal plate end transitioning into a continuous cylindrical-shaped metal plate together defining a battery cable end receiver.

20 Also described herein is a battery clamp device, comprising or consisting of: a first inner metal battery clamp member having a handle portion and a clamp portion; a second inner metal battery clamp member having a handle portion and a clamp portion; a first outer insulating battery clamp member having a handle portion and a clamp

portion connected to the first inner metal battery clamp; a second outer insulating battery clamp member having a handle portion and a clamp portion connected to the second inner metal battery clamp; a pivot pin pivotally connecting the first inner metal battery clamp member to the second inner metal battery clamp member; and a battery cable connector connected to an end of least one of the first inner metal battery clamp member and the second inner metal battery clamp member, the battery cable connector being a cylindrical-shaped metal plate end defining a battery cable end receiver, the battery cable connector being configured to secure and anchor the battery cable end within the battery cable end receiver, wherein the battery cable connector comprises a split cylindrical-shaped metal plate end transitioning into a continuous cylindrical-shaped metal plate together defining a battery cable end receiver, and wherein a diameter of the split cylindrical-shaped metal plate end transitions downwardly into the continuous cylindrical-shaped metal plate a diameter less than the diameter of the split cylindrical-shaped metal plate end.

Also described herein is a battery clamp device, comprising or consisting of: a first inner metal battery clamp member having a handle portion and a clamp portion; a second inner metal battery clamp member having a handle portion and a clamp portion; a first outer insulating battery clamp member having a handle portion and a clamp portion connected to the first inner metal battery clamp; a second outer insulating battery clamp member having a handle portion and a clamp portion connected to the second inner metal battery clamp; a pivot pin pivotally connecting the first inner metal battery clamp member to the second inner metal battery clamp member; and a battery cable connector connected to an end of least one of the first inner metal battery clamp

member and the second inner metal battery clamp member, the battery cable connector being a cylindrical-shaped metal plate end defining a battery cable end receiver, the battery cable connector being configured to secure and anchor the battery cable end within the battery cable end receiver, wherein the battery cable connector comprises a split cylindrical-shaped metal plate end transitioning into a continuous cylindrical-shaped metal plate together defining a battery cable end receiver, and wherein the continuous cylindrical-shaped metal plate transitions into a funnel-shaped portion having an increasing diameter.

Also described herein is a battery clamp device, comprising or consisting of: a first inner metal battery clamp member having a handle portion and a clamp portion; a second inner metal battery clamp member having a handle portion and a clamp portion; a first outer insulating battery clamp member having a handle portion and a clamp portion connected to the first inner metal battery clamp; a second outer insulating battery clamp member having a handle portion and a clamp portion connected to the second inner metal battery clamp; a pivot pin pivotally connecting the first inner metal battery clamp member to the second inner metal battery clamp member; and a battery cable connector connected to an end of least one of the first inner metal battery clamp member and the second inner metal battery clamp member, the battery cable connector being a cylindrical-shaped metal plate end defining a battery cable end receiver, the battery cable connector being configured to secure and anchor the battery cable end within the battery cable end receiver, wherein at least one of the first inner metal battery clamp member and the second inner metal battery clamp member have a U-shaped transverse cross section extending along a length of the at least one of the first inner

metal battery clamp member and the second inner metal battery clamp member providing a pair of spaced apart inner edges, the U-shaped transverse cross section transitioning into the battery cable connector.

5 Also described herein is a battery clamp device, comprising or consisting of: a first inner metal battery clamp member having a handle portion and a clamp portion; a second inner metal battery clamp member having a handle portion and a clamp portion; a first outer insulating battery clamp member having a handle portion and a clamp portion connected to the first inner metal battery clamp; a second outer insulating battery clamp member having a handle portion and a clamp portion connected to the second inner metal battery clamp; a pivot pin pivotally connecting the first inner metal battery clamp member to the second inner metal battery clamp member; and a battery cable connector connected to an end of least one of the first inner metal battery clamp member and the second inner metal battery clamp member, the battery cable connector being a cylindrical-shaped metal plate end defining a battery cable end receiver, the battery cable connector being configured to secure and anchor the battery cable end within the battery cable end receiver, wherein the first inner metal battery clamp member is provided with a pair of pivot plate portions and the second inner metal battery clamp member is provided with a pair of pivot plate portions, wherein the pair of pivot plate portions of the first inner metal battery clamp member overlap with the pair of pivot plate portions of the second inner metal battery clamp member.

0
5
20

Also described herein is a battery clamp device, comprising or consisting of: a first inner metal battery clamp member having a handle portion and a clamp portion; a second inner metal battery clamp member having a handle portion and a clamp portion;

5 a first outer insulating battery clamp member having a handle portion and a clamp portion connected to the first inner metal battery clamp; a second outer insulating battery clamp member having a handle portion and a clamp portion connected to the second inner metal battery clamp; a pivot pin pivotally connecting the first inner metal battery clamp member to the second inner metal battery clamp member; and a battery cable connector connected to an end of least one of the first inner metal battery clamp member and the second inner metal battery clamp member, the battery cable connector being a cylindrical-shaped metal plate end defining a battery cable end receiver, the battery cable connector being configured to secure and anchor the battery cable end
0 within the battery cable end receiver, wherein the first inner metal battery clamp member is provided with a pair of pivot plate portions and the second inner metal battery clamp member is provided with a pair of pivot plate portions, wherein the pair of pivot plate portions of the first inner metal battery clamp member overlap with the pair of pivot plate portions of the second inner metal battery clamp member, wherein the pair of
5 pivot plate portions of the first inner metal battery clamp member are provided with arc-shaped flanges protruding outwardly from the sides of the first inner metal battery clamp member to accommodate the pivot plate portions of the second inner metal battery clamp, wherein the pivot plate portions of the second inner metal battery clamp are arc-shaped and nest within the arc-shaped flanges protruding outwardly from the sides of
20 the first inner metal battery clamp.

Also described herein is a battery clamp device, comprising or consisting of: a first inner metal battery clamp member having a handle portion and a clamp portion; a second inner metal battery clamp member having a handle portion and a clamp portion;

5 a first outer insulating battery clamp member having a handle portion and a clamp portion connected to the first inner metal battery clamp; a second outer insulating battery clamp member having a handle portion and a clamp portion connected to the second inner metal battery clamp; a pivot pin pivotally connecting the first inner metal battery clamp member to the second inner metal battery clamp member; and a battery cable connector connected to an end of least one of the first inner metal battery clamp member and the second inner metal battery clamp member, the battery cable connector being a cylindrical-shaped metal plate end defining a battery cable end receiver, the battery cable connector being configured to secure and anchor the battery cable end
0 within the battery cable end receiver, wherein the first inner metal battery clamp member having the handle portion and the clamp portion nests within at least a portion of the first outer insulating battery clamp member having the handle portion and the clamp portion connected to the first inner metal battery clamp, and wherein a second inner metal battery clamp member having a handle portion and a clamp portion nests
5 within at least a portion of the second outer insulating battery clamp member having the handle portion and the clamp portion connected to the second inner metal battery clamp.

20 Also described herein is a battery clamp device, comprising or consisting of: a first inner metal battery clamp member having a handle portion and a clamp portion; a second inner metal battery clamp member having a handle portion and a clamp portion; a first outer insulating battery clamp member having a handle portion and a clamp portion connected to the first inner metal battery clamp; a second outer insulating battery clamp member having a handle portion and a clamp portion connected to the

second inner metal battery clamp; a pivot pin pivotally connecting the first inner metal battery clamp member to the second inner metal battery clamp member; and a battery cable connector connected to an end of least one of the first inner metal battery clamp member and the second inner metal battery clamp member, the battery cable connector being a cylindrical-shaped metal plate end defining a battery cable end receiver, the battery cable connector being configured to secure and anchor the battery cable end within the battery cable end receiver, wherein the first inner metal battery clamp member having the handle portion and the clamp portion nests within at least a portion of the first outer insulating battery clamp member having the handle portion and the clamp portion connected to the first inner metal battery clamp, wherein a second inner metal battery clamp member having a handle portion and a clamp portion nests within at least a portion of the second outer insulating battery clamp member having the handle portion and the clamp portion connected to the second inner metal battery clamp, wherein the first outer insulating battery clamp member snap fits onto the first inner metal battery clamp member, and wherein the second outer insulating battery clamp member snap fits onto the second inner metal battery clamp member.

Also described herein is a battery clamp device, comprising or consisting of: a first inner metal battery clamp member having a handle portion and a clamp portion; a second inner metal battery clamp member having a handle portion and a clamp portion; a first outer insulating battery clamp member having a handle portion and a clamp portion connected to the first inner metal battery clamp; a second outer insulating battery clamp member having a handle portion and a clamp portion connected to the second inner metal battery clamp; a pivot pin pivotally connecting the first inner metal

battery clamp member to the second inner metal battery clamp member; and a battery cable connector connected to an end of least one of the first inner metal battery clamp member and the second inner metal battery clamp member, the battery cable connector being a cylindrical-shaped metal plate end defining a battery cable end receiver, the battery cable connector being configured to secure and anchor the battery cable end within the battery cable end receiver, wherein the first inner metal battery clamp member having the handle portion and the clamp portion nests within at least a portion of the first outer insulating battery clamp member having the handle portion and the clamp portion connected to the first inner metal battery clamp, wherein a second inner metal battery clamp member having a handle portion and a clamp portion nests within at least a portion of the second outer insulating battery clamp member having the handle portion and the clamp portion connected to the second inner metal battery clamp, wherein the first outer insulating battery clamp member snap fits onto the first inner metal battery clamp member, wherein the second outer insulating battery clamp member snap fits onto the second inner metal battery clamp member, wherein the first outer insulation battery clamp member comprises a snap fit protrusion snap fitting into a slot provided in the first inner metal battery clamp member, and wherein the second outer insulation battery clamp member comprises a snap fit protrusion snap fitting into a slot provided in the second inner metal battery clamp member.

Also described herein is a battery clamp device, comprising or consisting of: a first inner metal battery clamp member having a handle portion and a clamp portion; a second inner metal battery clamp member having a handle portion and a clamp portion; a first outer insulating battery clamp member having a handle portion and a clamp

portion connected to the first inner metal battery clamp; a second outer insulating battery clamp member having a handle portion and a clamp portion connected to the second inner metal battery clamp; a pivot pin pivotally connecting the first inner metal battery clamp member to the second inner metal battery clamp member; and a battery cable connector connected to an end of least one of the first inner metal battery clamp member and the second inner metal battery clamp member, the battery cable connector being a cylindrical-shaped metal plate end defining a battery cable end receiver, the battery cable connector being configured to secure and anchor the battery cable end within the battery cable end receiver, wherein the first inner metal battery clamp member having the handle portion and the clamp portion nests within at least a portion of the first outer insulating battery clamp member having the handle portion and the clamp portion connected to the first inner metal battery clamp, wherein a second inner metal battery clamp member having a handle portion and a clamp portion nests within at least a portion of the second outer insulating battery clamp member having the handle portion and the clamp portion connected to the second inner metal battery clamp, wherein the first outer insulating battery clamp member snap fits onto the first inner metal battery clamp member, wherein the second outer insulating battery clamp member snap fits onto the second inner metal battery clamp member, wherein the first outer insulation battery clamp member comprises a snap fit protrusion snap fitting into a slot provided in the first inner metal battery clamp member, wherein the second outer insulation battery clamp member comprises a snap fit protrusion snap fitting into a slot provided in the second inner metal battery clamp member, wherein the first outer insulation battery clamp member comprises a plurality of spaced apart snap fit

protrusions snap fitting into a plurality of spaced apart slots, respectively, in the first inner metal battery clamp member, and wherein the second outer insulation battery clamp member comprises a plurality of spaced apart snap fit protrusions snap fitting into a plurality of spaced apart slots provided in the second inner metal battery clamp member.

Also described herein is a battery clamp device, comprising or consisting of: a first inner metal battery clamp member having a handle portion and a clamp portion; a second inner metal battery clamp member having a handle portion and a clamp portion; a first outer insulating battery clamp member having a handle portion and a clamp portion connected to the first inner metal battery clamp; a second outer insulating battery clamp member having a handle portion and a clamp portion connected to the second inner metal battery clamp; a pivot pin pivotally connecting the first inner metal battery clamp member to the second inner metal battery clamp member; and a battery cable connector connected to an end of least one of the first inner metal battery clamp member and the second inner metal battery clamp member, the battery cable connector being a cylindrical-shaped metal plate end defining a battery cable end receiver, the battery cable connector being configured to secure and anchor the battery cable end within the battery cable end receiver, wherein the first inner metal battery clamp member having the handle portion and the clamp portion nests within at least a portion of the first outer insulating battery clamp member having the handle portion and the clamp portion connected to the first inner metal battery clamp, wherein a second inner metal battery clamp member having a handle portion and a clamp portion nests within at least a portion of the second outer insulating battery clamp member having the

5 handle portion and the clamp portion connected to the second inner metal battery
clamp, wherein the first outer insulating battery clamp member snap fits onto the first
inner metal battery clamp member, wherein the second outer insulating battery clamp
member snap fits onto the second inner metal battery clamp member, wherein the first
0 outer insulation battery clamp member comprises a snap fit protrusion snap fitting into a
slot provided in the first inner metal battery clamp member, wherein the second outer
insulation battery clamp member comprises a snap fit protrusion snap fitting into a slot
provided in the second inner metal battery clamp member, and wherein each snap fit
protrusion is split into two protrusion portions each having an edge barb portion to grip
inner edges of respective slots after being snap fitted to prevent disconnection of each
snap fit protrusion from each respective slot.

Also described herein is a battery clamp device, comprising or consisting of: a
first inner metal battery clamp member having a handle portion and a clamp portion; a
second inner metal battery clamp member having a handle portion and a clamp portion;
5 a first outer insulating battery clamp member having a handle portion and a clamp
portion connected to the first inner metal battery clamp; a second outer insulating
battery clamp member having a handle portion and a clamp portion connected to the
second inner metal battery clamp; a pivot pin pivotally connecting the first inner metal
battery clamp member to the second inner metal battery clamp member; and a battery
20 cable connector connected to an end of least one of the first inner metal battery clamp
member and the second inner metal battery clamp member, the battery cable connector
being a cylindrical-shaped metal plate end defining a battery cable end receiver, the
battery cable connector being configured to secure and anchor the battery cable end

within the battery cable end receiver, wherein the first inner metal battery clamp member is provided with a pair of pivot plate portions and the second inner metal battery clamp member is provided with a pair of pivot plate portions, wherein the pair of pivot plate portions of the first inner metal battery clamp member overlap with the pair of pivot plate portions of the second inner metal battery clamp member, wherein the pair of pivot plate portions of the first inner metal battery clamp member are provided with arc-shaped flanges protruding outwardly from the sides of the first inner metal battery clamp member to accommodate the pivot plate portions of the second inner metal battery clamp, wherein the pivot plate portions of the second inner metal battery clamp are arc-shaped and nest within the arc-shaped flanges protruding outwardly from the sides of the first inner metal battery clamp, wherein the arc-shaped flanges protruding outwardly from the sides of the first inner metal battery clamp member nest within arc-shaped inner edge portions of the first outer insulating battery clamp member, and wherein the arc-shaped pivot plate portions of the first inner metal battery clamp nest with arc-shaped inner edge portions of the second outer insulating battery clamp member.

Also described herein is a battery clamp device, comprising or consisting of: a first inner metal battery clamp member having a handle portion and a clamp portion; a second inner metal battery clamp member having a handle portion and a clamp portion; a first outer insulating battery clamp member having a handle portion and a clamp portion connected to the first inner metal battery clamp; a second outer insulating battery clamp member having a handle portion and a clamp portion connected to the second inner metal battery clamp; a pivot pin pivotally connecting the first inner metal battery clamp member to the second inner metal battery clamp member; and a battery

5 cable connector connected to an end of least one of the first inner metal battery clamp member and the second inner metal battery clamp member, the battery cable connector being a cylindrical-shaped metal plate end defining a battery cable end receiver, the battery cable connector being configured to secure and anchor the battery cable end within the battery cable end receiver, wherein the handle portion of the first outer insulating battery clamp member is provided with a protrusion, and wherein the handle portion of the second outer insulating battery clamp member is provided with a protrusion.

0 Also described herein is a battery clamp device, comprising or consisting of: a first inner metal battery clamp member having a handle portion and a clamp portion; a second inner metal battery clamp member having a handle portion and a clamp portion; a first outer insulating battery clamp member having a handle portion and a clamp portion connected to the first inner metal battery clamp; a second outer insulating battery clamp member having a handle portion and a clamp portion connected to the second inner metal battery clamp; a pivot pin pivotally connecting the first inner metal battery clamp member to the second inner metal battery clamp member; and a battery cable connector connected to an end of least one of the first inner metal battery clamp member and the second inner metal battery clamp member, the battery cable connector being a cylindrical-shaped metal plate end defining a battery cable end receiver, the battery cable connector being configured to secure and anchor the battery cable end within the battery cable end receiver, wherein the handle portion of the first outer insulating battery clamp member is provided with a protrusion, wherein the handle portion of the second outer insulating battery clamp member is provided with a

5

20

protrusion, wherein the protrusions form an X-shaped protrusion when the handle portions are squeezed together.

BRIEF DESCRIPTION OF DRAWINGS

5 FIG. 1 is a perspective view of a positive polarity battery clamp according to an embodiment of the present invention.

FIG. 2 is a left side view of the battery clamp shown in FIG. 1.

FIG. 3 is a right side view of the battery clamp shown in FIG. 1.

FIG. 4 is a front view of the battery clamp shown in FIG. 1.

0 FIG. 5 is a rear view of the battery clamp shown in FIG. 1.

FIG. 6 is a top view of the battery clamp shown in FIG. 1.

FIG. 7 is a bottom view of the battery clamp shown in FIG. 1.

FIG. 8 is a perspective view of a negative polarity battery clamp according to an embodiment of the present invention, the same as the positive polarity battery clamp shown in FIG. 1 except for a negative polarity symbol instead of a positive polarity symbol.

5 FIG. 9 is a perspective view of an inner battery clamp part of the battery clamps shown in FIGS. 1 and 8.

FIG. 10 is a right side view of the battery clamp part shown in FIG. 9.

20 FIG. 11 is a left side view of the battery clamp part shown in FIG. 9.

FIG. 12 is a front view of the battery clamp part shown in FIG. 9.

FIG. 13 is a rear view of the battery clamp part shown in FIG. 9.

FIG. 14 is a top view of the battery clamp part shown in FIG. 9.

FIG. 15 is a bottom view of the battery clamp part shown in FIG. 9.

FIG. 16 is a side view of the pin.

FIG. 17 is a side view showing the connection between the battery cable end and the battery cable end connector.

FIG. 18 is a side view showing the connection between the battery cable end and the battery cable end connector.

FIG. 19 is a perspective view of a spring part of the battery clamp shown in FIG. 1 and the inner battery clamp part shown in FIG. 9.

0 DETAILED DESCRIPTION

A battery clamp device 10 according to an embodiment of the present invention is shown in FIGS. 1-18. The battery clamp device 10 comprises an outer battery clamp 10A connected to an inner battery clamp 10B, as shown in FIG. 1.

The outer battery clamp portion 10A can be made, for example, of an electrically insulating material (e.g. resin, synthetic resin, plastic, rubber, fiberglass, composite, or other suitable electrical insulating material). The inner battery clamp portion 10B can be made, for example, of an electrically conductive material (e.g. metal, steel, metal alloy, steel alloy, plated steel, chrome plated steel, nickel plated steel, aluminum, anodized aluminum copper, or other suitable electrically conductive material).

20 The outer battery clamp portion 10A comprises a first outer battery clamp member 12 (e.g. made of plastic injection molded material) having an outer handle portion 14 and outer clamp portion 16 and a second outer battery clamp member 20

(e.g. made of plastic injection molded material) having an outer handle portion 22 and an outer clamp portion 24, as shown in FIG. 1.

The outer handle portion 14 is provided with an outer handle surface 14A and protrusions 14B, 14C. The outer handle portion 22 is provided with an outer handle surface 22A and protrusions 22B, 22C. It is noted that the protrusions 14B, 14C, 22B, 22C form an X-shaped protrusion together when the outer handle portions 14, 22, for example, are squeezed together by a user.

The outer clamp portion 16 is provided with a protrusion 16A and a raised positive (+) polarity symbol 16B. The outer clamp portion 24 is provided with a protrusion 24A (FIG. 3) and a raised positive (+) polarity symbol 24B.

The first battery clamp member 12 is provided with arc-shaped inner edges 18 located on both sides of the first battery clamp member 12. The second battery clamp member 22 is provided with arc-shaped inner edges 26 located on both sides of the second battery clamp member 22. See FIGS. 4 and 5.

The inner battery clamp device 10B comprises a first inner battery clamp portion 112 made of conductive metal (e.g. made from stamped or forged metal plate) having an inner handle portion 114 and an inner clamp portion 116. The first inner battery clamp member 112 is pivotally connected together (e.g. via pivot pin 130, see FIG. 9) to a second inner battery clamp portion 120 having an inner handle portion 122 and an inner clamp portion 124, as shown in FIG. 9.

The first inner battery clamp member 112 is provided with a slot 116C (FIG. 9) for providing a mechanical connection (e.g. snap fit connection) with a protrusion (e.g. snap fit protrusion 16D the same as snap fit protrusion 24D shown in FIG. 1) of the first outer

battery clamp member 12. The second inner battery clamp member 120 is provided with a slot 124C (FIG. 9) for providing a mechanical connection (e.g. snap fit connection) with a protrusion (e.g. snap fit protrusion 24D shown in FIG. 1) of the second outer battery clamp member 20.

5 The snap fit connections described above are located at the outer clamp portions 16, 24. Additional connections (e.g. mechanical connections, additional snap fit connections) can be provided on the outer handle portions 14, 22. For example, the outer handle portions 14, 22 can be provided with transverse cross members 14F, 14G, 22F, 22G (FIG. 7) configured for connecting to (e.g. capturing) the inner handle portions 0 114, 122. Specifically, the transverse cross members 14F, 22F wrap across and capture inner sides (e.g. inner edges) of the inner handle portions 114, 122. The transverse cross members 14G, 22G, wrap across and capture the edges and ends of the inner handle portions 114, 122. During assembly, each inner handle portion 114, 122 is slipped underneath of the transverse cross members 14F, 14G, 22F, 22G until the inner 5 handle portions 114, 122 bottom out within the cross member 22F, 22G, and then the outer clamp portions 16, 24 are snap fitted to the inner clamp portions 116, 124.

20 Again, the inner battery clamp 10B is made of an electrically conductive material such as metal. For example, the first inner battery clamp portion 112 and the second inner battery clamp portion 120 are made from stamped sheet metal (e.g. steel, aluminum, copper, brass, metal alloy, or other suitable electrically conductive material), and then metal plated (e.g. with chrome, nickel, metal alloy) to make corrosion resistant. The first inner battery clamp portion 112 and the second inner battery clamp portion 120

are then assembled together with spring 131 (FIGS. 17 and 18) and pivot pin 130 (FIG. 9).

The inner battery clamp 10B is configured for connection with a battery cable 154 (FIG. 16). For example, the inner handle portion 122 (FIG. 12) is fitted with a battery end connector 128, as shown in FIGS. 12, 15, 17, and 18. The battery cable connector 128, for example, comprises a first split cylindrical-shaped metal plate end section oriented parallel to a longitudinal axis of the inner handle portion 122. The first split cylindrical-shaped metal plate end section is in an open position (FIG. 17) readied for receiving the battery cable end 142A. Specifically, the battery cable 142 is provided with an exposed battery cable end 142 with the insulation 142B removed. The exposed battery cable end 142 is inserted into a receiver 128A of the battery cable connector 128, and then the battery cable connector 128 is pressed inwardly by force F (FIG. 17) or crimped closed to secure and anchor the exposed battery cable end 142 within the receiver 128A of the battery cable connector 128. Alternatively, the first split cylindrical-shaped metal plate end section can be a first continuous cylindrical-shaped metal plate end section. For example, the first continuous cylindrical-shaped metal plate end section along its side can be provided with one or more threaded through holes each accommodating a set screw for securing and anchoring the battery cable end 142A within the receiver 128A of the battery cable connector 128. Further, the battery cable end 142A (FIGS. 17 and 18) can be soldered and/or welded into the battery cable connector 128.

The edges of the battery cable connector 128 can be provided with interlacing fingers 128B, 128C, as shown in FIG. 17. The interlacing fingers 128B can be pressed

inwardly into the exposed battery cable end 142A to further grip strands of the exposed battery cable end 142A. In addition, the exposed battery cable end 142A can be soldered and/or welded to further secure and anchor the battery cable end 142A within the receiver 128A of the battery cable connector 128.

5 The battery cable connector 128 comprises the first split cylindrical-shaped metal plate end section having initially spaced apart edges with interlacing fingers 128B, 128C and a second split cylindrical-shaped section 122F having initially spaced apart edges 122FA, 122FB, as shown in FIG. 17. After the battery cable end 142A of the battery cable 142 is fully inserted into the battery cable connector 128, the battery cable
0 connector 128 is pressed together and/or crimped together causing the spaced apart edges with interlacing fingers 128B, 128C to be forced together to abut each other along with the spaced apart edges 122FA, 122FB being also forced together to abut each other.

The battery cable connector 128 further comprises a third funnel-shaped metal
5 plate section having outwardly tapering walls 122E and a fourth section having a pair of spaced apart metal plates 140A, 140A. The metal plates 140A, 140A (FIGS. 15 and 18) of the fourth section can be pressed together to providing an additional gripping force onto the battery cable end 142B. In addition, the wall sections 140A, 140A can be
20 soldered and/or welded to the battery cable end 142A to enhance conductivity, and further secure and anchor the battery cable end 142A to the battery cable end connector 128.

As shown in FIG. 18, the wall thickness of the first split cylindrical-shaped metal plate end section 128 is greater than the wall thickness of the second split cylindrical-

shaped metal plate section 122F. Further, the inner diameter of the first split cylindrical-shaped end section 128 is the same as the inner diameter of the second split cylindrical-shaped metal plate section 122F. The greater wall thickness of the first split cylindrical-shaped metal plate section 128 enhances the amount of gripping force on the battery cable end after being pressed inwardly or crimped closed.

A spring 131 (FIG. 19) is installed within the inner battery clamp 10B to spring bias the outer clamp portions 12, 16 together. Specifically, the spring 131 is provided with a through hole 131B to accommodate the pivot pin 130 while the arm 131C having ends 131D contact an inner surface of the arm portions 114, 122 (FIG. 9) of the inner battery clamp 10B.

In the claims which follow and in the description of the invention, except where the context requires otherwise due to express language or necessary implication, the word “comprise” or variations such as “comprises” or “comprising” is used in an inclusive sense, i.e. to specify the presence of the stated features but not to preclude the presence or addition of further features in various embodiments of the invention.

CLAIMS

1. A battery clamp device, comprising:

5 a first inner metal battery clamp member having a handle portion and a clamp portion;

a second inner metal battery clamp member having a handle portion and a clamp portion;

a first outer insulating battery clamp member having a handle portion and a clamp portion connected to the first inner metal battery clamp;

0 a second outer insulating battery clamp member having a handle portion and a clamp portion connected to the second inner metal battery clamp;

a pivot pin pivotally connecting the first inner metal battery clamp member to the second inner metal battery clamp member; and

5 a battery cable connector provided at an end of at least one of the first inner metal battery clamp member and the second inner metal battery clamp member, the battery cable connector comprising a first cylindrical-shaped metal plate end section defining a battery cable end receiver including a receiving end exposed to an exterior of the battery clamp device, the battery cable connector being configured to secure and anchor the battery cable end within the battery cable connector,

20 wherein the battery cable connector is configured to receive a battery cable end into the battery cable end receiver, and secure and anchor the battery cable end within the battery cable connector.

2. A battery clamp device, comprising:
- a first inner metal battery clamp member having a handle portion and a clamp portion;
 - a second inner metal battery clamp member having a handle portion and a clamp portion;
 - a first outer plastic battery clamp member connected to the first inner metal battery clamp;
 - a second outer plastic battery clamp member connected to the second inner metal battery clamp;
 - a pivot pin pivotally connecting the first inner metal battery clamp member to the second inner metal battery clamp member; and
 - a battery cable connector provided at an end of at least one of the first inner metal battery clamp member and the second inner metal battery clamp member, the battery cable connector having a first split cylindrical-shaped metal plate end section defining a battery cable end receiver including a receiving end exposed to an exterior of the battery clamp device, the battery cable end receiver configured to be pressed inwardly or crimped closed,
- wherein the battery cable connector is configured to receive a battery cable end into the battery cable end receiver, and then be pressed inwardly or crimped closed to secure and anchor the battery cable end within the battery cable connector.

3. A battery clamp device, comprising:

a first inner metal battery clamp member having a handle portion and a clamp portion;

a second inner metal battery clamp member having a handle portion and a clamp portion;

a first outer plastic battery clamp member connected to the first inner metal battery clamp;

a second outer plastic battery clamp member connected to the second inner metal battery clamp;

a pivot pin pivotally connecting the first inner metal battery clamp member to the second inner metal battery clamp member; and

a battery cable connector provided at an end of at least one of the first inner metal battery clamp member and the second inner metal battery clamp member, the battery cable connector having a first split cylindrical-shaped metal plate end section transitioning into another split cylindrical-shaped metal plate together defining a battery cable end receiver including a receiving end exposed to an exterior of the battery clamp device, the battery cable end receiver configured to be pressed inwardly or crimped closed,

wherein the battery cable connector is configured to receive a battery cable end into the battery cable end receiver, and then be pressed inwardly or crimped close to secure and anchor the battery cable end within the battery cable connector.

4. The device according to claim 1, wherein the first cylindrical-shaped metal plate end section is a first split cylindrical-shaped metal plate end section.

5. The device according to claim 4, wherein inner edges of the first split cylindrical-shaped metal plate end section are initially spaced apart prior to connection with the battery cable end.

6. The device according to claim 5, wherein the edges of the first split cylindrical-shaped metal plate end section abut each other after the first split cylindrical-shaped metal plate is pressed inwardly or crimped closed to connect the battery cable end to the battery cable connector.

7. The device according to claim 4, wherein the edges of the first split cylindrical-shaped metal plate end section are provided with interlocking fingers.

8. The device according to claim 1, wherein the first cylindrical-shaped metal plate end section is a continuous cylindrical-shaped metal plate end configured to be pressed inwardly or crimped to secure and anchor the battery cable end within the battery cable connector.

9. The device according to claim 1, wherein the first cylindrical-shaped metal plate end section is a first continuous cylindrical-shaped metal plate end section having one

or more threaded holes each accommodating a set screw for securing the battery cable end within the battery cable connector.

5 10. The device according to claim 1, wherein the battery cable connector comprises a first split cylindrical-shaped metal plate end section transitioning into a second split cylindrical-shaped metal plate section.

0 11. The device according to claim 10, wherein the first split cylindrical-shaped metal plate end section has a greater wall thickness than that a wall thickness of the second split cylindrical shaped metal plate section.

12. The device according to claim 11, wherein the inner diameter of the first split cylindrical-shaped metal plate end section is same as an inner diameter of the second split cylindrical-shaped metal plate section.

5 13. The device according to claim 11, wherein the second split cylindrical-shaped metal plate section transitions into a third funnel-shaped metal plate section tapering outwardly with an increasing diameter along the length of the third funnel-shaped metal plate section.

20 14. The device according to claim 1, wherein at least one of the first inner metal battery clamp member and the second inner metal battery clamp member have a U-shaped transverse cross section extending along a length of the at least one of the first

inner metal battery clamp member and the second inner metal battery clamp member providing a pair of spaced apart inner edges, the U-shaped transverse cross section transitioning into the battery cable connector.

5 15. The device according to claim 1, wherein the first inner metal battery clamp member is provided with a pair of pivot plate portions and the second inner metal battery clamp member is provided with a pair of pivot plate portions, wherein the pair of pivot plate portions of the first inner metal battery clamp member overlap with the pair of pivot plate portions of the second inner metal battery clamp member.

0

16. The device according to claim 15, wherein the pair of pivot plate portions of the first inner metal battery clamp member are provided with arc-shaped flanges protruding outwardly from the sides of the first inner metal battery clamp member to accommodate the pivot plate portions of the second inner metal battery clamp, wherein the pivot plate portions of the second inner metal battery clamp are arc-shaped and nest within the arc-shaped flanges protruding outwardly from the sides of the first inner metal battery clamp.

17. The device according to claim 1,
20 wherein the inner battery clamp nests within the outer battery clamp.

18. The device according to claim 1,
wherein the first inner metal battery clamp member having the handle portion and the clamp portion nests within at least a portion of the first outer insulating battery clamp member having the handle portion and the clamp portion connected to the first inner metal battery clamp, and

wherein a second inner metal battery clamp member having a handle portion and a clamp portion nests within at least a portion of the second outer insulating battery clamp member having the handle portion and the clamp portion connected to the second inner metal battery clamp.

19. The device according to claim 18,
wherein the first outer insulating battery clamp member snap fits onto the first inner metal battery clamp member, and

wherein the second outer insulating battery clamp member snap fits onto the second inner metal battery clamp member.

20. The device according to claim 19,
wherein the first outer insulation battery clamp member comprises a snap fit protrusion snap fitting into a slot provided in the first inner metal battery clamp member, and

wherein the second outer insulation battery clamp member comprises a snap fit protrusion snap fitting into a slot provided in the second inner metal battery clamp member.

21. The device according to claim 20,
wherein the first outer insulation battery clamp member comprises a plurality of spaced apart snap fit protrusions snap fitting into a plurality of spaced apart slots, respectively, in the first inner metal battery clamp member, and

wherein the second outer insulation battery clamp member comprises a plurality of spaced apart snap fit protrusions snap fitting into a plurality of spaced apart slots provided in the second inner metal battery clamp member.

22. The device according to claim 20, wherein each snap fit protrusion is split into two protrusion portions each having an edge barb portion to grip inner edges of respective slots after being snap fitted to prevent disconnection of each snap fit protrusion from each respective slot.

23. The device according to claim 17,
wherein the arc-shaped flanges protruding outwardly from the sides of the first inner metal battery clamp member nest within arc-shaped inner edge portions of the first outer insulating battery clamp member, and

wherein the arc-shaped pivot plate portions of the first inner metal battery clamp nest with arc-shaped inner edge portions of the second outer insulating battery clamp member.

24. The device according to claim 1,
wherein the handle portion of the first outer insulating battery clamp member is provided with a protrusion, and
wherein the handle portion of the second outer insulating battery clamp member is provided with a protrusion.

25. The device according to claim 24, wherein the protrusions form an X-shaped protrusion when the handle portions are squeezed together.

PARENT CLAIMS

1. A battery clamp device, comprising:

a first inner metal battery clamp member having a handle portion and a clamp portion;

5 a second inner metal battery clamp member having a handle portion and a clamp portion;

a first outer insulating battery clamp member having a handle portion and a clamp portion connected to the first inner metal battery clamp;

0 a second outer insulating battery clamp member having a handle portion and a clamp portion connected to the second inner metal battery clamp;

a pivot pin pivotally connecting the first inner metal battery clamp member to the second inner metal battery clamp member; and

5 a battery cable connector provided at an end of at least one of the first inner metal battery clamp member and the second inner metal battery clamp member, the battery cable connector comprising a first cylindrical-shaped metal plate end section defining a battery cable end receiver, the battery cable connector being configured to secure and anchor the battery cable end within the battery cable connector,

20 wherein the battery cable connector is configured to receive a battery cable end into the battery cable end receiver, and secure and anchor the battery cable end within the battery cable connector.

2. A battery clamp device, comprising:

a first inner metal battery clamp member having a handle portion and a clamp portion;

a second inner metal battery clamp member having a handle portion and a clamp portion;

5 a first outer plastic battery clamp member connected to the first inner metal battery clamp;

a second outer plastic battery clamp member connected to the second inner metal battery clamp;

0 a pivot pin pivotally connecting the first inner metal battery clamp member to the second inner metal battery clamp member; and

a battery cable connector provided at an end of at least one of the first inner metal battery clamp member and the second inner metal battery clamp member, the battery cable connector having a first split cylindrical-shaped metal plate end section defining a battery cable end receiver configured to be pressed inwardly or crimped closed,

5 wherein the battery cable connector is configured to receive a battery cable end into the battery cable end receiver, and then be pressed inwardly or crimped closed to secure and anchor the battery cable end within the battery cable connector.

20 3. A battery clamp device, comprising:

a first inner metal battery clamp member having a handle portion and a clamp portion;

a second inner metal battery clamp member having a handle portion and a clamp portion;

a first outer plastic battery clamp member connected to the first inner metal battery clamp;

5 a second outer plastic battery clamp member connected to the second inner metal battery clamp;

a pivot pin pivotally connecting the first inner metal battery clamp member to the second inner metal battery clamp member; and

0 a battery cable connector provided at an end of at least one of the first inner metal battery clamp member and the second inner metal battery clamp member, the battery cable connector having a first split cylindrical-shaped metal plate end section transitioning into another split cylindrical-shaped metal plate together defining a battery cable end receiver configured to be pressed inwardly or crimped closed,

5 wherein the battery cable connector is configured to receive a battery cable end into the battery cable end receiver, and then be pressed inwardly or crimped close to secure and anchor the battery cable end within the battery cable connector.

4. The device according to claim 1, wherein the first cylindrical-shaped metal plate end section is a first split cylindrical-shaped metal plate end section.

20 5. The device according to claim 4, wherein inner edges of the first split cylindrical-shaped metal plate end section are initially spaced apart prior to connection with the battery cable end.

- 5 6. The device according to claim 5, wherein the edges of the first split cylindrical-shaped metal plate end section abut each other after the first split cylindrical-shaped metal plate is pressed inwardly or crimped closed to connect the battery cable end to the battery cable connector.
7. The device according to claim 4, wherein the edges of the first split cylindrical-shaped metal plate end section are provided with interlocking fingers.
- 0 8. The device according to claim 1, wherein the first cylindrical-shaped metal plate end section is a continuous cylindrical-shaped metal plate end configured to be pressed inwardly or crimped to secure and anchor the battery cable end within the battery cable connector.
- 5 9. The device according to claim 1, wherein the first cylindrical-shaped metal plate end section is a first continuous cylindrical-shaped metal plate end section having one or more threaded holes each accommodating a set screw for securing the battery cable end within the battery cable connector.
- 20 10. The device according to claim 1, wherein the battery cable connector comprises a first split cylindrical-shaped metal plate end section transitioning into a second split cylindrical-shaped metal plate section.

11. The device according to claim 10, wherein the first split cylindrical-shaped metal plate end section has a greater wall thickness than that a wall thickness of the second split cylindrical-shaped metal plate section.

5 12. The device according to claim 11, wherein the inner diameter of the first split cylindrical-shaped metal plate end section is same as an inner diameter of the second split cylindrical-shaped metal plate section.

13. The device according to claim 11, wherein the second split cylindrical-shaped
0 metal plate section transitions into a third funnel-shaped metal plate section tapering outwardly with an increasing diameter along the length of the third funnel-shaped metal plate section.

14. The device according to claim 1, wherein at least one of the first inner metal
5 battery clamp member and the second inner metal battery clamp member have a U-shaped transverse cross section extending along a length of the at least one of the first inner metal battery clamp member and the second inner metal battery clamp member providing a pair of spaced apart inner edges, the U-shaped transverse cross section transitioning into the battery cable connector.

20 15. The device according to claim 1, wherein the first inner metal battery clamp member is provided with a pair of pivot plate portions and the second inner metal battery clamp member is provided with a pair of pivot plate portions, wherein the pair of

pivot plate portions of the first inner metal battery clamp member overlap with the pair of pivot plate portions of the second inner metal battery clamp member.

5 16. The device according to claim 15, wherein the pair of pivot plate portions of the first inner metal battery clamp member are provided with arc-shaped flanges protruding outwardly from the sides of the first inner metal battery clamp member to accommodate the pivot plate portions of the second inner metal battery clamp, wherein the pivot plate portions of the second inner metal battery clamp are arc-shaped and nest within the arc-shaped flanges protruding outwardly from the sides of the first inner metal battery
0 clamp.

17. The device according to claim 1,
wherein the inner battery clamp nests within the outer battery clamp.

5 18. The device according to claim 1,
wherein the first inner metal battery clamp member having the handle portion and the clamp portion nests within at least a portion of the first outer insulating battery clamp member having the handle portion and the clamp portion connected to the first inner metal battery clamp, and

20 wherein a second inner metal battery clamp member having a handle portion and a clamp portion nests within at least a portion of the second outer insulating battery clamp member having the handle portion and the clamp portion connected to the second inner metal battery clamp.

19. The device according to claim 18,
wherein the first outer insulating battery clamp member snap fits onto the first
inner metal battery clamp member, and

5 wherein the second outer insulating battery clamp member snap fits onto the
second inner metal battery clamp member.

20. The device according to claim 19,
wherein the first outer insulation battery clamp member comprises a snap fit
0 protrusion snap fitting into a slot provided in the first inner metal battery clamp member,
and

wherein the second outer insulation battery clamp member comprises a snap fit
protrusion snap fitting into a slot provided in the second inner metal battery clamp
member.

5 21. The device according to claim 20,
wherein the first outer insulation battery clamp member comprises a plurality of
spaced apart snap fit protrusions snap fitting into a plurality of spaced apart slots,
respectively, in the first inner metal battery clamp member, and

20 wherein the second outer insulation battery clamp member comprises a plurality
of spaced apart snap fit protrusions snap fitting into a plurality of spaced apart slots
provided in the second inner metal battery clamp member.

5

22. The device according to claim 20, wherein each snap fit protrusion is split into two protrusion portions each having an edge barb portion to grip inner edges of respective slots after being snap fitted to prevent disconnection of each snap fit protrusion from each respective slot.

23. The device according to claim 17,
wherein the arc-shaped flanges protruding outwardly from the sides of the first inner metal battery clamp member nest within arc-shaped inner edge portions of the first outer insulating battery clamp member, and

0

wherein the arc-shaped pivot plate portions of the first inner metal battery clamp nest with arc-shaped inner edge portions of the second outer insulating battery clamp member.

24. The device according to claim 1,

5

wherein the handle portion of the first outer insulating battery clamp member is provided with a protrusion, and

wherein the handle portion of the second outer insulating battery clamp member is provided with a protrusion.

20

25. The device according to claim 24, wherein the protrusions form an X-shaped protrusion when the handle portions are squeezed together.

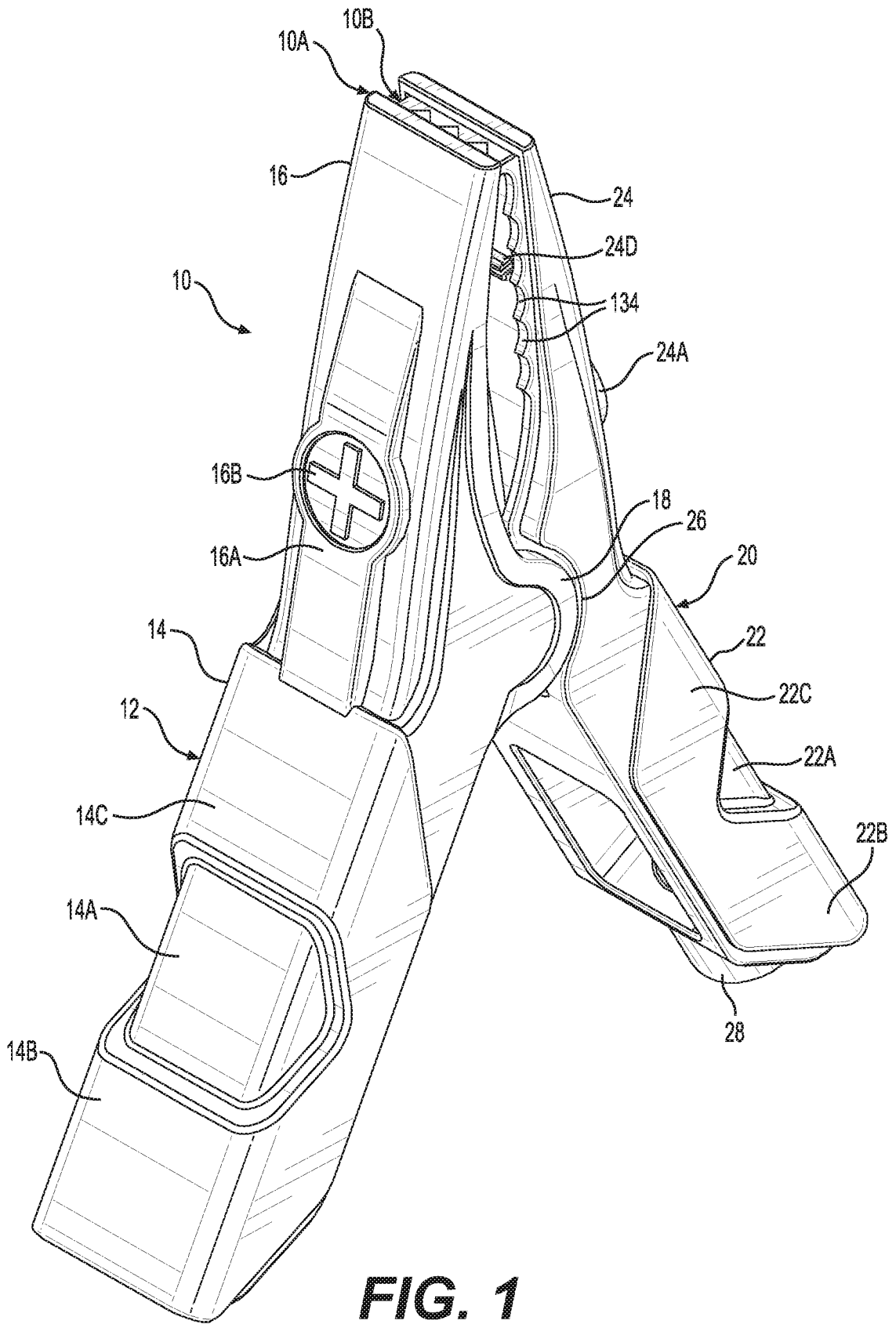

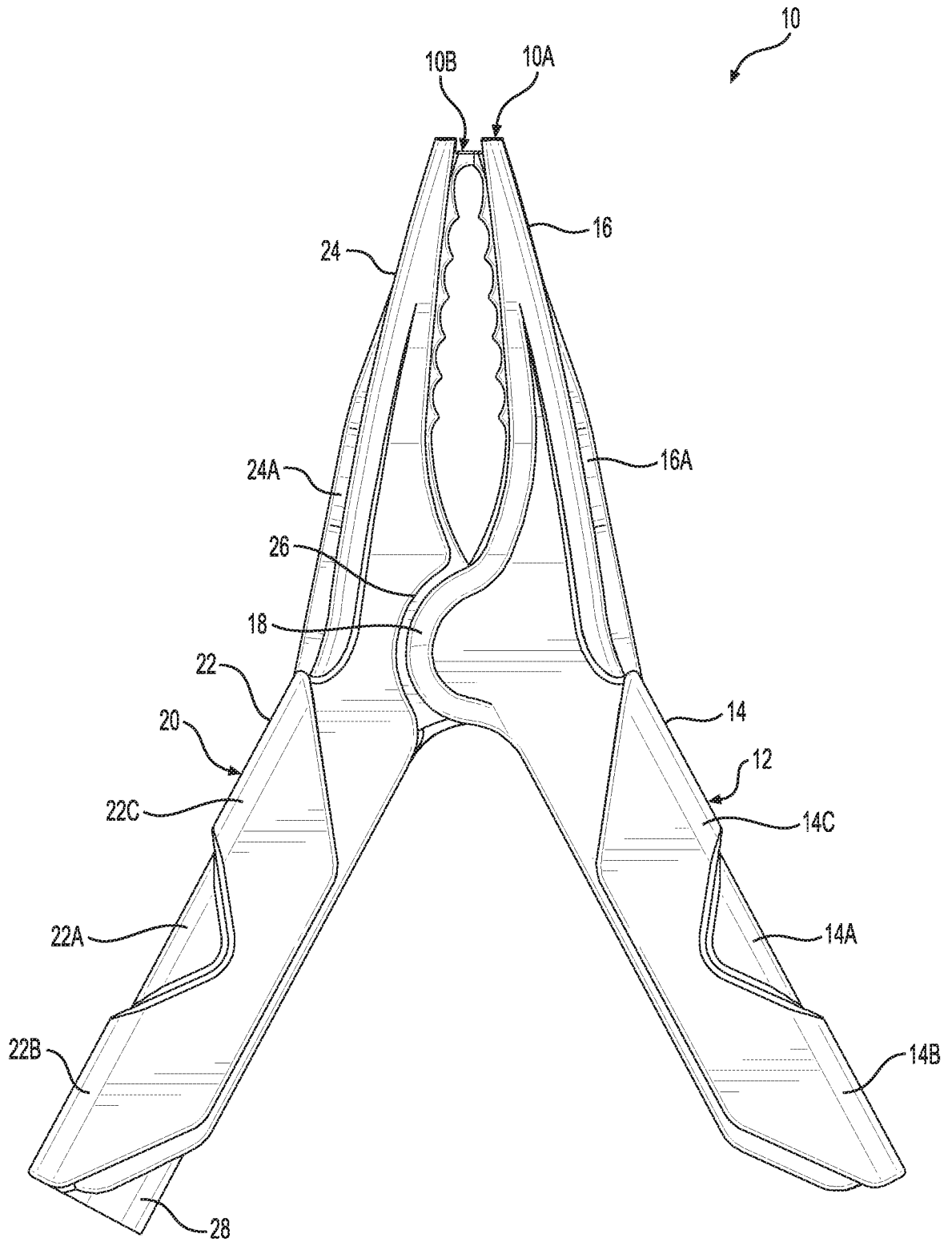

FIG. 2

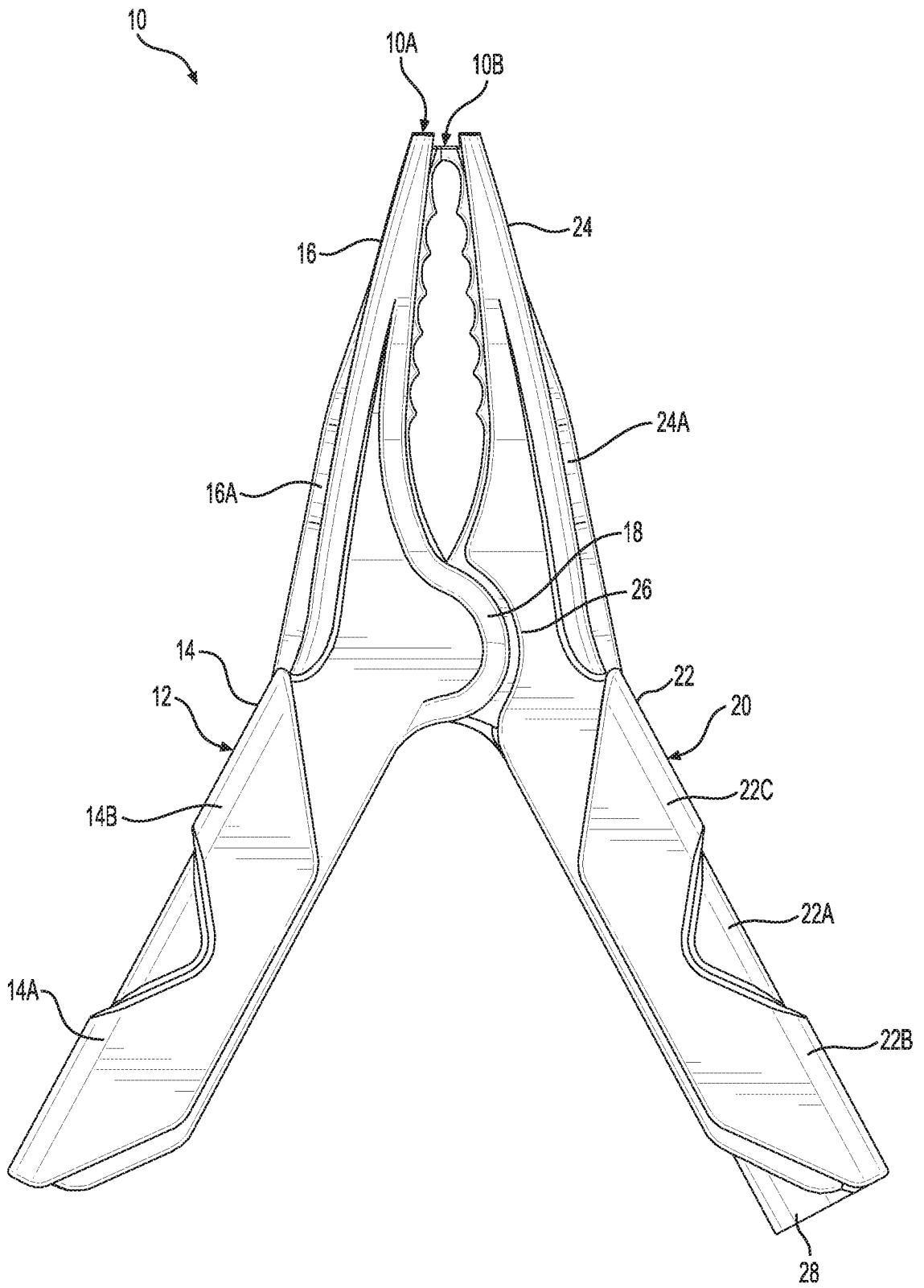

FIG. 3

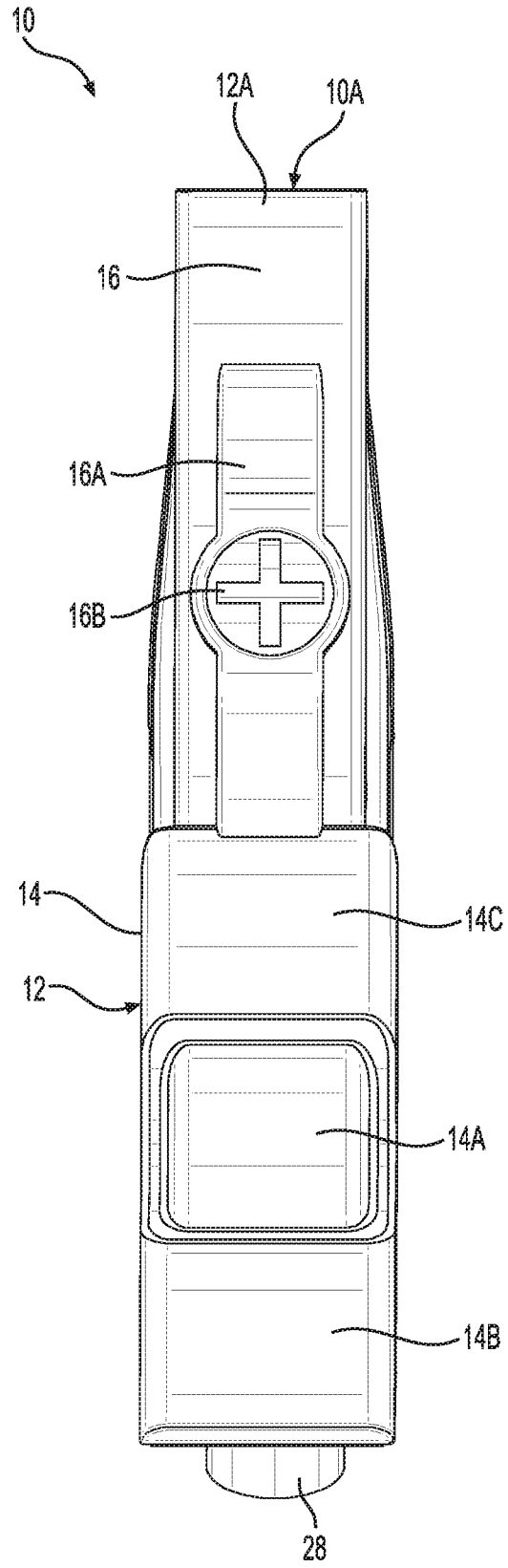

FIG. 4

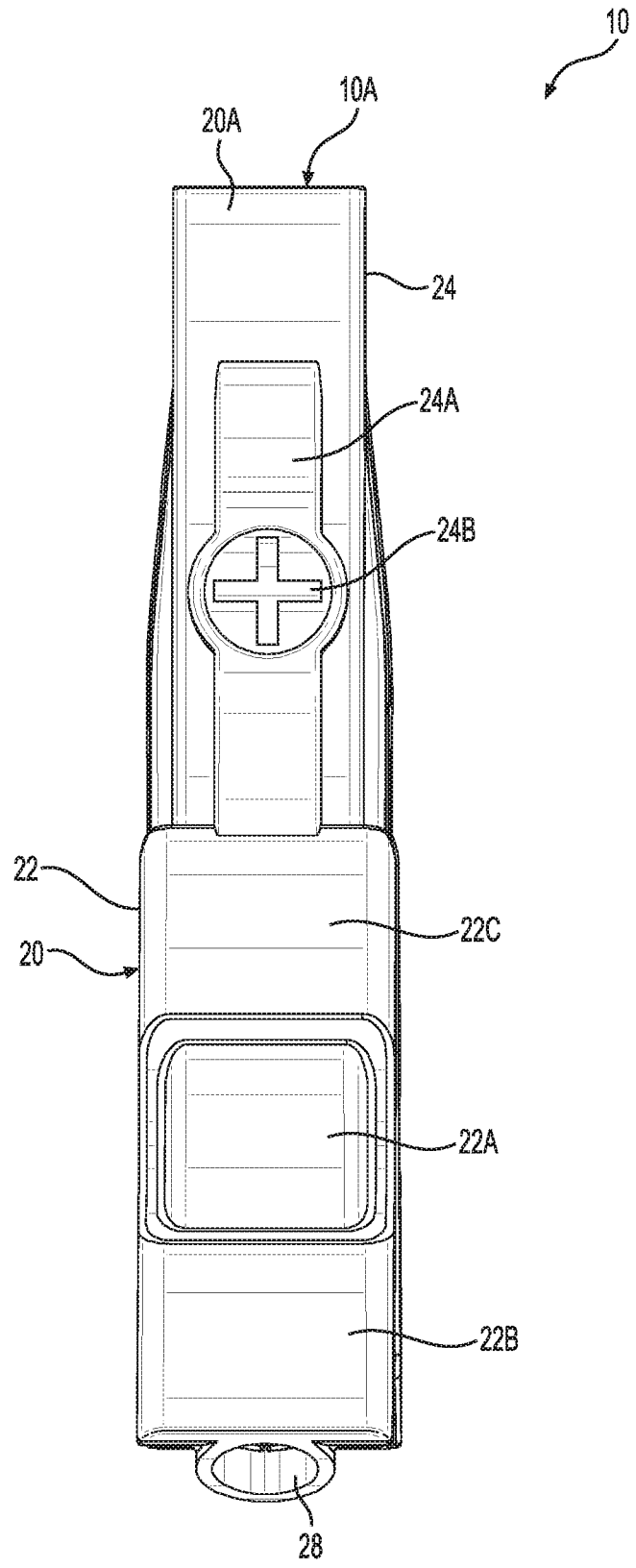

FIG. 5

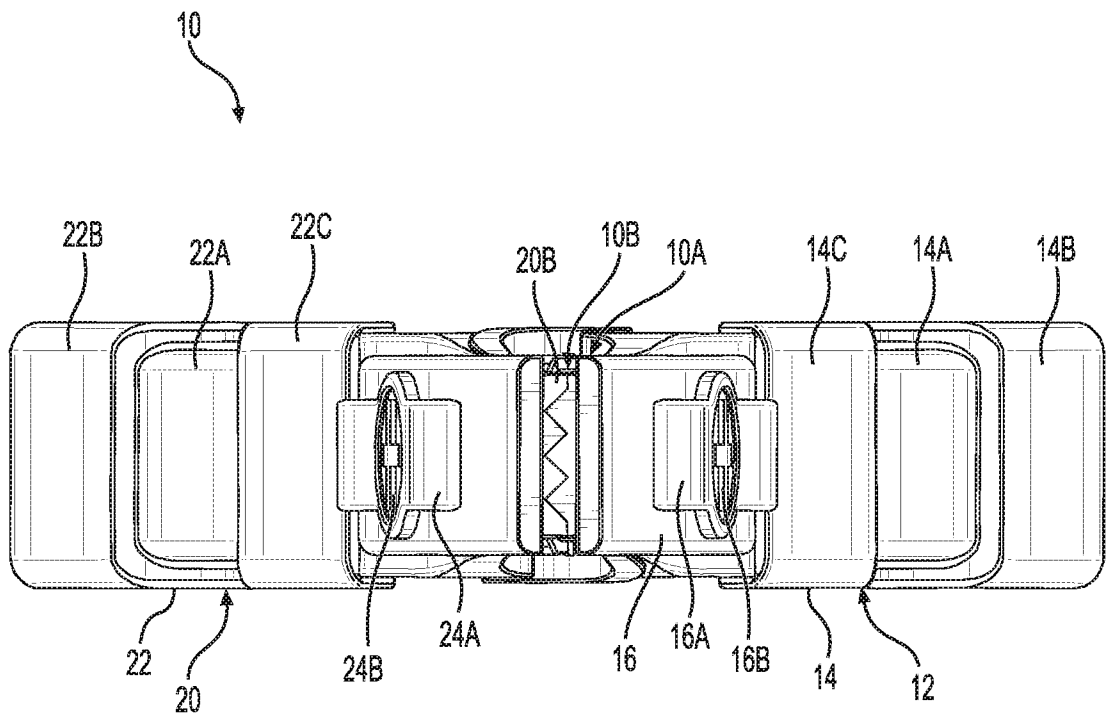

FIG. 6

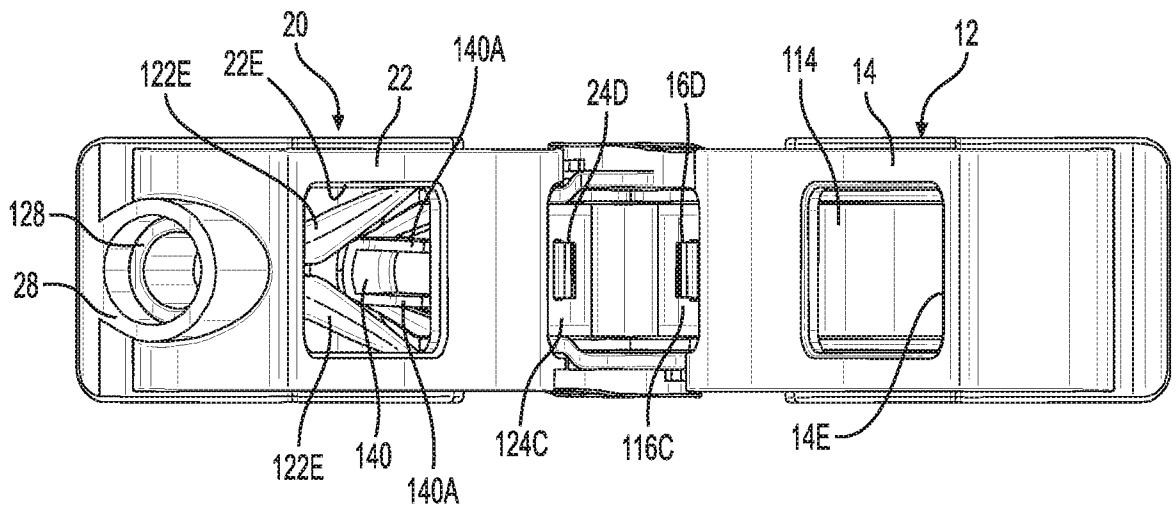
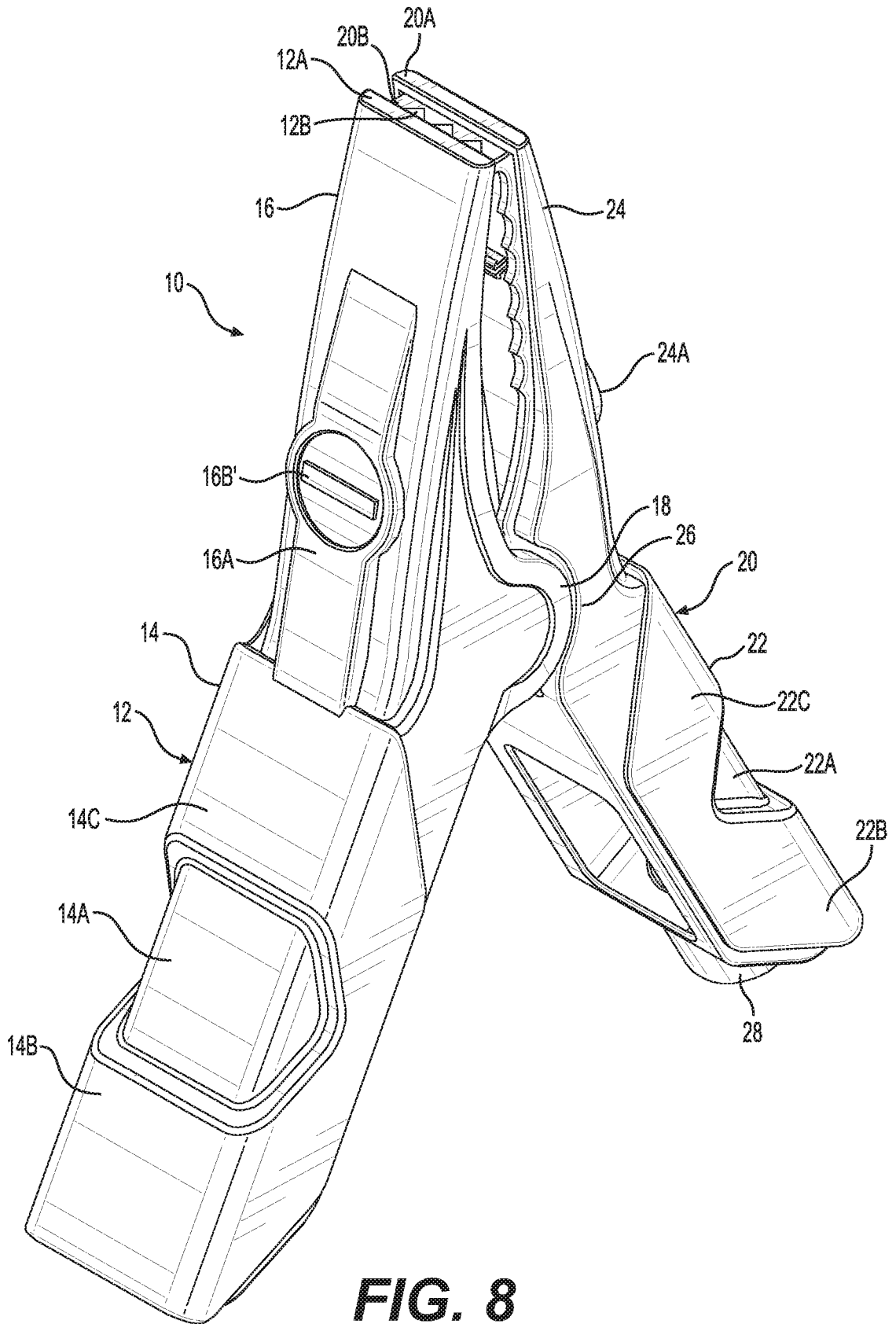

FIG. 7



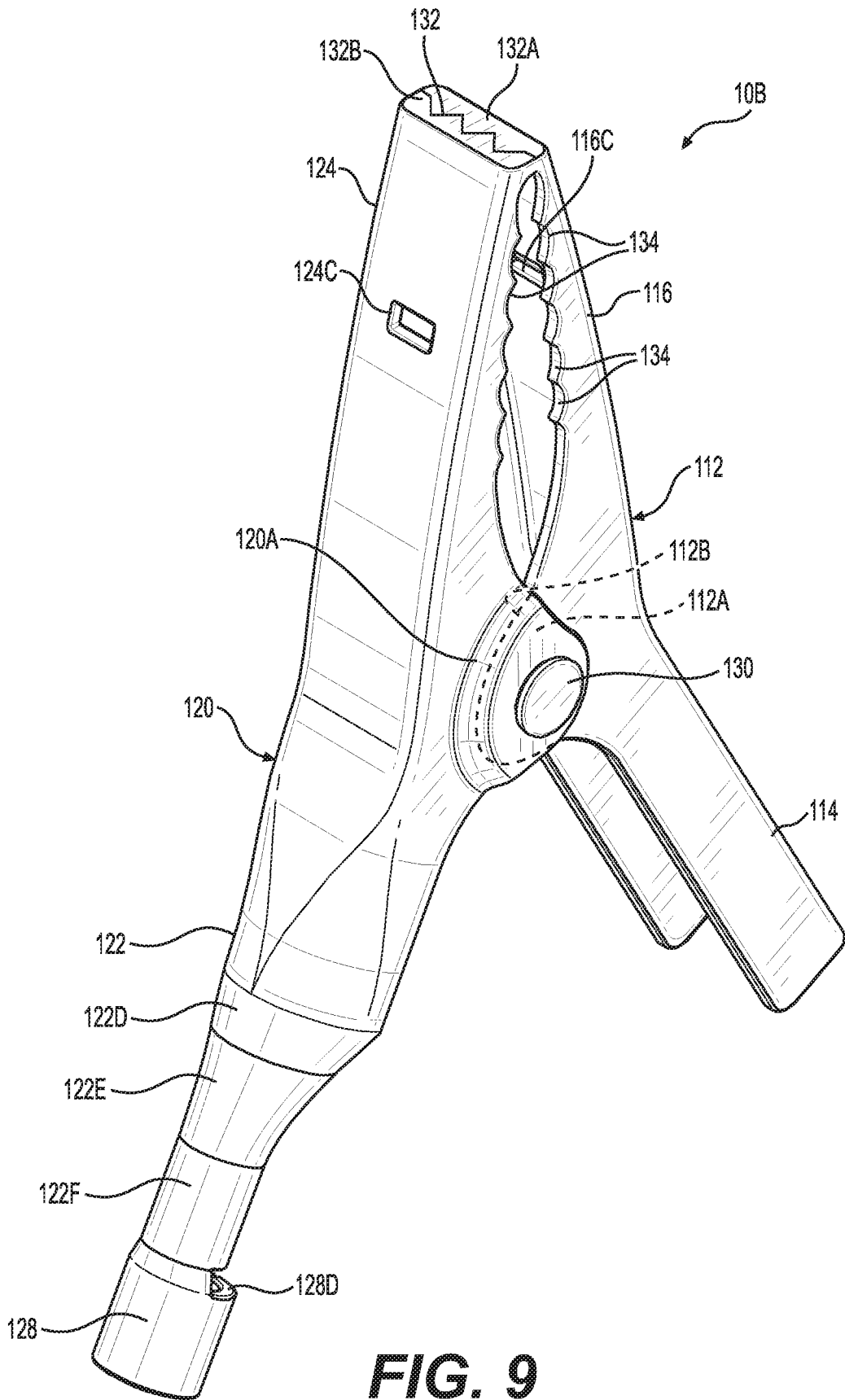

FIG. 9

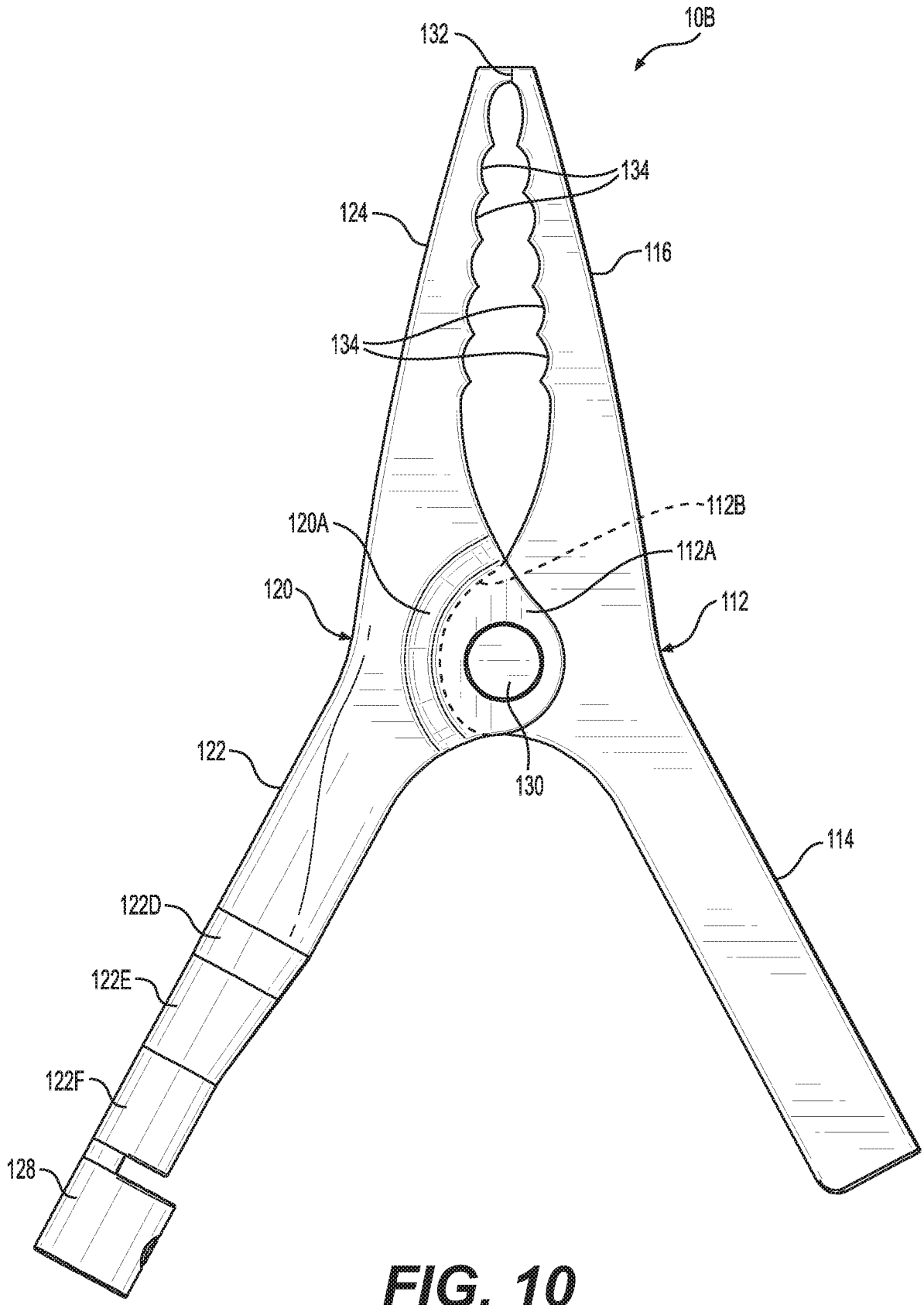

FIG. 10

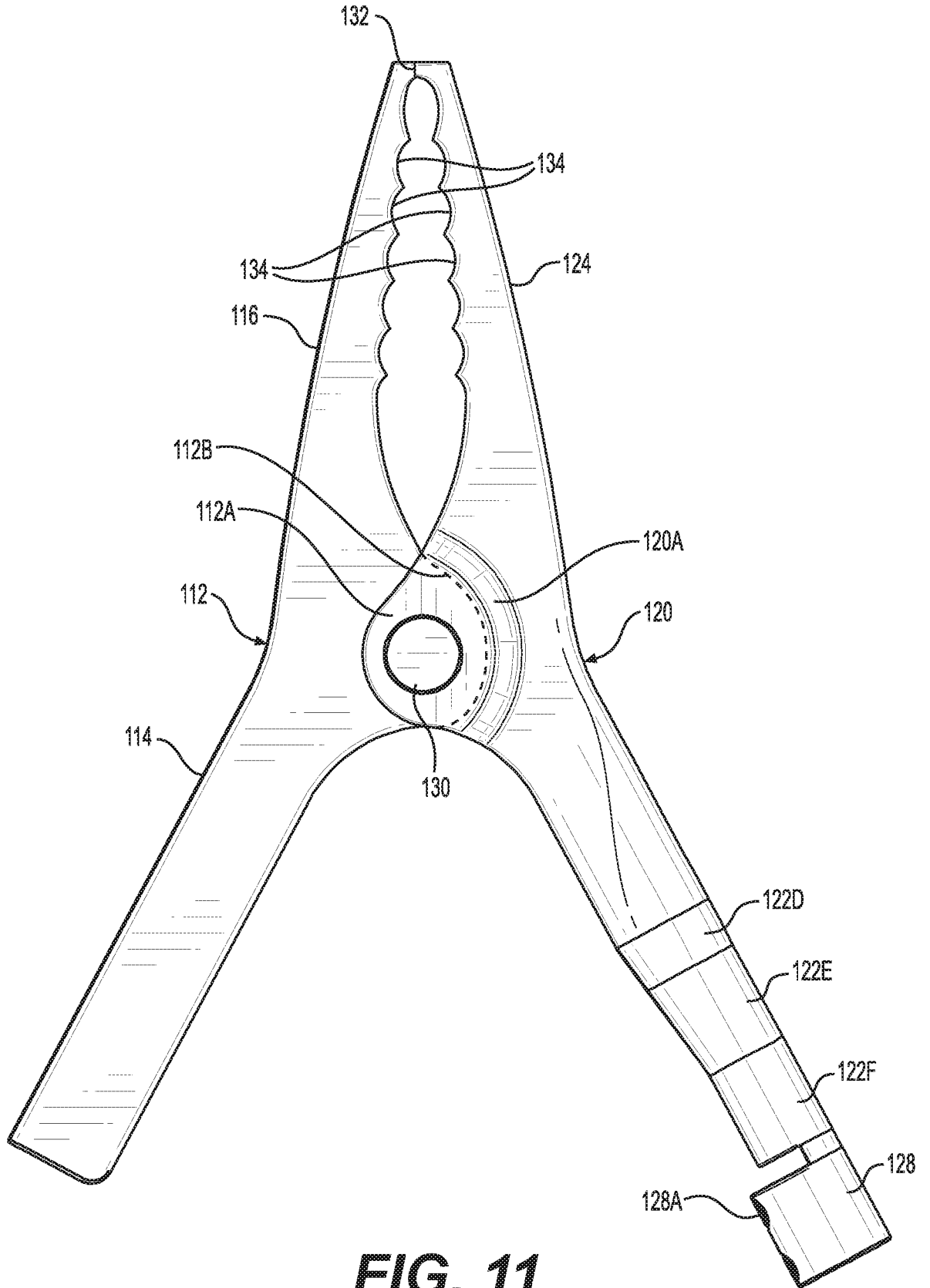

FIG. 11

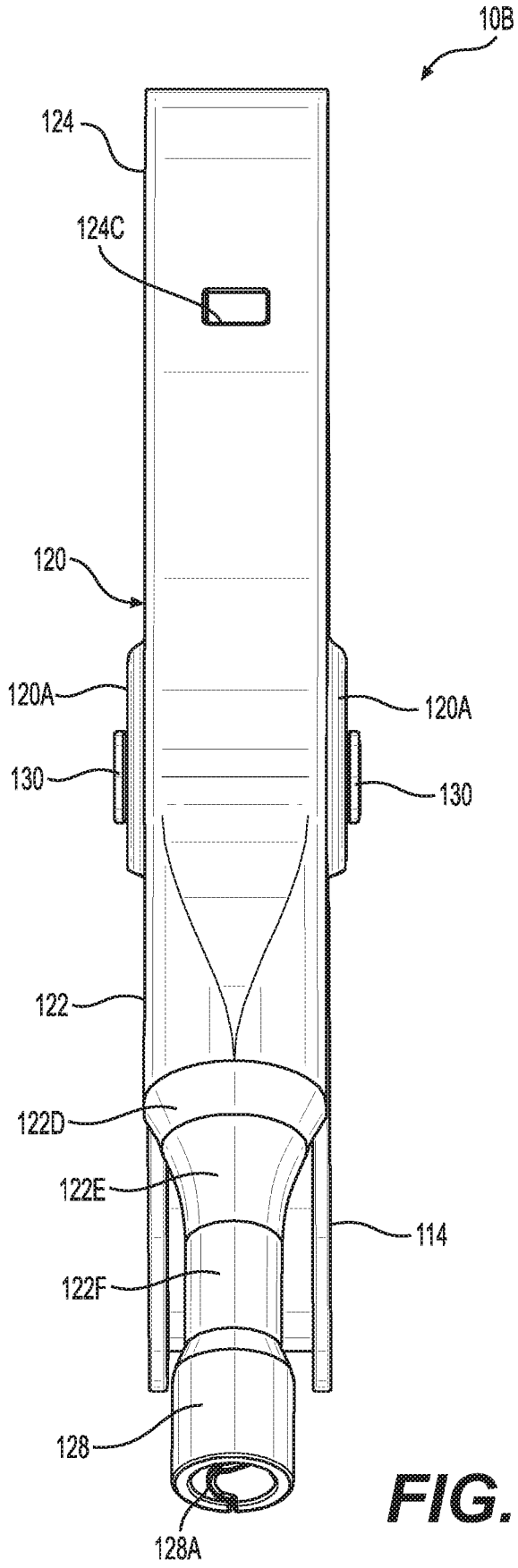

FIG. 12

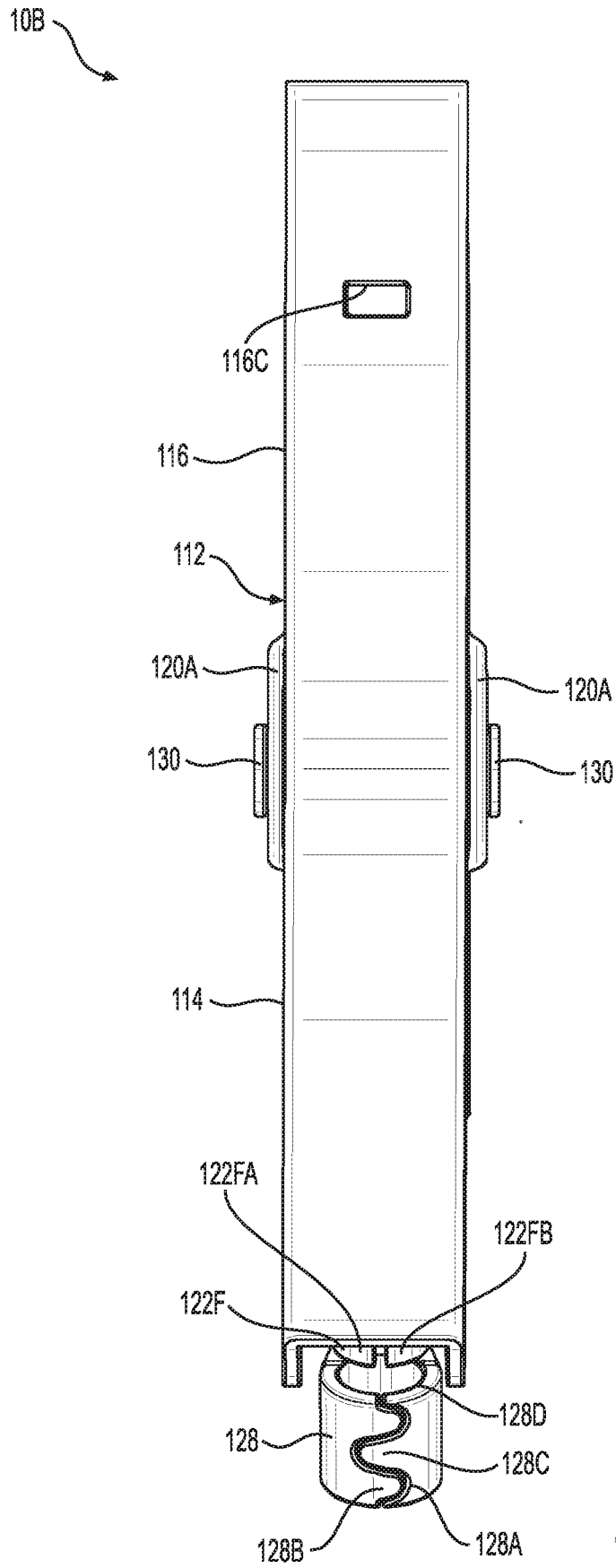

FIG. 13

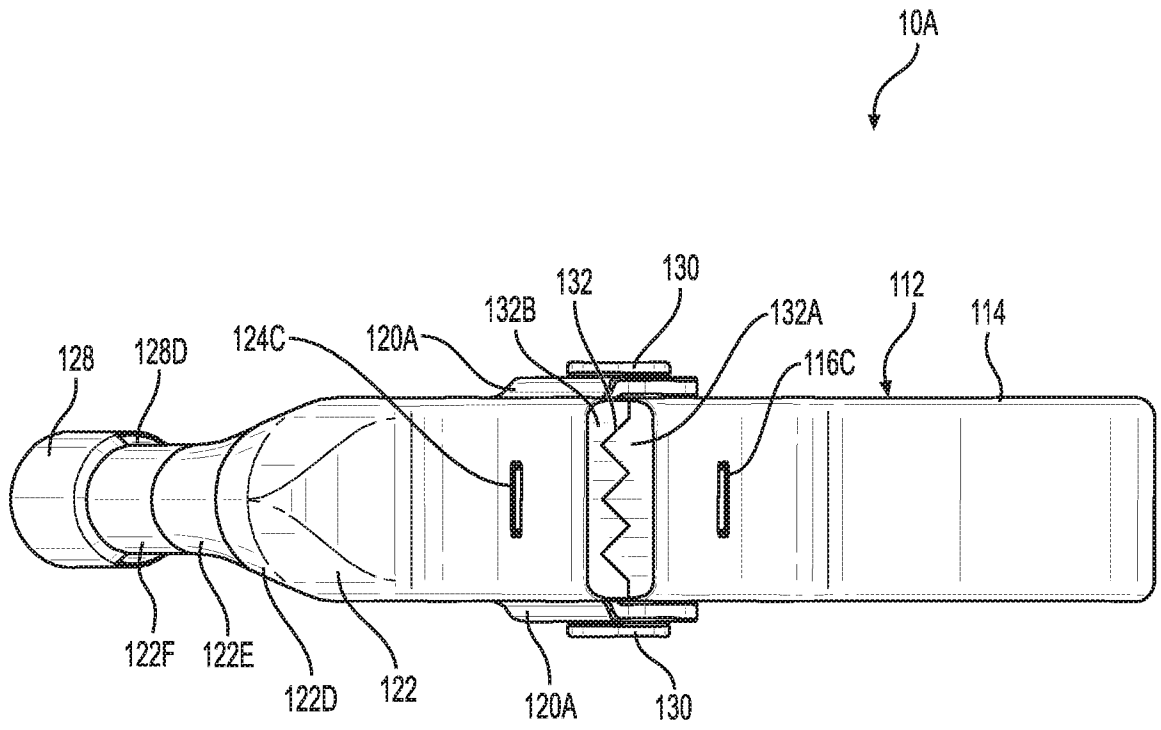

FIG. 14

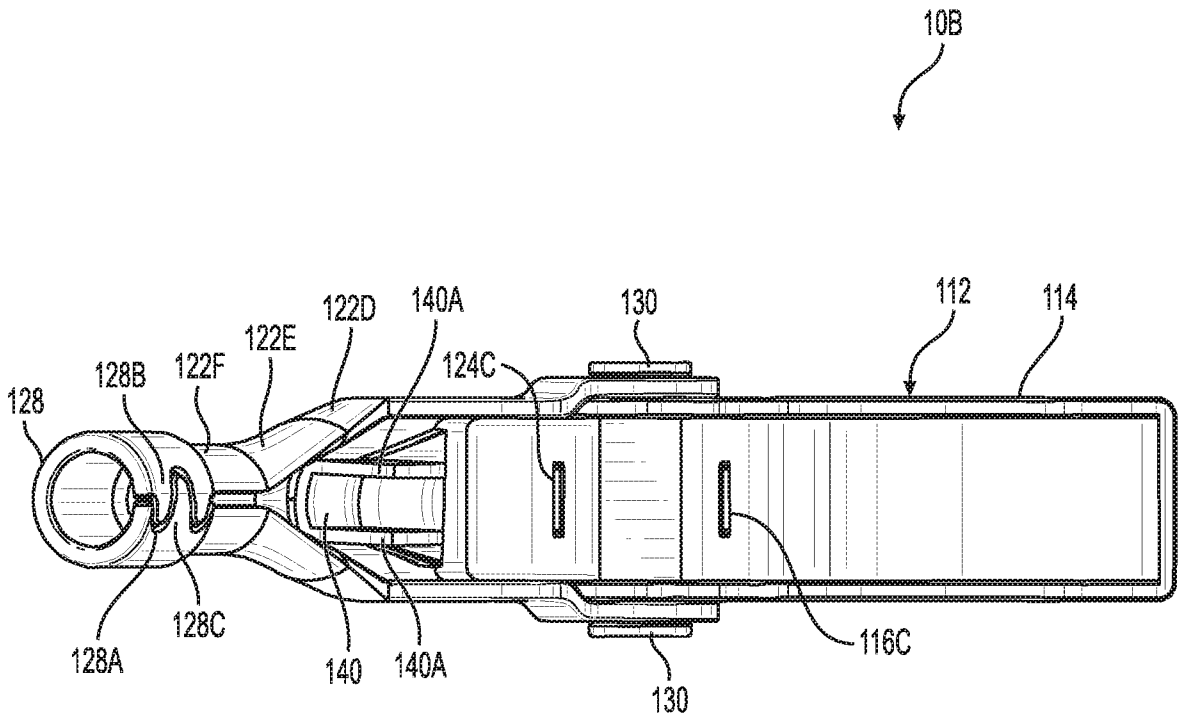

FIG. 15

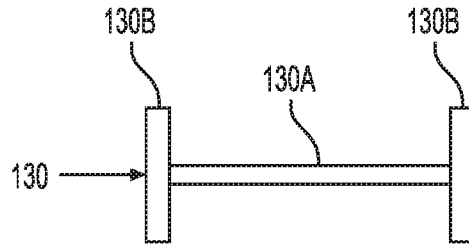

FIG. 16

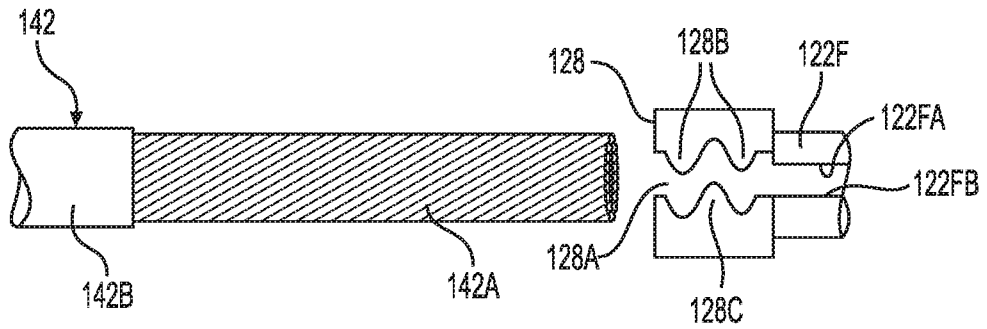

FIG. 17

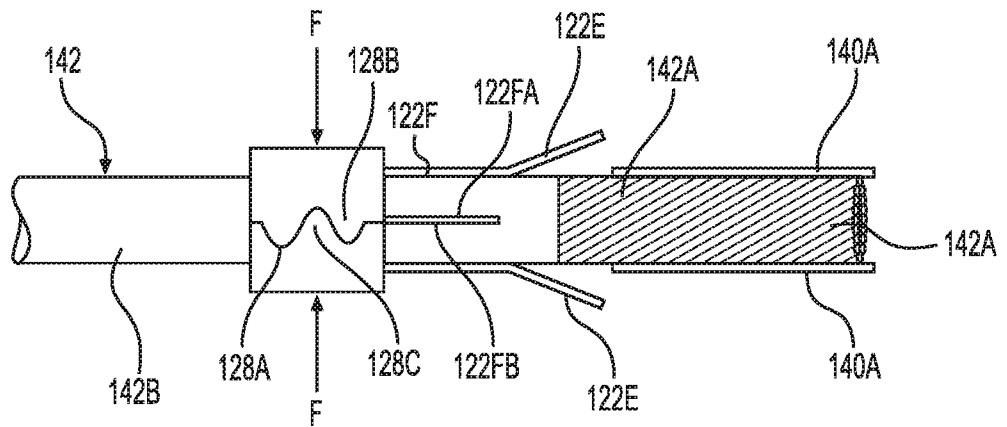

FIG. 18

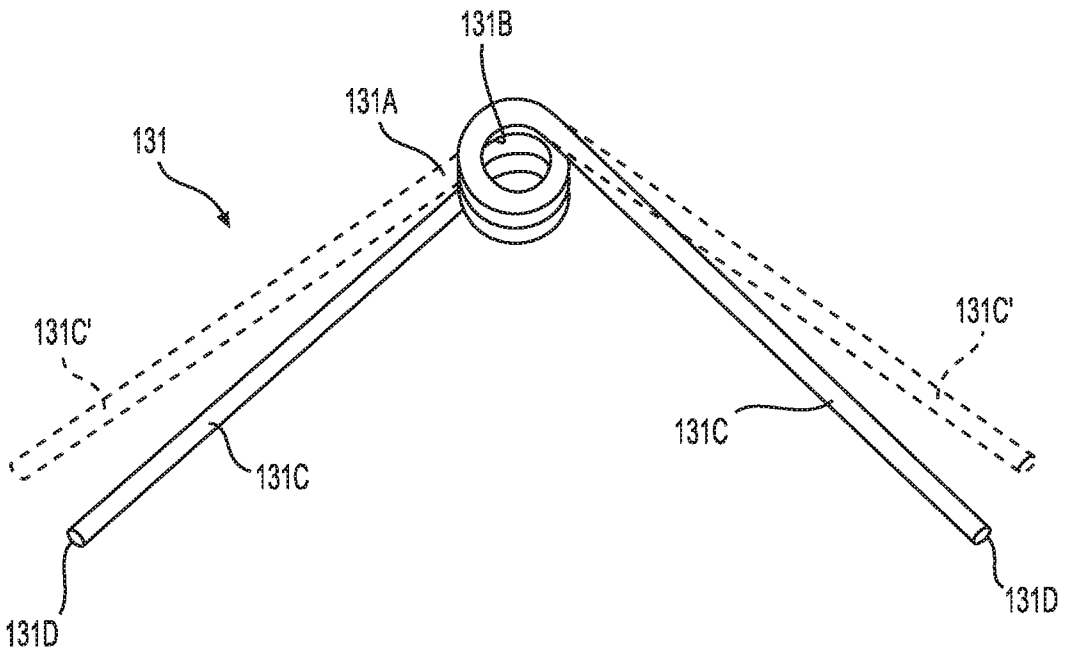

FIG. 19