



US 20090057315A1

(19) **United States**

(12) **Patent Application Publication**
Stringfield et al.

(10) **Pub. No.: US 2009/0057315 A1**

(43) **Pub. Date: Mar. 5, 2009**

(54) **CONTAINER END-CLOSURE INTERLOCKS**

(22) Filed: **Aug. 27, 2007**

(76) Inventors: **Lisa P. Stringfield**, Los Alamos,
NM (US); **Randal W. Stringfield**,
Los Alamos, NM (US)

Publication Classification

(51) **Int. Cl.**
B65D 17/34 (2006.01)

(52) **U.S. Cl.** **220/273**; 206/219; 239/10

Correspondence Address:
PEACOCK MYERS, P.C.
201 THIRD STREET, N.W., SUITE 1340
ALBUQUERQUE, NM 87102 (US)

(57) **ABSTRACT**

An interlocking container end closure which permits a plurality of containers to be joined together and the contents thereof mixed.

(21) Appl. No.: **11/845,306**

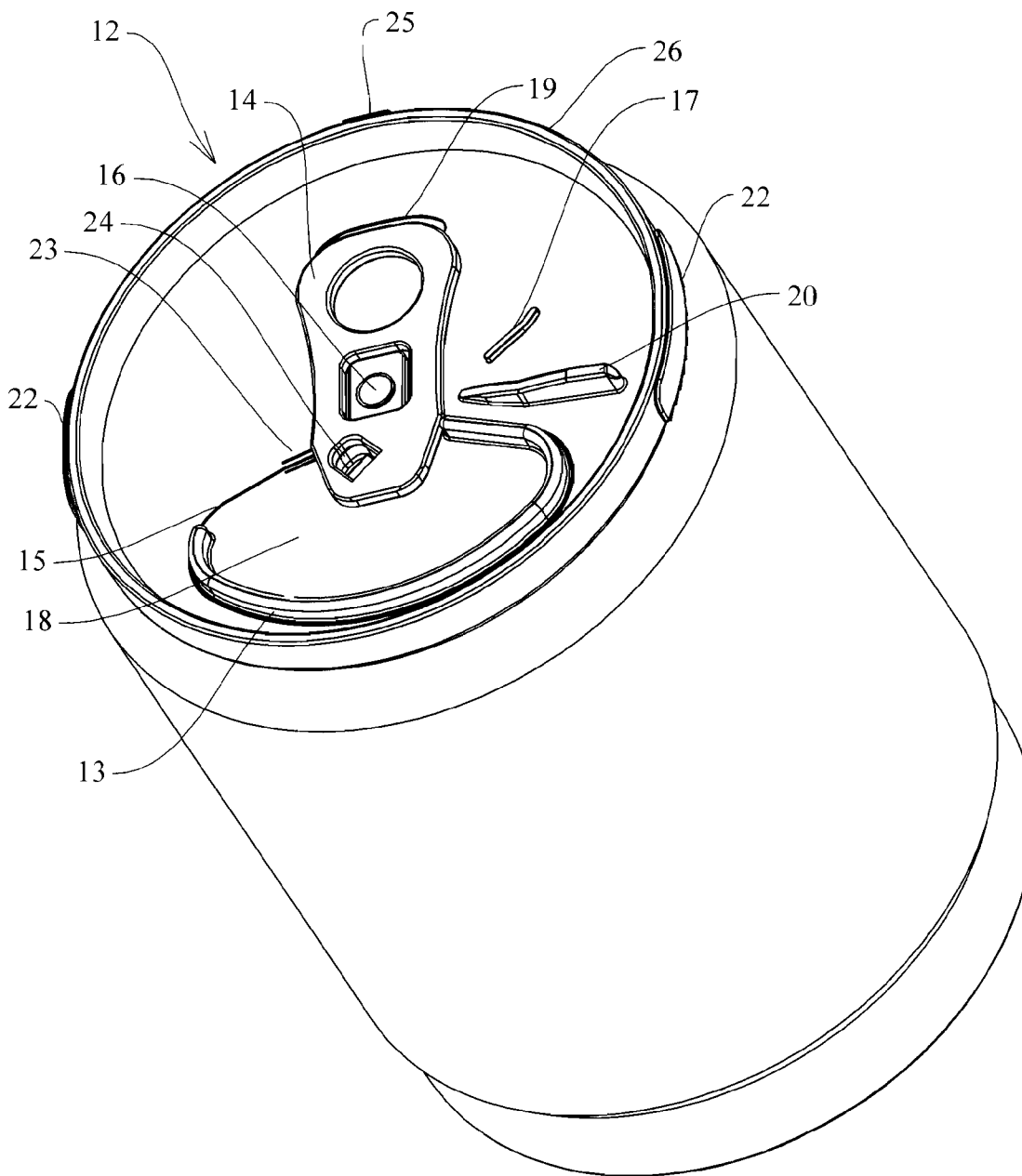

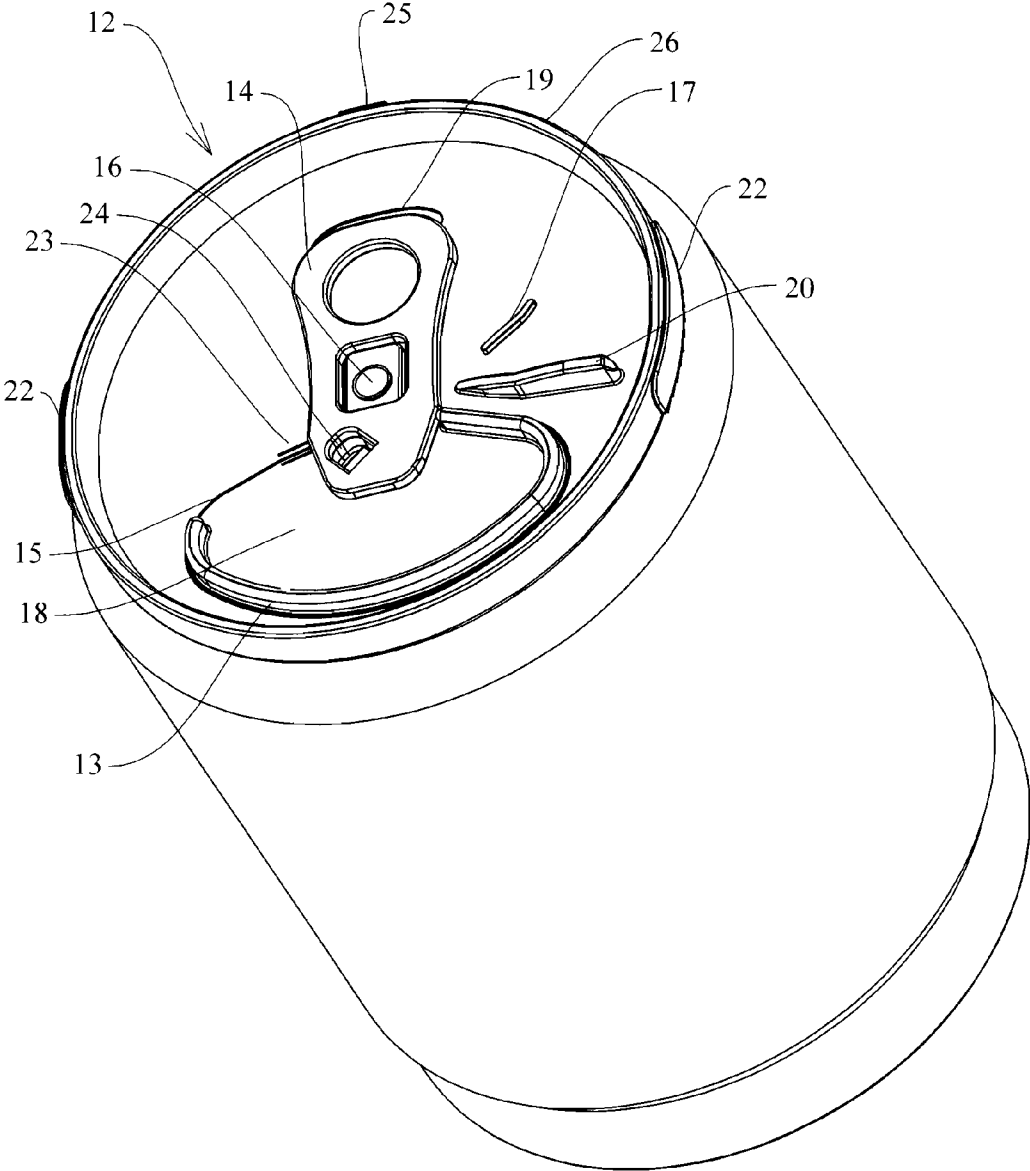

FIG. 1

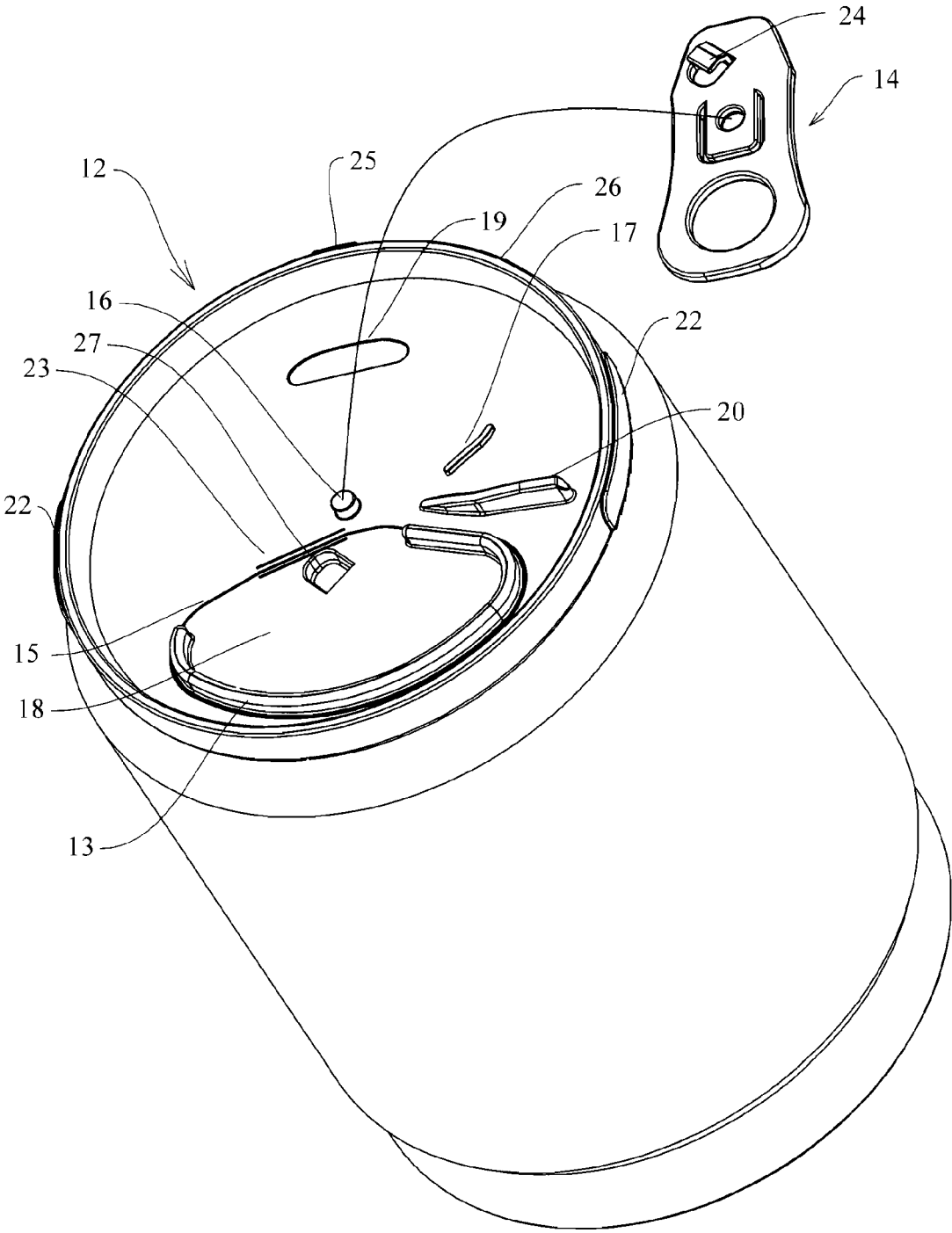

FIG. 2

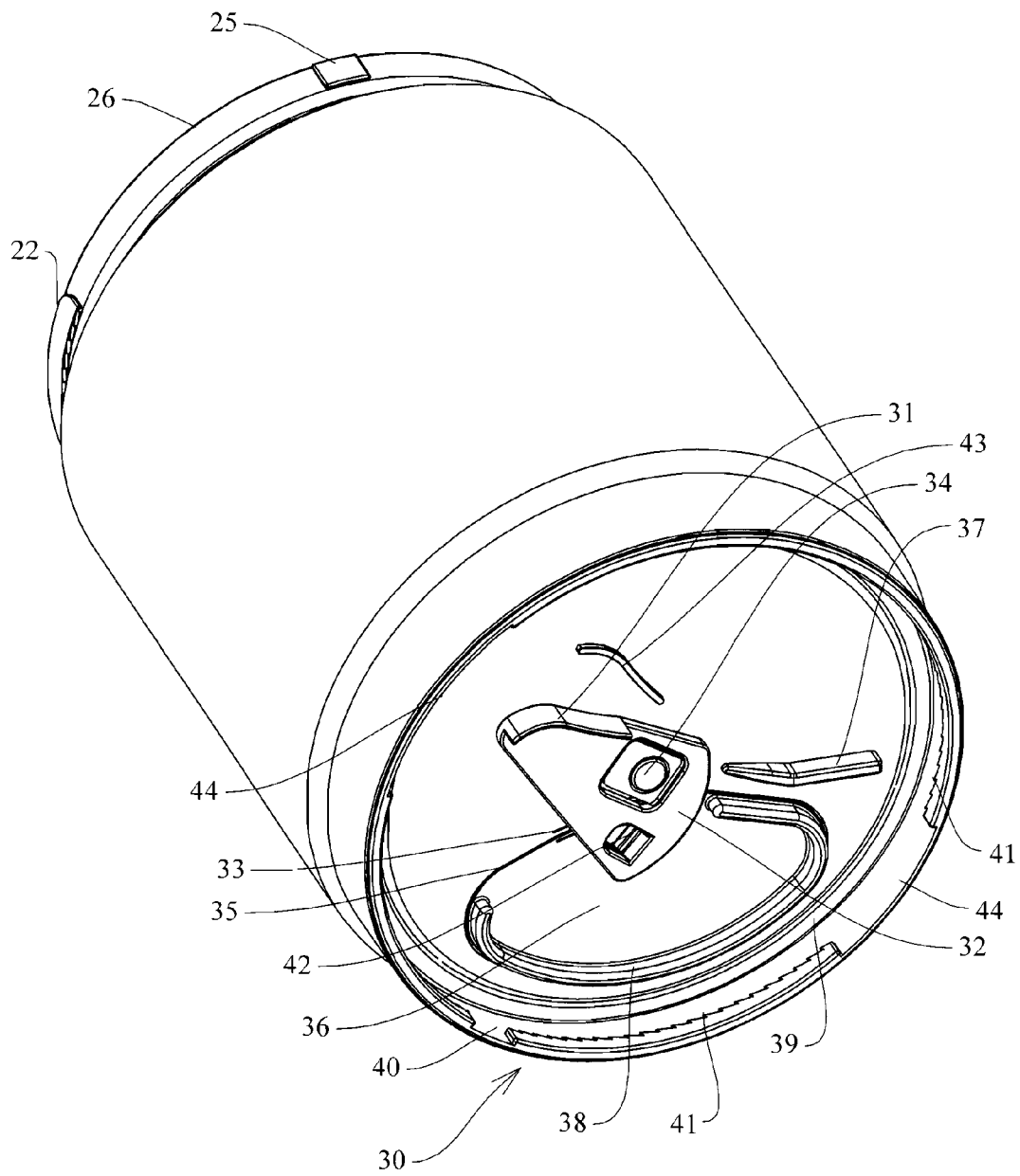

FIG. 3

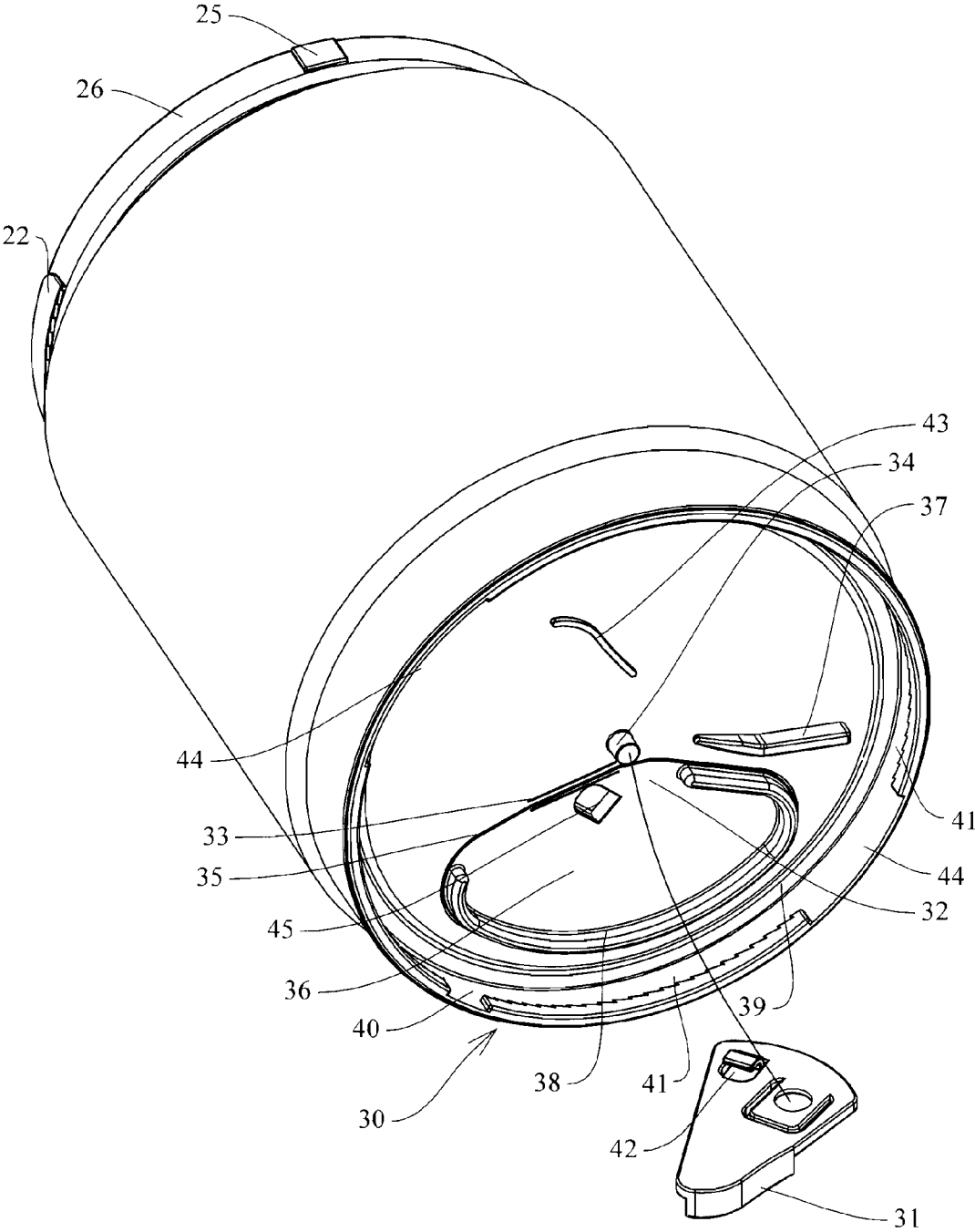

FIG. 4

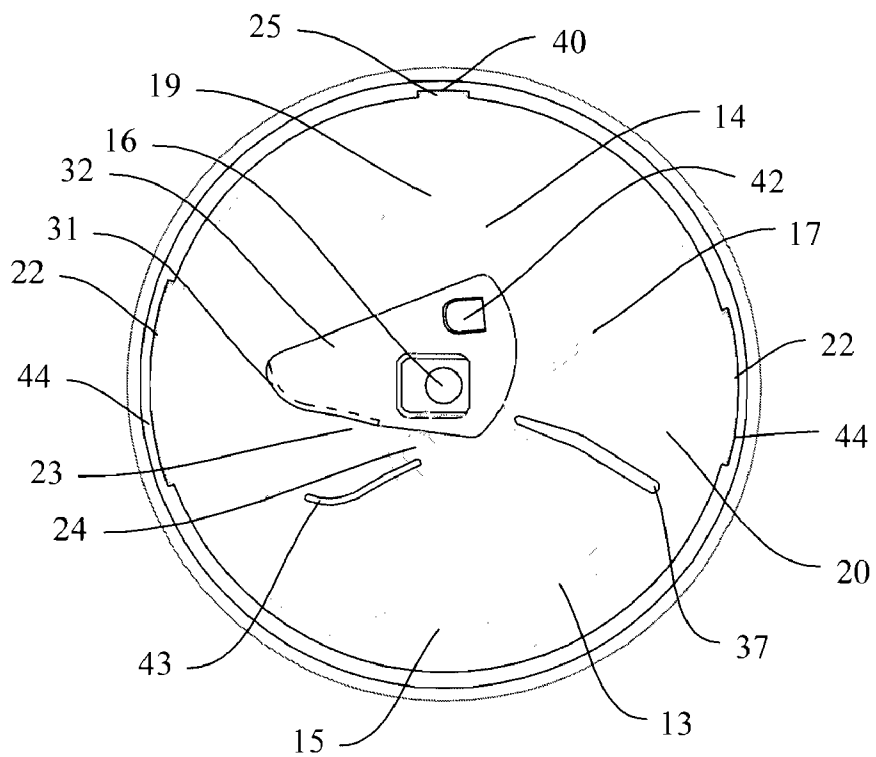

FIG. 5

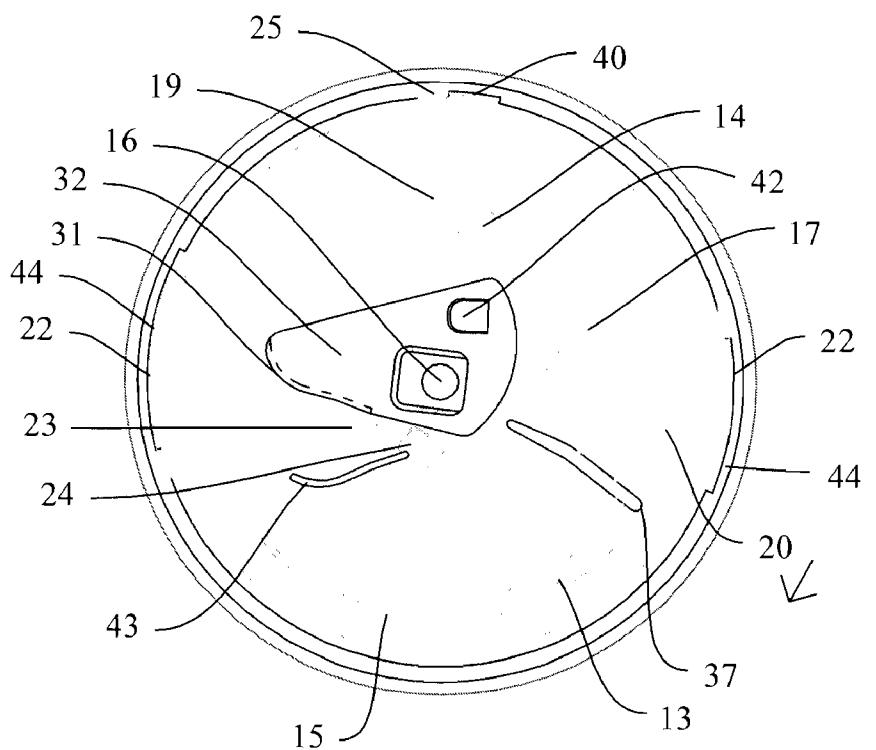

FIG. 6

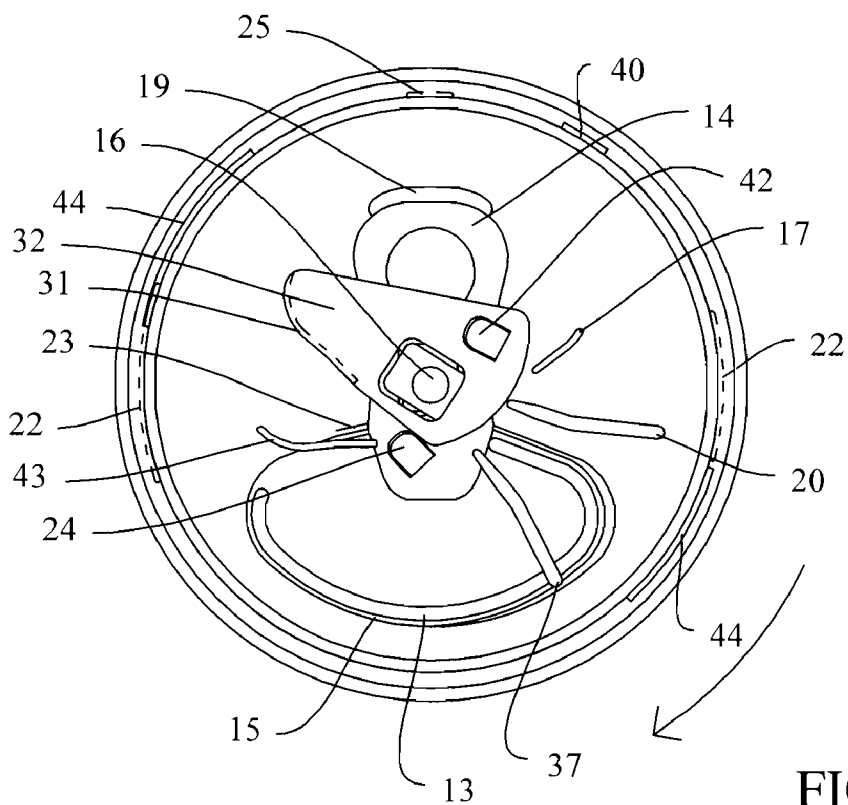

FIG. 7

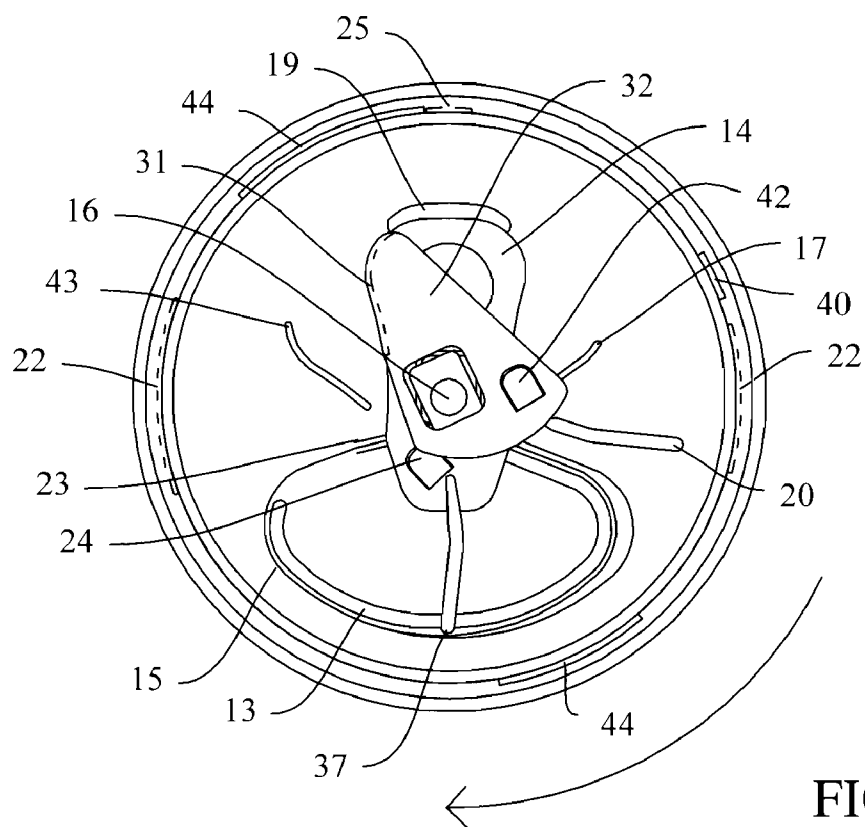

FIG. 8

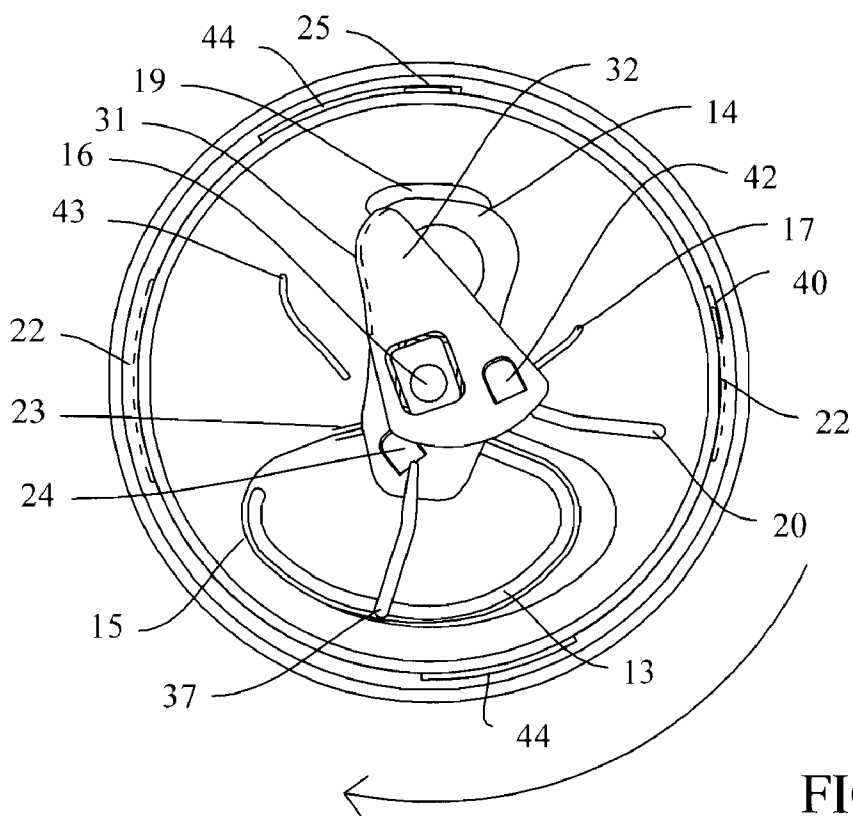

FIG. 9

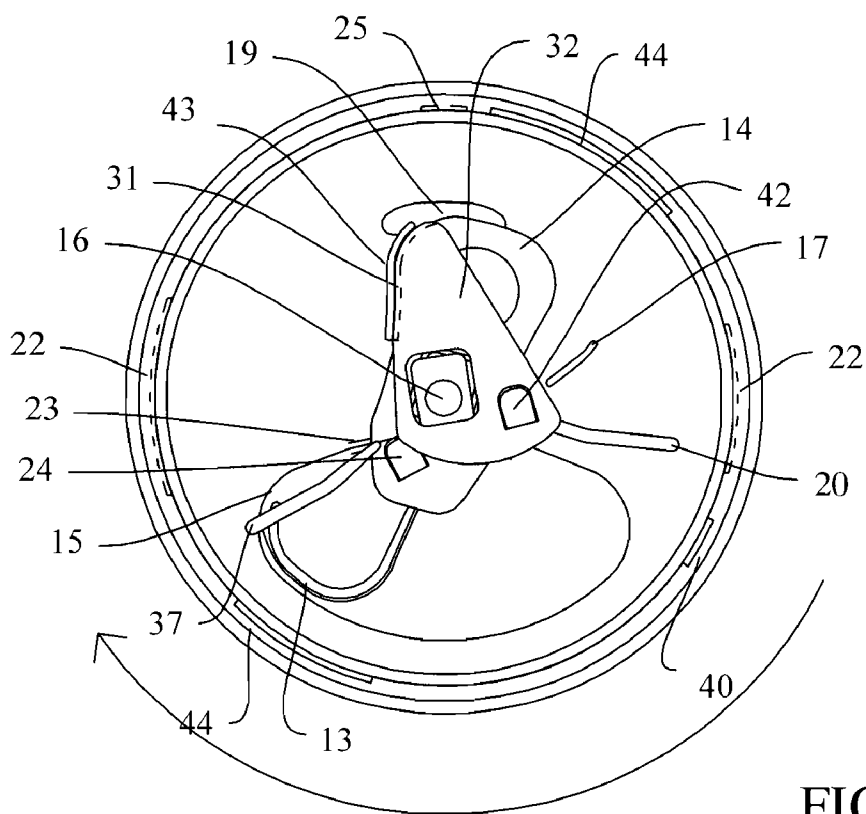

FIG. 10

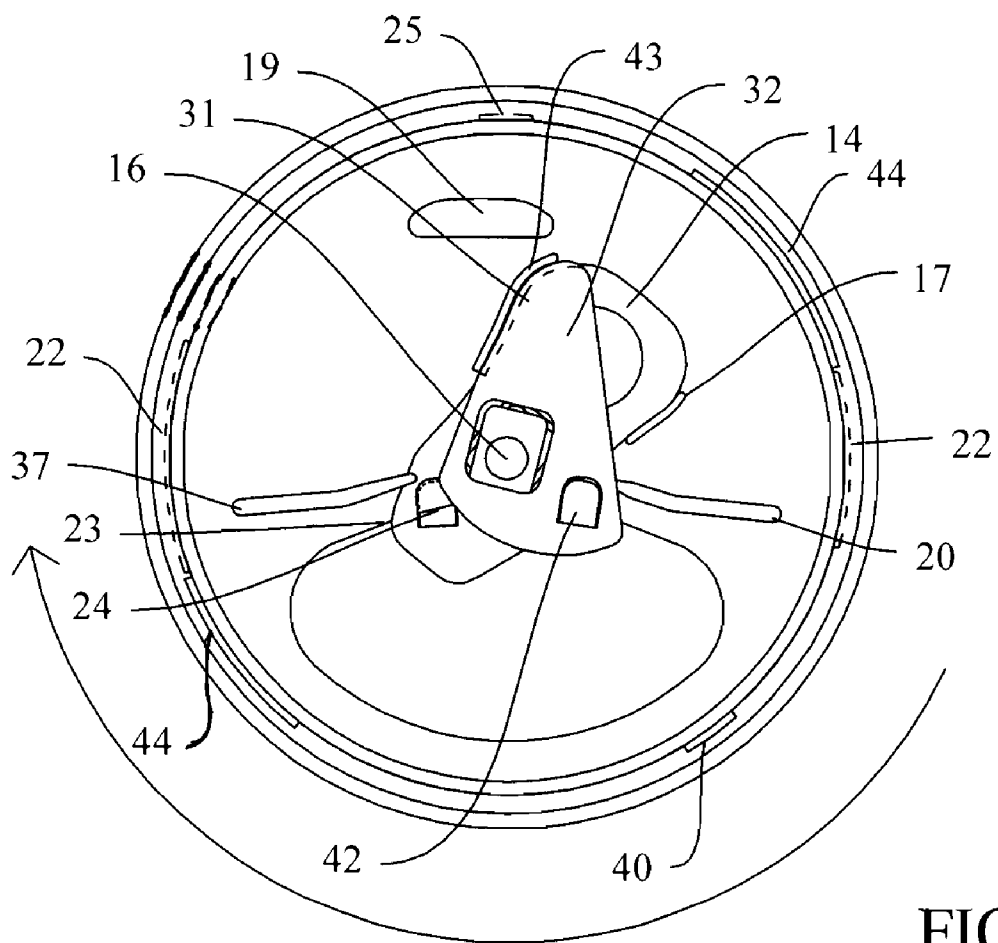

FIG. 11

CONTAINER END-CLOSURE INTERLOCKS

CROSS-REFERENCE TO RELATED APPLICATIONS

[0001] Not Applicable

FEDERALLY SPONSORED RESEARCH

[0002] Not Applicable

SEQUENCE LISTING OR PROGRAM

[0003] Not Applicable

BACKGROUND OF THE INVENTION

[0004] 1. Field Of The Invention (Technical Field)

[0005] This invention relates to a container design, and more specifically to container end closures.

[0006] 2. Background Art

[0007] Containers equipped with “end closures” (or end closure containers) can be used to store materials in a variety of forms, but have historically been used on metallic containers to contain liquids such as soft drinks and other consumable liquids. These containers are generally comprised of materials such as aluminum and are interconnected to a beverage single “end closure” after being filled. The end closure is typically sealingly interconnected to an upper end of the beverage container by “double seaming” or other manners well known in the art. For these types of containers, the container is opened for consumption using an “ecology tab,” or “stay-on tab” which is typically interconnected to the end. This stay-on tab allows the consumer to open the top end of the container to facilitate dispensing of the container contents.

[0008] Container opening devices, including frangible seals and pull tabs are generally known in the art. Known pull tabs and frangible seals typically remain attached to the container after opening. U.S. Pat. Nos. 6,412,526 and 6,415,940, describe known divided containers. More recently, manufacturers have started using Large Opening End closures (LOEs), which increase the surface area of the tear panel for enhanced flow capability. This LOE has allowed for easier use after opening the container.

[0009] Product manufacturers have historically utilized end closure containers to dispense the contents of a single container. As such, manufacturers have only needed to employ a container design that incorporates a single end closure. The contents of these containers have always been at the discretion of the manufacturer, and the product options available to the consumer when purchasing a single container have always been limited to those provided by the manufacturer. Due to the limitations of existing container designs, consumers cannot currently create their own mixture without first dispensing the products from their original containers. As such, creating a mixture from two or more containers requires the use of additional equipment (secondary containers, mixers, etc.), a stable work surface, and a steady hand. This task is difficult when it is performed while in transit or when there is limited time or space. Such are the constraints often posed when performing everyday tasks such as driving a car, biking, walking, etc. Therefore, there is a need for a new container design that allows the consumer to easily and efficiently create a mixed product without additional equipment and while on-the-go.

[0010] Thus, there is an industry need for a container design that will facilitate the interconnection of two or more containers without spillage or leakage, for the purpose of holding, mixing, and dispensing the container contents. These new end closures preferably have ease of use, preferably function for single and multiple interconnected containers, and preferably have the capability to be constructed of disposable or recyclable materials, as required. As described herein, the following invention addresses the aforementioned problems and design as described above.

BRIEF SUMMARY OF THE INVENTION

[0011] An embodiment of the present invention relates to a mixing apparatus that includes first and second containers having first and second ends, an engagement interface formable between a first and second end of the containers where the first and second containers are openable by a rotational force at the engagement interface. The mixing apparatus may include a locking mechanism, where the containers are locked by counter-rotation of the first and second containers. The mixing apparatus can also include an alignment mechanism. The engagement interface can include a seal, at least one tab, at least one hook, at least one catch, at least one scored panel, and at least one fastener.

[0012] An embodiment of the present invention relates to an openable container which includes an opening mechanism, the container openable from a rotational force applied to the mechanism and the container openable from a cantilever force. The opening mechanism may also have a tab, at least partially movable opening cover with a recess disposed in the cover, a hinge and/or a stop. The opening mechanism may further include a first tab comprising a first hook that is engagable with a first scored panel, the tab attached to the opening mechanism with a fastener, a locking mechanism, a seal, an aligning mechanism where the aligning mechanism has an alignment key, at least one slot and at least one band that aligns with the slot, a second tab and a ridge disposed at least partially around the perimeter of the first scored panel and second scored panel.

[0013] An embodiment of the present invention relates to a method for mixing two or more substances by providing two or more containers, the containers having first and second ends, engaging at least two of the containers at an interface, the interface formed from at least a first end of one of the containers and a second end of another of the containers, opening the engaged containers at or near the interface by the application of a counter-rotational force between the containers and mixing at least a portion of the contents of the engaged containers. The method for mixing also optionally includes forming an at least substantially water-tight seal between the engaged containers and/or locking the engaged containers together with a locking mechanism. There may also be an aligning mechanism for engaging the at least two containers.

[0014] An embodiment of the present invention is the integration of two end closure interlock assemblies into one container—one interlock assembly located on the top end of the container, and the other located on the bottom end of the container. These interlocks are used to align and/or seal two stacked containers, and to create a fully contained opening between the containers to promote mixing of the container contents. As such, one aspect of the present invention preferably provides a container top interlock assembly that incorporates a stay-on tab; this interlock assembly can be used either for opening a single container, or for engaging the

bottom interlock assembly on an adjacently stacked container. It is another aspect of the present invention to provide a bottom interlock assembly that can be engaged by the top interlock assembly of an adjacent, stacked container. It is yet another aspect of the present invention to create these interlocks such that the end closures do not prematurely leak or rupture when not engaged.

[0015] Accordingly, several objects and advantages of embodiments of the present invention preferably include:

[0016] a. Providing a top interlock assembly (TIA) on the top end closure, and a bottom interlock assembly (BIA) on a new bottom end closure which are integrated into a single container such that they facilitate contained mixing of the contents of two or more stacked containers;

[0017] b. Providing a stay-on tab on the container's top end closure to facilitate opening of a container in the traditional manner;

[0018] c. Providing an alignment key on the said TIA and an alignment key receiver on the said BIA to ensure proper alignment of two containers, and to ensure that the container openings remain aligned (one on top of the other) at the completion of the coupling process;

[0019] d. Providing catch bands on the TIA, catch band rings on the BIA, and a gasket on the BIA to facilitate irreversible coupling and sealing of two or more containers, and to create a leak proof seal at the interface;

[0020] e. Providing a TIA tear panel ridge that can be engaged by a BIA wiper simultaneous with coupling of the containers;

[0021] f. Providing a TIA tear panel hinge and TIA tear panel hook that can open the TIA tear panel simultaneous with coupling of the containers;

[0022] g. Providing a BIA tear panel ridge that can be engaged by a TIA component simultaneous with coupling of the containers;

[0023] h. Providing a BIA tear panel hinge and BIA pivot tab hook that can open the BIA tear panel simultaneous with coupling of the containers; and

[0024] i. Providing a pivot tab catch on the pivot tab that can be engaged by a stay-on tab for rotating the pivot tab simultaneous with coupling of the containers.

[0025] j. Providing a BIA pivot tab stop and a TIA stay-on tab stop to prevent over-rotation of the adjoined containers once the openings are fully aligned;

[0026] Still further objects and advantages will become apparent from a consideration of the ensuing description and drawings.

[0027] Thus, the consumer can easily and conveniently join together two or more stacked containers, without damaging either container, and without spilling/leakage of the container contents, to promote mixing and dispensing of the container contents. This effort is limited to aligning the containers, coupling the containers by engaging the catch band and catch band rings, creating a sealed opening between the containers, and engaging the stay-on pull tab on the TIA to open the container. The present invention allows for minimal consumer education or effort in order to use this invention.

BRIEF DESCRIPTION OF THE SEVERAL VIEWS OF THE DRAWINGS

[0028] The accompanying drawings, which are incorporated into and form a part of the specification, illustrate one or more embodiments of the present invention and, together with the description, serve to explain the principles of the

invention. The drawings are only for the purpose of illustrating one or more preferred embodiments of the invention and are not to be construed as limiting the invention. In the drawings:

[0029] FIG. 1 is a top isometric view of an embodiment of the TIA and the components related thereto;

[0030] FIG. 2 is an exploded top isometric view of an embodiment of the TIA and the components related thereto;

[0031] FIG. 3 is a top isometric view of an embodiment of the BIA and the components related thereto;

[0032] FIG. 4 is an exploded top isometric view of an embodiment of the BIA and the components related thereto;

[0033] FIGS. 5 through 11 are top views of an embodiment of the BIA as it is overlaid onto the TIA during the interlocking and opening sequence. The starting sequence in FIG. 5 illustrates the initial alignment at the beginning of the interlock sequence. FIG. 11 illustrates the ending alignment when the assemblies are fully interlocked and the containers are fully opened. The arrows illustrate an amount of rotation that is preferably applied to the upper and/or lower container during the sequence.

DETAILED DESCRIPTION OF THE INVENTION

[0034] To assist in the understanding of the present invention, the following is a list of the components and associated numbering showing in the drawings.

#	Component
12	Top integrated assembly (TIA)
13	TIA tear panel ridge
14	TIA stay-on tab
15	TIA tear panel score
16	TIA fastener
17	TIA stay-on tab stop
18	TIA tear panel
19	Finger well
20	TIA wiper
22	Catch band
23	TIA tear panel hinge
24	Stay-on tab hook
25	Alignment key
26	TIA rim
27	TIA tear panel well
30	Bottom integrated assembly (BIA)
31	Pivot tab catch
32	Pivot tab
33	BIA tear panel hinge
34	BIA fastener
35	BIA tear panel score
36	BIA tear panel
37	BIA wiper
38	BIA tear panel ridge
39	Gasket
40	Alignment key receiver
41	Catch band ring
42	BIA pivot tab hook
43	BIA pivot tab stop
44	Catch band slots
45	BIA tear panel well

[0035] Referring now to the drawings, FIG. 1 illustrates an embodiment of the present invention, wherein TIA 12 is provided and adapted for coupling with BIA 30 (FIG. 2).

[0036] Referring to the Figs., wherein like numerals indicate like or corresponding parts throughout the several views, a preferred embodiment of the container connector, sealer, and opener of the present invention is illustrated in FIGS. 1-4.

As illustrated in FIG. 1, TIA 12 is preferably comprised of multiple components described as follows. TIA stay-on tab 14 is connected via TIA fastener 16 to a center portion of TIA 12 for dispensing the container contents in the traditional manner using finger well 19, or in conjunction with a connected BIA 30. When opening the container in the traditional manner, TIA stay-on tab 14 is preferably lifted upward, and a nose of TIA stay-on tab 14 is driven downward into TIA tear panel 18. As force is continually applied, TIA tear panel 18 is torn away from the center panel by means of TIA tear panel score 15. TIA tear panel 18 begins deflecting downward and into the beverage container as the tear moves clockwise, as viewed from an outer surface thereof. Once TIA tear panel 18 is pushed downward from the center panel, TIA stay-on tab 14 may be pushed downward, and the beverage consumed in the traditional manner while TIA tear panel 18 remains attached at TIA tear panel hinge 23.

[0037] Other TIA 12 component parts are incorporated to facilitate coupling, sealing, and opening TIA 12 when connected to BIA 30. These components include stay-on tab hook 24, which is preferably disposed near a nose of TIA stay-on tab 14. TIA tear panel ridge 13 is preferably disposed near the rim of TIA tear panel 18. TIA wiper 20 is preferably disposed between TIA tear panel ridge 13, and TIA stay-on tab stop 17. The perimeter of the TIA includes a segmented catch band 22 and an alignment key 25. FIG. 2 is an isometric view illustrating TIA 12 with TIA stay-on tab 14 shown separated from the TIA to provide more detail for stay-on tab hook 24 and associated TIA tear panel well 27.

[0038] BIA 30 is not used or engaged unless it is coupled with TIA 12. BIA 30, as illustrated in FIG. 3, is preferably comprised of multiple components described as follows. Pivot tab 32 connected via BIA fastener 34 to a center portion of BIA 30 to facilitate opening of BIA 30 when coupled with TIA 12. This tab preferably does not open the container in the traditional manner. Rather, when a rotation force is applied to the coupled containers, this force engages TIA wiper 20, BIA wiper 37, TIA tear panel ridge 13, and BIA tear panel ridge 38, which then facilitates simultaneous opening of BIA tear panel 36 and TIA tear panel 18. A seal is preferably created between the containers by means of gasket 39.

[0039] BIA tear panel 36 is preferably torn away from center panel by means of BIA tear panel score 35. BIA tear panel 36 begins deflecting into the beverage container as TIA wiper 20 moves clockwise across BIA tear panel ridge 38 as viewed from the outer surface thereof. During this process, TIA stay-on tab 14 engages pivot tab catch 31, and initiates rotation of pivot tab 32, which causes BIA pivot tab hook 42 to fold BIA tear panel 36 downward into the container at BIA tear panel hinge 33. BIA wiper 37 is preferably mounted between BIA tear panel ridge 38, and BIA pivot tab stop 43. The perimeter of the BIA preferably includes alignment key receiver 40 and catch band ring 41. FIG. 4 provides an isometric view of BIA 30 with the pivot tab 32 shown separated from BIA 30 to provide more detail on BIA pivot tab hook 42 and associated BIA tear panel well 45.

Operation—FIGS. 5 Through 11

[0040] FIGS. 5 through 11 are top plan views of BIA 30 as it is overlaid onto TIA 12 during the interlocking and opening sequence. Only the interfacing TIA 12 and BIA 30 are illustrated to show how these assemblies relate and engage each other during the opening sequence. Note that for illustration purposes, some of BIA 30 components (specifically, BIA tear

panel 36, BIA tear panel ridge 38, BIA tear panel score 35, and BIA tear panel hinge 33) are excluded from FIGS. 5 through 11. Effectively, FIGS. 5 through 11 illustrate the interaction of BIA 30 components with TIA 12 components necessary to facilitate opening of TIA tear panel 18. The opening sequence also results in the simultaneous opening of BIA tear panel 36; however, this action is not illustrated. The arrows on FIGS. 6 through 11 are representative of the rotation applied to BIA 30 in order to initiate coupling of the two containers.

[0041] The starting sequence in FIG. 5 shows the initial alignment at the beginning of the coupling and opening sequence. Two containers are brought together by inserting alignment key 25 into alignment key receiver 40, which results in insertion of catch bands 22 into catch band slots 44. At this point, TIA rim 26 is seated against gasket 39.

[0042] On FIG. 6, catch bands 22 have moved under the catch band ring 41. The catch bands and catch band rings feature a saw-tooth profile which, when mated, allow one-way rotation of the coupled containers and prevent inadvertent reversing of the coupling. This design also ensures a secure seating of TIA rim 26 against the gasket 39. In FIG. 6, BIA wiper 37 has moved clockwise over TIA tear panel ridge 13, causing TIA tear panel score 15 to break. Pivot tab 32 and associated components (specifically BIA pivot tab stop 43, pivot tab catch 31, and BIA pivot tab hook 42) have also rotated with BIA 30 according to an amount as illustrated by the arrow.

[0043] On FIG. 7, catch bands 22 and catch band ring 41 continue to engage. BIA wiper 37 continues to move over TIA tear panel ridge 13, causing further breakage along TIA tear panel score 15. Pivot tab 32 and associated components have also rotated with BIA 30 according to an amount as illustrated by the arrow.

[0044] On FIG. 8, catch bands 22 and catch band ring 41 continue to engage. BIA wiper 37 continues to move over TIA tear panel ridge 13, causing further breakage along TIA tear panel score 15. At this point, pivot tab catch 31 has mated with the left edge of TIA stay-on tab 14. From this point on in the opening sequence, pivot tab 32 and TIA stay-on tab 14 are preferably connected and move as a single unit. BIA pivot tab stop 43 has continued to rotate with BIA 30 according to an amount as illustrated by the arrow.

[0045] On FIG. 9, catch bands 22 and catch band ring 41 continue to engage. BIA wiper 37 continues to move over TIA tear panel ridge 13, causing further breakage along TIA tear panel score 15. At this point, mated pivot tab catch 31 and TIA stay-on tab 14 have rotated according to an amount as illustrated by the arrow. This rotation causes stay-on tab hook 24 to engage TIA tear panel 18 such that TIA tear panel 18 is pushed into the container along TIA tear panel hinge 23. BIA pivot tab stop 43 has continued to rotate with BIA 30 according to an amount as illustrated by the arrow.

[0046] On FIG. 10, catch bands 22 and catch band ring 41 continue to engage. BIA wiper 37 continues to move over TIA tear panel ridge 13, causing further breakage along TIA tear panel score 15. At this point, mated pivot tab catch 31 and TIA stay-on tab 14 have rotated according to an amount as illustrated by the arrow. This rotation causes stay-on tab hook 24 to fold TIA tear panel 18 into the container along TIA tear panel hinge 23. BIA pivot tab stop 43 has come in contact with the left edge of mated pivot tab catch 31 and TIA stay-on tab 14.

[0047] FIG. 11 shows the completion of the opening sequence. At this point, catch bands 22 and catch band ring 41 have fully engaged. Mated pivot tab 32 and TIA stay-on tab 14 have rotated according to an amount as illustrated by the

arrow. BIA wiper **37** has moved over TIA tear panel ridge **13**, causing complete breakage along TIA tear panel score **15**. Stay-on tab hook **24** has completely folded TIA tear panel **18** into the container along TIA tear panel hinge **23**. BIA pivot tab stop **43** and TIA stay-on tab stop **17** have prevented further rotation of the mated components, thereby ensuring that the container openings remain completely aligned.

[0048] Once the opening sequence has been completed per FIGS. **5** through **11**, the consumer can optionally manipulate the coupled containers to facilitate mixing of the container contents. Once the desired level of mixing is obtained, the container may be opened in the traditional manner by engaging TIA stay-on tab **14** as previously described.

[0049] From the description above, a number of advantages of TIA **12** and BIA **30** end closures become evident:

[0050] a. Consumers will have the ability to customize a beverage, snack, or other consumable or non-consumable product by coupling together two or more containers and mixing the container contents in a confined manner. TIA **12** and BIA **30** end closure designs also preferably prevent inadvertent reversal of this coupling.

[0051] b. Because there is no concern for spillage/leakage of the combined container contents, the consumer has the ability to perform the coupling, sealing, and mixing of these container contents while on-the-go or in places where mixing of two or more container contents without benefit of the present invention would otherwise be difficult.

[0052] c. Consumers have the ability to dispense the mixture created by coupling, sealing, and opening multiple stacked containers in the traditional manner. They are also able to dispense the contents of a single container in the tradition manner, if mixing of multiple containers is not desired.

[0053] d. Consumers have the ability to create an extensive number of container combinations to suit their specific purposes. Consumers can stack as many containers as desired, with as many combinations of container contents as desired.

[0054] e. The present invention allows for minimal consumer education or effort in order to use this invention.

[0055] Accordingly, in one embodiment of the present invention, the consumer can easily and conveniently join together two or more stacked containers, without damaging either container, and without spilling/leakage of the container contents, to promote mixing and dispensing of the container contents. This effort is limited to aligning the containers, coupling the containers by engaging catch bands **22** and catch band rings **41**, creating a sealed opening between the containers, and employing TIA stay-on tab **14** with BIA pivot tab **32** to open the containers. Furthermore, the present invention has the additional advantages in that:

[0056] It allows the consumer to mix the contents of two or more containers without initially dispensing the container contents;

[0057] It permits the consumer to customize a beverage, snack, or other consumable or non-consumable product while on-the-go, or in places where mixing of two or more container contents without benefit of the present invention would otherwise be impractical or difficult;

[0058] It allows the consumer to create an extensive number of container combinations to suit his/her tastes;

[0059] It allows the consumer to open the top-most container in the traditional manner, thereby minimizing the amount of education required to operate the present invention; and

[0060] It allows the consumer to couple two or more containers without significant physical effort, and without the significant understanding of the mechanics of the present invention.

[0061] Although the description above contains many specifics, these should not be construed as limiting the scope of the invention, but as merely providing illustrations of some of the presently preferred embodiments of this invention. For example, TIA **12** and BIA **30** end closures can be used on a variety of container sizes, including varying diameters of end closures, as well varying heights and volumes of the associated containers. Thus, the scope of the present invention should not be limited to the examples provided.

[0062] The preceding examples can be repeated with similar success by substituting the generically or specifically described reactants and/or operating conditions of this invention for those used in the preceding examples.

[0063] Although the invention has been described in detail with particular reference to these preferred embodiments, other embodiments can achieve the same results. Variations and modifications of the present invention will be obvious to those skilled in the art and it is intended to cover in the appended claims all such modifications and equivalents. The entire disclosures of all references, applications, patents, and publications cited above and/or in the attachments, and of the corresponding application(s), are hereby incorporated by reference.

1. A mixing apparatus comprising:
 - first and second containers comprising first and second ends;
 - an engagement interface formable between a first and second end of said containers; and
 - wherein said first and second containers are openable by a rotational force at said engagement interface.
2. The apparatus of claim 1 wherein said engagement interface comprises a seal.
3. The apparatus of claim 1 further comprising a locking mechanism.
4. The apparatus of claim 1 further comprising an alignment mechanism.
5. The apparatus of claim 1 wherein said first and second containers are locked together with the locking mechanism by counter-rotation of said first and said second containers.
6. The apparatus of claim 1 wherein said engagement interface comprises at least one tab, at least one hook, at least one catch, at least one scored panel, and at least one fastener.
7. An openable container apparatus comprising:
 - an opening mechanism, said container openable from a rotational force applied to said mechanism and said container openable from a cantilever force.
8. The apparatus of claim 7 wherein said opening mechanism comprises a tab.
9. The apparatus of claim 7 wherein said opening mechanism comprises an at least partially movable opening cover.
10. The apparatus of claim 7 wherein said opening mechanism comprises a hinge.
11. The apparatus of claim 7 wherein said opening mechanism comprises a stop.
12. The apparatus of claim 9 further comprising a recess disposed in said cover.
13. The apparatus of claim 7 wherein said opening mechanism comprises a first tab comprising a first hook that is engagable with a first scored panel, said tab attached to said opening mechanism with a fastener.

14. The apparatus of claim 7 wherein said opening mechanism comprises a locking mechanism.

15. The apparatus of claim 7 wherein said opening mechanism comprises a seal.

16. The apparatus of claim 7 wherein said opening mechanism comprises an aligning mechanism.

17. The apparatus of claim 16 wherein said aligning mechanism comprises an alignment key, at least one slot and at least one band that aligns with said slot.

18. The apparatus of claim 7 wherein said opening mechanism comprises a second tab.

19. The apparatus of claim 7 further comprising a ridge disposed at least partially around the perimeter of said first scored panel and second scored panel.

20. A method for mixing two or more substances comprising:

providing two or more containers, the containers comprising first and second ends;

engaging at least two of the containers at an interface, the interface comprised of at least a first end of one of the containers and a second end of another of the containers; opening the engaged containers at or near the interface by the application of a counter-rotational force between the containers; and

mixing at least a portion of the contents of the engaged containers.

21. The method of claim 20 further comprising forming an at least substantially water-tight seal between the engaged containers.

22. The method of claim 20 further comprising locking the engaged containers together with a locking mechanism.

23. The method of claim 20 further comprising an aligning mechanism for engaging the at least two containers.

* * * * *