

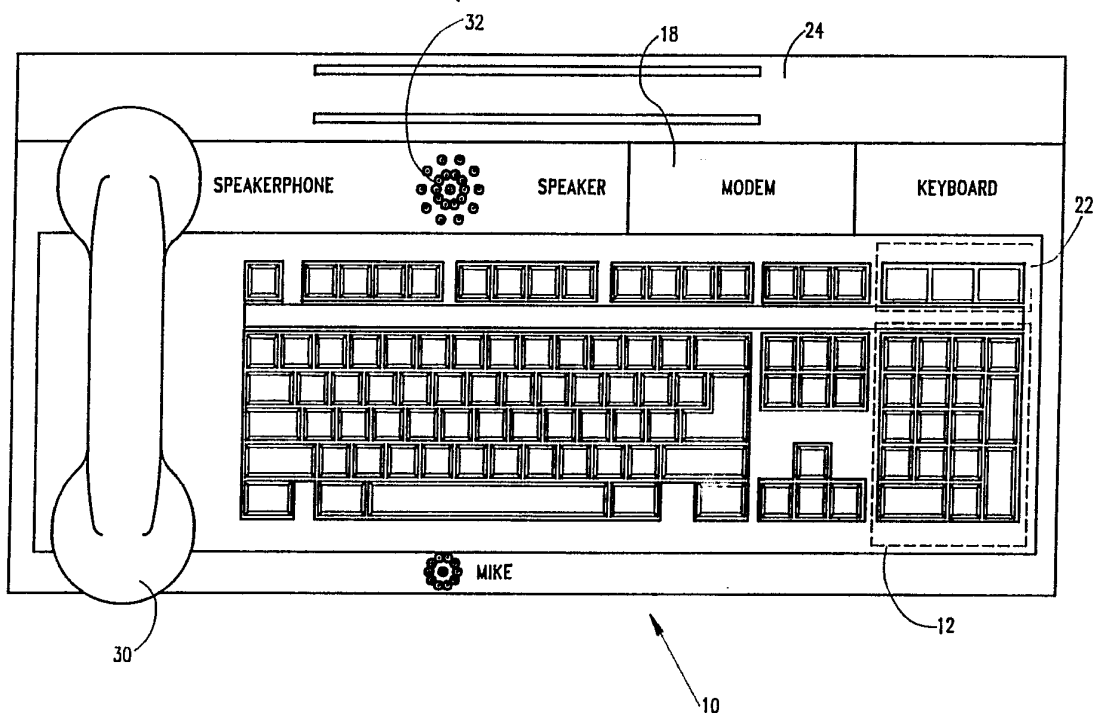

INTERNATIONAL APPLICATION PUBLISHED UNDER THE PATENT COOPERATION TREATY (PCT)

<p>(51) International Patent Classification ⁵ : H04M 11/00</p>	<p>A1</p>	<p>(11) International Publication Number: WO 92/03884 (43) International Publication Date: 5 March 1992 (05.03.92)</p>
<p>(21) International Application Number: PCT/US91/05710 (22) International Filing Date: 12 August 1991 (12.08.91) (30) Priority data: 567,403 14 August 1990 (14.08.90) US (71)(72) Applicants and Inventors: HABER, Alan, P. [US/IL]; Mishol Uzrad 11/1, Ramot 02, 91 999 Jerusalem (IL). SASLOW, Roy, J. [US/IL]; 2 David Bazov Street, Ramot 03, 91 999 Jerusalem (IL). (74) Agents: LERCH, Joseph, B. et al.; Darby & Darby, 805 Third Avenue, New York, NY 10022 (US).</p>		<p>(81) Designated States: AT (European patent), BE (European patent), CA, CH (European patent), DE (European patent), DK (European patent), ES (European patent), FR (European patent), GB (European patent), GR (European patent), IT (European patent), JP, LU (European patent), NL (European patent), SE (European patent). Published <i>With international search report.</i> <i>With amended claims.</i></p>

(54) Title: A COMPUTER KEYBOARD



(57) Abstract

A computer keyboard is disclosed which includes an alphanumeric keypad (10), a numeric keypad (12) and at least one of the following: a document scanner (24), a speakerphone (32), and a modem (18). The numeric keypad (12) is operative for the speakerphone (32) and the keyboard.

FOR THE PURPOSES OF INFORMATION ONLY

Codes used to identify States party to the PCT on the front pages of pamphlets publishing international applications under the PCT.

AT	Austria	ES	Spain	MG	Madagascar
AU	Australia	FI	Finland	ML	Mali
BB	Barbados	FR	France	MN	Mongolia
BE	Belgium	GA	Gabon	MR	Mauritania
BF	Burkina Faso	GB	United Kingdom	MW	Malawi
BG	Bulgaria	GN	Guinea	NL	Netherlands
BJ	Benin	GR	Greece	NO	Norway
BR	Brazil	HU	Hungary	PL	Poland
CA	Canada	IT	Italy	RO	Romania
CF	Central African Republic	JP	Japan	SD	Sudan
CG	Congo	KP	Democratic People's Republic of Korea	SE	Sweden
CH	Switzerland	KR	Republic of Korea	SN	Senegal
CI	Côte d'Ivoire	LI	Liechtenstein	SU⁺	Soviet Union
CM	Cameroon	LK	Sri Lanka	TD	Chad
CS	Czechoslovakia	LU	Luxembourg	TG	Togo
DE*	Germany	MC	Monaco	US	United States of America
DK	Denmark				

+ Any designation of "SU" has effect in the Russian Federation. It is not yet known whether any such designation has effect in other States of the former Soviet Union.

5

10

A COMPUTER KEYBOARDField of the Invention

The present invention relates to computer key-
boards generally.

Background of the Invention

Various types of keyboards are known in the patent
literature. The following U.S. patents represent a sampling
of the art:

4,878,242; 4,918,723; 4,533,791; 4,759,053;
4,736,407; 4,839,919; 4,829,559; 4,860,342; 4,503,288;
4,873,715; 4,850,008; 4,827,085; 4,864,601.

Summary of the Invention

The present invention seeks to provide a general
purpose computer keyboard which is operative to provide, in
a single unit, multiple synergistic functions, which are not
presently provided in an integrated keyboard.

There is thus provided in accordance with a pre-
ferred embodiment of the invention a computer keyboard
including an alphanumeric keypad, a numeric keypad and at
least one of the following: a document scanner, a speaker-
phone and a modem.

In accordance with a preferred embodiment of the
invention there is provided a computer keyboard including an
alphanumeric keypad, a numeric keypad and a document scan-
ner.

In accordance with another preferred embodiment of the invention there is provided a computer keyboard including an alphanumeric keypad, a numeric keypad and a speakerphone.

5 In accordance with yet another preferred embodiment of the invention there is provided a computer keyboard including an alphanumeric keypad, a numeric keypad and a modem.

10 More preferably, the keyboard includes at least two of the following: document scanner, speakerphone and modem.

Most preferably, the keyboard includes a document scanner, speakerphone and modem.

15 Finally, preferably, the numeric keypad is operative for the speakerphone and the keyboard together.

Brief Description of the Drawings

The present invention will be understood and appreciated more fully from the following detailed description, taken in conjunction with the drawings in which:

Figure 1 is a generalized pictorial illustration of a keyboard constructed and operative in accordance with a preferred embodiment of the present invention;

25 Figure 2 is a generalized block diagram illustration of the keyboard of Fig. 1;

Figure 3 is an electronic block diagram illustration of a keyboard;

30 Figures 4A and 4B are electronic block diagrams of portions of a speakerphone circuit useful in the keyboard of Fig. 1;

Figure 5 is an electronic block diagram illustration of a modem circuit useful in the keyboard of Fig. 1;

35 Figure 6 is an electronic block diagram illustration of a scanner circuit useful in the keyboard of Fig. 1; and

Figures 7A and 7B are generalized block diagrams of the keyboard of Fig. 1 with two alternate numeric keypad control circuits.

Detailed Description of a Preferred Embodiment

Reference is now made to Figs. 1 and 2, which illustrate a keyboard constructed and operative in accordance with a preferred embodiment of the present invention.

5 The keyboard comprises an alphanumeric keypad 10, which may be identical to that used in conventional personal computers manufactured by IBM and others.

The keyboard of the present invention also preferably comprises a numeric keypad 12, typically arranged in
10 the form of a computer numeric keyboard rather than in the form of a DTMF telephone keypad.

The alphanumeric keypad 10 is associated with a keyboard circuit 14, which may be a conventional keyboard circuit employed in commercially available IBM PC keyboards.
15 The keyboard circuit 14 may be coupled via a connector cable to the keyboard plug socket of a computer, such as a personal computer.

The numeric keypad is coupled via a control circuit 16 to keyboard circuit 14, modem 18 and speakerphone
20 20. Control circuit 16 is operated by means of a control keypad 22. Control keypad 22 typically comprises three keys on the keyboard. For example, they may be a keyboard/dialpad mode switch 42, a scanner on/off switch 41 and a speakerphone on/off switch 43.

25 The modem 18 is coupled via serial line, such as an RS 232 line, to a computer. A document scanner 24, such as a CD122 or a CCD 142DB of Fairchild Semiconductor of West Germany, may also be coupled via a serial line to the computer. Scanner 24 is also typically connected to control
30 circuit 16 and is operable as an input device for the computer. The speakerphone 20 typically comprises a handset 30 and a loudspeaker 32 and is coupled to a telephone line, as is modem 18.

Reference is now made to Fig. 3 which illustrates
35 the keyboard circuit 14 which is the circuitry of the TH-5539AT, RT.XT keyboard manufactured by Chickory of Taiwan utilizing the 8748 keyboard CPU manufactured by Intel of the USA. The full specification of all of the circuit compo-

SUBSTITUTE SHEET

nents appears in the drawing and therefore, for reasons of conciseness, a verbatim description thereof is not provided here. However, it will be noted that switches 36 of a numeric keypad 98 have been marked, as has a keyboard CPU
5 38.

Reference is now made to figs. 4A and 4B which illustrate circuitry of speakerphone 20. Figure 4A is the speakerphone specification published by Motorola Semiconductors of the USA as Data Spec Sheets MC34014 and MC34018.
10 Figure 4B is the speakerphone specification published by Motorola Semiconductors of the USA as Data Spec Sheet MC34118. The full specification of all of the circuit components appears in the drawings and therefore, for reasons of conciseness, a verbatim description thereof is not
15 provided here. However, it will be noted that a second numeric keypad 100 is marked.

Reference is now made to Fig. 5 which illustrates the circuitry for modem 18. Figure 5 is taken from the Motorola Semiconductors Data Spec Sheet MC6860. The full
20 specification of all of the circuit components appears in the drawing and therefore, for reasons of conciseness, a verbatim description thereof is not provided here. Reference is now made to Fig. 6 which is an illustration of circuitry for scanner 24. Figure 6 is taken from the Fair-
25 child Charge Coupled Device Catalogue, 1984, Page 80. The full specification of all of the circuit components appears in the drawing and therefore, for reasons of conciseness, a verbatim description thereof is not provided here.

Reference is now made to Figs. 7A and 7B which
30 illustrate two embodiments of control circuit 16 in conjunction with keyboard circuit 14 and speakerphone 20. As shown in Fig. 1, in accordance with the present invention, there is only one numeric keypad 12. The first and second numeric keypads 98 and 100 of Figs. 3 and 4B, respectively, are
35 typically embodied in a single numeric keypad 12 comprising switches 36 (Figs. 3). For the embodiment of Fig. 7A, the switches 36 are double pole switches directly connected to both keyboard CPU 38 (shown also in Fig. 3) and a telephone

dialer 40 (shown also in Fig. 4B). Keyboard CPU 38 and telephone dialer 40 are also connected to keyboard/dialpad mode switch 42 forming part of control keypad 22.

When switch 42 is in a first keyboard mode, it
5 enables keyboard CPU 38 and disables telephone dialer 40, thereby enabling numeric and alphabetic input to the computer. When switch 42 is in a second dialpad mode, it disables the keyboard CPU 38 and enables telephone dialer 40, thereby enabling the numeric keypad 12 of the present invention to
10 be utilized as a telephone keypad.

In accordance with an alternate embodiment of the present invention and as shown in Fig. 7B, switch 42 is connected to keypad CPU 38 and to telephone dialer 40. As in the previous embodiment, when switch 42 is in the first
15 mode, the keyboard is enabled and the telephone dialer 40 is disabled. The keyboard data is sent, via a serial data line, to a computer (not shown). However, in this embodiment, when the telephone dialer 40 is enabled, the keyboard CPU 38 remains enabled and receives the data from numeric
20 keypad 12. The serial data line is switched, via switch 47 which is operated by switch 42, to send data to the now enabled telephone dialer 40. In this embodiment, telephone dialer 40 is modified, in a manner known to one skilled in the art, to receive keyboard signals and to encode them to
25 DTMF signals for the speakerphone 20.

In accordance with the present invention, as shown in both Figs. 7A and 7B, when the numeric keypad 12 is utilized as a telephone keypad, the keys +, -, Enter and *, are redefined to perform the redial, auto, memory and flash
30 features of a speakerphone 20, respectively.

It will be appreciated that the entirety of keys of both the alphanumeric and numeric keypads 10 and 12, respectively, can be utilized for advanced telephone features, as required. For the embodiment of Fig. 7A, the
35 entirety of keys of keypads 10 and 12 can be implemented as double pole switches. For the embodiment of Fig. 7B, the entirety of keyboard data can be sent to the telephone dialer 40.

It will be appreciated by persons skilled in the art that the present invention is not limited to what has been particularly shown and described hereinabove. Rather the scope of the present invention is defined only by the 5 claims which follow:

SUBSTITUTE SHEET

What Is Claimed Is:

1 1. A computer keyboard comprising an alphanumer-
2 ic keypad, a numeric keypad and at least one of the follow-
3 ing: a document scanner, a speakerphone, and a modem.

1 2. A computer keyboard comprising an alphanumer-
2 ic keypad, a numeric keypad and a document scanner.

1 3. A computer keyboard comprising an alphanumer-
2 ic keypad, a numeric keypad and a speakerphone.

1 4. A computer keyboard comprising an alphanumer-
2 ic keypad, a numeric keypad and a modem.

1 5. A computer keyboard comprising at least two
2 of the following: document scanner, speakerphone and modem.

1 6. A computer keyboard comprising a document
2 scanner, speakerphone and modem.

1 7. A computer keyboard according to Claim 1 and
2 wherein said numeric keypad is operative for said speaker-
3 phone.

AMENDED CLAIMS

[received by the International Bureau on 7 December 1991 (07.12.91);
original claims 1-7 replaced by amended claims 1-20 (4 pages)]

1. A computer keyboard for connection to a separate personal computer having a personal computer housing and comprising a keyboard housing separate from the personal computer housing and an alphanumeric keypad, a numeric keypad, connector cable means for connection only to the keyboard plug socket of the personal computer and at least one of the following: a document scanner, a speakerphone, and a modem disposed in the keyboard housing.

2. A computer keyboard for connection to a personal computer and comprising a keyboard housing separate from the personal computer and disposed therewithin an alphanumeric keypad, a numeric keypad and a document scanner and a connector cable arranged for connection to the keyboard plug socket of a personal computer.

3. A computer keyboard for connection to the keyboard plug socket of a personal computer and comprising an alphanumeric keypad, a numeric keypad, a speakerphone and a connector cable arranged for connection to the keyboard plug socket of a personal computer.

4. A computer keyboard for connection to the keyboard plug socket of a personal computer and comprising a keyboard housing separate from the personal computer, an alphanumeric keypad, a numeric keypad, and a modem and a connector cable arranged for connection to the keyboard plug socket of a personal computer.

5. A computer keyboard for connection to the keyboard plug socket of a personal computer and comprising a keyboard

9.

housing separate from the computer and at least two of the following: document scanner, speakerphone and modem and a connector cable arranged for connection to the keyboard plug socket of a personal computer.

6. A computer keyboard for connection to the keyboard plug socket of a personal computer and comprising a keyboard housing separate from the computer, a document scanner, speakerphone and modem disposed within said keyboard housing.

8. A computer keyboard for connection to a separate personal computer having a personal computer housing and comprising a keyboard housing separate from the personal computer housing, an alphanumeric keypad and a numeric keypad arranged for connection to the keyboard plug socket of the personal computer and at least one of the following: a document scanner, a speakerphone, and a modem disposed in the keyboard housing.

9. A computer keyboard for connection to a personal computer and comprising an alphanumeric keypad and a numeric keypad arranged for connection to the keyboard plug socket of a personal computer and a document scanner, all being disposed in a keyboard housing separate from the personal computer.

10. A computer keyboard for connection to the keyboard plug socket of a personal computer and comprising alphanumeric and numeric keypad means for controlling the operation of the personal computer via said keyboard plug socket and a speakerphone disposed in a keyboard housing separate from the personal computer.

11. A computer keyboard for connection to a personal computer having a keyboard plug socket and comprising alphanumeric and numeric keypad means for controlling the operation of said personal computer via said keyboard plug socket and a modem, all disposed in a keyboard housing separate from the personal computer.

12. A computer keyboard for connection to the keyboard plug socket of a personal computer and comprising a keyboard housing separate from the computer, alphanumeric and numeric keypad means for controlling the operation of said personal computer via said keyboard plug socket and at least two of the following: document scanner, speakerphone and modem disposed in a keyboard housing separate from the personal computer.

13. A computer keyboard for connection to the keyboard plug socket of a personal computer and comprising a keyboard housing separate from the computer, alphanumeric and numeric keypad means for controlling the operation of said personal computer via said keyboard plug socket, a document scanner, speakerphone and modem disposed within said keyboard housing.

14. A computer keyboard according to claim 1 and wherein said numeric keyboard is arranged in the form of a computer numeric keyboard rather than in the form of a DTMF telephone keyboard.

15. A computer keyboard according to claim 2 and wherein said numeric keyboard is arranged in the form of a computer numeric keyboard rather than in the form of a DTMF telephone keyboard.

16. A computer keyboard according to claim 3 and wherein said numeric keyboard is arranged in the form of a computer numeric keyboard rather than in the form of a DTMF telephone keyboard.

17. A computer keyboard according to claim 4 and wherein said numeric keyboard is arranged in the form of a computer numeric keyboard rather than in the form of a DTMF telephone keyboard.

18. A computer keyboard according to claim 8 and wherein said numeric keyboard is arranged in the form of a computer numeric keyboard rather than in the form of a DTMF telephone keyboard.

19. A computer keyboard according to claim 9 and wherein said numeric keyboard is arranged in the form of a computer numeric keyboard rather than in the form of a DTMF telephone keyboard.

20. A computer keyboard according to claim 10 and wherein said numeric keyboard is arranged in the form of a computer numeric keyboard rather than in the form of a DTMF telephone keyboard.

STATEMENT UNDER ARTICLE 19

In view of the International Search Report of 29 October 1991 in the above-identified PCT application, please amend said application by substituting the attached pages 7 to 10 containing new claims 1 through 20 for original page 7 containing prior claims 1 through 7. The Examiner had cited a Holmes article, British Telecommunications, Vol. 5, January 1987, p. 273-275; a Cutler article from the Conference, Electrical Text Communication, Munich, Germany, 12-15 June 1978, pp. 323-329; a Durkin article from British Telecommunications Engineering, Vol. 5, January 1987, pp. 276-280; and Iggulden et al. U.S. patent 4,918,723 as of particular relevance to the priorily presented claims.

Also attached is a new page 11 containing a revised Abstract in view of the Invitation of 29 October 1991 to comment on the Abstract attached to that Invitation. As noted in this revised Abstract the reference number for the speakerphone has been changed to 32 to conform to page 30, lines 31-33 and to Fig. 2 of the application.

The claims have been rewritten more clearly to set forth the patentable distinctions of the invention over the prior art and specifically with reference to the art cited in the Search Report.

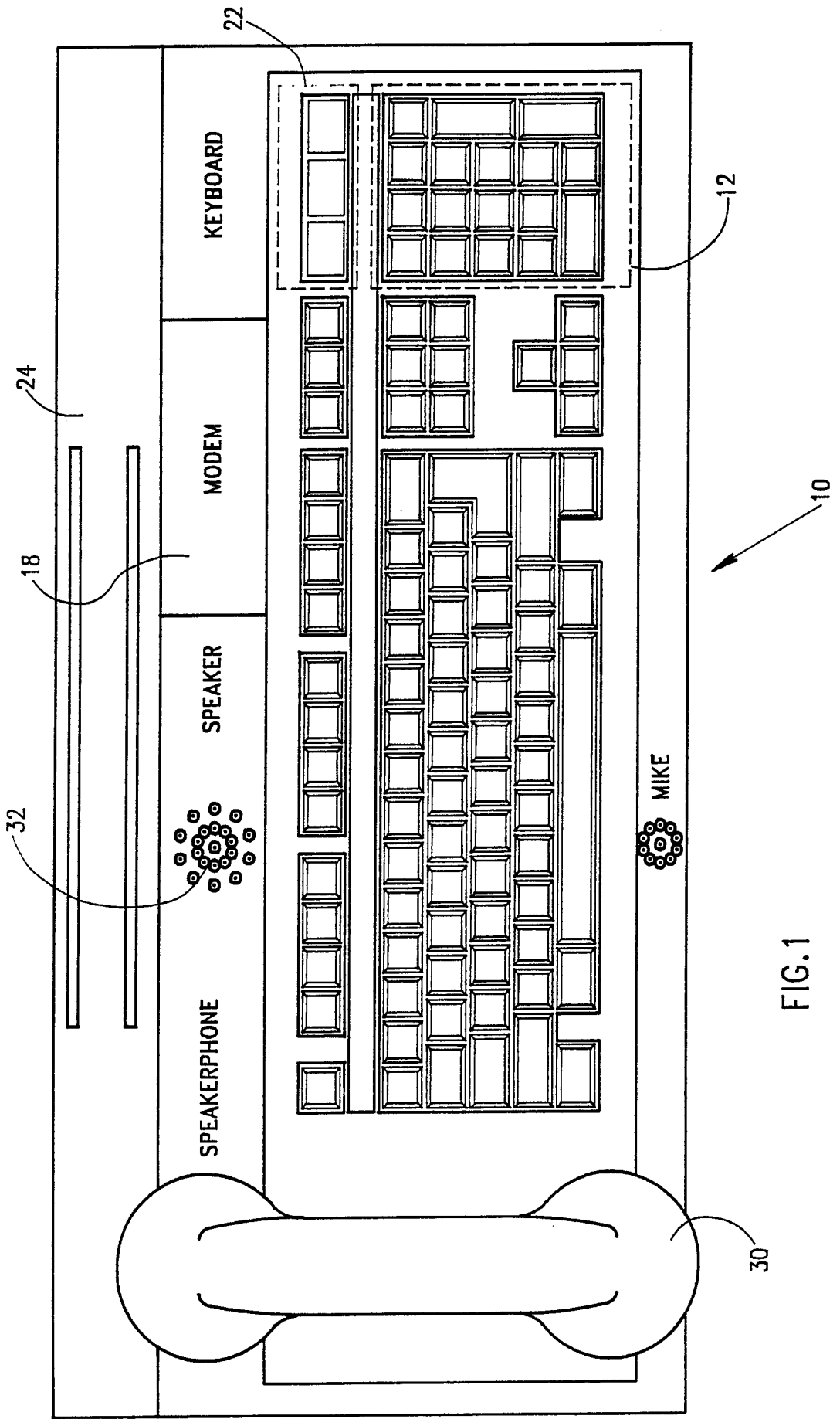

FIG. 1

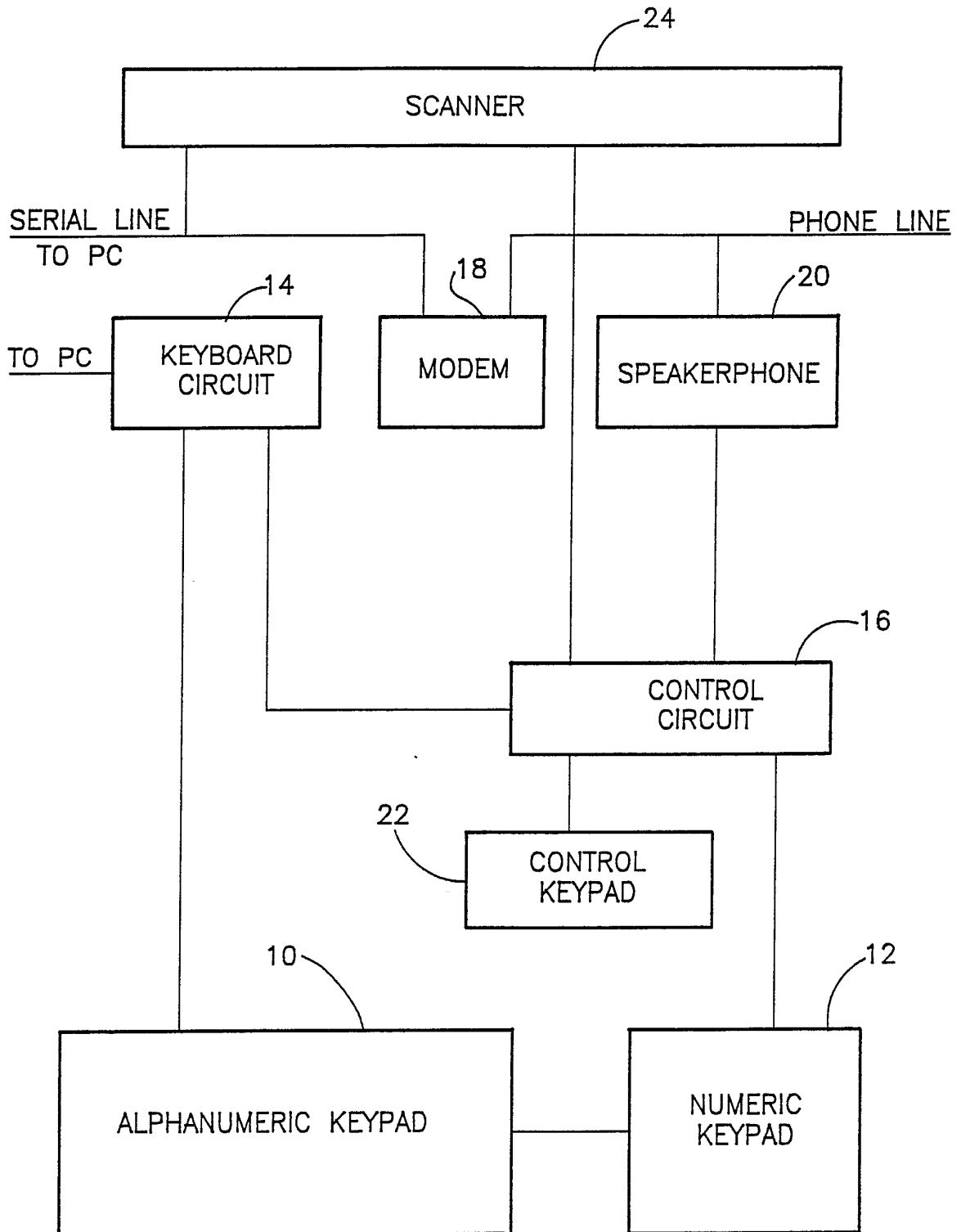

FIG. 2

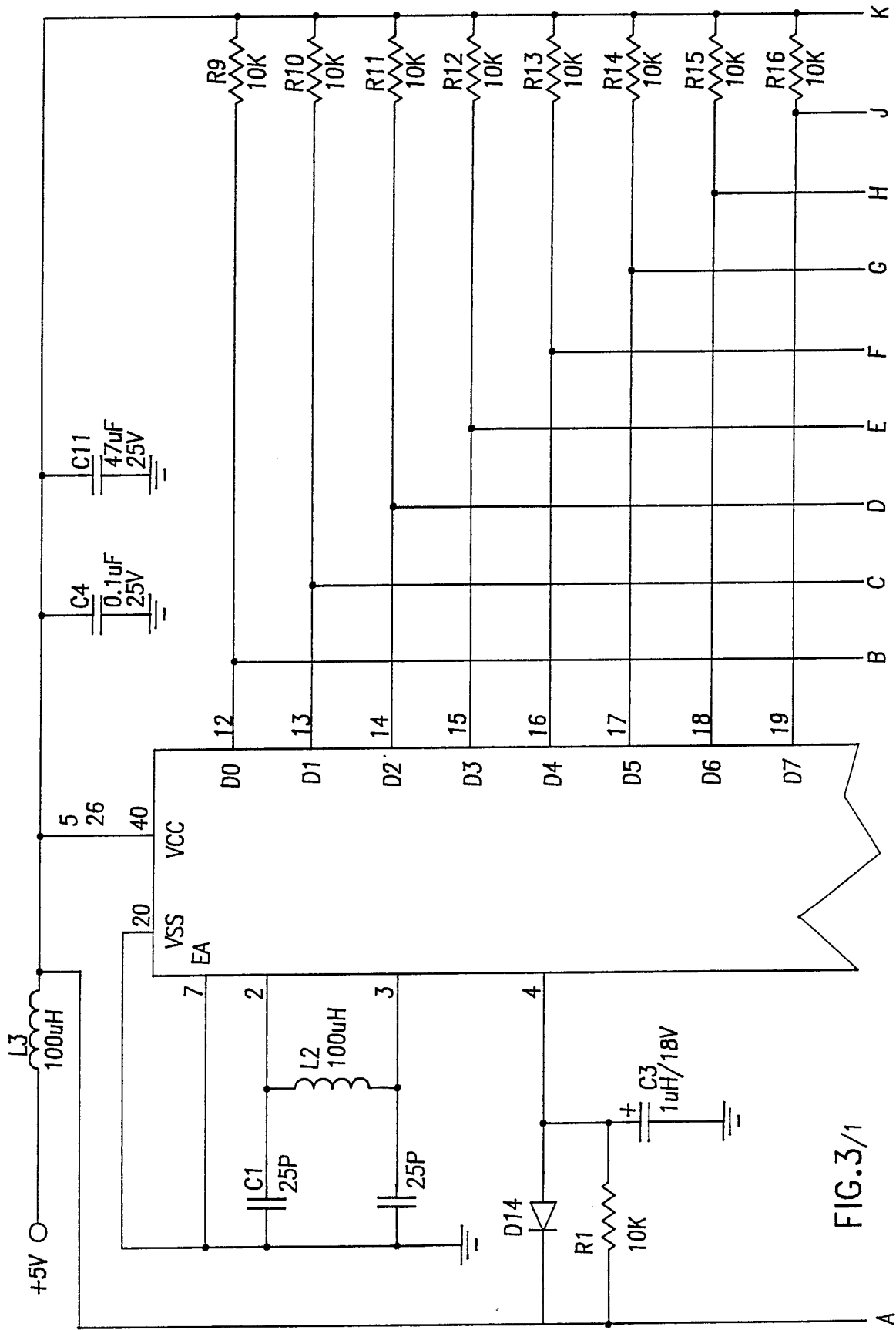

FIG.3/1

14 ↗

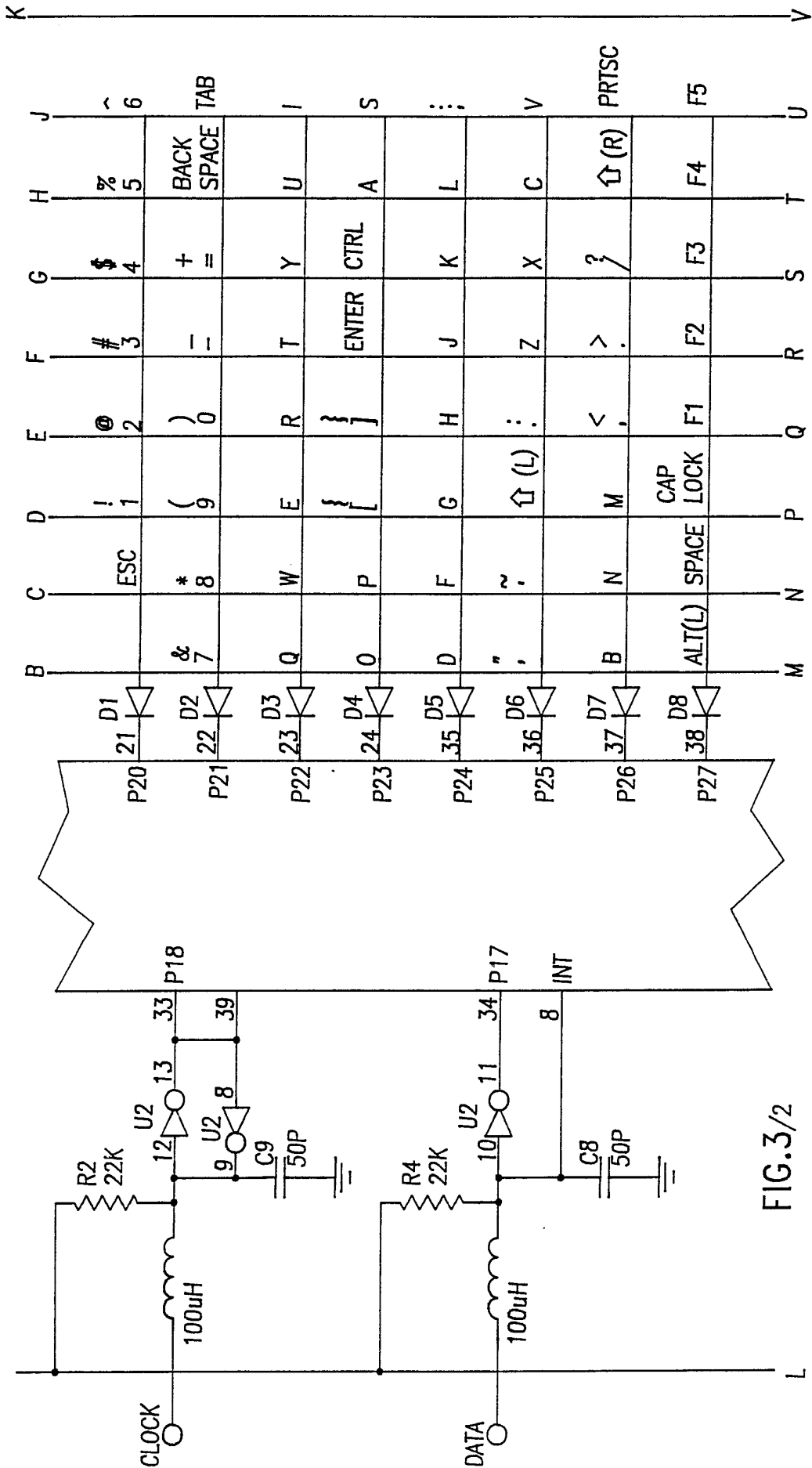

FIG.3/2

© 1992 International Business Machines Corporation

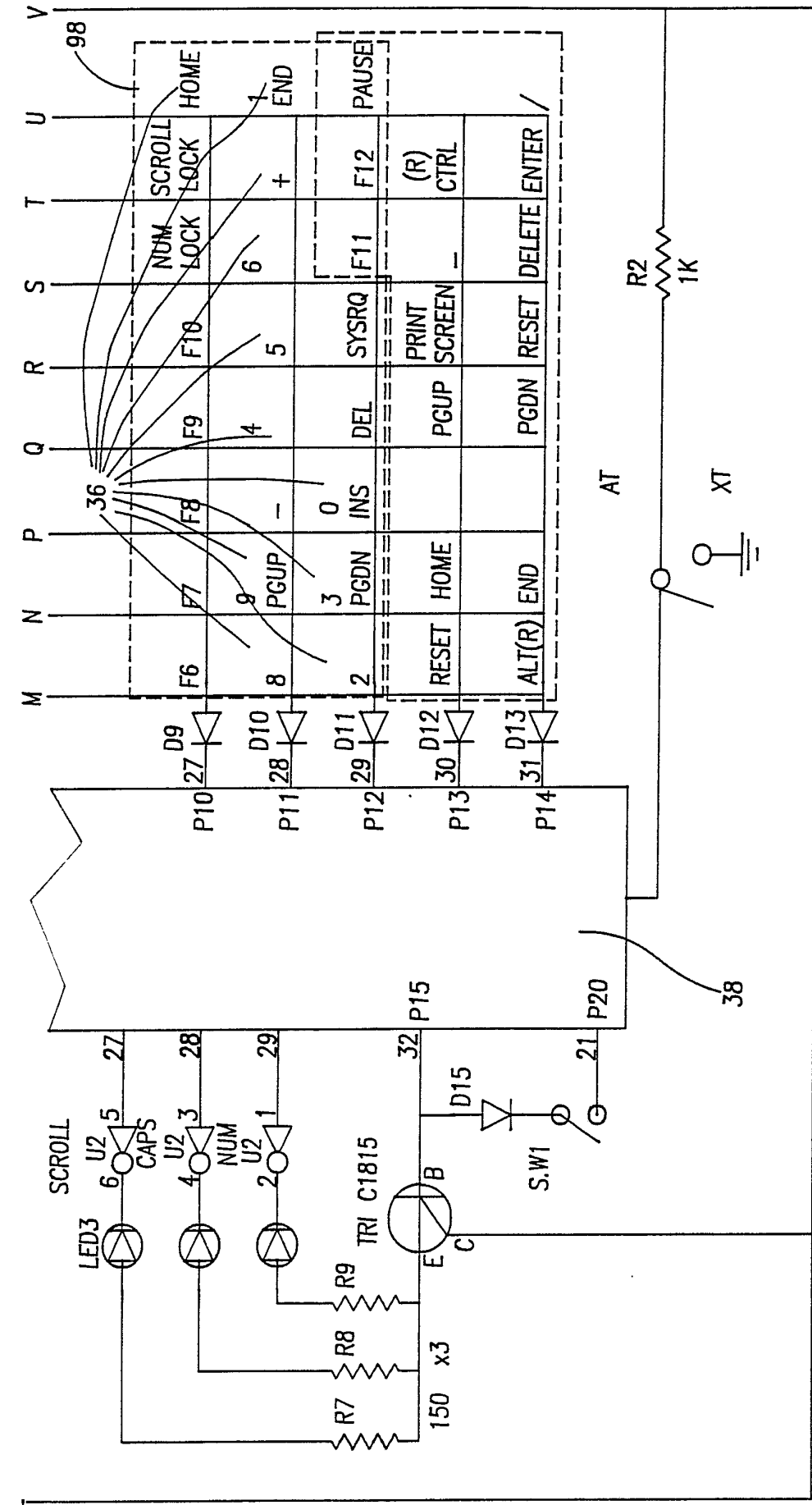

FIG.3/3

CONFIDENTIAL

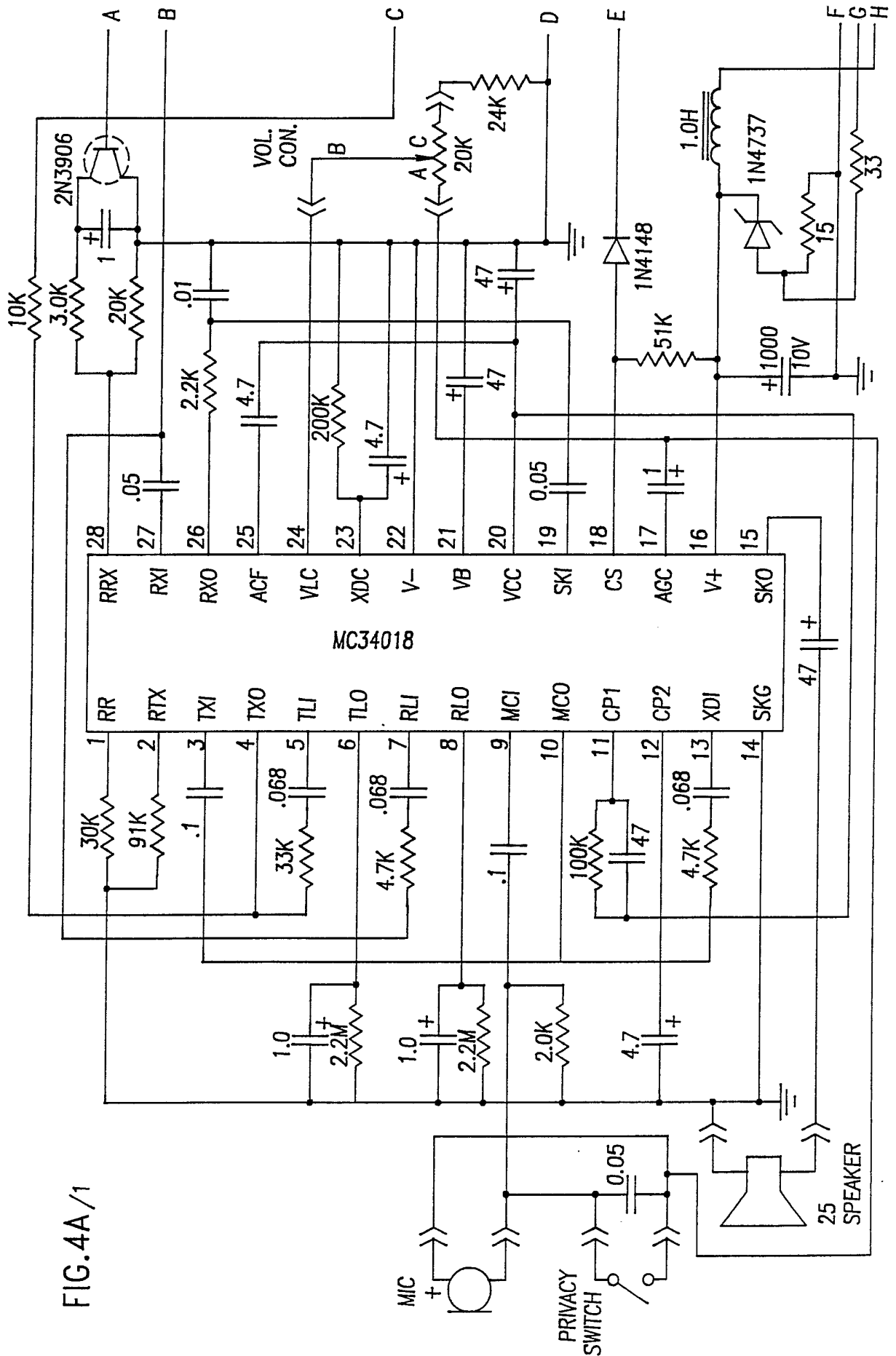

FIG. 4A/1

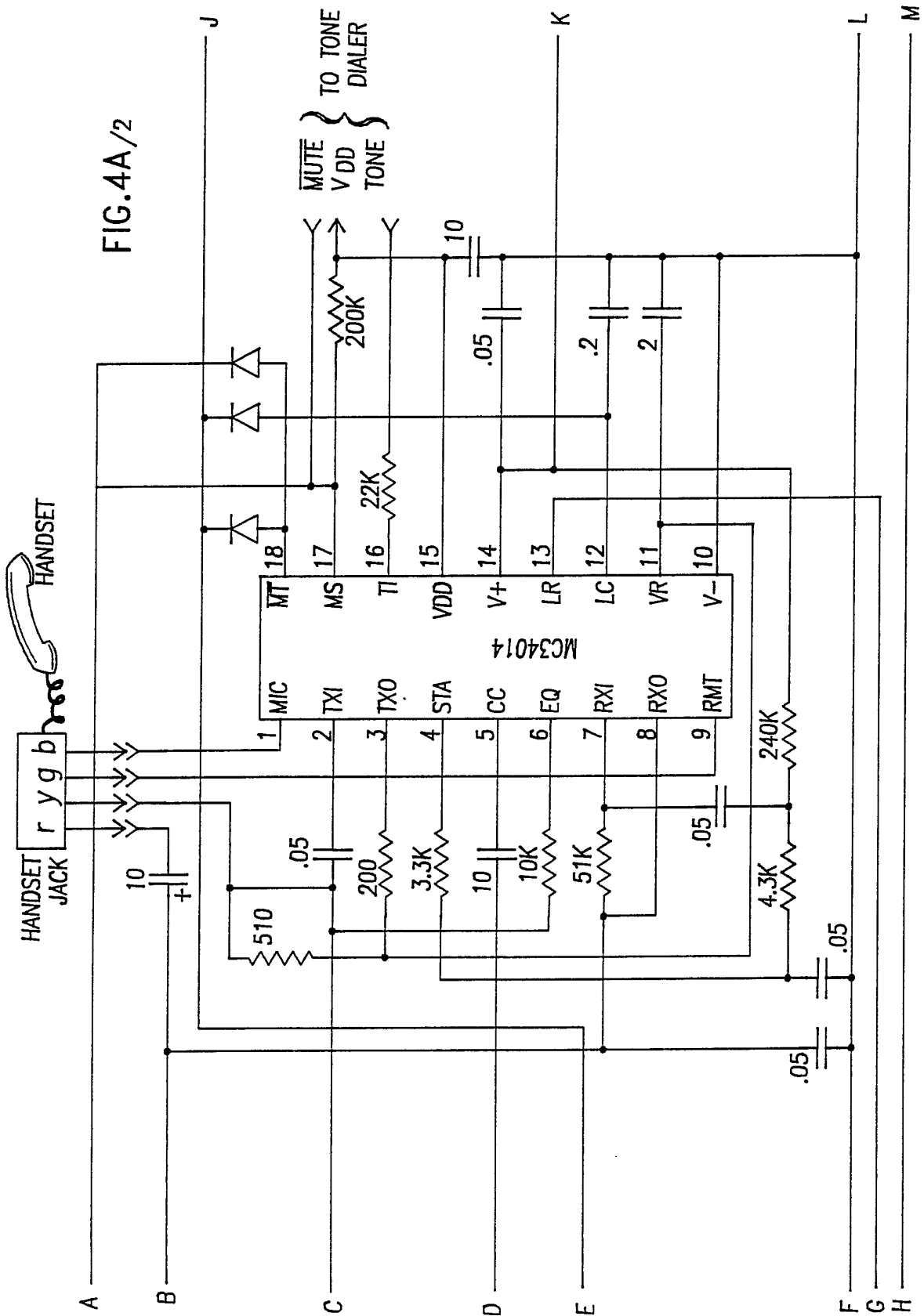
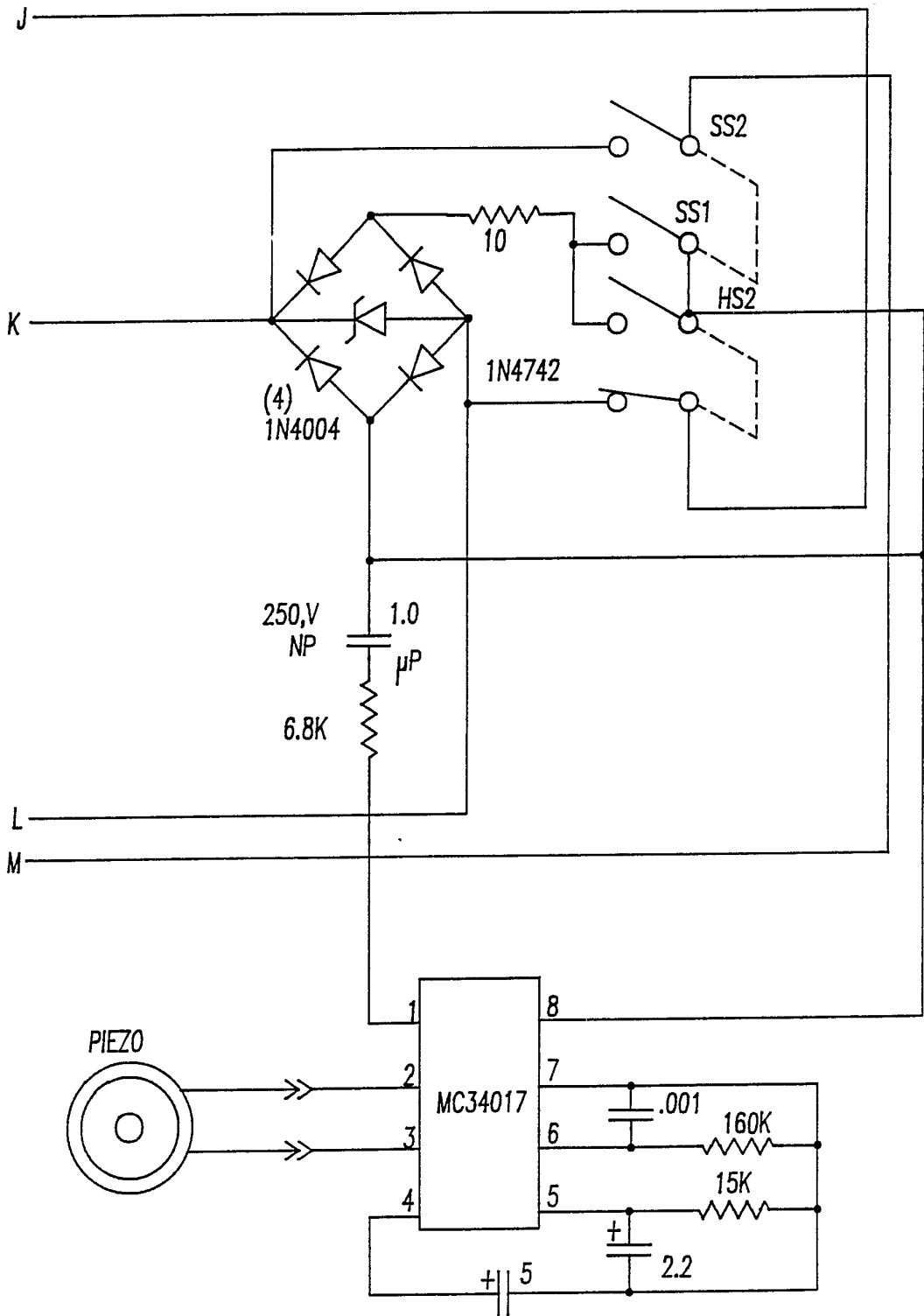

FIG. 4A/2



DIODES: 1N4148 EXCEPT WHERE NOTED

FIG.4A/3

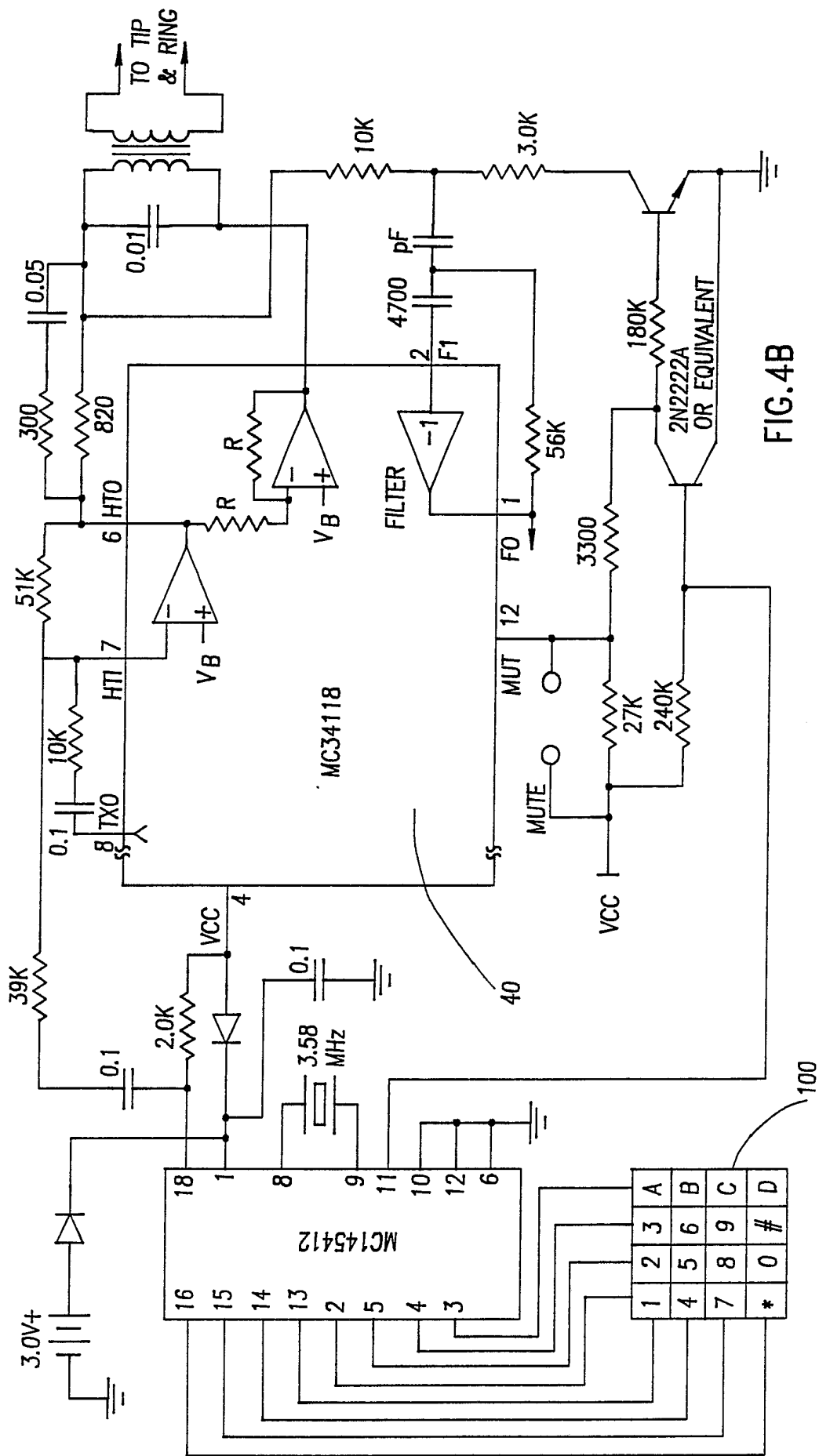

FIG. 4B

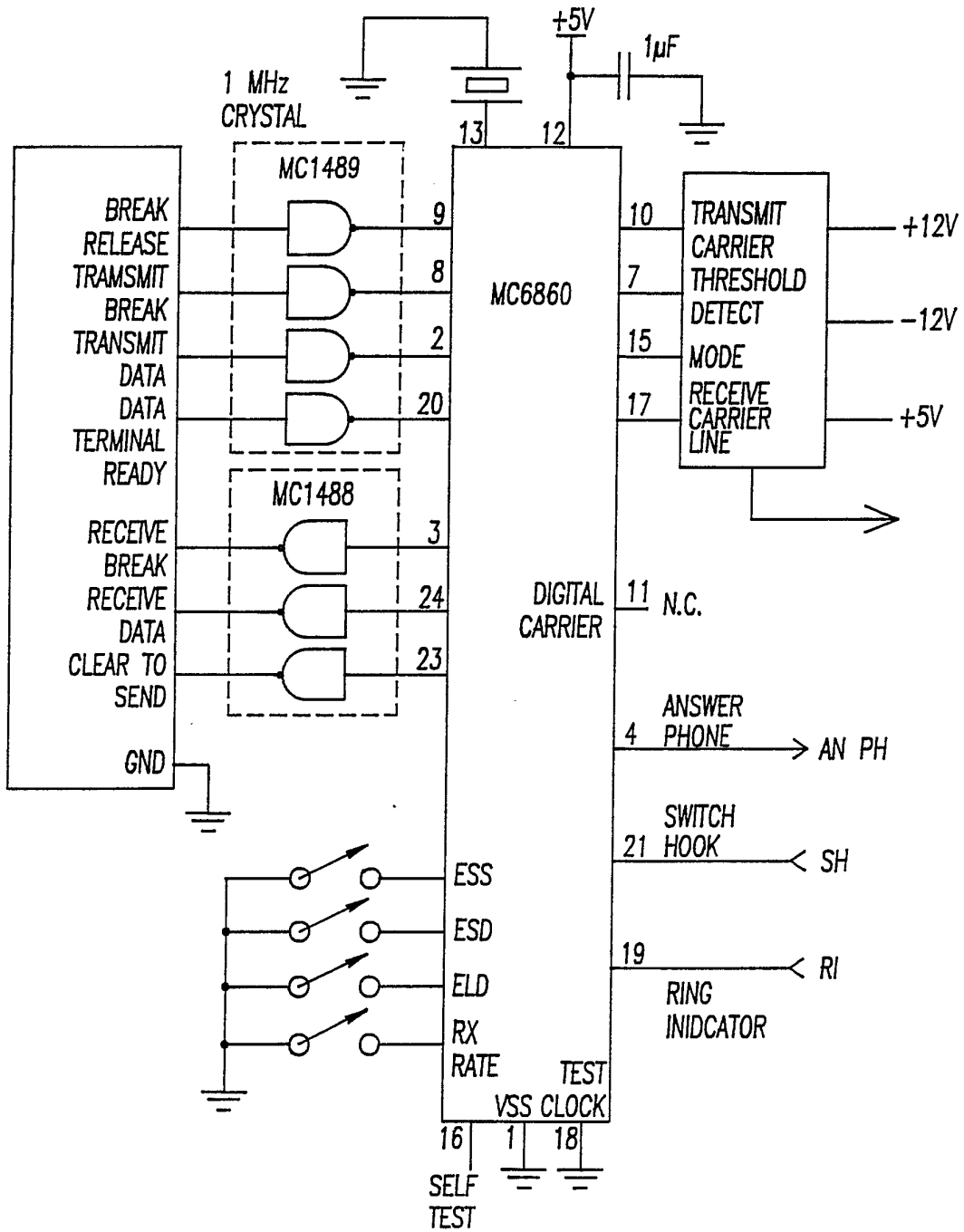

FIG.5/1

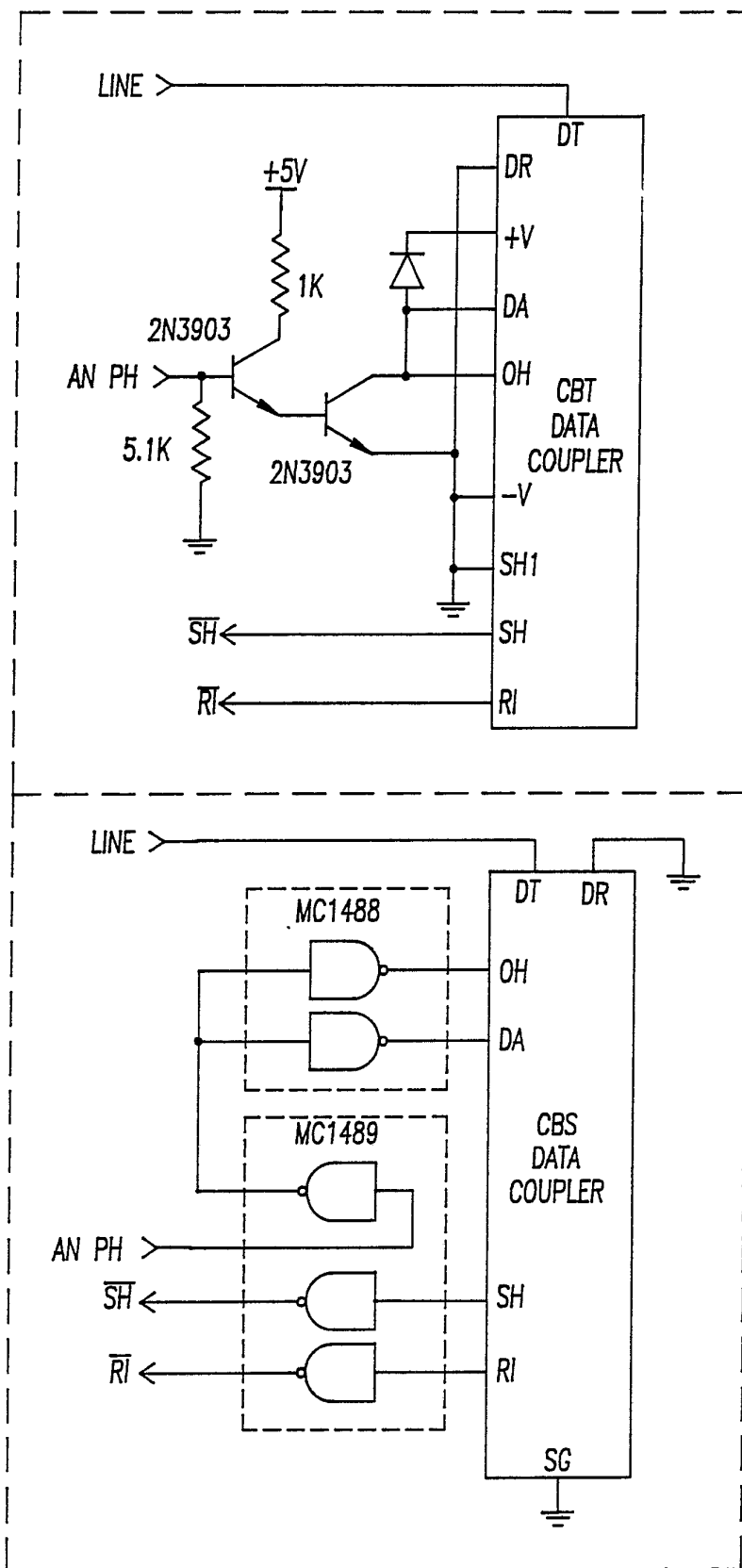

FIG.5/2

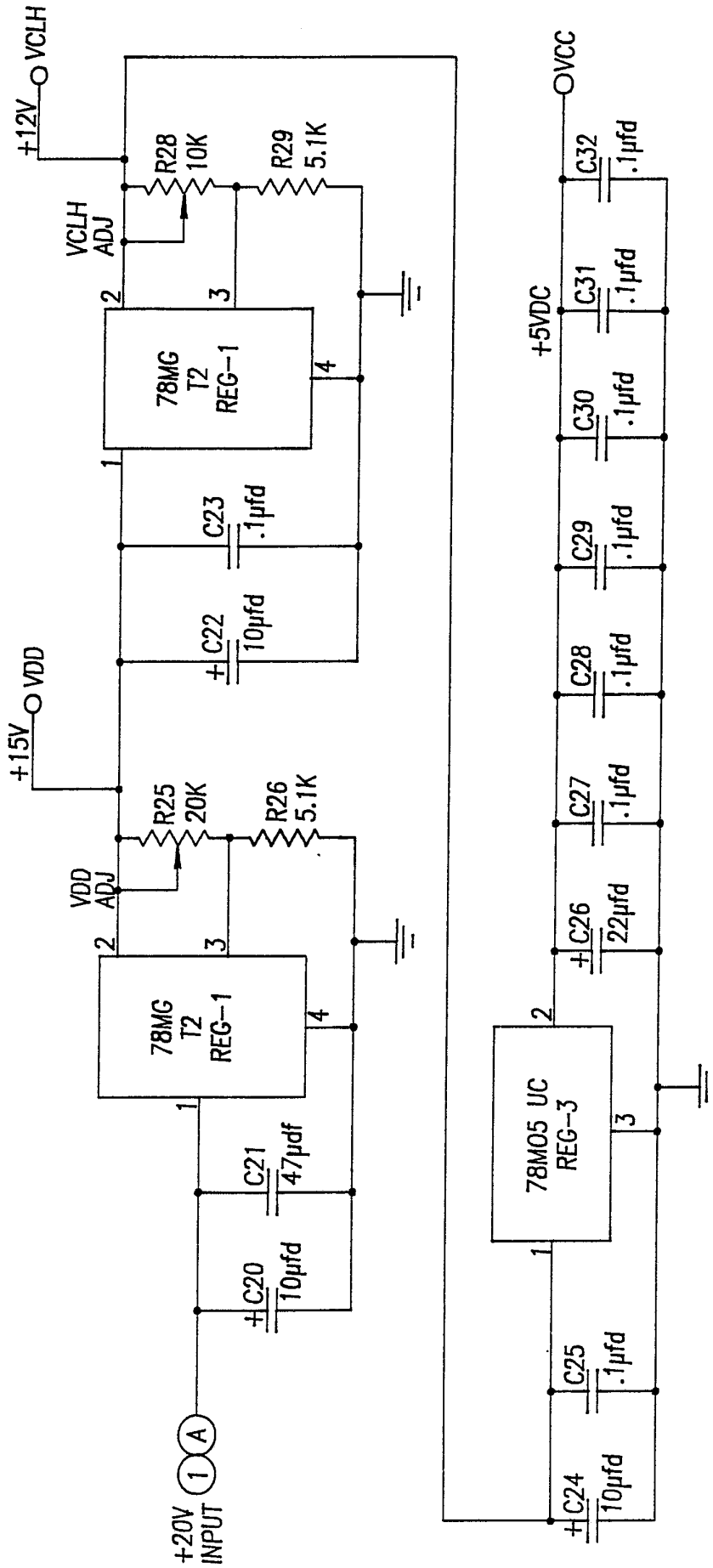

FIG.6 /1

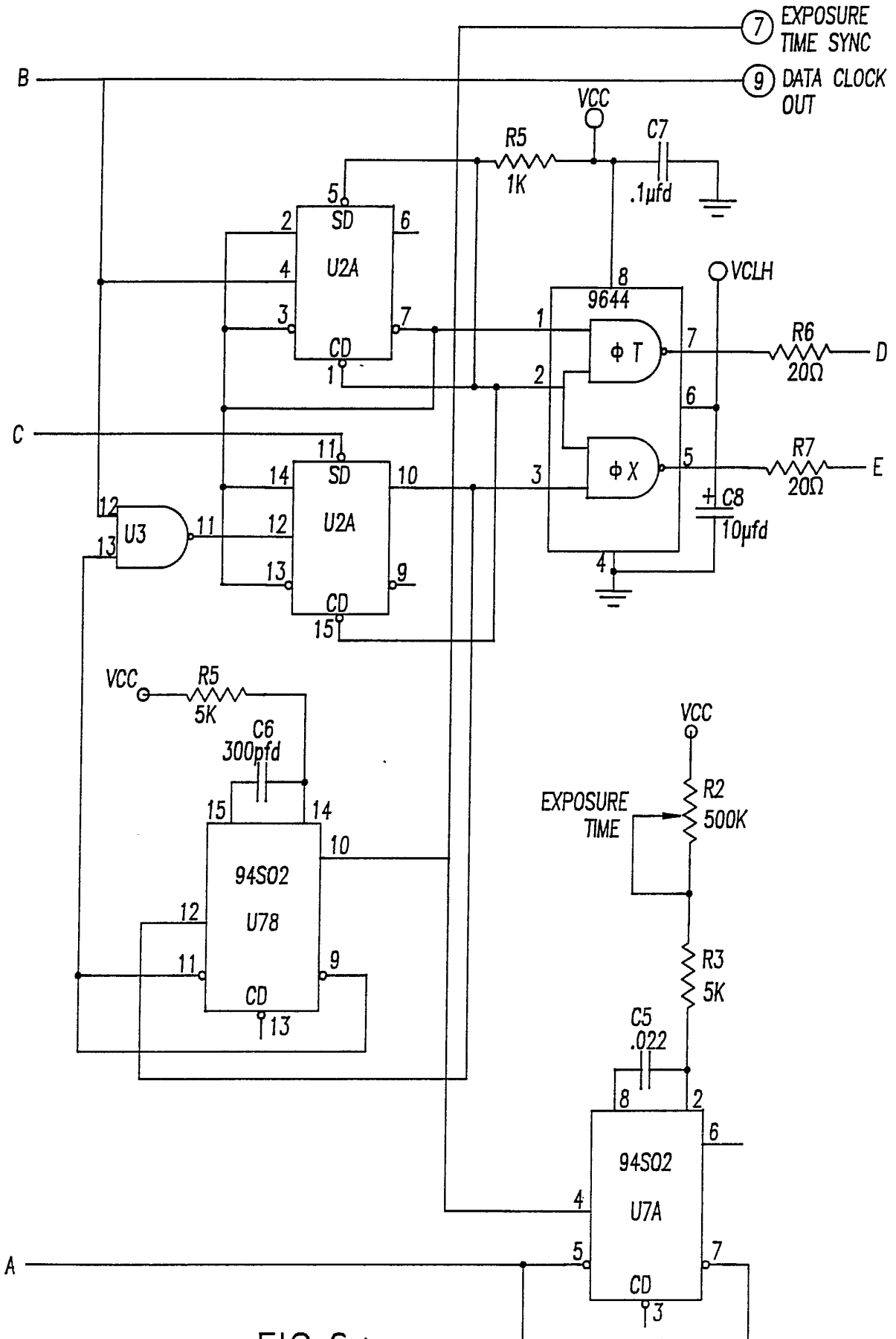

FIG. 6/3

SUBSTITUTE SHEET

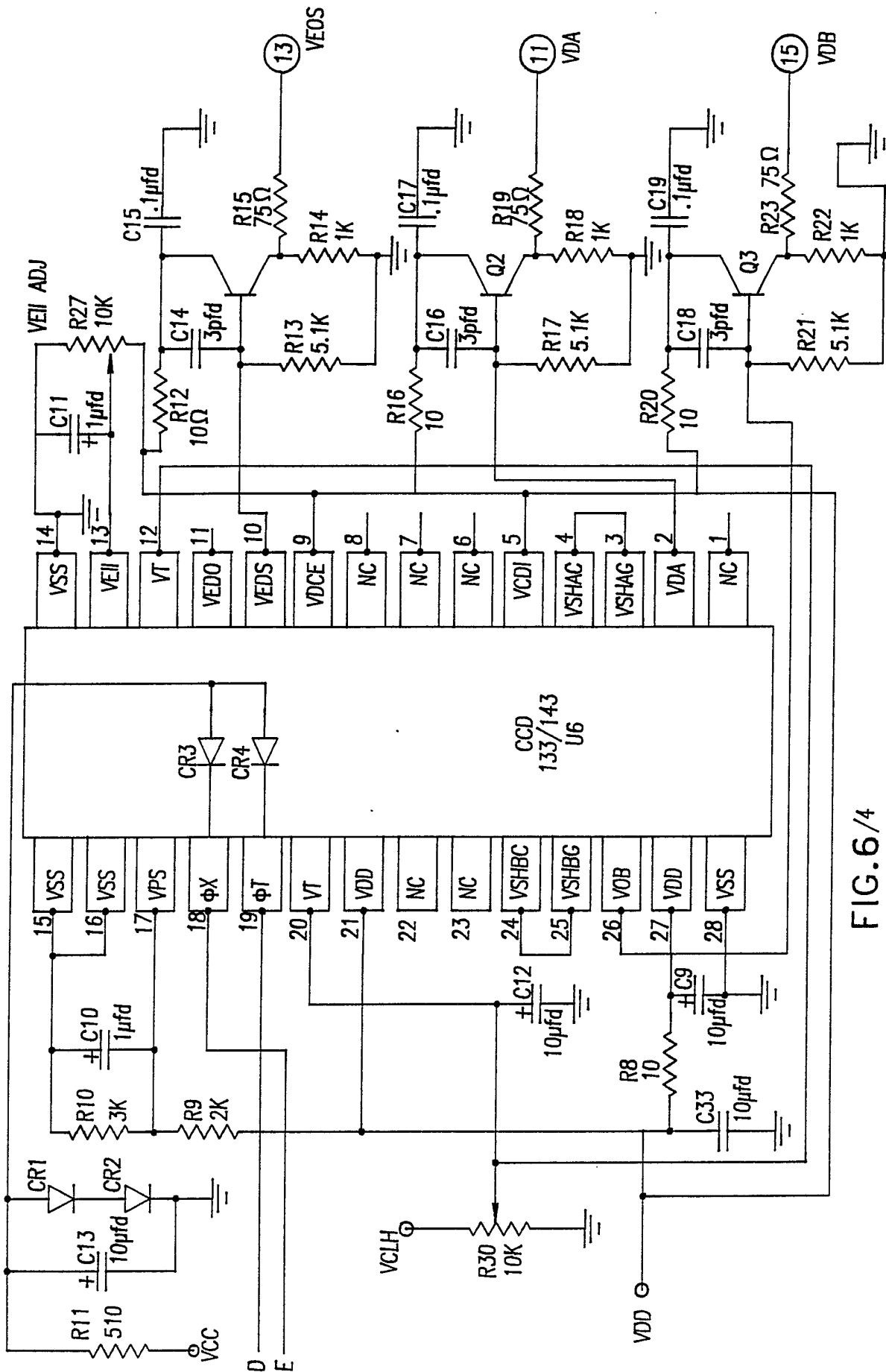
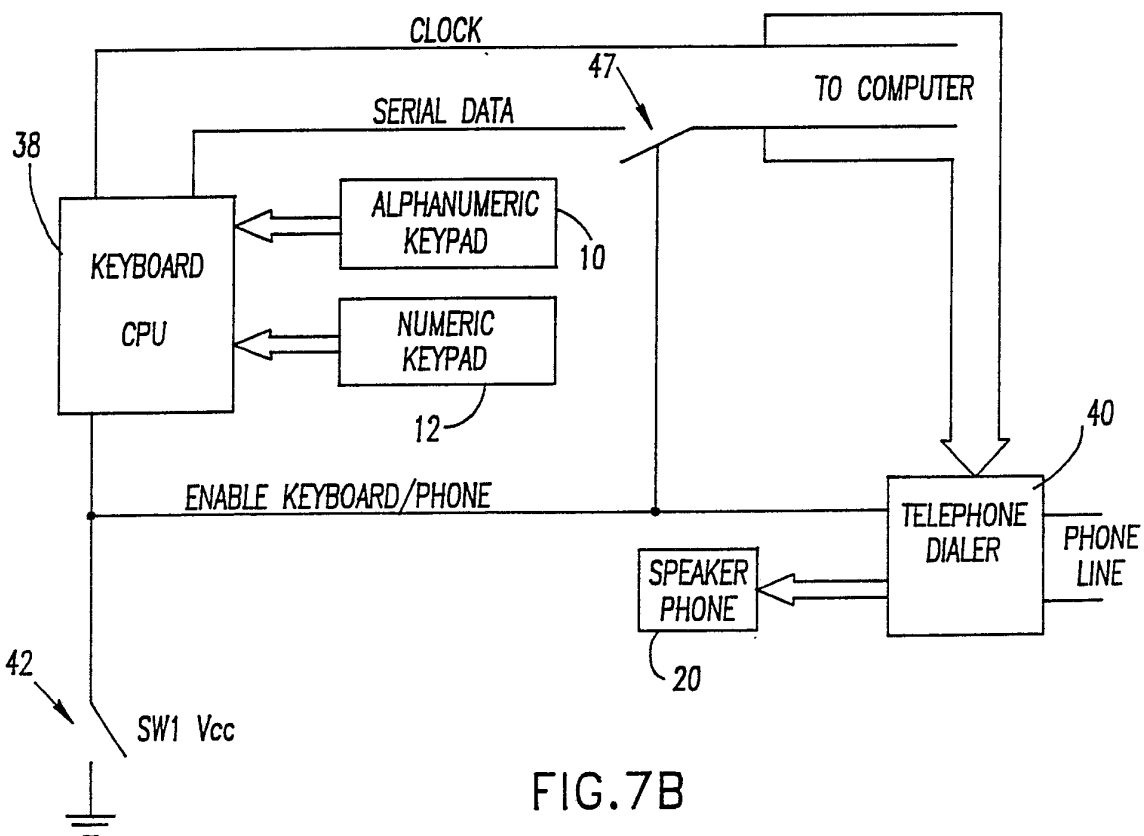
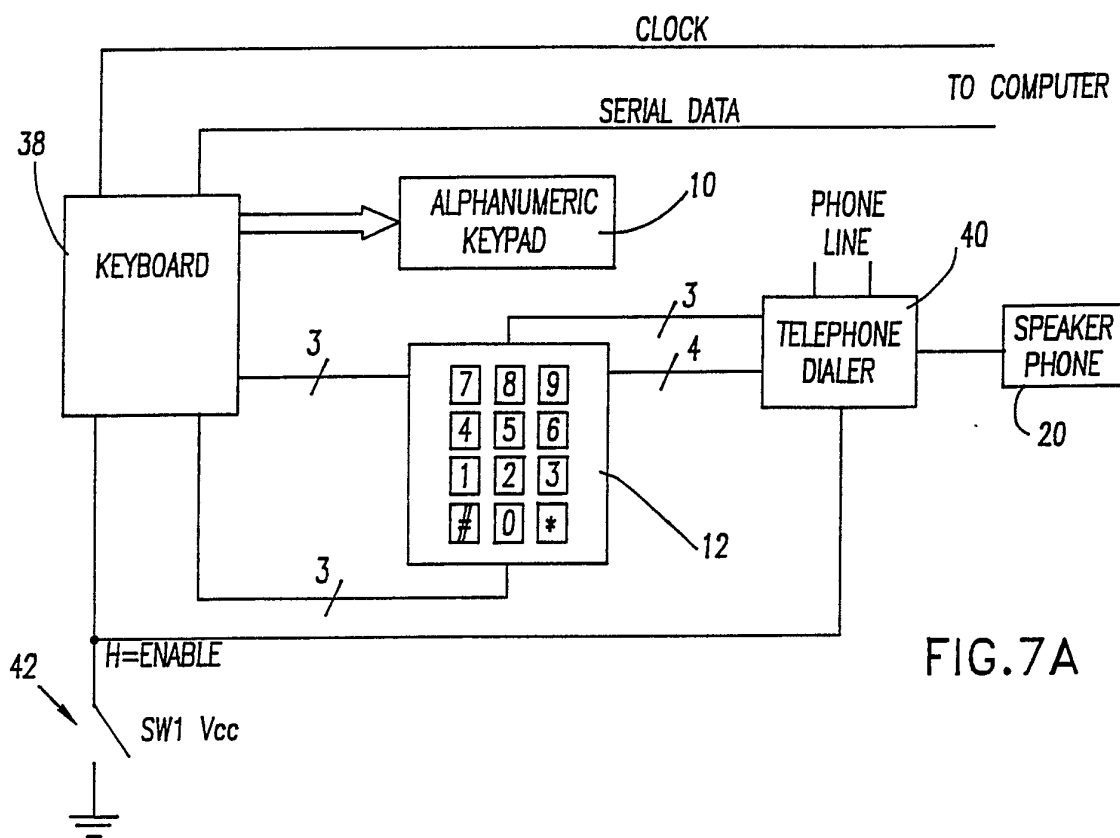

FIG.6/4



INTERNATIONAL SEARCH REPORT

International Application No.

PCT/US91/05710

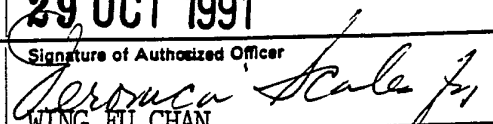
I. CLASSIFICATION OF SUBJECT MATTER (if several classification symbols apply, indicate all) ⁶		
According to International Patent Classification (IPC) or to both National Classification and IPC IPC(5): HO4M 11/00 US CL: 379/98,110; 341/22		
II. FIELDS SEARCHED		
Minimum Documentation Searched ⁷		
Classification System	Classification Symbols	
US. CL.	379/90,96-98,100,110; 340/711,706; 341/22; 364/705.05,705.01,709.1	
Documentation Searched other than Minimum Documentation to the Extent that such Documents are Included in the Fields Searched ⁸		
III. DOCUMENTS CONSIDERED TO BE RELEVANT ⁹		
Category ⁹	Citation of Document, ¹¹ with indication, where appropriate, of the relevant passages ¹²	Relevant to Claim No. ¹³
<u>X</u> Y	S.P. HOLMES, "MERLIN TONTO", BRITISH TELECOMMUNICATIONS VOL.5, JANUARY 1987. PP.273-275. (SEE ENTIRE ARTICLE)	1,4 1,2,3,5-7
<u>X</u> Y	C.C. CUTLER, "DISPLAYPHONE: AN INTERACTIVE GRAPHICAL COMMUNICATION EXPERIMENT", CONFERENCE: ELECTRIC TEXT COMMUNICATION, MUNICH, GERMANY, 12-15 JUNE 1978, PP. 323-329. (SEE ENTIRE ARTICLE)	1-6 7
<u>X</u> Y	G.M. DURKIN, "QWERTYPHONE-A LOW-COST INTEGRATED VOICE/DATA TERMINAL; BRITISH TELECOMMUNICATIONS ENGINEERING, VOL. 5, JANUARY 1987, PP. 276-280, (SEE ENTIRE ARTICLE)	1,3-5,7 2,6
Y	US, A, 4,918,723 (IGGULDEN ET AL.) 17 APRIL 1990 SEE FIGS 11,18, COLUMN 10, LINES 35-41	1,2,6
<p>⁹ Special categories of cited documents: ¹⁰</p> <p>"A" document defining the general state of the art which is not considered to be of particular relevance</p> <p>"E" earlier document but published on or after the international filing date</p> <p>"L" document which may throw doubts on priority claim(s) or which is cited to establish the publication date of another citation or other special reason (as specified)</p> <p>"O" document referring to an oral disclosure, use, exhibition or other means</p> <p>"P" document published prior to the international filing date but later than the priority date claimed</p> <p>"T" later document published after the international filing date or priority date and not in conflict with the application but cited to understand the principle or theory underlying the invention</p> <p>"X" document of particular relevance; the claimed invention cannot be considered novel or cannot be considered to involve an inventive step</p> <p>"Y" document of particular relevance; the claimed invention cannot be considered to involve an inventive step when the document is combined with one or more other such documents, such combination being obvious to a person skilled in the art.</p> <p>"&" document member of the same patent family</p>		
IV. CERTIFICATION		
Date of the Actual Completion of the International Search	Date of Mailing of this International Search Report	
30 SEPTEMBER 1991	29 OCT 1991	
International Searching Authority	Signature of Authorized Officer	
ISA/US	 WING FU CHAN	