

(19)
(12)

(KR)
(A)

(51) 。 Int. Cl. ⁷
B65D 47/06

(11)
(43)

2002 - 0023978
2002 03 29

(21) 10 - 2002 - 0000129
(22) 2002 01 02

(71) 37 A 1208

(72) 37 A 1208

:

(54)

(1)

(2)

가 5,332,131 5,392,968
.

(3)

, 가 ,

(4)

가 , ,

1

1

2

3

1 : 2 :

3 : 4 :

5 : 6 :

7 : 8 :

100 :

가

5,332,131

5,392,968

5,332,131

가

가

가

5,392,968

가

가

가

1959

, 가 , 가

1

(1) , (3) (2) ,

(2) (4)

(5) (2) (5) (4) (6) 가 (5) (6)

(6) (100)

(7) (2) (2) 1 (2) (2) (8) (7) , (2)

1 가 (100) (2) (2) (7) , (2) (5) (100) (5)가 (2) (7) (

가 , ,

(57)

1.

, 가 ,

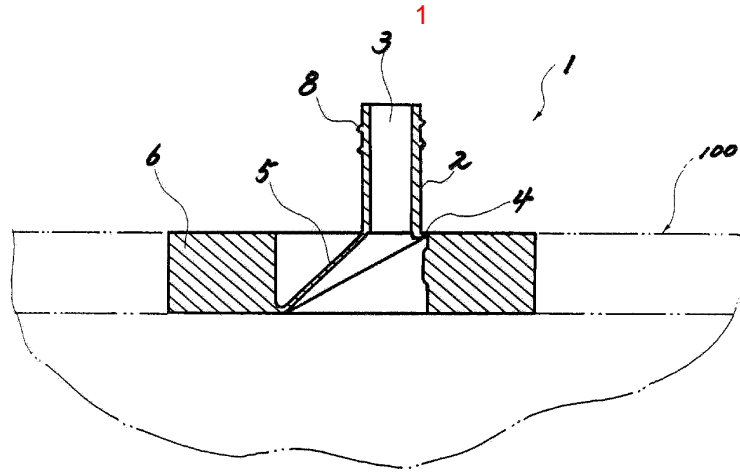

2

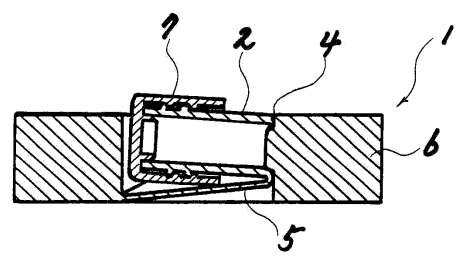

3

